

**SELECTION GUIDE:
ENVIRONMENTAL CORROSION
PROTECTION**

**COMMERCIAL PRODUCTS:
CONDENSER COILS AND COOLING/HEATING COILS**

**ALUMINUM-FIN/COPPER-TUBE COILS
COPPER-FIN/COPPER-TUBE COILS
PRE-COATED ALUMINUM-FIN/COPPER-TUBE COILS
E-COATED ALUMINUM-FIN/COPPER-TUBE COILS
E-COATED COPPER-FIN/COPPER-TUBE COILS**



**Carrier Corporation
Syracuse, New York**

March 2005

TABLE OF CONTENTS

INTRODUCTION	3	Field Applied Coatings	12
WHAT CAUSES CORROSION?	4	E-Coated Material and Chemical Resistance	12
Galvanic Corrosion	4	SELECTION SUMMARY TABLES	14
General Corrosion	5	Protection Option Selection	14
IDENTIFICATION OF POTENTIALLY CORROSIVE ENVIRONMENTS	6	COIL MAINTENANCE AND CLEANING RECOMMENDATIONS	18
Coastal / Marine	6	RELIABILITY TESTING / QUALITY ASSURANCE AT CARRIER	18
Industrial	6	Moist SO ₂ Chamber	18
Combination Marine / Industrial	7	Steam Tests	18
Urban	7	Salt Spray Tests	18
Rural	7	Kure Beach Studies	18
Localized Environment-Corrosivity of the Surroundings	7	Cyclic Corrosion Testing	18
INSTALLATION	8	Prohesion™ Cycle Test Results Comparison	18
CORROSION PROTECTION OPTIONS	9	APPENDIX	20
Condenser Coils	9	E-Coating Chemical Resistance Guide	20
Cooling / Heating Coils Standard Coil Construction	11		

INTRODUCTION

Corrosion is costly. By definition, corrosion is the destruction or deterioration of a metal or alloy through chemical, physical, or electrochemical reaction with the environment. As applied to HVAC equipment, exposure to various elements in the environment can lead to localized and/or general corrosion of heating and cooling coils. Improperly protected coils in corrosive areas can lead to premature performance degradation, unsightly surface conditions and, under the most severe conditions, equipment failure. This can be costly to the customer and result in lost sales caused by the perception of poor product quality. Fortunately, corrosion can be minimized in most cases with proper coil protection.

Commercial equipment that may be susceptible to corrosion includes:

- Rooftop Units
- Air-Cooled Chillers
- Air-Cooled Condensing Units
- Remote Air-Cooled Condensers Make-Up
- Air-Handling Equipment

If units are improperly applied or left unprotected, these units can experience rapid corrosion from exposure to aggressive elements. However, measures can be taken to identify potentially corrosive environments prior to equipment selection. With this information, the best-suited coil protection can be applied to minimize the harmful effects of corrosive elements and ensure long equipment life.

This guide will assist in the selection of appropriate coils and long-term product solutions in potentially corrosive environments by describing:

- What causes corrosion
- How to identify potentially harmful environments
- How to select proper coil protection

With this information, intelligent equipment selection decisions can be made to optimize the level of corrosion protection and maintain the highest level of long-term equipment quality.

WHAT CAUSES CORROSION?

Corrosion takes on many forms. The most common forms of corrosion, as applied to HVAC equipment, are known as galvanic and general corrosion. Each of these corrosion types can lead to equipment failure. As a result, special attention will be given to each of these types of corrosion.

Galvanic Corrosion

When dissimilar metals are in contact in the presence of an electrolyte, a reaction occurs. This reaction is known as galvanic corrosion. There must be a metallic couple between two or more dissimilar metals in the presence of an electrolyte. Without any one of these ingredients, galvanic corrosion will not occur.

Galvanic corrosion of copper tube/aluminum fin heat exchanger coils results in fin degradation, which may ultimately lead to the destruction of the coil. Galvanic corrosion of the unprotected coil begins at the bi-metallic couple between the copper tube and aluminum fin. Because the aluminum is less noble than copper, the aluminum material corrodes. Figure 1 shows a typical standard coil prior to attack from galvanic corrosion.

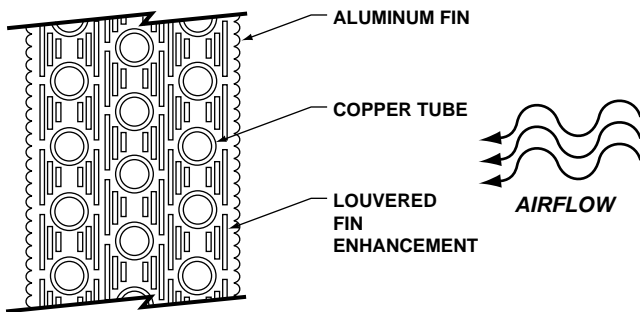

Fig. 1. Standard coil construction.

As galvanic corrosion begins in the standard coil construction, the aluminum fin deteriorates starting at the copper/aluminum interface (Figure 2). Corrosion of the aluminum fin continues until coil performance is adversely affected due to the oxide buildup at the copper tube/aluminum fin interface which creates thermal resistance or severe visual deterioration results. Common visual deterioration

includes aluminum oxide build up around the tube surface and within the fin pack, flaking aluminum fins, fins falling from the coil surface in thin sheets and total removal of the aluminum fin material.

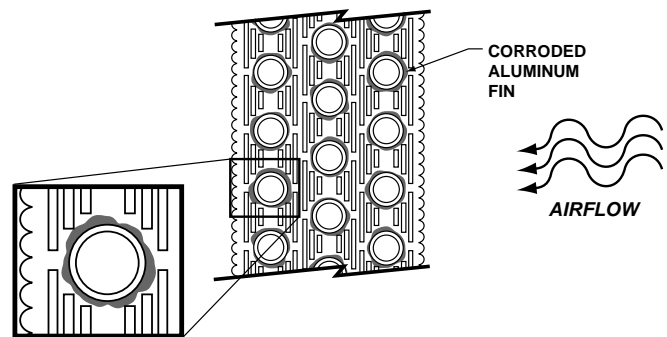

Fig. 2. Galvanic corrosion begins.

Bi-Metallic Construction

The standard coil is manufactured from copper tubes mechanically bonded to aluminum fins. This bond creates a classic bi-metallic couple necessary for galvanic corrosion. An electrolyte in the presence of the copper-tube and aluminum-fin couple is sufficient to initiate a corrosion reaction. However, elimination of the bi-metallic couple can eliminate galvanic corrosion. This can be accomplished with an all copper coil (elimination of the dissimilar metals; one of the necessary factors for galvanic corrosion to occur) or through isolation of the two metals with a protective coating. The protective coating will create a barrier between the metallic couple and the electrolyte to prevent galvanic corrosion (elimination of the electrolyte; one of the necessary conditions for galvanic corrosion). Another method of reducing galvanic corrosion is through insulating the copper from the aluminum through the use of a pre-coated aluminum fin. This breaks up the electrical contact between the copper and the aluminum (elimination of the electrical contact of the dissimilar metals; one of the necessary conditions for galvanic corrosion).

The Electrolyte

Electrolytes are electrically conductive solutions. Common electrolytes may include chloride contaminants from sources such as seawater, road salts, pool cleaners, laundry facilities and household cleaning agents. These electrolytes are typically

sodium or calcium chloride compounds. Other relevant contaminants that may be present include sulfur and nitrogen compounds, from the combustion of coal and fuel oils.

The most common sources of chloride contamination are marine and coastal environments. Sea spray, mist, and fog contain tiny droplets of salt water that can be transported more than several miles by ocean breezes and tidal currents. It is not uncommon to experience salt-water contamination many miles from the coast. As a result, protection from ocean-borne electrolytes in inland areas may be necessary.

General Corrosion

General corrosion is the degradation of metal caused by a reaction with the environment, such as oxidation and chemical attack of the metallic surface. Since general corrosion consumes metal and forms metal oxides, unsightly surface conditions result. For example, copper is susceptible to attack from sulfur containing gases. The result is the formation of a non-protective layer on the material surface. The copper fins will often become very brittle, with the corrosion product being non-adherent to the copper metal surface. Unprotected metal will continue to react with the contaminant and corrode. Under severe, prolonged conditions, the metal continues to corrode until the integrity of the equipment is jeopardized. Unprotected copper in polluted industrial environments can lead to failure of the refrigeration system. Sulfur and nitrogen based electrolytes in combination with chloride environments are often the cause of accelerated corrosion of copper.

Failure of a contaminated copper-fin coil can result from fin degradation and ultimate loss of tube integrity. Furthermore, surface tarnish on copper, such as black, red, green, brown, or yellow deposits, lead to the perception of poor quality.

General corrosion of copper due to a contaminated environment is illustrated as follows. A clean copper tube in an uncontaminated atmosphere maintains system integrity (Figure 3). However, in a contaminated atmosphere, metal oxides begin to form on the copper tube (Figure 4). Prolonged exposure to a contaminated atmosphere results in tube failure (Figure 5).

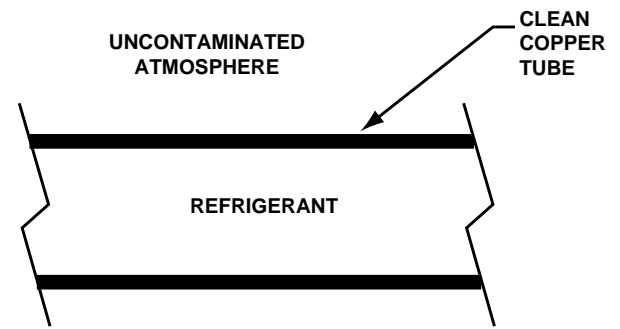

Fig. 3. Clean copper tube.

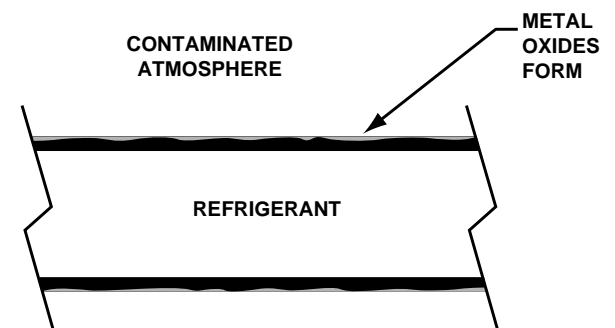

Fig. 4. Oxidation begins.

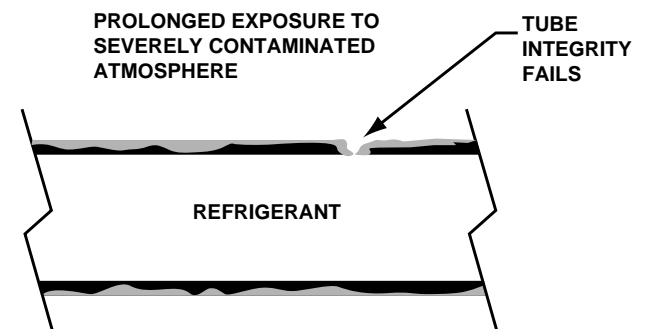

Fig. 5. Tube failure.

IDENTIFICATION OF POTENTIALLY CORROSIVE ENVIRONMENTS

A corrosive environment must be clearly identified and understood before proper coil protection can be selected. In addition to proper coil protection, indoor air quality codes and generally accepted practices must be addressed. Corrosive environments may have a detrimental effect on indoor air quality.

Potentially corrosive outdoor environments include areas adjacent to the seacoast, industrial sites, heavily populated urban areas, some rural locations, or combinations of any of these environments. In air-handling applications, some indoor environments such as swimming pool areas, water treatment facilities, and industrial process areas can produce corrosive atmospheres.

Local environments must also be considered; close proximity to laundry facilities, diesel-burning devices/exhaust piping, sewer vents, traffic, etc. can also lead to premature failure of improperly selected equipment.

Coastal / Marine

Many emerging HVAC markets have a majority of their populations located in coastal areas. This leads to an increased number of air conditioning applications located in corrosive environments.



Coastal or marine environments are characterized by the abundance of sodium chloride (salt) that is carried by sea spray, mist or fog. Most importantly this salt contamination can be carried many miles inland from the coast. Even if the HVAC equipment is a substantial distance from the ocean, corrosion from salt contamination can still occur if the equipment is not properly protected.

Distance from the ocean, prevailing wind direction, relative humidity, wet/dry time and coil temperature will determine the severity of corrosion in the coastal environment. As a result, the following

should be considered when the potential for coastal contamination exists:

- *Is the unit near the ocean?* Visit the proposed installation site. How far away from the ocean is the site? Are the prevailing winds from the ocean? If so, the potential for severe coastal corrosion should be expected and appropriate protection is required.
- *Is there corrosion on exterior structures, other HVAC equipment, or other equipment?* Look around the installation site and surrounding areas. If there is evidence of corrosion, chances are high that corrosive contaminants exist and suitable protection is required.

Industrial

Industrial applications are associated with a host of diverse conditions with the potential to produce various corrosive emissions. Sulfur and nitrogen containing contaminants are most often linked but not limited to industrial and high-density urban environments. Combustion of coal and fuel oils release sulfur oxides (SO_2 , SO_3) and nitrogen oxides (NO_x) into the atmosphere. These gases accumulate in the atmosphere and return to the ground in the form of acid rain or low pH dew.



Not only are industrial emissions potentially corrosive, many industrial dust particles can be laden with harmful metal oxides, chlorides, sulfates, sulfuric acid, carbon, and carbon compounds. These particles, in the presence of oxygen, water, or high humidity environments can be highly corrosive.

Note: These particles/contaminates can be carried for many miles.

Combination Marine/Industrial

Salt-laden seawater mist, combined with the harmful emissions of an industrial environment, poses a severe threat to the life of HVAC equipment. The combined effects of salt mist and industrial emissions will accelerate corrosion. This environment requires superior corrosion resistant properties for air-conditioning components to maintain some level of product quality. Complete encapsulation of the coil surfaces is recommended. E-coated copper-fin coils should be considered.



Urban

Highly populated areas generally have high levels of automobile emissions and increased rates of building heating fuel combustion. Both conditions elevate sulfur oxide (SO_x) and nitrogen oxide (NO_x) concentrations. Corrosion severity in this environment is a function of the pollution levels which in turn depend on several factors including population density for the area, emission control and pollution standards.

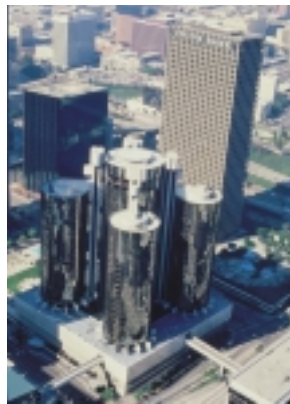

Any HVAC equipment installed near to diesel exhaust, incinerator discharge stacks, fuel burning boiler stacks, areas exposed to fossil fuel combustion emissions, or areas with high automobile emissions should be considered an industrial application. E-coated aluminum-fin coils would be the only acceptable protection in these environments.

Rural

A rural environment typically is unpolluted by exhaust and sulfur containing gasses. Typically a rural environment is sufficiently inland that contamination and high humidity from coastal waters are not present. Protection in these environments is

typically not required beyond the standard aluminum fin/copper tube coil construction.

Sometimes, however, rural environments contain high levels of ammonia and nitrogen contamination from animal excrement, fertilizers, and high concentrations of diesel exhaust. These environments should be handled much like industrial applications with E-coated coil protection.

Localized Environment - Corrosivity of the Surroundings

All of the above environments are subject to "Micro-Climates" which can significantly increase the corrosivity of the environment. Care should be taken to ensure that the localized environment surrounding the HVAC equipment does not contain contaminants that will be detrimental to the coil. For example, if the equipment placement was near a diesel loading area, although the general area where the building may be located may meet the scope of a coastal or marine environment, the localized elements that surround the equipment may actually classify the application as industrial and protection of the coil should be planned accordingly.

Situations to consider when determining the level of corrosivity of the localized environment:

Proximity to:

- Sea water
- Automobile traffic
- Bus traffic
- Truck traffic
- Power plants
- Factories
- Breweries and food processing plants
- Wastewater treatment plants
- Dumps and incineration plants
- Cruise ships and shipping traffic
- Swampy areas (rotting vegetation)

Contributing factors such as:

- Prevailing wind direction
- Acid rain (sources may be hundreds of miles away)
- Humidity levels
- Time of wetness
- Condensation

INSTALLATION

The following situations also contribute to the level of corrosivity of the localized environment:

- Laundry vents or exhausts
- Dryer exhausts
- Laundry rooms
- Exhaust vents



- Diesel tank locations
- Diesel loading areas
- Diesel boiler rooms/exhausts
- Proximity close to cooling towers where carry-over is possible



- Close proximity to sprinkler systems (where over-spray is possible)
- Kitchen exhaust vents
- Sewer exhaust vents
- Areas where insecticide will be utilized
- Areas where fertilizers are applied
- Pools/Hot tubs
- Chemical/cleaner storage areas
- Loading docks
- Bus loading areas



CORROSION PROTECTION OPTIONS

The highest level of product quality can be assured when the right protection is applied. The choices available on Carrier's commercial products offer the right protection for many aggressive environments.

Condenser Coils

Standard Coil Construction

The standard condenser coil has copper-tubes mechanically bonded to aluminum-fins with louvered enhancements. Figure 6 shows a cross-section of a copper tube and several aluminum fins. High thermal efficiency is achieved through direct metallic contact between the tube and fin. Fin louvers improve the fin's heat transfer capabilities. As a result, maximum thermal performance is achieved with this high efficiency coil design provided there is no corrosion.

The standard coil generally provides the highest performance for non-corrosive environments. (e.g., non-polluted Rural Environments). Application of this coil in any environment containing corrosive constituents is not recommended due to the likelihood of visible deterioration resulting from corrosion.

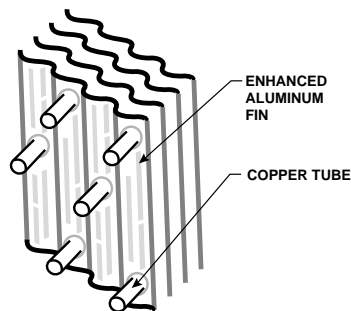

Fig. 6. Standard coil construction.

Pre-Coated Aluminum-Fin Coils

Pre-coated aluminum-fin coils have a durable epoxy coating applied to the fin. This design offers protection in mildly corrosive coastal environments, but is not recommended in severe industrial or severe coastal environments.

Aluminum fin stock is coated with a baked-on epoxy coating prior to the fin stamping process (Figure 7). Coating of the fin material prior to the fin stamping process is known as "pre-coating." The pre-coated fin material is then stamped to form a wavy fin pattern for optimum thermal performance. The wavy design can be recognized by the vertical corrugation on the fin face. Vertical corrugations increase the fin's effective surface area and further enhance heat transfer properties.

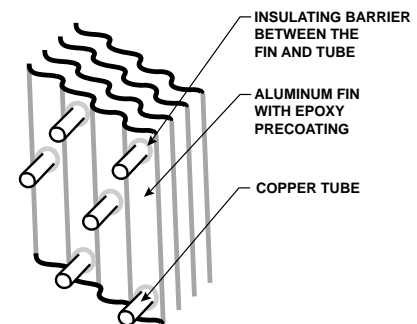

Fig. 7. Pre-coated coil assembly.

A thin layer of inert epoxy precoating material insulates the dissimilar metals of the coil from one another. As a result, the electrical connection between the copper and aluminum is broken, thus preventing galvanic corrosion. In mild coastal environments precoated coils are an economical alternative to E-coated coils and offer substantial corrosion protection beyond the standard uncoated coil.

Copper-Fin Coils

Copper-fin coils eliminate the bi-metallic bond found on standard fin coils (Figure 8). A copper wavy fin pattern, void of louvered enhancements, is mechanically bonded to the standard copper tube. All copper tube sheets are also provided to enhance the natural resistance of all copper construction. A protective Mylar strip installed between the coil assembly and sheet metal coil support pan further protects the coil from galvanic corrosion.

Copper-fin coils are priced higher than aluminum precoated fin coils, since material costs for copper are greater than aluminum. However, coastal corrosion durability in an unpolluted marine environment can be substantially improved over the standard or precoated coil construction, since the bi-metallic construction is not present.

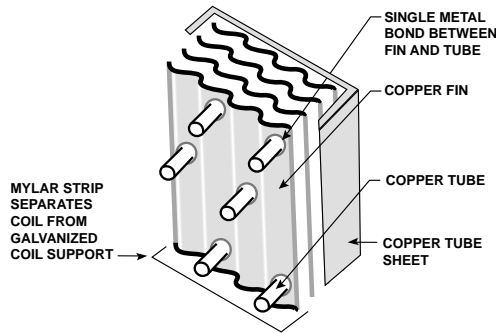

Fig. 8. Copper-fin coil assembly.

Copper-fin coils provide increased corrosion resistance in coastal environments where pollution sources are not present. Copper is generally resistant to unpolluted coastal environments, since a natural protective film is formed to passivate the copper surfaces. Furthermore, a mono-metal bond exists between the tube and the fin. However, uncoated copper coils are not suitable for polluted coastal applications or industrial applications, since many pollutants attack copper. The use of uncoated copper in these applications is not appropriate and must be avoided to ensure long coil life. E-coated aluminum-fin coils should be considered for such applications.

E-Coated Aluminum-Fin Coils

E-coated coils provide superior protection against many corrosive atmospheres with the exception of formic acid and nitric acid environments. For a complete listing of the chemicals to that the E-coat is resistant, please refer to the appendix.

E-coated aluminum-fin coils have an extremely durable and flexible epoxy coating uniformly applied over all coil surfaces for complete encapsulation from exposure to the contaminated environment. A consistent coating is achieved through a precisely controlled electrocoating process that bonds a thin impermeable epoxy coating on the specially prepared coil surfaces.

Electrocoating is a multi-step process that ensures ultra clean coils are properly coated, cured and protected from environmental attack (Figure 9). This process includes complete immersion degreasing to remove contamination and ensure all surfaces are

ultra clean. The water bath rinses residual dust and contamination away in preparation for the E-coating process. The fundamental principle of electrocoating is that the materials with opposite electrical charges attract each other. An electrocoating system applies a DC charge to the coil immersed in a bath of oppositely charged epoxy molecules. The molecules are drawn to the metal, forming an even, continuous film over the entire surface. At a certain point, the coating film insulates the metal, stopping the attraction, and preventing further coating deposition (self-limiting nature of the coating process).

The final rinse bath removes and recovers residual coating material to ensure a smooth coating and minimizes process waste. A precisely controlled oven bake cures the coating uniformly to ensure consistent adhesion on all coil surfaces. Finally, a UV protective topcoat is applied to shield the finish from ultraviolet degradation and to ensure coating durability and long life.

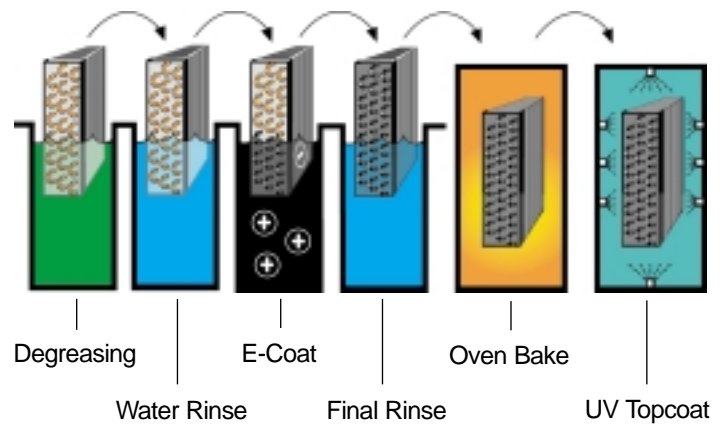

Fig. 9. E-coat process.

This creates a smooth, consistent and flexible coating that penetrates deep into all coil cavities and covers the entire coil assembly including the fin edges (Figure 10). The process in conjunction with the coating material results in a less brittle, more resilient and more durable coating without bridging between adjacent fins than previous phenolic coatings. E-coated coils provide superior protection in the most severe environments.

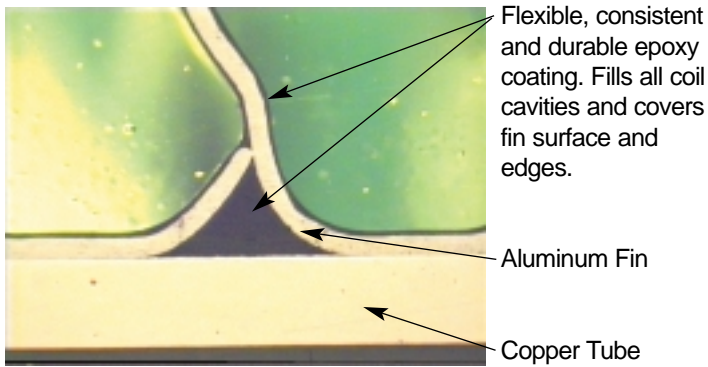

Fig. 10. Magnification of E-coated aluminum-fin copper-tube coil.

E-Coated Copper-Fin Coils

E-coated copper-fin coils have the same durable and flexible epoxy coating uniformly applied over all coil surfaces as the E-coated aluminum-fin coils (Figure 11). However, these coils combine the natural resistance of all copper construction with complete encapsulation from the E-coat process. E-coated copper-fin coils should be specified for environments with harsh coastal conditions.

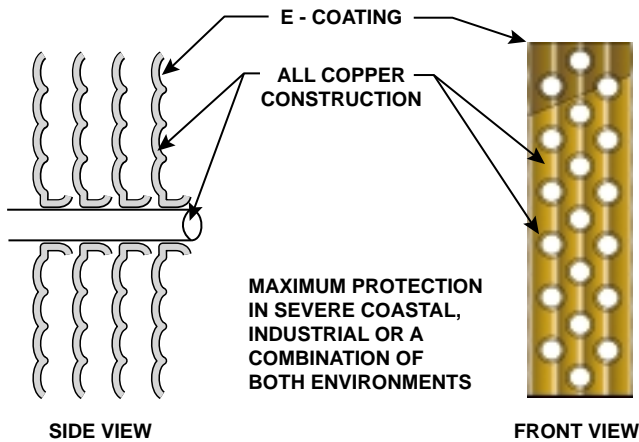

Fig. 11. E-coated copper/copper coil.

Cooling/Heating Coils Standard Coil Construction

The standard cooling/heating coil (water, steam, or Direct Expansion) has copper-tubes mechanically bonded to non-lanced aluminum-fins with a wavy pattern embossed on the fin face. The fin pack is assembled with galvanized steel tubesheets and coil case. This assembly has classic galvanic corrosion components with multi-metal bonds between the fin-and-tube and tube-and-tubesheet.

In cooling applications, condensate accumulates on the coil surfaces when dehumidification occurs. Wet coil surfaces resulting from condensation in the presence of a contaminated airstream will lead to galvanic corrosion if not properly protected.

Potentially corrosive airstreams may not be suitable for building occupants. If a contaminated airstream can lead to corrosion, special consideration with respect to indoor air quality and potentially harmful side effects to building occupants is recommended.

Copper-Fin Copper-Tube Coils

Much like the all-copper condenser coil, all-copper cooling/heating coils eliminate the bi-metallic bond found on standard coils. A copper fin with wavy pattern is mechanically bonded to the standard copper tube to ensure a single-metal assembly. Most air-handling equipment is available with stainless steel tubesheets and coil cases to improve the corrosion durability of the entire coil assembly. As a result, the potential for corrosion is reduced since bi-metallic couples can be reduced within the coil assembly.

E-Coated Coils

E-coated coils have the same E-coating as the condenser coils (see Condenser Coils section on page 9). All E-coated coils have a durable and flexible epoxy coating uniformly applied over all coil surfaces, including tubesheets and coil cases. The coating provides a barrier between the coil surfaces and the corrosive effects of the atmosphere to prevent contamination of the coil surfaces. Since cooling/heating coils are not exposed to the potentially harmful ultraviolet rays from the sun, the UV top-coat is unnecessary.

In considering E-coated coils, it is important to also consider the effects of moisture carryover. Moisture carryover occurs when accumulated condensation is blown from the coil surface during cooling coil applications. The extent of carryover is a function of airstream velocity across the coil, fin spacing, fin geometry and material of construction. When E-coating is applied to a cooling coil, carryover will occur at lower coil face velocities. Recommendations shown in Table A should be considered when selecting chilled water or DX coils to ensure moisture carryover will be prevented.

Table A
Maximum Recommended Face Velocity (FPM)*

Fin Spacing (FPI)	Aluminum-Fin	Copper-Fin	E-coated Coil
8	650	500	500
11	650	425	425
14	575	375	375

FPI - Fins per Inch FPM - Feet per Minute

*External fouling on cooling coils will adversely affect the maximum recommended face velocities. Data based on clean coils with proper filtration and periodic cleaning of coil surfaces.

Field Applied Coatings

Most field applied sprayed-on coatings generally do not provide sufficient protection in corrosive environments. Possible reasons for poor performance:

- Coil cleanliness is crucial for proper adhesion. Adequate field cleaning techniques are generally overlooked.
- Field application cannot ensure continuous coating of coil surfaces on multiple row coils. It is difficult to ensure uniform coating quality throughout the depth of the fin pack.
- Interior coil surfaces remain untreated when sprayed-on from unit exterior (often spray applicators cannot reach deep into the coil assemblies, leaving inconsistent coating).

- Inconsistent coating thickness can minimize or negate coating protection. Recommended coating thickness cannot be ensured with field application on multiple row coils. Film thickness measurements are generally overlooked.
- The coil must be void of corrosion prior to field application of the coating. Encapsulation of existing corrosion makes the coating ineffective by leading to continued deterioration and coating delamination.

E-Coated Material and Chemical Resistance

Chemical resistance of the E-coating material is described in the appendix, "E-coating Chemical Resistance Guide." Application of an E-coated coil should only be considered when the contaminant is listed in the Appendix guide. If the E-coating is NOT resistant to the contaminant listed or if the contaminant is not listed in the appendix, application in this environment is not recommended. Contact your Carrier representative for further guidance.

Common industrial contaminants which are resisted by the E-coated coils are shown in Table B.

**Table B
Industrial Contaminants**

Contaminant	Chemical Symbols	Type of Industry/ Application	Source of Contaminant	Potential Color of Corrosion (on copper)*
Sulfur Oxides	SO ₂ SO ₃	Pulp, Paper & Lumber Plants Incineration Facilities Fuel Burning Power Generation Diesel/Gasoline Engine Operation	Process Emissions Products of Combustion	Black Blue
Nitrogen Oxides	NO _x	Pulp, Paper & Lumber Plants Incineration Facilities Fuel Burning Power Generation Diesel/Gasoline Engine Operation	Process Emissions Products of Combustion	Black Blue
Chlorine & Chlorides	Cl ₂ Cl _x	Cleaning Agent Processing Water Treatment Facilities Salt Mining/Processing Swimming Pool Agents	Process Emissions Water Disinfection Process By-Products	Brownish Yellow (Non-hydrated) Green (hydrated)
Ammonia & Ammonia Salts	NH ₃ NH ₄	Chemical Industries Fertilizer Manufacturers Waste Water Treatment Facilities Agriculture	Process Emissions Process By-Products Waste Digestion Animal Waste & Fertilizers	Black
Hydrogen Sulfide	H ₂ S	Waste Water Treatment Facilities	Sludge Processing	Black

* Discoloration is an indication of potential problems. However, identification of contamination sources based on color may be misleading.

**SELECTION SUMMARY TABLES
(TABLES C-H)**

Protection Option Selection

Clearly identify the operating environment for the intended installation. Determine the severity of each environmental factor associated with the installation site. Choose the protection option based on the most severe environmental factor anticipated for the given site. As an example: the site is on the coastline and the condenser coil is facing the ocean, but there is not noticeable corrosion on other equipment. An E-coated Aluminum-Fin Copper-Tube option is recommended. Always choose the option for the most severe environmental factor.

**Table C
Coastal Environment Protection Option**

Coil Option	Severity of Environmental Factors				
	Low $\xrightarrow{\hspace{10em}}$ Severe				
	Distance from Coast				
	Inland				Coastline
	Direction of Prevailing Winds				
From Coast to Unit			From Unit to Coast		
Corrosion Present on Other Equipment					
None Present		Noticeable Corrosion			
Standard: Aluminum-Fin / Copper-Tube	X	NR	NR	NR	NR
Copper-Fin / Copper-Tube	ACC	ACC	X	NR	NR
Pre-Coated Aluminum-Fin / Copper-Tube	ACC	X	NR	NR	NR
E-Coated Aluminum-Fin / Copper-Tube	ACC	ACC	ACC	ACC	X
E-Coated Copper-Fin / Copper-Tube	ACC	ACC	ACC	ACC	X

ACC - Acceptable application with corrosion protection in excess of required level

X - Recommended Option

NR - Not Recommended

Note: Environments immediately adjacent to diesel exhaust, incinerator discharge stacks, fuel burning boiler stacks, or areas exposed to fossil fuel combustion emissions should be considered a Combined Coastal/Industrial application. Recommendations presented for Industrial and Combined Coastal/Industrial Environments should be followed.

Table D
Industrial Environment Protection Option

Coil Option	Severity of Environmental Factors				
	Low \longrightarrow Severe				
	Contaminant Concentration*				
	0 ppm		100 ppm		
Coil Option	Corrosion Present on Other Equipment				
	None Present		Noticeable Corrosion		
Standard: Aluminum-Fin / Copper-Tube	X	NR	NR	NR	NR
Copper-Fin / Copper-Tube	NR	NR	NR	NR	NR
Pre-Coated Aluminum-Fin / Copper-Tube	ACC	X	NR	NR	NR
E-Coated Aluminum-Fin / Copper-Tube	ACC	ACC	X	X	X
E-Coated Copper-Fin / Copper-Tube	NR	NR	NR	NR	NR

ACC - Acceptable application with corrosion protection in excess of required level
X - Recommended Option
NR - Not Recommended
* "E-Coating Chemical Resistance Guide", appendix.

Table E
Combined Coastal/Industrial Environment Protection Option

Coil Option	Severity of Environmental Factors				
	Low \longrightarrow Severe				
	Distance from Coast				
	Inland		Coastline		
	Direction of Prevailing Winds				
Coil Option	From Coast to Unit		From Unit to Coast		
	Corrosion Present on Other Equipment				
Coil Option	None Present		Noticeable Corrosion		
	Standard: Aluminum-Fin / Copper-Tube	X	NR	NR	NR
Copper-Fin / Copper-Tube	NR	NR	NR	NR	NR
Pre-Coated Aluminum-Fin / Copper-Tube	ACC	X	NR	NR	NR
E-Coated Aluminum-Fin / Copper-Tube	ACC	ACC	X	X	X
E-Coated Copper-Fin / Copper-Tube	NR	NR	NR	NR	NR

ACC - Acceptable application with corrosion protection in excess of required level
X - Recommended Option
NR - Not Recommended
* "E-Coating Chemical Resistance Guide", appendix.

Table F
Urban Environment Protection Option

Coil Option	Severity of Environmental Factors				
	Low $\xrightarrow{\hspace{10em}}$ Severe				
	Pollution Levels/Population Density				
	Low				High
	Corrosion Present on Other Equipment				
	None Present				Noticeable Corrosion
Standard: Aluminum-Fin / Copper-Tube	X	NR	NR	NR	NR
Copper-Fin / Copper-Tube	NR	NR	NR	NR	NR
Pre-Coated Aluminum-Fin / Copper-Tube	ACC	ACC	X	NR	NR
E-Coated Aluminum-Fin / Copper-Tube	ACC	ACC	ACC	X	X
E-Coated Copper-Fin / Copper-Tube	NR	NR	NR	NR	NR

ACC - Acceptable application with corrosion protection in excess of required level

X - Recommended Option

NR - Not Recommended

Note: Environments immediately adjacent to diesel exhaust, incinerator discharge stacks, fuel burning boiler stacks, or areas exposed to fossil fuel combustion emissions should be considered a Combined Coastal/Industrial application. Recommendations presented for Industrial and Combined Coastal/Industrial Environments should be followed.

Table G
Advantages/Disadvantages of Protection Options

Coil Option	Advantages	Disadvantages
Standard Coil	<ul style="list-style-type: none"> • High Thermal Efficiency • Lowest Cost • Light Weight 	<ul style="list-style-type: none"> • Limited Corrosion Protection capability in corrosive applications
Pre-Coated Coil	<ul style="list-style-type: none"> • Low Cost • Galvanic Decoupling 	<ul style="list-style-type: none"> • Reduced Thermal Efficiency • Limited Protection Capabilities • Inappropriate in severely corrosive environments
Copper/Copper	<ul style="list-style-type: none"> • Corrosion Durability in unpolluted marine environment • Effective Thermal Performance • Mono-metal Construction 	<ul style="list-style-type: none"> • Highest Cost • Greatest Weight • Not effective in some marine/industrial environments • Lower velocity limits require coil to receive optimum airflow in cooling coil application • Unexpected Corrosion due to local pollutants
E-Coating	<ul style="list-style-type: none"> • Flexible, Consistent, Durable • Superior Corrosion Protection • Complete Coil Encapsulation • Creates Barrier between all coil surfaces and corrosive environments 	<ul style="list-style-type: none"> • Higher Cost • Greater Weight

Table H
Comparison of Protection Options with Standard Aluminum-Fin Copper-Tube Coil

Coil Option	Cost	Availability	Corrosion Protection	Weight	Thermal Performance
E-Coated Copper Fin	----	-	++++	--	-
E-coated Aluminum Fin	---	-	++++	-	-
Pre-coated Aluminum Fin	-	=	++	=	-
Copper Fin	--	=	+	--	=

- + Superior to Standard Coil
- = Equal to Standard Coil
- Less Favorable to Standard Coil

Note: More than one + indicates factor is significantly better than standard coil; more than one - indicates factor is significantly less favorable than standard coil.

COIL MAINTENANCE AND CLEANING RECOMMENDATIONS

Routine cleaning of coil surfaces is essential to maintain proper operation of the unit. Elimination of contamination and removal of harmful residues will greatly increase the life of the coil and extend the life of the unit.

RELIABILITY TESTING/QUALITY ASSURANCE AT CARRIER

As part of Carrier's commitment to continuous product improvement and quality assurance, many tests can be performed to determine the level of corrosion protection for specific applications and environments.

Moist SO₂ Chamber

Moist SO₂ testing is typically accomplished in what is referred to as a Kesternich Chamber. The purpose of this cyclical testing is to simulate industrial atmospheres by introducing a known volume of SO₂ gas and exposing material to this while simultaneously controlling the humidity at a high level for 8 hours. This is followed by an ambient condition dry cycle of 16 hours.

Steam Tests

The steam test was developed at Carrier to rapidly evaluate the quality of various coatings. This test exposes coated metal panels to steam generated by a distilled water bath and heaters for various lengths of time. Generally the exposure period is 48 hours, however, additional testing has been performed over other lengths of time to determine the total time to blister (a measure of the adhesive properties of a coating to a substrate).

Salt Spray Tests

Typically, salt spray testing is done according to the ASTM Specification - B117. This cycle exposes material to continuous salt fog commonly between 500 and 2000 hours in duration. This is strictly a comparative test as it does not correlate well to actual atmospheric exposure.

Kure Beach Studies

Coils and equipment are exposed to a coastal environment at a facility run by the LaQue Center for Corrosion Testing in Kure Beach, NC. The atmospheric conditions are monitored at this site where exposures have been done over the years at 80-ft or 800-ft distances from the mean tide line. The testing performed here allows Carrier to determine actual performance of corrosion protection methods in a coastal environment. The results obtained from testing at the beach are used to develop accelerated laboratory methods to simulate coastal environments and to test methods for preventing corrosion.

Traditional salt spray testing has been performed according to the neutral salt spray test ASTM Specification - B117 which uses a continuous 5% salt fog at 35 degrees C. This has been the accepted corrosion test method for more than 80 years, but good correlation between the test results and corrosion seen in actual atmospheric exposures has seldom been found. New test methods involving cyclical exposures are being developed which can be better correlated with actual atmospheric exposure results.

Cyclic Corrosion Testing

Carrier utilizes a cyclic Corrosion Tester for enhanced testing capabilities at the LaQue Center. The Q-fog Model CCT600 is used to obtain more realistic corrosion performance results than can be obtained from traditional steady-state exposures.

Carrier's use of the cyclic Corrosion Tester allows accelerated testing methods to be developed more quickly. The chamber is able to run various programmed cycles such as the Prohesion™ cycle, GM exposures (GM9540PLB), Japanese automotive cycles, Japanese acid rain cycles, and many other cyclic tests deemed necessary to provide meaningful corrosion data.

Prohesion™ Cycle Test Results Comparison

The corrosion performance of a baseline bare coil, a pre-coated coil, three (3) post-coated coils and an E-coated coil have been evaluated through

Prohesion testing. This test subjects the coil to cyclical exposure to highly corrosive solutions and regulated drying time to simulate severely corrosive environmental conditions.

After 1000 hours of cyclical exposure, the corrosion performances of the coils were evaluated by visual examination and through heat transfer measurement.

The heat transfer performance factor G^* is used to evaluate the thermal performance of the coils. G^* shows a change in implied performance for a coil compared to a baseline coil's new implied performance. The higher G^* value, the better the thermal performance.

Figure 12 shows the thermal performance results after exposure for 1000 hours. It can be seen that E-coated coils have the best performance for this type exposure. The other coil coatings fall well short of the E-coat performance.

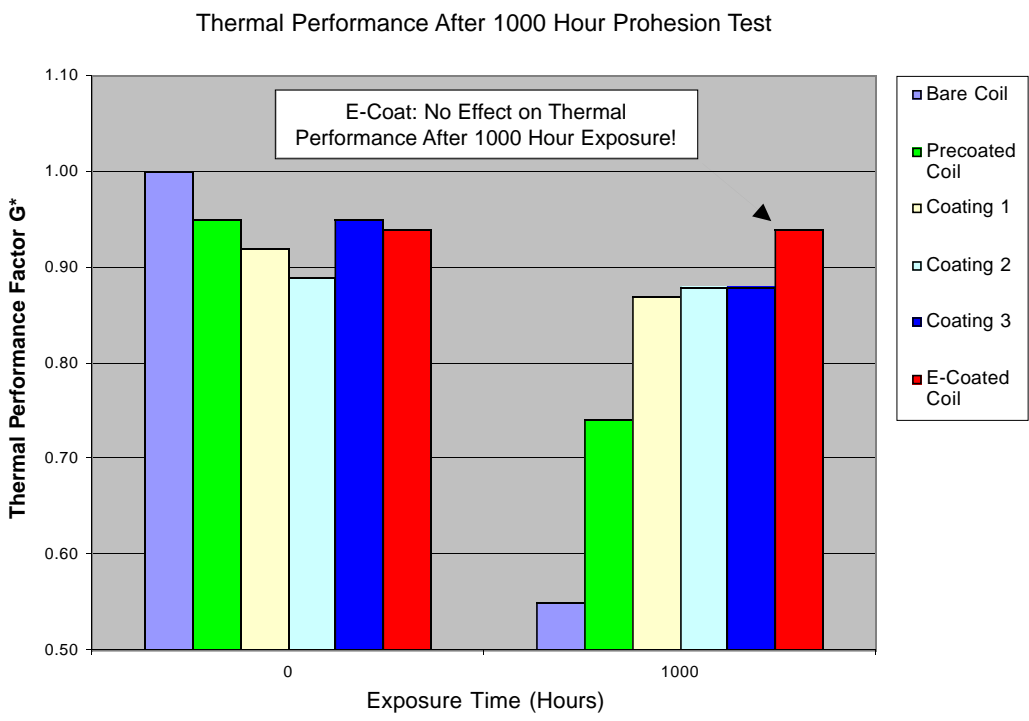

Fig. 12. Prohesion test results.

APPENDIX

E-Coating Chemical Resistance Guide

The coating materials used for E-Coat will withstand exposure to many corrosive atmospheres with the exception of formic acid and nitric acid. The E-Coat material is resistant to fumes from the chemicals listed below. However, Carrier does not recommend direct coil immersion service for any of these chemicals. The chemical resistance guidelines were determined by a 24-hour spot test exposure of the chemical listed at ambient temperature conditions. Resistance was determined for these chemicals at the concentrations identified.

Since resistance is dependent upon the application, environment, type of protection, and other factors, your Carrier Representative should be consulted for recommendations.

E-Coat is resistant to the following fumes:

Acetone	Fructose	Ozone
Acetic Acid 99%	Gasoline	Perchloric Acid
Acetates (ALL)	Glucose	Phenol 85%
Amines (ALL)	Glycol	Phosgene
Ammonia	Glycol Lither	Phenolphthlaein
Ammonium Hydroxide	Hydrochloric Acid 37%	Phosphoric Acid
Amino Acids	Hydrofluoric Acid 30%	Potassium Chloride
Benzene	Hydrogen Peroxide 5%	Potassium Hydroxide
Borax	Hydrogen Sulfide	Propionic Acid
Boric Acid	Hydrazine	Propyl Alcohol
Butyl Alcohol	Hydroxylamine	Propylene Glycol
Butyl Cellosolve	Iodine	Salicylic Acid
Butric Acid	Isobutyl Alcohol	Salt Water
Calcium Chloride	Isopropyl Alcohol	Sodium Bisulfite
Calcium Ilypochloric	Kerosene	Sodium Chloride
Carbon Tetrachloride	Lactic Acid	Sodium Hypochlorite 5%
Cetyl Alcohol	Lactose	Sodium Hydroxide 10%
Chlorides (ALL)	Lauryl Alcohol	Sodium Hydroxide 25%
Chlorine Gas	Magnesium Chloride	Sodium Sulfate
Chloroform	Magnesium Sulfate	Sorbitol
Chromic Acid 25%	Maleic Acid	Stearic Acid
Citric Acid	Menthol	Sucrose
Cresol	Menthanol	Sulfuric Acid 25-85%
Diesel Fuel	Methylene Chloride	Sulfates (ALL)
Diethanolamine	Methyl Ethyl Ketone	Sulfides (ALL)
Ethyl Acetate	Methyl Isobutyl Ketone	Sulfites (ALL)
Ethyl Alcohol	Mustard Gas	Starch
Ethyl Ether	Naphthol	Toluene
Fatty Acid	Nitric Acid 25%	Triethanolamine
Fluorine Gas	Olale Acid	Urea
Formaldehyde 27%	Oxalic Acid	Vinegar
		Xylene

E-Coat is NOT resistant to the following fumes:

Formic Acid • Nitric Acid

Note: All data, statements, and recommendations are based on research conducted by the E-Coat manufacturer and are believed to be accurate. However, no guarantee of accuracy can be made and Carrier Corporation assumes no liability as a result.

