



## Product Data

# 07DA, DB 07EA, EB, ED Condensing Units

3 to 40 Nominal Tons



## 06D, 06E Compressors

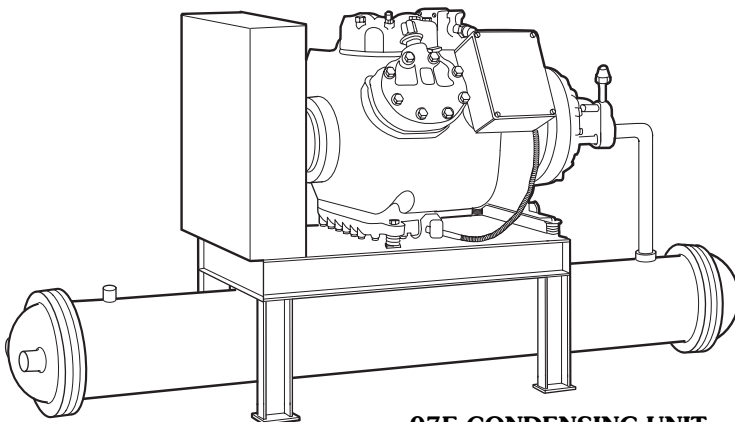

**07E CONDENSING UNIT**

An excellent choice for your built-up system — Carrier 07 Series condensing units — built for the engineer who writes a spec that provides the most for the money. Compare the features you prefer in a condensing unit with those offered by the 07 Series, and you'll see the advantages in choosing Carrier.

## Features/Benefits

### Wide application range

Model 07 condensing units are designed for a wide range of commercial and industrial air conditioning and refrigeration applications. They give the engineer great design flexibility, since an 07 unit can be combined with a wide variety of coils or chillers to provide a cooling system that closely matches actual load requirements. This results in an energy-saving system that operates efficiently at maximum load conditions.

There are many standard units to choose from, in addition to special orders available by calling your Carlyle representative. Thus, you are assured of the economy, capacity, and distribution voltage your application requires.

### Factory assembled

Rugged and versatile 07 Series units are factory assembled, ready to be piped into your system. Matched up with the condenser are a serviceable compressor, compact control center, and all interconnecting piping and wiring. The units are designed for use with most refrigerants.

# Features/Benefits (cont)



## The benefits are many

- fully assembled units
- capacities to 40 tons
- system design flexibility
- commercial and industrial application
- for use with most refrigerants
- special-order combinations available on request

## Accurate system design

**Broad range of sizes** allows selection of evaporator coil or chiller to form a well-balanced system. Capacity will closely match the system load requirements, and provide efficient, energy-saving, economical operation at maximum load conditions.

**A unit for all load conditions** is offered, from refrigeration to air conditioning duty. Units have shell-and-tube condensers. All are compactly designed to take minimum floor space. The 07 Series units are built and tested to comply with ASME (American Society of Mechanical Engineers) Code for unfired pressure vessels, and ANSI/ASHRAE 15 (American National Standards Institute/American Society of Heating, Refrigeration and Air Conditioning Engineers) latest revision safety standard.

## Economical operation

**Capacity control valves** are provided in all 07 Series units, except 07DA203 models, giving a built-in system for conserving power and water and assuring accurate control. When only partial load operation is needed, capacity control valves automatically step down compressor capacity. Refrigeration output can be reduced to about one third of full load in direct response to suction pressure changes. When system load is reduced, power and water usage are also reduced. Suction cutoff unloading further reduces energy usage during unloaded operation. Valve body shuts off passage from suction manifold, preventing charge from unnecessarily being pulled into the cylinder. This results in an EER (Energy Efficiency Ratio) improvement of as much as 39.5% at 33% load.

## Built-in reliability

**Condenser** includes a pressure relief device which protects the system against overpressure.

**Compressor** has motor overtemperature protection. On 07E models, manually reset 3-phase circuit breakers protect against power irregularities. High- and low-pressure switches are standard. Oil-pressure switch is standard on 07D and 07E models. An automatically reversible oil pump with automatic pressure regulator keeps

bearings properly lubricated. Crankcase heater keeps oil warm and prevents dilution of oil by refrigerant during shutdown. Time Guard circuit prevents short cycling by compressor. After shutdown, the timing device delays compressor start-up for approximately 5 minutes. This reduces wear and extends compressor life. Compressor motor is sealed against dirt and moisture and is cooled by suction gas. It eliminates drive shaft alignment and shaft seal problems.

## Noise and vibration control

**Muffler** in discharge line minimizes sound level.

**Compressor** is mounted on spring isolators to minimize transfer of vibration from compressor to base structure.

## Low-cost maintenance

**Condenser heads** are removable for tube maintenance or replacement. An oil level sight glass allows easy inspection of compressor oil level. Liquid line shut-off valve allows evaporator or chiller to be serviced without loss of refrigerant. The condenser serves as a reservoir for holding liquid refrigerant when the system is not in operation, keeping downtime to a minimum since refrigerant need not be replaced for start-up.

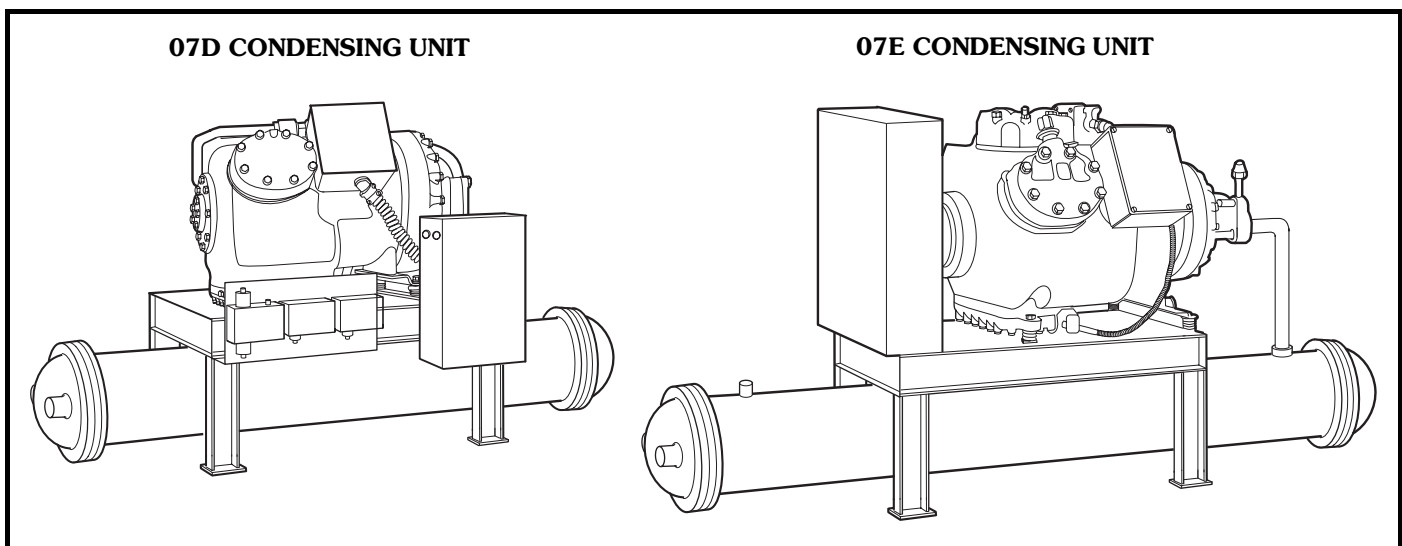

# Table of contents



	Page
Features/Benefits . . . . .	1,2
Model Number Nomenclature . . . . .	3,4
Physical Data . . . . .	5
Base Unit Dimensions. . . . .	6,7
Field-Installed Accessories . . . . .	8
Selection Procedure . . . . .	8
Performance Data . . . . .	8-17
Electrical Data . . . . .	18,19
Typical Wiring Schematics . . . . .	20-22
Typical Piping and Wiring . . . . .	23
Application Data . . . . .	24
Guide Specifications . . . . .	25,26

## Model number nomenclature

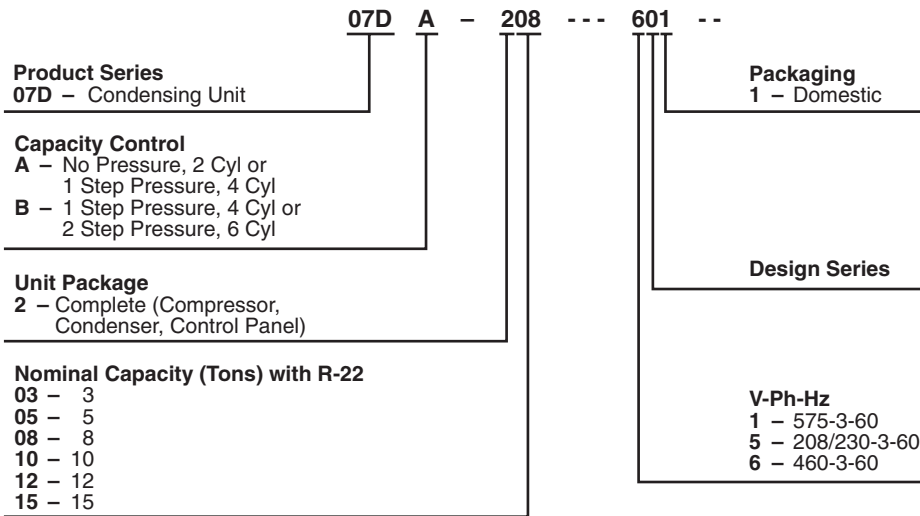

# Model number nomenclature (cont)

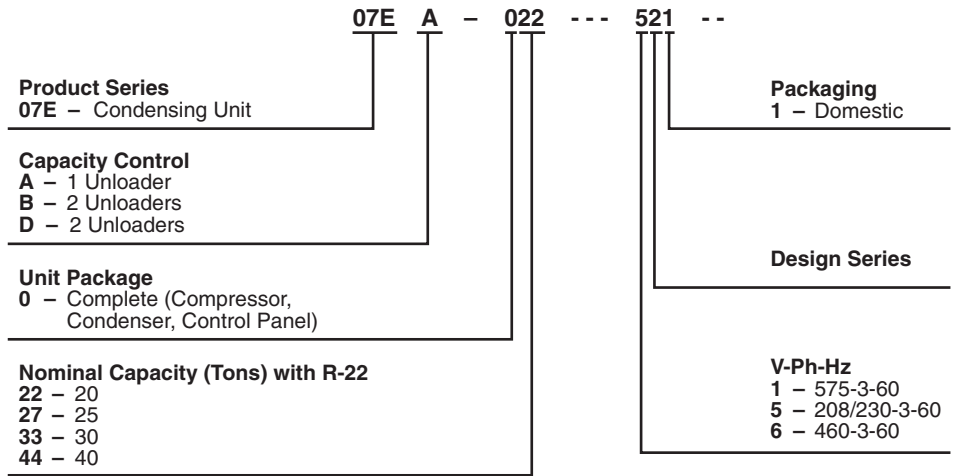

# Physical data



UNIT 07D		A203	B205	A208	B210	B212	B215
OPERATING WEIGHT (lb)		270	395	420	545	595	620
REFRIGERANT		R-134a, R-22, R-507/404A					
COMPRESSOR — 06D*		M808	M313	A818	A825	A328	A537
Cylinders		2	4	4	6	6	6
Bore (in.)		2	2	2	2	2	2
Stroke (in.)		1 <sup>1/4</sup>	1	1 <sup>7/16</sup>	1 <sup>1/4</sup>	1 <sup>15/32</sup>	1 <sup>15/16</sup>
Displacement (cfm at 1750 rpm)		8	13	18.3	23.9	28	37.1
Oil Charge (pt)		3	4.5	5.5	8	8	8
High Side Maximum Pressure		450 PSIG					
Low Side Maximum Pressure		245 PSIG					
CONDENSER (Shell and Tube)† Part Number		P701-0605CX	P701-0607CX	P701-0610CX	P701-0615CX	P701-0620CX	P701-0625AX
Refrigerant Storage Capacity (lb)	R-134a	17.20	15.90	24.40	31.60	27.40	39.80
		2.86	3.16	5.00	7.55	8.47	9.18
Min Refrigerant Operating Charge (lb)	R-22	17.00	15.70	24.10	31.20	27.10	39.30
		2.80	3.10	4.90	7.40	8.30	9.00
	R-507/404A	14.70	13.60	20.90	27.10	23.50	34.10
		2.80	3.10	4.90	7.40	8.30	9.00
REFRIGERANT CONNECTION (in. ODF)							
Inlet		1 <sup>5/8</sup>	1 <sup>5/8</sup>	1 <sup>5/8</sup>	1 <sup>5/8</sup>	1 <sup>5/8</sup>	1 <sup>5/8</sup>
Outlet		1 <sup>1/8</sup>	1 <sup>1/8</sup>	1 <sup>1/8</sup>	1 <sup>1/8</sup>	1 <sup>1/8</sup>	1 <sup>1/8</sup>
WATER CONNECTION (in. FPT)							
Inlet/Outlet		1	1	1 <sup>1/4</sup>	1 <sup>1/4</sup>	1 <sup>1/4</sup>	2

### LEGEND

FPT — Female Pipe Thread  
ODF — Outside Diameter, Female

\*Compressor listed is the standard compressor for R-22, air conditioning duty. An 06DR compressor is standard equipment for low temperature (R-507/404A) or medium temperature (R-134a) applications. Factory substitutions may be made. Contact Carrier Sales Representative.

†The condenser listed is for R-22, air conditioning duty and may change based on the application. Maximum condenser operating pressure: 350 psi refrigerant side, 300 psi water side ("CX" models); 350 psi refrigerant side, 150 psi water side ("AX" models).

NOTE: The 07DB210 with the 06DA825 compressor replaces the 07DB210 with the 06DA824 once the compressor inventory is depleted.

UNIT 07E		A022	B027	B033	D044
OPERATING WEIGHT (lb)		1090	1200	1250	1410
REFRIGERANT		R-134a, R-22, R-507/404A			
COMPRESSOR — 06E*		A250	A265	A275	A299
Cylinders		4	6	6	6
Bore (in.)		2 <sup>11/16</sup>	2 <sup>11/16</sup>	2 <sup>11/16</sup>	2 <sup>11/16</sup>
Stroke (in.)		2 <sup>3/16</sup>	2	2 <sup>3/16</sup>	2 <sup>7/8</sup>
Displacement (cfm at 1750 rpm)		50	68	75	99
Oil Charge (pt)		14	19	19	19
High Side Maximum Pressure		450 PSIG			
Low Side Maximum Pressure		245 PSIG			
CONDENSER (Shell and Tube)† Part Number		P701-0840AX	P701-0850AX	P701-0850AX	P701-1065AX
Refrigerant Storage Capacity (lb)	R-134a	71.3	85.90	85.90	112.70
		15.4	18.67	18.67	23.77
Min Refrigerant Operating Charge (lb)	R-22	70.4	84.80	84.80	111.20
		15.1	18.30	18.30	23.30
	R-507/404A	61.1	73.60	73.60	96.50
		15.1	18.30	18.30	23.30
REFRIGERANT CONNECTION (in. ODF)					
Inlet		2 <sup>1/8</sup>	2 <sup>1/8</sup>	2 <sup>1/8</sup>	2 <sup>5/8</sup>
Outlet		1 <sup>3/8</sup>	1 <sup>3/8</sup>	1 <sup>3/8</sup>	1 <sup>5/8</sup>
WATER CONNECTION (in. FPT)					
Inlet/Outlet		2 <sup>1/2</sup>	2 <sup>1/2</sup>	2 <sup>1/2</sup>	3

### LEGEND

FPT — Female Pipe Thread  
ODF — Outside Diameter, Female

\*Compressor listed is the standard compressor for R-22, air conditioning duty. An 06ER compressor is standard equipment for low temperature (R-507/404A) applications. For medium temperature (R-134a) applications, an 06EM compressor is standard. Factory substitutions may be made. Contact Carrier Sales Representative.

†The condenser listed is for R-22, air conditioning duty and may change based on the application. Maximum condenser operating pressure: 350 psi refrigerant side, 150 psi water side.

# Base unit dimensions



## 07D CONDENSING UNIT

DIMENSIONS (in.)

UNIT 07D	WIDTH A
A203	30
B205	30
A208	39 <sup>9</sup> / <sub>16</sub>
B210	51 <sup>9</sup> / <sub>16</sub>
B212	51 <sup>9</sup> / <sub>16</sub>
B215	63 <sup>13</sup> / <sub>16</sub>

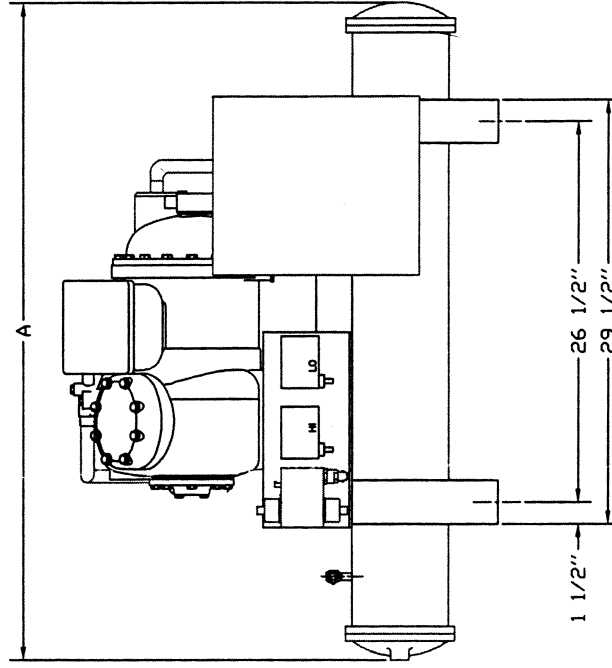
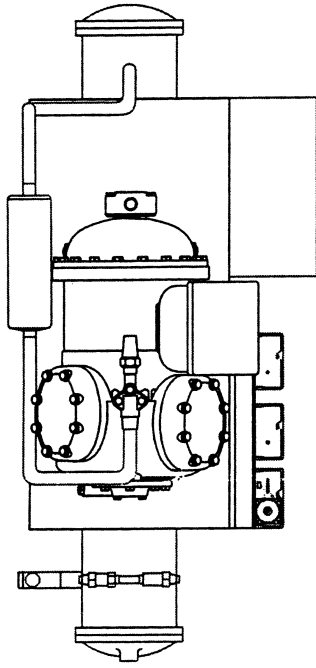
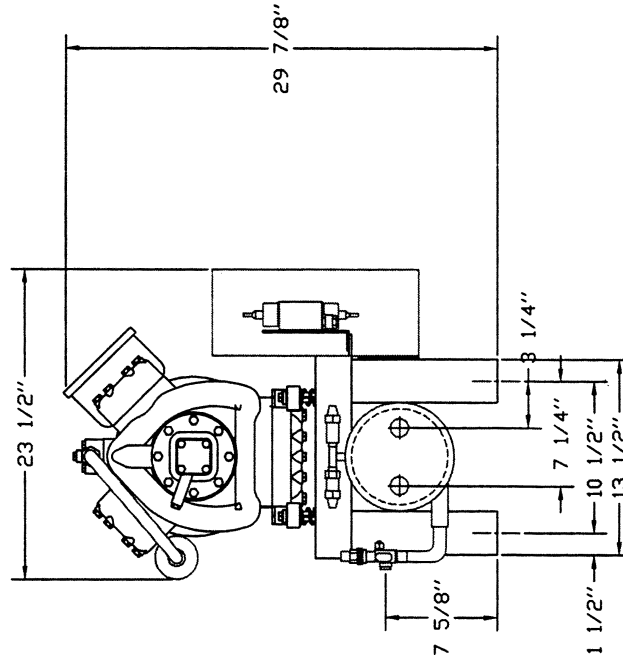

NOTE: Water connections for 07DB215 unit only.

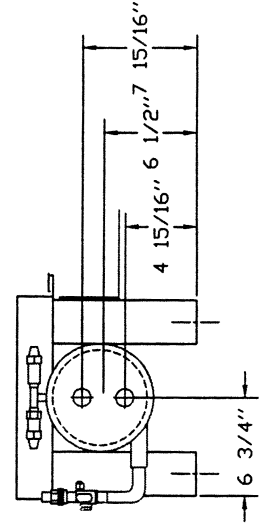

NOTES:

1. For standard service practices, such as troubleshooting and refrigerant charging, allow a minimum 2'-6" clearance around the unit.
2. Recommended service space for condenser tube removal is one condenser length at either end.
3. For compressor removal, allow a minimum 3' wide access aisle to and from the unit.
4. Local codes or jurisdiction may prevail for unit clearances.

**07E CONDENSING UNIT**

**DIMENSIONS (in.)**

UNIT 07E	VOLTS	A	B	C	D	E	F	G	H	I
A022	208/230	66	49 <sup>3</sup> / <sub>4</sub>	2 <sup>3</sup> / <sub>4</sub>	34	27 <sup>1</sup> / <sub>2</sub>	1	21	5 <sup>9</sup> / <sub>16</sub>	9 <sup>5</sup> / <sub>16</sub>
	460, 575	66	43 <sup>3</sup> / <sub>4</sub>	2 <sup>3</sup> / <sub>4</sub>	34	26	1	21	5 <sup>9</sup> / <sub>16</sub>	9 <sup>5</sup> / <sub>16</sub>
B027	208/230	78	49 <sup>3</sup> / <sub>4</sub>	2 <sup>3</sup> / <sub>4</sub>	34	27 <sup>1</sup> / <sub>2</sub>	1	21	5 <sup>9</sup> / <sub>16</sub>	9 <sup>5</sup> / <sub>16</sub>
	460, 575	78	43 <sup>3</sup> / <sub>4</sub>	2 <sup>3</sup> / <sub>4</sub>	34	26	1	21	5 <sup>9</sup> / <sub>16</sub>	9 <sup>5</sup> / <sub>16</sub>
B033	208/230	78	49 <sup>3</sup> / <sub>4</sub>	2 <sup>3</sup> / <sub>4</sub>	34	27 <sup>1</sup> / <sub>2</sub>	1	21	5 <sup>9</sup> / <sub>16</sub>	9 <sup>5</sup> / <sub>16</sub>
	460, 575	78	43 <sup>3</sup> / <sub>4</sub>	2 <sup>3</sup> / <sub>4</sub>	34	26	1	21	5 <sup>9</sup> / <sub>16</sub>	9 <sup>5</sup> / <sub>16</sub>
D044	208/230	69 <sup>1</sup> / <sub>2</sub>	49 <sup>3</sup> / <sub>4</sub>	2 <sup>3</sup> / <sub>4</sub>	34	27 <sup>1</sup> / <sub>2</sub>	1	21	4 <sup>1</sup> / <sub>8</sub>	8 <sup>5</sup> / <sub>8</sub>
	460, 575	69 <sup>1</sup> / <sub>2</sub>	49 <sup>3</sup> / <sub>4</sub>	2 <sup>3</sup> / <sub>4</sub>	34	27 <sup>1</sup> / <sub>2</sub>	1	21	4 <sup>1</sup> / <sub>8</sub>	8 <sup>5</sup> / <sub>8</sub>

**NOTES:**

1. For standard service practices, such as troubleshooting and refrigerant charging, allow a minimum 2'-6" clearance around the unit.
2. Recommended service space for condenser tube removal is one condenser length at either end.
3. For compressor removal, allow a minimum 3' wide access aisle to and from the unit.
4. Local codes or jurisdiction may prevail for unit clearances.

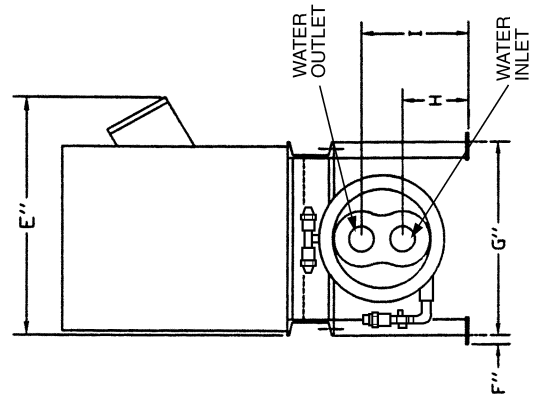
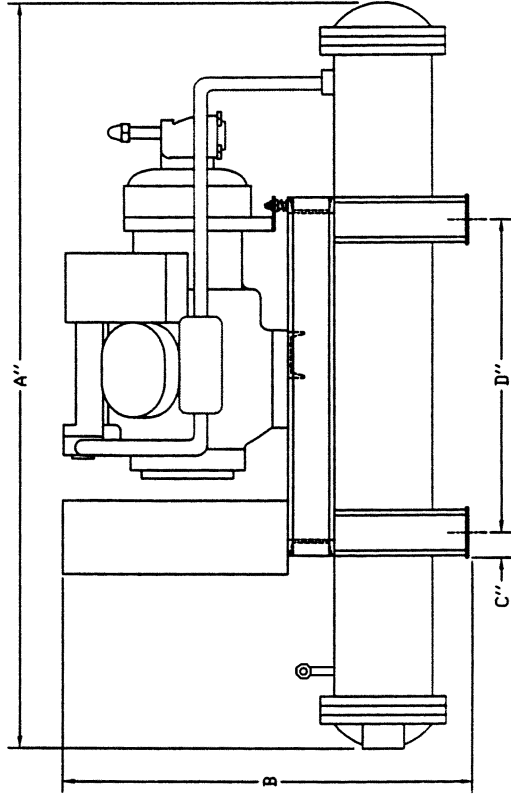
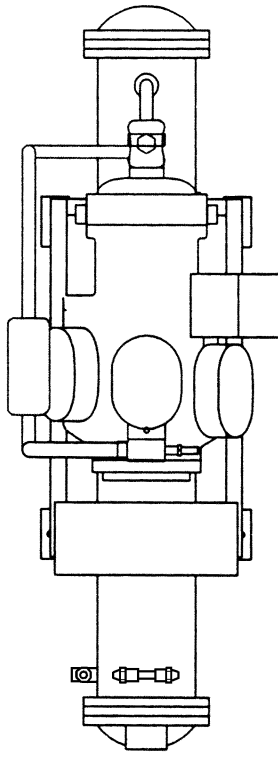

# Field-installed accessories



## Sizes 3 through 40 tons

**Control circuit transformer** eliminates need for external control power source.

## Sizes 10 through 40 tons

**Electric solenoid unloader** converts unloader operation from suction pressure operation to electrical operation.

## Sizes 20 through 40 tons

**Gage panel** located on control center for easy, at-a-glance monitoring of suction, discharge, and oil pressure.

# Selection procedure (with example)

### I Determine refrigerant, load, saturated suction temperature, and entering condenser water temperature.

Given

Refrigerant . . . . .	R-22
Cooling Load . . . . .	30 Tons
Saturated Suction Temperature . . . . .	40 F
Entering Condenser Water Temperature . . . . .	85 F
Greatest Temperature Difference (GTD) . . . . .	20 F

### III Determine gpm and water pressure drop through condenser.

Enter Condenser Capacity and Flow Rates table at P701-0850AX Condenser (for 07EB033 condensing unit) with a 20 GTD (greatest temperature difference). The GTD is the difference between the entering water temperature and saturated condensing temperature. The THR (total heat of rejection) required is 38.12 tons or 457,440 Btuh. The required gpm for the THR falls between 50 and 70 gpm. Through interpolation the required gpm is 62.25 and the pressure drop (PD) is 1.59 psi.

**NOTE: The capacities listed in the Condenser Capacity and Flow Rate tables are based on 105 SCT. When operating at SCT between 90 F and 120 F, the change in condenser capacity is minimal. All data points available in hard copy format for R-22 are not available for R-134a and R-507/404A. Interpolation may be necessary. Contact Carrier Sales Representative for more information.**

### II Determine condensing unit selection saturated condensing temperature, compressor power input, total heat rejection. Use direct interpolation when job requirements fall between values shown.

Enter the 07E Condensing Unit Capacities table for R-22 at 40 F saturated suction temperature. An 07EB033 unit with 30.56 tons capacity is closest to meeting the 30-ton cooling load requirement. Saturated condensing temperature is 105 F, compressor power input is 26.5 kW and the total heat rejection is 38.12 tons.

# Performance data

## GENERAL NOTES FOR 07D,E CAPACITIES TABLES

1. Condensing unit capacities are based on liquid subcooling of 2 F with 1750 rpm compressor speed.
2. Condenser water quantities are based on a .0005 fouling factor.
3. Refrigerant temperatures shown are saturated temperatures corresponding to pressure indicated at compressor. Actual gas temperature is higher because of superheat.
4. Capacities are based on actual suction gas temperatures to the compressor: 65 F for R-134a and R-507/404A. This assumes superheat is obtained from liquid suction interchanger or in evaporator. Capacity corrections for other than rated suction gas temperatures may be obtained from Rating Basis and Capacity Multipliers table. R-22 suction gas superheat (15 F) normally

occurs because of expansion valve operation and line losses. Therefore, R-22 ratings can be used without adjustment.

5. Condenser leaving water temperature (t<sub>lw</sub>) is calculated as follows (temperature in degrees F):

$$t_{lw} = \text{Entering water temp (t}_{ew}) + \frac{\text{total heat rejection (tons)} \times 24}{\text{condensing water flow (gpm)}}$$

$$t_{lw} = t_{ew} + \frac{\text{THR (tons)} \times 24}{\text{gpm}}$$

# Performance data (cont)



## STANDARD RATINGS — AIR CONDITIONING DUTY

UNIT 07	REFRIG	SST (F)	SCT (F)	CAP.	kW	THR	GPM	LWT	PD
DA203	22	40	105	3.35	2.63	4.10	6.3	100.9	0.98
DB205				5.30	4.19	6.49	11.0	99.4	2.00
DA208				7.64	5.99	9.35	15.0	100.1	1.40
DB210				9.88	7.70	12.07	17.3	101.9	2.00
DB212				11.78	9.22	14.41	20.5	102.1	1.90
DB215				16.02	13.35	19.83	34.6	98.9	1.20
EA022				21.38	17.60	26.40	42.0	100.3	0.70
EB027				28.18	23.40	34.85	54.6	100.5	1.20
EB033				30.56	26.50	38.12	62.1	99.9	1.50
ED044				40.10	37.31	50.73	89.5	98.8	1.30

### LEGEND

- CAP.** — Capacity (tons)
- EWT** — Entering Water Temperature
- GPM** — Gallons Per Minute
- kW** — Compressor Power Input
- LWT** — Leaving Water Temperature (F)
- PD** — Pressure Drop (psi)\*
- RGT** — Return Gas Temperature
- SCT** — Saturated Condensing Temperature (F)
- SST** — Saturated Suction Temperature (F)
- THR** — Total Heat Rejection (tons)

\*To convert psi to feet multiply by 2.31.

NOTE: Unit ratings are at the following conditions — SST 40 F, RGT 65 F, EWT 85 F, SCT 105 F, 2 F subcooling.

## 07D CONDENSING UNIT CAPACITIES (Tons)\*

R-22

SST	SCT	07DA203			07DB205			07DA208			07DB210			07DB212			07DB215		
		Cap.	kW	THR	Cap.	kW	THR	Cap.	kW	THR	Cap.	kW	THR	Cap.	kW	THR	Cap.	kW	THR
0	90	1.39	1.90	1.93	2.12	3.02	2.98	3.15	4.16	4.34	3.97	5.27	5.47	4.93	6.55	6.80	6.85	9.17	9.46
	100	1.26	1.98	1.82	1.89	3.11	2.78	2.84	4.32	4.07	3.58	5.54	5.16	4.52	6.90	6.48	6.32	9.67	9.07
	105	1.19	2.01	1.76	1.78	3.14	2.68	2.68	4.37	3.93	3.39	5.65	5.00	4.32	7.06	6.33	6.06	9.89	8.88
	110	1.12	2.04	1.71	1.67	3.16	2.57	2.53	4.42	3.79	3.20	5.75	4.84	4.12	7.21	6.17	5.80	10.11	8.68
	120	0.99	2.10	1.59	1.45	3.20	2.36	2.22	4.45	3.49	2.83	5.90	4.51	3.73	7.47	5.86	5.30	10.48	8.29
10	90	1.84	2.05	2.42	2.84	3.29	3.78	4.17	4.57	5.47	5.29	5.76	6.93	6.44	7.10	8.47	8.87	10.03	11.73
	100	1.68	2.19	2.31	2.58	3.46	3.56	3.81	4.85	5.19	4.81	6.15	6.56	5.93	7.58	8.09	8.21	10.74	11.28
	105	1.60	2.25	2.24	2.44	3.53	3.45	3.63	4.96	5.04	4.58	6.32	6.38	5.68	7.80	7.91	7.90	11.06	11.05
	110	1.53	2.30	2.18	2.31	3.59	3.33	3.45	5.07	4.89	4.35	6.49	6.19	5.44	8.02	7.72	7.58	11.37	10.82
	120	1.37	2.39	2.05	2.05	3.68	3.10	3.09	5.22	4.57	3.90	6.77	5.83	4.96	8.40	7.35	6.96	11.93	10.36
20	90	2.37	2.16	2.98	3.71	3.47	4.69	5.38	4.86	6.77	6.89	6.15	8.64	8.29	7.50	10.43	11.33	10.69	14.38
	100	2.19	2.35	2.86	3.39	3.73	4.46	4.96	5.26	6.46	6.31	6.67	8.21	7.66	8.14	9.98	10.52	11.65	13.84
	105	2.10	2.44	2.79	3.24	3.84	4.33	4.75	5.44	6.30	6.03	6.91	8.00	7.35	8.44	9.76	10.13	12.09	13.57
	110	2.00	2.52	2.72	3.08	3.95	4.21	4.54	5.61	6.14	5.75	7.14	7.78	7.05	8.73	9.54	9.73	12.52	13.30
	120	1.82	2.66	2.58	2.78	4.13	3.95	4.12	5.90	5.80	5.20	7.56	7.35	6.46	9.27	9.10	8.97	13.29	12.76
30	90	2.99	2.20	3.62	4.73	3.56	5.75	6.82	5.01	8.25	8.82	6.41	10.65	10.51	7.72	12.71	14.28	11.05	17.43
	100	2.78	2.45	3.48	4.37	3.91	5.48	6.33	5.55	7.91	8.12	7.07	10.14	9.74	8.55	12.18	13.30	12.30	16.80
	105	2.68	2.56	3.40	4.18	4.07	5.34	6.09	5.79	7.74	7.78	7.38	9.88	9.37	8.93	11.92	12.82	12.87	16.49
	110	2.57	2.67	3.33	4.00	4.23	5.21	5.84	6.03	7.56	7.44	7.68	9.63	9.00	9.31	11.65	12.34	13.44	16.17
	120	2.36	2.87	3.18	3.64	4.50	4.92	5.35	6.46	7.19	6.78	8.24	9.13	8.27	10.01	11.13	11.40	14.49	15.53
40	90	3.72	2.18	4.34	5.94	3.52	6.94	8.49	4.99	9.91	11.11	6.50	12.97	13.16	7.71	15.36	17.78	11.02	20.93
	100	3.48	2.48	4.18	5.51	3.98	6.64	7.93	5.67	9.54	10.28	7.31	12.37	12.24	8.74	14.73	16.60	12.61	20.20
	105	3.35	2.63	4.10	5.30	4.19	6.49	7.64	5.99	9.35	9.88	7.70	12.07	11.78	9.22	14.41	16.02	13.35	19.83
	110	3.23	2.77	4.02	5.09	4.39	6.34	7.36	6.30	9.16	9.47	8.08	11.77	11.33	9.70	14.10	15.44	14.08	19.46
	120	2.99	3.03	3.85	4.66	4.77	6.02	6.79	6.88	8.75	8.67	8.79	11.18	10.45	10.60	13.48	14.31	15.43	18.71
50	90	4.50	2.10	5.10	7.23	3.30	8.17	10.29	4.80	11.66	13.62	6.40	15.45	16.06	7.40	18.17	21.60	10.50	24.59
	100	4.24	2.40	4.92	6.77	3.90	7.89	9.69	5.60	11.28	12.69	7.40	14.80	15.02	8.70	17.50	20.28	12.50	23.85
	105	4.11	2.60	4.85	6.54	4.15	7.73	9.38	6.00	11.09	12.24	7.85	14.48	14.52	9.30	17.17	19.64	13.40	23.46
	110	3.97	2.80	4.77	6.31	4.40	7.57	9.08	6.40	10.90	11.79	8.30	14.16	14.02	9.90	16.84	19.00	14.30	23.07
	120	3.71	3.10	4.59	5.85	4.90	7.25	8.46	7.10	10.48	10.91	9.20	13.53	13.03	11.00	16.17	17.74	16.00	22.30

### LEGEND

- Cap.** — Capacity (tons)
- kW** — Compressor Power Input
- SCT** — Saturated Condensing Temperature (F)
- SST** — Saturated Suction Temperature (F)
- THR** — Total Heat Rejection (tons)

\*Refer to capacity notes, page 8.

NOTE: To ensure proper motor cooling, it is required that all 6-cylinder compressors operating with R-22 at 20 F SST or below have one of the 2 unloaders disconnected. Cylinder head fan required at SST of 0° F and below for R-22 for all compressors.

# Performance data (cont)



## 07D CONDENSING UNIT CAPACITIES (Tons)\* (cont) R-134a

SST	SCT	07DB205			07DA208			07DA210			07DB212			07DB215		
		Cap.	kW	THR	Cap.	kW	THR	Cap.	kW	THR	Cap.	kW	THR	Cap.	kW	THR
0	90	1.27	1.78	1.78	2.09	2.70	2.86	2.61	3.29	3.55	3.22	4.22	4.42	4.44	5.76	6.08
	100	1.12	1.83	1.64	1.91	2.83	2.72	2.33	3.40	3.30	2.96	4.42	4.21	4.11	6.08	5.84
	105	1.05	1.84	1.57	1.82	2.88	2.64	2.19	3.44	3.17	2.82	4.50	4.10	3.94	6.22	5.71
	110	0.98	1.84	1.50	1.74	2.93	2.57	2.05	3.48	3.04	2.69	4.58	3.99	3.76	6.35	5.57
	120	0.84	1.83	1.36	1.57	3.01	2.43	1.78	3.50	2.78	2.42	4.69	3.75	3.41	6.57	5.28
10	90	1.76	2.02	2.34	2.79	3.03	3.65	3.58	3.78	4.66	4.26	4.69	5.59	5.79	6.33	7.59
	100	1.58	2.12	2.18	2.56	3.22	3.48	3.23	3.98	4.37	3.94	4.99	5.36	5.40	6.76	7.33
	105	1.49	2.16	2.10	2.45	3.30	3.39	3.06	4.06	4.22	3.78	5.12	5.23	5.20	6.97	7.19
	110	1.40	2.19	2.02	2.34	3.38	3.30	2.89	4.13	4.07	3.61	5.25	5.11	5.00	7.17	7.04
	120	1.23	2.23	1.86	2.12	3.52	3.13	2.56	4.25	3.77	3.29	5.47	4.85	4.59	7.52	6.74
20	90	2.37	2.22	3.00	3.66	3.30	4.60	4.78	4.25	5.99	5.50	5.10	6.96	7.41	6.85	9.36
	100	2.14	2.38	2.82	3.37	3.57	4.38	4.35	4.53	5.64	5.12	5.51	6.69	6.94	7.40	9.05
	105	2.03	2.45	2.73	3.23	3.69	4.28	4.14	4.65	5.47	4.93	5.70	6.55	6.71	7.66	8.89
	110	1.93	2.51	2.64	3.09	3.81	4.17	3.93	4.77	5.29	4.73	5.88	6.41	6.48	7.92	8.73
	120	1.71	2.62	2.46	2.81	4.02	3.96	3.52	4.98	4.94	4.34	6.21	6.11	5.98	8.41	8.38
30	90	3.10	2.36	3.78	4.73	3.48	5.72	6.24	4.69	7.57	7.00	5.41	8.54	9.32	7.31	11.40
	100	2.83	2.59	3.57	4.36	3.85	5.46	5.72	5.05	7.16	6.54	5.94	8.23	8.77	7.96	11.04
	105	2.70	2.69	3.47	4.18	4.02	5.33	5.46	5.22	6.95	6.31	6.19	8.07	8.49	8.29	10.85
	110	2.57	2.79	3.36	4.01	4.19	5.20	5.21	5.38	6.74	6.07	6.43	7.91	8.21	8.61	10.66
	120	2.31	2.96	3.15	3.66	4.48	4.94	4.70	5.68	6.32	5.60	6.88	7.56	7.63	9.23	10.26
40	90	4.00	2.42	4.69	6.03	3.54	7.04	8.00	5.08	9.45	8.78	5.62	10.38	11.60	7.69	13.79
	100	3.67	2.72	4.45	5.58	4.03	6.72	7.37	5.53	8.94	8.23	6.27	10.02	10.94	8.46	13.35
	105	3.51	2.86	4.32	5.35	4.26	6.57	7.06	5.74	8.69	7.95	6.58	9.82	10.60	8.84	13.12
	110	3.35	3.00	4.20	5.13	4.48	6.41	6.75	5.95	8.44	7.67	6.89	9.63	10.26	9.22	12.89
	120	3.03	3.25	3.96	4.70	4.88	6.09	6.13	6.35	7.94	7.10	7.47	9.23	9.57	9.97	12.41
50	90	5.07	2.44	5.77	7.61	3.60	8.64	10.11	5.42	11.66	10.89	5.67	12.51	14.28	7.99	16.56
	100	4.68	2.77	5.47	7.05	4.06	8.20	9.35	5.96	11.05	10.23	6.46	12.07	13.49	8.87	16.02
	105	4.48	2.95	5.32	6.77	4.35	8.01	8.97	6.22	10.75	9.89	6.85	11.84	13.09	9.32	15.74
	110	4.29	3.13	5.18	6.50	4.64	7.82	8.60	6.48	10.44	9.55	7.23	11.62	12.68	9.76	15.46
	120	3.90	3.46	4.89	5.96	5.17	7.44	7.85	6.98	9.84	8.87	7.95	11.14	11.85	10.64	14.88

LEGEND

\*Refer to capacity notes, page 8.

- Cap. — Capacity (tons)
- kW — Compressor Power Input
- SCT — Saturated Condensing Temperature (F)
- SST — Saturated Suction Temperature (F)
- THR — Total Heat Rejection (tons)



**07D CONDENSING UNIT CAPACITIES (Tons)\* (cont)**  
**R-507/404A**

SST	SCT	07DB205			07DA208			07DB210			07DB212			07DB215		
		Cap.	kW	THR	Cap.	kW	THR	Cap.	kW	THR	Cap.	kW	THR	Cap.	kW	THR
-30	90	0.99	2.11	1.59	1.81	3.68	2.86	2.13	4.34	3.37	2.78	5.52	4.35	3.79	7.37	5.89
	100	0.86	2.09	1.45	1.64	3.78	2.72	1.89	4.36	3.13	2.50	5.61	4.10	3.42	7.59	5.59
	105	0.79	2.07	1.38	1.55	3.81	2.64	1.77	4.35	3.01	2.35	5.61	3.95	3.24	7.68	5.43
	110	0.73	2.05	1.31	1.46	3.84	2.56	1.64	4.34	2.88	2.20	5.61	3.80	3.06	7.77	5.28
	120	0.61	1.99	1.18	1.28	3.86	2.38	1.39	4.25	2.60	1.89	5.51	3.46	2.71	7.92	4.97
-20	90	1.43	2.59	2.17	2.43	4.27	3.65	2.96	5.14	4.43	3.75	6.42	5.58	5.01	8.60	7.46
	100	1.26	2.62	2.00	2.22	4.44	3.49	2.67	5.27	4.17	3.43	6.67	5.33	4.54	8.92	7.08
	105	1.17	2.63	1.92	2.12	4.51	3.40	2.51	5.31	4.03	3.26	6.76	5.18	4.30	9.06	6.88
	110	1.09	2.63	1.84	2.01	4.58	3.32	2.36	5.34	3.88	3.08	6.84	5.03	4.07	9.20	6.69
	120	0.93	2.60	1.67	1.79	4.68	3.12	2.05	5.36	3.58	2.72	6.93	4.70	3.61	9.44	6.30
-10	90	1.99	3.07	2.86	3.17	4.82	4.54	3.91	5.93	5.60	4.89	7.20	6.94	6.52	9.85	9.33
	100	1.76	3.16	2.67	2.92	5.07	4.37	3.60	6.15	5.35	4.51	7.62	6.68	5.91	10.30	8.85
	105	1.66	3.19	2.57	2.79	5.18	4.27	3.41	6.24	5.19	4.31	7.80	6.53	5.61	10.50	8.61
	110	1.55	3.22	2.46	2.66	5.29	4.17	3.23	6.33	5.03	4.11	7.97	6.38	5.31	10.70	8.36
	120	1.33	3.24	2.26	2.39	5.48	3.95	2.85	6.46	4.69	3.68	8.24	6.03	4.72	11.10	7.89
0	90	2.68	3.53	3.69	4.04	5.33	5.56	5.14	6.68	7.05	6.23	7.83	8.46	8.37	11.10	11.54
	100	2.40	3.68	3.45	3.74	5.66	5.36	4.71	7.00	6.70	5.78	8.43	8.18	7.60	11.70	10.94
	105	2.26	3.74	3.32	3.59	5.82	5.25	4.48	7.15	6.52	5.54	8.70	8.02	7.22	11.95	10.63
	110	2.12	3.80	3.20	3.43	5.97	5.13	4.26	7.29	6.34	5.30	8.96	7.86	6.84	12.20	10.32
	120	1.84	3.89	2.95	3.10	6.25	4.88	3.80	7.53	5.94	4.79	9.42	7.48	6.09	12.70	9.70
10	90	3.53	4.00	4.67	5.07	5.80	6.72	6.71	7.37	8.81	7.77	8.30	10.14	10.59	12.20	14.07
	100	3.17	4.20	4.37	4.71	6.20	6.47	6.12	7.84	8.35	7.24	9.10	9.83	9.64	13.00	13.34
	105	2.99	4.30	4.22	4.52	6.40	6.34	5.82	8.05	8.11	6.95	9.45	9.65	9.17	13.35	12.97
	110	2.82	4.40	4.07	4.33	6.60	6.21	5.52	8.26	7.88	6.67	9.80	9.46	8.69	13.70	12.60
	120	2.48	4.50	3.76	3.94	7.00	5.94	4.92	8.60	7.37	6.07	10.40	9.04	7.76	14.40	11.86
20	90	4.54	4.30	5.76	6.25	6.20	8.02	8.50	7.85	10.74	9.55	8.50	11.97	13.24	13.20	17.00
	100	4.10	4.70	5.44	5.82	6.70	7.73	7.77	8.51	10.20	8.92	9.50	11.62	12.08	14.20	16.12
	105	3.88	4.80	5.25	5.60	6.95	7.58	7.41	8.80	9.91	8.58	9.95	11.42	11.50	14.70	15.69
	110	3.67	4.90	5.07	5.38	7.20	7.43	7.04	9.09	9.63	8.25	10.40	11.22	10.92	15.20	15.25
	120	3.25	5.20	4.73	4.92	7.60	7.08	6.29	9.61	9.03	7.55	11.30	10.77	9.78	16.00	14.34

**LEGEND**

- Cap.** — Capacity (tons)
- kW** — Compressor Power Input
- SCT** — Saturated Condensing Temperature (F)
- SST** — Saturated Suction Temperature (F)
- THR** — Total Heat Rejection (tons)

\*Refer to capacity notes, page 8.

NOTE: To ensure proper motor cooling, it is required that all 6-cylinder compressors operating with R-507/404A at -10 F SST or below have one of the 2 unloaders disconnected. Cylinder head fan required at SST of -20 F and below for R-507/404A for all compressors.

# Performance data (cont)



## 07E CONDENSING UNIT CAPACITIES (Tons)\* R-22

SST	SCT	07EA022			07EB027			07EB033			07ED044		
		Cap.	kW	THR	Cap.	kW	THR	Cap.	kW	THR	Cap.	kW	THR
0	90	9.26	12.30	12.76	11.52	15.45	15.92	12.84	17.76	17.90	17.36	24.40	24.32
	100	8.46	12.90	12.14	10.47	16.08	15.05	11.62	18.28	16.83	16.06	25.27	23.26
	105	8.09	13.15	11.83	9.96	16.34	14.62	11.01	18.42	16.26	15.42	25.63	22.73
	110	7.71	13.40	11.53	9.46	16.59	14.19	10.40	18.55	15.68	14.78	25.99	22.19
	120	6.97	13.90	10.93	8.50	16.97	13.34	9.16	18.55	14.45	13.54	26.55	21.11
10	90	12.01	13.40	15.83	15.20	17.15	20.09	16.88	19.70	22.49	22.39	27.11	30.12
	100	11.04	14.20	15.09	13.90	18.12	19.06	15.49	20.69	21.39	20.79	28.42	28.89
	105	10.58	14.55	14.73	13.27	18.54	18.56	14.78	21.07	20.79	20.01	28.98	28.27
	110	10.12	14.90	14.36	12.65	18.96	18.05	14.08	21.44	20.19	19.23	29.53	27.65
	120	9.21	15.60	13.66	11.45	19.64	17.04	12.66	21.92	18.90	17.70	30.47	26.38
20	90	15.32	14.30	19.40	19.71	18.53	24.99	21.65	21.24	27.70	28.47	29.50	36.88
	100	14.14	15.40	18.53	18.11	19.92	23.79	20.06	22.73	26.53	26.52	31.34	35.45
	105	13.58	15.85	18.10	17.34	20.54	23.19	19.24	23.36	25.90	25.57	32.15	34.73
	110	13.02	16.30	17.66	16.56	21.15	22.59	18.43	23.99	25.27	24.61	32.96	34.00
	120	11.91	17.20	16.81	15.08	22.20	21.40	16.79	24.99	23.91	22.73	34.35	32.52
30	90	19.26	14.80	23.48	25.16	19.49	30.72	27.24	22.26	33.59	35.72	31.40	44.67
	100	17.84	16.20	22.46	23.21	21.35	29.30	25.41	24.30	32.33	33.37	33.87	43.03
	105	17.16	16.85	21.96	22.27	22.20	28.59	24.48	25.21	31.66	32.22	34.98	42.19
	110	16.47	17.50	21.46	21.32	23.04	27.89	23.54	26.11	30.98	31.06	36.09	41.35
	120	15.14	18.70	20.47	19.50	24.53	26.49	21.65	27.67	29.54	28.78	38.05	39.63
40	90	23.89	15.00	28.17	31.67	19.88	37.34	33.74	22.68	40.20	44.29	32.64	53.59
	100	22.20	16.80	26.99	29.32	22.29	35.67	31.64	25.30	38.85	41.48	35.85	51.70
	105	21.38	17.60	26.40	28.18	23.40	34.85	30.56	26.50	38.12	40.10	37.31	50.73
	110	20.56	18.40	25.81	27.04	24.50	34.02	29.49	27.70	37.39	38.71	38.76	49.76
	120	18.96	19.90	24.64	24.82	26.50	32.38	27.32	29.85	35.83	35.98	41.38	47.78
50	90	29.30	14.80	33.52	39.34	19.60	44.93	41.22	22.40	47.61	54.30	33.10	63.73
	100	27.30	16.90	32.11	36.54	22.60	42.98	38.82	25.60	46.12	50.98	37.10	61.56
	105	26.33	17.90	31.43	35.18	24.00	42.02	37.60	27.15	45.33	49.34	38.95	60.44
	110	25.36	18.90	30.75	33.82	25.40	41.06	36.37	28.70	44.55	47.70	40.80	59.33
	120	23.46	20.80	29.39	31.17	28.00	39.15	33.88	31.40	42.83	44.46	44.20	57.06

### LEGEND

- Cap.** — Capacity (tons)
- kW** — Compressor Power Input
- SCT** — Saturated Condensing Temperature (F)
- SST** — Saturated Suction Temperature (F)
- THR** — Total Heat Rejection (tons)

\*Refer to capacity notes, page 8.

NOTE: To ensure proper motor cooling, it is required that all 6-cylinder compressors operating with R-22 at 20 F SST or below have one of the 2 unloaders disconnected. Cylinder head fan required at SST of 0° F and below for R-22 for all compressors.



**07E CONDENSING UNIT CAPACITIES (Tons)\* (cont)**  
**R-134a**

SST	SCT	07EA022			07EB027			07EB033			07ED044		
		Cap.	kW	THR	Cap.	kW	THR	Cap.	kW	THR	Cap.	kW	THR
0	90	4.75	6.83	6.69	6.17	8.52	8.60	7.55	10.30	10.49	10.14	14.70	14.33
	100	4.22	6.88	6.18	5.32	8.39	7.71	6.73	10.40	9.69	9.13	14.90	13.38
	105	3.96	6.87	5.92	4.89	8.24	7.24	6.31	10.40	9.28	8.64	14.95	12.91
	110	3.71	6.85	5.66	4.47	8.08	6.78	5.90	10.40	8.86	8.16	15.00	12.43
	120	3.21	6.73	5.13	3.64	7.56	5.80	5.06	10.10	7.94	7.21	14.90	11.46
10	90	6.52	7.84	8.76	8.73	10.10	11.61	10.29	11.90	13.68	13.75	17.00	18.60
	100	5.88	8.04	8.17	7.73	10.30	10.66	9.33	12.30	12.84	12.50	17.40	17.46
	105	5.56	8.10	7.87	7.23	10.25	10.15	8.85	12.40	12.38	11.89	17.55	16.89
	110	5.25	8.15	7.57	6.73	10.20	9.64	8.36	12.50	11.92	11.28	17.70	16.32
	120	4.63	8.17	6.96	5.74	10.00	8.59	7.38	12.60	10.97	10.09	17.90	15.19
20	90	8.72	8.78	11.22	11.86	11.55	15.15	13.59	13.20	17.36	18.21	19.10	23.66
	100	7.93	9.17	10.54	10.67	12.04	14.10	12.47	13.97	16.45	16.66	19.90	22.34
	105	7.54	9.31	10.20	10.08	12.19	13.55	11.90	14.27	15.96	15.91	20.25	21.68
	110	7.15	9.45	9.85	9.49	12.33	13.00	11.33	14.56	15.48	15.15	20.60	21.02
	120	6.40	9.63	9.14	8.32	12.40	11.85	10.18	14.96	14.44	13.67	21.00	19.65
30	90	11.40	9.57	14.13	15.64	12.69	19.25	17.54	14.25	21.61	23.67	21.10	29.68
	100	10.44	10.20	13.34	14.23	13.57	18.10	16.22	15.40	20.61	21.76	22.30	28.12
	105	9.96	10.45	12.94	13.53	13.91	17.49	15.55	15.89	20.07	20.83	22.80	27.32
	110	9.49	10.70	12.54	12.83	14.24	16.89	14.87	16.37	19.54	19.89	23.30	26.53
	120	8.56	11.10	11.72	11.44	14.68	15.62	13.52	17.15	18.40	18.06	24.20	24.96
40	90	14.64	10.10	17.52	20.17	13.40	23.99	22.24	14.90	26.49	30.28	22.70	36.75
	100	13.47	11.00	16.61	18.50	14.80	22.72	20.67	16.50	25.38	27.94	24.50	34.93
	105	12.90	11.40	16.14	17.67	15.35	22.05	19.88	17.20	24.78	26.80	25.25	33.99
	110	12.32	11.80	15.68	16.84	15.90	21.37	19.08	17.90	24.19	25.65	26.00	33.06
	120	11.19	12.40	14.72	15.18	16.70	19.94	17.48	19.10	22.92	23.40	27.20	31.15
50	90	18.53	10.40	21.50	25.57	13.64	29.46	27.81	15.07	32.11	38.23	23.90	45.04
	100	17.12	11.61	20.43	23.60	15.49	28.01	25.95	17.13	30.83	35.39	26.20	42.85
	105	16.42	12.14	19.88	22.61	16.29	27.25	25.01	18.07	30.16	33.98	27.25	41.75
	110	15.72	12.67	19.33	21.62	17.09	26.49	24.06	19.00	29.48	32.58	28.30	40.65
	120	14.34	13.58	18.21	19.64	18.44	24.90	22.15	20.67	28.05	29.83	30.10	38.40

LEGEND

\*Refer to capacity notes, page 8.

- Cap. — Capacity (tons)
- kW — Compressor Power Input
- SCT — Saturated Condensing Temperature (F)
- SST — Saturated Suction Temperature (F)
- THR — Total Heat Rejection (tons)

# Performance data (cont)



## 07E CONDENSING UNIT CAPACITIES (Tons)\* (cont) R-507/404A

SST	SCT	07EA022			07EB027			07EB033			07ED044		
		Cap.	kW	THR	Cap.	kW	THR	Cap.	kW	THR	Cap.	kW	THR
-30	90	5.01	11.00	8.15	6.31	12.80	9.96	7.12	15.30	11.48	9.37	20.60	15.24
	100	4.45	10.90	7.56	5.51	12.70	9.13	6.30	15.10	10.60	8.34	20.60	14.21
	105	4.16	10.80	7.23	5.13	12.60	8.72	5.89	14.95	10.15	7.81	20.50	13.65
	110	3.86	10.70	6.91	4.74	12.50	8.30	5.47	14.80	9.69	7.29	20.40	13.10
	120	3.23	10.30	6.17	3.99	12.10	7.44	4.63	14.30	8.70	6.25	20.00	11.95
-20	90	6.87	13.00	10.58	8.68	15.40	13.07	9.85	18.30	15.07	12.53	24.30	19.46
	100	6.23	13.20	10.00	7.68	15.50	12.10	8.88	18.40	14.12	11.28	24.60	18.29
	105	5.89	13.25	9.67	7.20	15.45	11.60	8.38	18.35	13.61	10.65	24.65	17.67
	110	5.56	13.30	9.35	6.71	15.40	11.10	7.88	18.30	13.09	10.02	24.70	17.06
	120	4.84	13.20	8.60	5.76	15.20	10.09	6.85	18.10	12.00	8.74	24.70	15.78
-10	90	9.04	14.90	13.29	11.57	18.00	16.70	13.12	21.20	19.16	16.31	28.10	24.31
	100	8.30	15.40	12.69	10.34	18.30	15.56	11.95	21.70	18.14	14.80	28.80	23.00
	105	7.91	15.60	12.36	9.74	18.40	14.98	11.35	21.80	17.56	14.03	29.05	22.31
	110	7.52	15.80	12.02	9.13	18.50	14.40	10.74	21.90	16.98	13.26	29.30	21.61
	120	6.68	16.00	11.24	7.94	18.50	13.21	9.50	22.00	15.77	11.71	29.60	20.15
0	90	11.57	16.70	16.33	15.09	20.70	20.98	16.99	24.20	23.89	20.79	32.10	29.94
	100	10.70	17.50	15.69	13.57	21.30	19.64	15.59	24.90	22.69	18.97	33.10	28.40
	105	10.24	17.85	15.33	12.82	21.55	18.96	14.86	25.25	22.06	18.04	33.55	27.60
	110	9.78	18.20	14.97	12.06	21.80	18.28	14.14	25.60	21.44	17.11	34.00	26.80
	120	8.80	18.70	14.13	10.58	22.00	16.85	12.63	26.00	20.04	15.22	34.70	25.11
10	90	14.49	18.40	19.74	19.26	23.40	25.93	21.54	26.80	29.17	26.05	35.80	36.25
	100	13.46	19.50	19.02	17.42	24.30	24.35	19.93	28.20	27.97	23.87	37.50	34.55
	105	12.92	20.00	18.62	16.51	24.70	23.55	19.02	28.75	27.21	22.75	38.20	33.64
	110	12.37	20.50	18.22	15.59	25.10	22.74	18.11	29.30	26.46	21.64	38.90	32.73
	120	11.23	21.20	17.27	13.78	25.70	21.10	16.30	30.00	24.85	19.38	39.90	30.75
20	90	17.85	19.90	23.52	24.19	26.10	31.63	26.82	29.40	35.20	32.19	39.60	43.47
	100	16.64	21.30	22.71	21.98	27.40	29.79	24.82	31.30	33.74	29.59	41.80	41.51
	105	16.00	21.90	22.24	20.88	27.95	28.85	23.79	32.05	32.92	28.27	42.75	40.45
	110	15.36	22.50	21.78	19.78	28.50	27.91	22.76	32.80	32.10	26.95	43.70	39.40
	120	14.02	23.50	20.72	17.60	29.50	26.01	20.62	34.00	30.31	24.26	45.10	37.11

### LEGEND

- Cap. — Capacity (tons)
- kW — Compressor Power Input
- SCT — Saturated Condensing Temperature (F)
- SST — Saturated Suction Temperature (F)
- THR — Total Heat Rejection (tons)

\*Refer to capacity notes, page 8.

NOTE: To ensure proper motor cooling, it is required that all 6-cylinder compressors operating with R-507/404A at -10 F SST or below have one of the 2 unloaders disconnected. Cylinder head fan required at SST of -20 F and below for R-507/404A for all compressors.



**CONDENSER CAPACITY AND FLOW RATES**

**R-22 (at 105 F) CONDENSING TEMPERATURE WITH .0005 TOTAL FOULING FACTOR**

CONDENSER PART NUMBER	GPM	ΔP	TOTAL HEAT OF REJECTION (Btuh) AT SPECIFIED GTD (F)					
			15° GTD	20° GTD	25° GTD	30° GTD	35° GTD	40° GTD
P701-0605CX	4	0.4	25,876	34,346	42,623	50,894	59,047	67,175
	7	1.2	40,573	53,575	66,384	79,002	91,433	103,691
	10	2.3	52,268	68,835	85,046	100,906	116,676	131,981
	13	3.7	61,854	80,982	100,018	118,330	136,385	154,717
	16	5.5	69,544	91,211	112,212	132,917	153,006	172,113
	19	7.5	76,284	99,334	122,457	144,354	165,956	187,291
	22	9.9	81,725	106,541	130,963	153,913	177,705	200,067
P701-0607CX	8	1.1	47,149	62,256	77,174	91,893	106,399	120,699
	11	2.0	59,478	78,384	96,924	115,096	133,011	150,692
	14	3.1	69,930	91,849	113,217	134,266	155,035	175,071
	17	4.4	78,722	103,175	126,925	150,325	173,419	195,531
	20	6.0	86,329	112,806	138,858	164,108	189,023	213,636
	23	7.8	92,626	121,152	148,694	176,400	202,651	228,576
	26	9.7	98,283	128,605	157,814	186,617	213,715	240,462
P701-0610CX	10	0.7	62,373	82,660	102,457	122,287	141,818	160,973
	15	1.5	85,363	112,618	139,447	165,852	191,893	217,417
	20	2.5	104,246	137,064	169,356	201,201	232,648	263,167
	25	3.7	120,229	157,722	194,628	230,151	265,167	299,727
	30	5.2	133,498	174,765	215,383	254,191	292,454	330,227
	35	6.9	144,917	189,123	232,616	274,693	317,053	357,244
	40	8.8	154,191	202,443	248,020	292,947	337,309	379,093
P701-0615CX	15	1.5	97,523	129,183	160,807	191,540	222,649	252,631
	20	2.6	122,585	161,948	200,943	239,541	277,305	314,905
	25	3.8	144,524	190,575	235,938	280,611	324,664	368,164
	30	5.4	163,696	215,528	266,356	316,465	365,659	414,241
	35	7.1	180,523	237,619	293,047	347,672	401,108	453,874
	40	9.0	195,650	256,985	316,774	374,406	432,610	488,748
	45	11.2	208,992	273,709	336,575	398,539	459,727	520,228
P701-0620CX	15	1.1	101,136	134,027	166,805	199,111	231,647	263,717
	20	1.8	128,374	170,328	211,585	252,256	292,405	332,450
	25	2.8	153,231	202,435	251,179	299,427	346,631	393,631
	30	3.8	175,497	231,510	286,665	341,092	394,800	447,790
	35	5.1	195,393	257,457	318,265	378,366	437,215	495,867
	40	6.5	213,379	280,670	346,918	411,868	475,987	538,365
	45	8.1	229,519	301,699	372,792	441,714	509,707	576,875
P701-0625AX	25	0.7	143,279	189,183	234,342	278,853	322,685	365,918
	35	1.2	182,367	239,870	296,448	352,230	407,298	460,716
	45	1.9	214,674	281,873	347,257	412,496	475,260	537,191
	55	2.7	241,762	316,860	389,648	462,572	532,195	600,918
	65	3.7	265,014	346,304	426,315	502,128	580,044	650,648
	75	4.8	283,919	371,578	456,014	539,267	617,577	694,849
	85	6.0	300,803	391,753	483,509	569,523	654,414	738,299
P701-0840AX	40	0.6	231,569	305,830	378,918	450,965	521,942	591,910
	60	1.3	309,640	408,013	504,258	597,595	689,529	780,189
	80	2.2	372,012	487,692	603,017	713,803	819,900	927,725
	100	3.3	422,189	552,832	681,449	806,061	924,384	1,045,822
	120	4.5	463,073	608,148	745,178	880,222	1,013,523	1,139,022
	140	6.0	500,930	651,392	799,425	941,663	1,082,025	1,220,703
P701-0850AX	50	1.1	296,824	392,331	486,264	578,850	670,228	760,485
	70	1.9	378,460	498,635	616,474	731,993	845,905	958,367
	90	3.0	445,812	585,635	723,306	857,721	987,383	1,118,374
	110	4.4	502,450	656,782	808,565	958,209	1,105,984	1,247,414
	130	5.9	548,504	717,949	884,783	1,046,464	1,200,062	1,357,777
	150	7.6	587,833	770,641	947,107	1,117,473	1,285,647	1,451,868
P701-1065AX	100	1.6	497,687	655,475	808,070	958,376	1,106,650	1,249,634
	120	2.2	558,019	731,538	904,525	1,070,705	1,229,850	1,391,588
	140	2.9	609,337	799,341	986,472	1,165,035	1,341,130	1,514,993
	160	3.7	655,460	856,550	1,054,440	1,249,623	1,434,672	1,617,293
	180	4.6	694,609	912,222	1,117,768	1,320,333	1,520,285	1,708,533
	200	5.6	731,968	955,731	1,170,825	1,388,102	1,592,145	1,793,632
	220	6.6	764,169	996,751	1,225,710	1,445,627	1,650,631	1,865,118

**LEGEND**

- GPM** — Gallons Per Minute
- GTD** — Greatest Temperature Difference (F)
- ΔP** — Change In Pressure (psi)

NOTE: GTD is the difference between the condensing temperature and the inlet water temperature.

# Performance data (cont)



## CONDENSER CAPACITY AND FLOW RATES (cont)

R-134a (at 105 F) CONDENSING TEMPERATURE WITH .0005 TOTAL FOULING FACTOR

CONDENSER PART NUMBER	GPM	TOTAL HEAT OF REJECTION (Btuh) AT SPECIFIED GTD (F)			
		15° GTD		40° GTD	
		ΔP	THR	ΔP	THR
P701-0605CX	4	0.43	25,765	0.44	66,796
	22	9.69	80,103	10.06	194,621
P701-0607CX	8	1.08	46,790	1.12	119,453
	26	9.55	96,365	9.90	234,015
P701-0610CX	10	0.69	62,074	0.71	159,840
	40	8.57	151,198	8.93	369,084
P701-0615CX	15	1.50	96,870	1.56	251,118
	42	9.64	197,657	10.04	490,954
P701-0620CX	15	1.07	100,679	1.11	262,189
	45	7.88	226,118	8.18	565,547
P701-0625AX	25	0.65	142,136	0.68	361,781
	85	5.83	294,664	6.12	717,671
P701-0630AX	30	0.71	169,332	0.74	430,974
	90	5.16	328,979	5.41	804,474
P701-0840AX	40	0.61	229,741	0.64	585,906
	140	5.83	487,215	6.10	1,186,682
P701-0850AX	50	1.04	294,477	1.08	752,237
	150	7.41	576,477	7.77	1,414,060
P701-1065AX	100	1.55	491,308	1.62	1,231,276
	220	6.44	748,299	6.75	1,811,718

**LEGEND**

- GPM — Gallons Per Minute
- GTD — Greatest Temperature Difference (F)
- THR — Total Heat of Rejection
- ΔP — Change In Pressure (psi)

NOTE: GTD is the difference between the condensing temperature and the inlet water temperature.

R-507/404A (at 105 F) CONDENSING TEMPERATURE WITH .0005 TOTAL FOULING FACTOR

CONDENSER PART NUMBER	GPM	TOTAL HEAT OF REJECTION (Btuh) AT SPECIFIED GTD (F)			
		15° GTD		40° GTD	
		ΔP	THR	ΔP	THR
P701-0605CX	4	0.43	25,582	0.44	66,021
	22	9.69	76,649	10.07	186,012
P701-0607CX	8	1.08	46,132	1.12	117,295
	26	9.56	92,293	9.91	223,811
P701-0610CX	10	0.69	61,395	0.71	157,440
	40	8.57	145,885	8.93	353,223
P701-0615CX	15	1.50	96,015	1.56	247,451
	42	9.64	191,905	10.05	471,557
P701-0620CX	15	1.07	99,591	1.11	258,740
	45	7.88	220,172	8.19	547,035
P701-0625AX	25	0.65	140,108	0.68	355,018
	85	5.83	283,698	6.13	680,343
P701-0630AX	30	0.71	166,854	0.74	422,296
	90	5.17	317,371	5.41	764,927
P701-0840AX	40	0.61	226,617	0.64	575,438
	140	5.83	469,123	6.12	1,133,013
P701-0850AX	50	1.04	290,154	1.08	737,603
	150	7.41	556,359	7.78	1,346,139
P701-1065AX	100	1.55	481,415	1.62	1,195,454
	220	6.44	719,947	6.75	1,727,631

**LEGEND**

- GPM — Gallons Per Minute
- GTD — Greatest Temperature Difference (F)
- THR — Total Heat of Rejection
- ΔP — Change In Pressure (psi)

NOTE: GTD is the difference between the condensing temperature and the inlet water temperature.



**RATING BASIS AND CAPACITY MULTIPLIERS**

SST	RATED SUCTION GAS TEMP	ACTUAL SUCTION GAS TEMP TO COMPR (F)										
		-30	-20	-10	0	10	20	30	40	50	60	65
-30	65	.810	.830	.850	.870	.890	.910	.930	.950	.970	.990	1.000
-20			.830	.850	.870	.890	.910	.930	.950	.970	.990	1.000
-10				.850	.870	.890	.910	.930	.950	.970	.990	1.000
				.930	.939	.949	.958	.967	.977	.986	.995	1.000
0					.870	.890	.910	.930	.950	.970	.990	1.000
					.940	.949	.958	.968	.977	.986	.995	1.000
10						.890	.910	.930	.950	.970	.990	1.000
						.950	.959	.968	.977	.986	.995	1.000
20							.910	.930	.950	.970	.990	1.000
							.960	.969	.978	.987	.996	1.000
30								.930	.950	.970	.990	1.000
							.970	.979	.987	.996	1.000	
40								.950	.970	.990	1.000	
								.987	.992	.997	1.000	
50									.970	.990	1.000	
									.997	.999	1.000	

LEGEND

□ R-507/404A

■ R-134a

SST — Saturated Suction Temperature (F)

**COMPRESSOR CAPACITY CONTROL REDUCTION STEPS\* AND PART-LOAD PERFORMANCE**

COMPRESSOR 06D, 06E	NO. OF CONTR CYL	% Full Load Capacity			
		100	67	49	32
		% Full Load kW			
		100	73	57	46
Number of Active Cylinders					
ALL 4 CYLINDER MODELS	2	4	—	2	—
ALL 6 CYLINDER MODELS	4	6	4	—	2

\*Compressor cylinders unload in response to a self-contained suction-pressure controlled unloader valve(s) for 06D and 06E compressors. When suction pressure drops below unloader set point, cylinders unload. When suction pressure rises above cylinder load set point pressure, cylinders return to operation. Capacity control unloader set points and differential (load point – unload point) are adjustable.

# Electrical data



## COMPRESSOR MOTOR\*

COMPRESSOR PART NUMBER 06D		VOLTAGE (3 Ph-60 Hz)	HP	MCC	RLA	LRA	MOTOR WINDING RESISTANCE (Ohms)
M	808	575	3	7	5	28.4	5.0
		208/230		17.4	12.4	71	0.78
		460		8.7	6.2	35.5	3.1
	313	575	5	10.8	7.7	40	3.3
		208/230		27	19.3	100	0.5
		460		13.5	9.6	50	2.1
	818	575	6.5	17.6	12.6	64	2.6
		208/230		44	31.4	160	0.42
		460		22	15.7	80	1.7
A	825	575	7.5	22.2	15.9	79	2.0
		208/230		55.5	39.6	198	0.31
		460		27.8	19.8	99	1.3
	328	575	10	25	17.9	91	1.7
		208/230		62	44.3	228	0.26
		460		31	22.1	114	1.0
	537	575	15	32	22.9	96	1.2
		208/230		89	63.6	266	0.18
		460		40	28.6	120	0.72

### LEGEND

**LRA** — Locked Rotor Amps  
**MCC** — Maximum Continuous Current  
**RLA** — Rated Load Amps

\*Refer to physical data table to match compressor with correct water-cooled condensing unit.

### NOTES:

1. RLA (rated load amps) value shown is:  $MCC \div 1.40 = RLA$ .
2. For minimum contactor sizing, use RLA value determined by:  $MCC \div 1.40 = RLA$ .

3. For wiring sizing, the RLA value can be determined by:  $MCC \div 1.56 = RLA$ .
4. Compressor operating amps at any specific conditions can only be determined from a performance curve.
5. RLA values for 06D compressor protected by a calibrated circuit breaker will depend on must-trip value of circuit breaker.
6. Ohm values shown for resistance are approximate and shown for reference only. Motors from different vendors and motors of different efficiencies can differ up to 15% from data shown.
7. Electrical data for compressor part numbers 06DR and 50 Hz models (not shown) are available from Carrier Sales Representative.

### ALLOWABLE OPERATING RANGES

NOMINAL VOLTAGE	MAXIMUM	MINIMUM
208/230	254	187
460	529	414
575	661	518



**COMPRESSOR MOTOR WITH CIRCUIT BREAKER\***

COMPRESSOR MOTOR DATA									CIRCUIT BREAKER				
Compressor Part Number 06E	Voltage (3 Ph - 60 Hz)	Hp	Maximum Must Trip Amps	Maximum RLA	LRA-XL	LRA-PW (first winding)	Motor Winding Resistance (Ohms)	Recommended Circuit Breaker Part No.	MHA	MTA	LRA	Recommended RLA	
A	250	208/230	20	108	87	345	207	0.32	HH83XB336 XA461 XA424	91	104	350	74.3
		575		45	36	120	72	2.2		33	38	124	27.1
		460		54	44	173	104	1.3		42	49	175	35
	265	208/230	25	140	112	446	268	0.27	HH83XC509 XA469 XA426	110	127	420	90.7
		575		57	46	164	98	1.6		46	53	164	37.9
		460		70	56	223	134	1.1		55	643	210	45.7
	275	208/230	30	168	135	506	304	0.22	HH83XC539 XA430 XA425	142	163	507	116.4
		575		65	52	176	106	1.3		50	58	168	41.4
		460		84	68	253	152	0.9		63	73	210	52.1
	299	208/230	40	236	189	690	414	0.15	HH83XC537 XA551 XA550	187	215	636	153.6
		575		94	75	276	165	1.0		74	85	236	60.7
		460		118	95	345	207	0.58		92	106	295	75.7

**LEGEND**

- LRA** — Locked Rotor Amps
- MHA** — Must Hold Amps
- MTA** — Must-Trip Amps
- PW** — Part-Winding (Start)
- RLA** — Rated Load Amps
- XL** — Across-the-Line (Start)

\*Refer to physical data table to match compressor with correct water-cooled condensing unit.

**NOTES:**

1. Compressor MTA and RLA values are maximum figures.
2. LRA values for PW second winding = 1/2 the LRA – XL value.
3. 3-Pole XL circuit breakers shown, other 3-Pole XL alternates and 6-Pole PW breakers available. Terminal lugs for circuit breakers available in package 06EA660152 (not shown).

4. Recommended RLA value shown is determined by: circuit breaker must trip value ÷ 1.40. Use this recommended (and minimum) RLA value to determine nameplate stamping, minimum contactor sizing, and wire sizing. **RECOMMENDED RLA FOR 06E COMPRESSORS EQUALS: MUST-TRIP (MTA) OF CARLYLE APPROVED OVERCURRENT DEVICE BEING USED ÷ 1.40**
5. Compressor operating amps at any specific condition can only be determined from a performance curve.
6. Ohm values for resistance are approximate and shown for reference purposes only. Motors from different vendors and motors of different efficiencies can differ up to 15% from data shown.
7. Electrical data for compressor part numbers 06ER, 06EM and 50 Hz models (not shown) are available from Carrier Sales Representative.

**ALLOWABLE OPERATING RANGES**

NOMINAL VOLTAGE	MAXIMUM	MINIMUM
208/230	254	187
460	529	414
575	661	518



### 07E WIRING SCHEMATIC

Single pumpout control is standard on 07E condensing units. This method of control incorporates a liquid line solenoid valve and prevents refrigerant migration to the compressor by allowing the unit to shut off only after all refrigerant has been removed from the evaporator (compressor shuts off on low-pressure switch). Single pumpout

control should not be used on direct-expansion cooler applications. For these applications, rewire as shown in the schematic wiring diagram. This provides minimum protection (stops compressor, closes liquid line solenoid valve, and energizes crankcase heaters simultaneously).

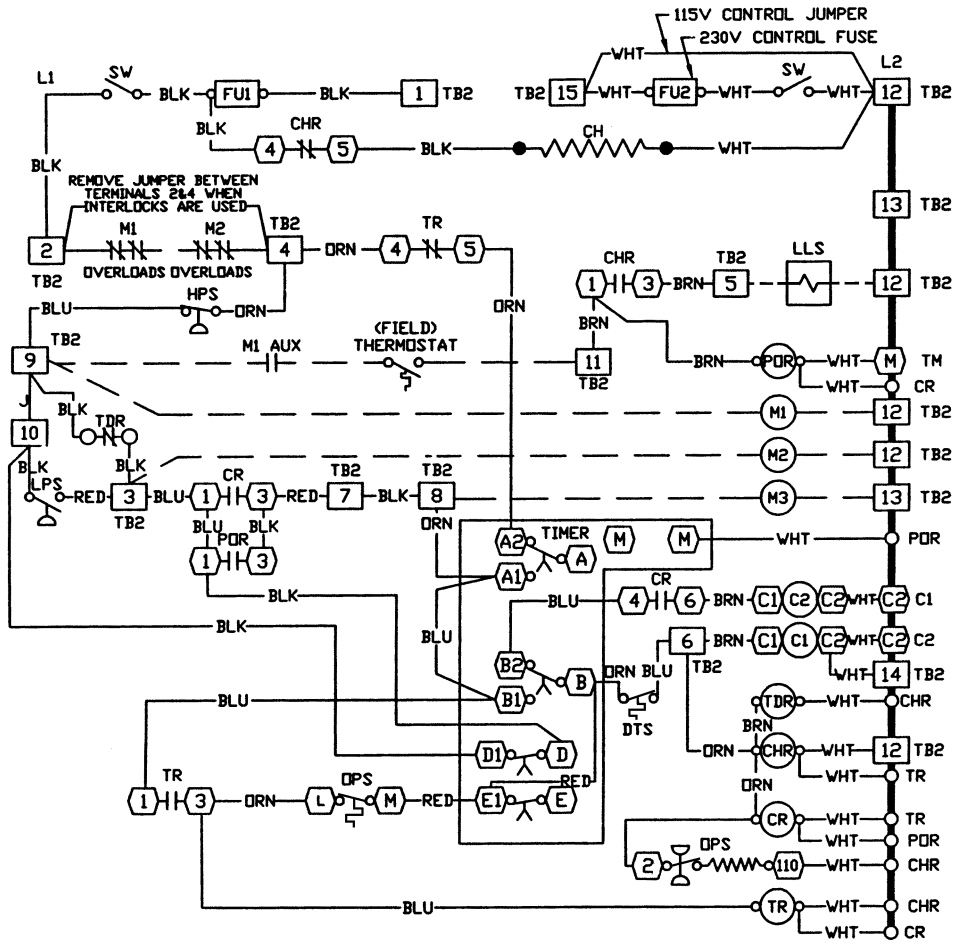

#### FIELD CONNECTION WHEN APPLIED WITH DX COOLER

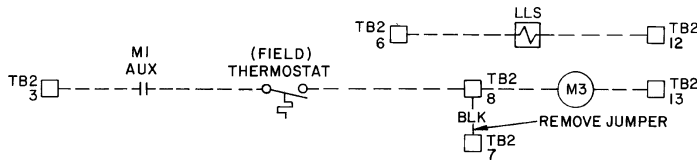







# Typical wiring schematics (cont)



## LEGEND AND NOTES FOR TYPICAL WIRING SCHEMATICS 07D AND 07E

### LEGEND

<b>AUX</b>	—	Auxiliary
<b>C</b>	—	Compressor Contactor
<b>C1</b>	—	Compressor Contactor (XL start and first step of PW start)
<b>C2</b>	—	Compressor Contactor (PW second step)
<b>CH</b>	—	Crankcase Heater
<b>CHR</b>	—	Crankcase Heater Relay
<b>CR</b>	—	Control Relay
<b>DTS</b>	—	Discharge Temperature Sensor
<b>DX</b>	—	Direct Expansion
<b>EQUIP</b>	—	Equipment
<b>FU</b>	—	Fuse
<b>GND</b>	—	Ground
<b>HPS</b>	—	High-Pressure Switch
<b>IP</b>	—	Internal Protector
<b>LLS</b>	—	Liquid Line Solenoid Valve
<b>LPS</b>	—	Low-Pressure Switch
<b>M1</b>	—	Evaporator Fan or Chilled Water Pump
<b>M2</b>	—	Cooling Tower Pump
<b>M3</b>	—	Cooling Tower Fan
<b>NEC</b>	—	National Electrical Code
<b>OL</b>	—	Overload
<b>OPS</b>	—	Oil-Pressure Switch

<b>POR</b>	—	Pumpout Relay
<b>PW</b>	—	Part Winding
<b>SW</b>	—	Start-Stop-Reset Switch
<b>TB</b>	—	Terminal Block
<b>TDR</b>	—	Time Delay Relay
<b>TM</b>	—	Timer Motor
<b>TR</b>	—	Timer Relay
<b>XL</b>	—	Across-the-Line
	—	Terminal Block Connector
	—	Unmarked Terminal
	—	Marked Terminal
	—	Factory Wiring
	—	Field Control Wiring
	—	To indicate common potential only; not to represent wiring.
	—	Splice

### NOTES:

1. Factory wiring is in compliance with NEC. Any field modifications or additions must be in compliance with all applicable codes. Use copper, copper-clad aluminum for field power supply only.
2. Field power supply wiring must be 75 C minimum.
3. Compressor thermally protected. Three-phase motors are protected against primary single-phasing condition.
4. Pilot duty control must be field supplied. Minimum contact rating must be 25 va.
5. 60 Hz units have 120 volt control circuit. 50 Hz units have 230 volt control circuit. A separate source of supply at the correct voltage must be field supplied through a fused disconnect device with a

maximum rating of 15 A to TB2 connections  (Hot Side) and

 (Neutral).

6. Open control circuit disconnect switch for servicing only. Disconnect must remain closed for crankcase heater to operate.
7. A transformer of the following rating may be field supplied for 60 Hz units: 350 va.
8. Transformer must be fused and grounded per applicable codes.
9. If any of the original wiring furnished must be replaced, it must be replaced with 90 C wire or its equivalent.

# Typical piping and wiring

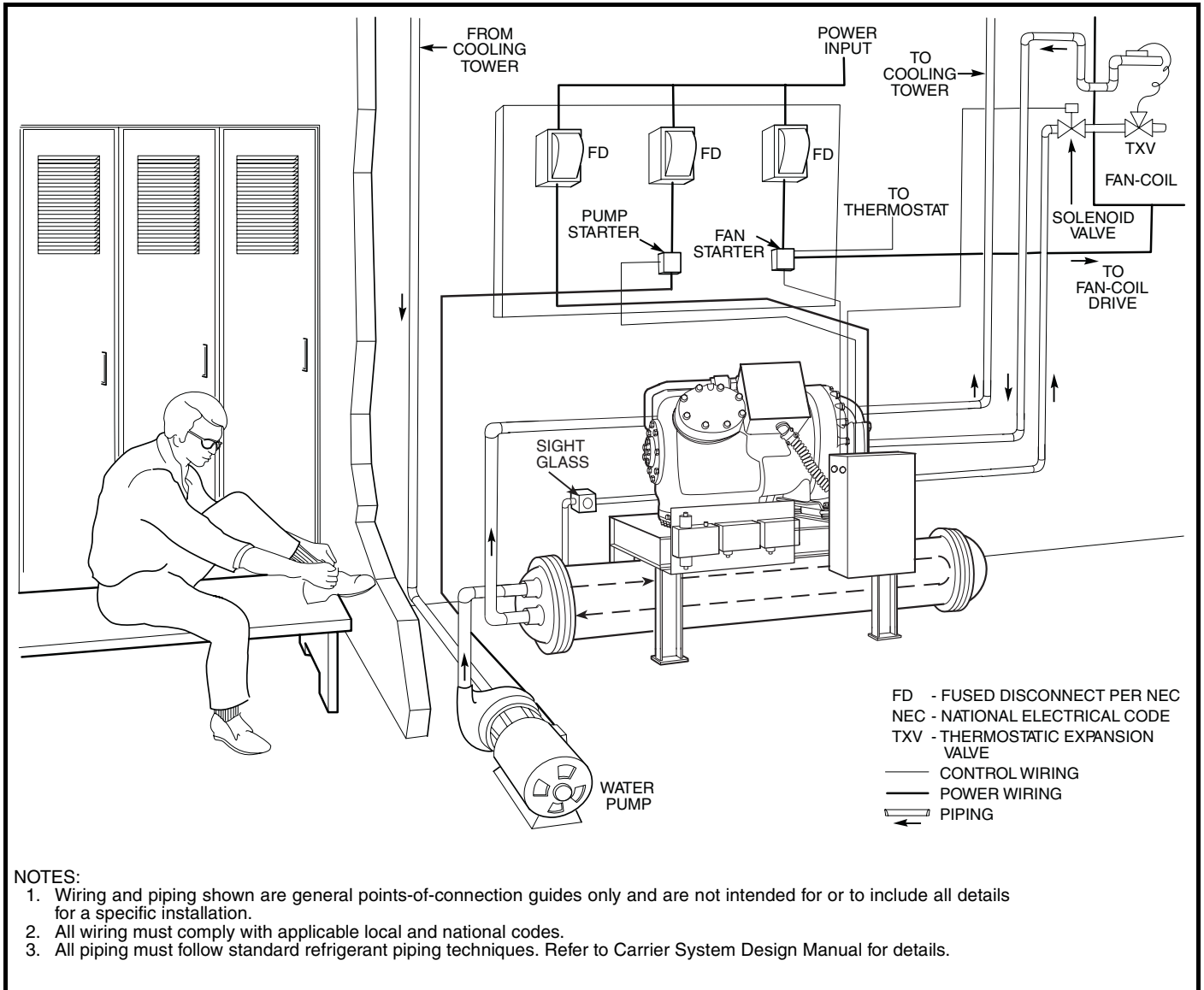

# Application data



**Adequate lubrication** depends on proper oil return to compressor (especially during unloaded operation) and keeping liquid refrigerant out of crankcase (refrigerant dilutes oil).

**Correct system piping design** prevents gravity flow of refrigerant to compressor while permitting oil return. Refer to Carrier System Design Manual for correct refrigerant piping techniques.

**Crankcase heater** energized and **liquid line solenoid** closed during shutdown periods restrict refrigerant migration to compressor and absorption of refrigerant by the oil (minimum protection). A discharge line check valve prevents refrigerant migration from condenser to compressor and should be installed on air-cooled applications where condenser or receiver ambient temperature is at or above compressor ambient temperature.

**Single pumpout control** incorporates a liquid line solenoid valve and prevents refrigerant migration by allowing unit to shut off only after all refrigerant has been removed from evaporator. (Compressor shuts off on low-pressure cutout.)

**Automatic pumpdown control** allows compressor to cycle on for short intervals during normally "off" periods. This periodically removes any refrigerant from evaporator which may have accumulated.

This control should not be used with 06D or 06E compressors having cylinder head unloaders.

**Direct-expansion cooler applications** (excluding brine) should not incorporate single pumpout or automatic pump-down control. Crankcase heater and liquid line solenoid (minimum protection) are recommended for these applications.

**Compressors** located in a space subject to low-ambient temperatures require special provision for proper operation during start-up. (Low-ambient temperatures cause compressor to operate at abnormally low suction pressures during start-up.)

Proper operation can be maintained by:

1. Heating the space,
2. A time-delay relay installed to bypass the low-pressure control during start-up, or
3. Use of a suction temperature control to operate compressor, instead of low-pressure control.

**Condensers** are shell-and-tube type with replaceable seamless integral finned copper tubes. They include a pressure relief device, purge connection, liquid line shutoff valve, and an angle valve with pressure connection for water regulating valve.

# Guide specifications — 07D



## 07D Semi-Hermetic Reciprocating Water-Cooled Condensing Unit

### HVAC Guide Specifications

Size Range: **3 to 15 tons**

Carrier Model Number: **07D**

#### Part 1 — General

##### 1.01 SYSTEM DESCRIPTION

Condensing unit utilizing reciprocating type refrigerant compressor and water-cooled condenser.

##### 1.02 QUALITY ASSURANCE

- A. Unit shall comply with ANSI/ASHRAE 15 Safety Code, NEC, and ASME Code.
- B. Unit will be factory run tested to ensure proper performance.

##### 1.03 DELIVERY, STORAGE AND HANDLING

Unit will be stored and handled according to manufacturer's instructions.

#### Part 2 — Products

##### 2.01 EQUIPMENT

###### A. General:

Factory assembled, single piece, refrigerant condensing unit. Contained within the package shall be a semi-hermetic reciprocating compressor, condenser control panel, and all wiring, piping, controls, and necessary safeties prior to field start-up.

###### B. Compressor:

Reciprocating semi-hermetic type only, with shutoff valves, automatically reversible positive displacement oil pump, oil charge, crankcase heater with relay, and suction pressure actuated cylinder unloaders. Compressor and control panel to be factory mounted.

##### C. Condenser:

Condenser shall be of shell-and-tube type with water connections for either maximum or minimum pass. It shall be equipped with a pressure relief device, purge cock, liquid level test valve, and liquid line shut-off valve with back seating port.

##### D. Discharge Muffler:

Unit shall be equipped with a discharge line muffler for noise reduction.

##### E. Controls and Safeties:

1. Included in the control panel are power and control terminal blocks, contactors, control relays, on/off switch, and unit designed to start with controlled cylinders unloaded.
2. Safeties in the control box include high- and low-pressure switches, timer to prevent compressor short cycling, overload relays or circuit breakers, and control circuit fuse.

##### F. Special Features:

Certain standard features are removed and replaced by those features designated by \*. Consult your local Carrier sales office for amending specifications.

###### \* 1. Electric Actuated Unloaders:

Includes all necessary hardware to allow field conversion from suction pressure actuated to electric solenoid actuated unloaders.

###### 2. Control Circuit Transformer:

Eliminate need for external control power source.



## 07E Semi-Hermetic Reciprocating Water-Cooled Condensing Unit

### HVAC Guide Specifications

Size Range: **20 to 40 tons**

Carrier Model Number: **07E**

#### Part 1 — General

##### 1.01 SYSTEM DESCRIPTION

Condensing unit utilizing reciprocating-type refrigerant compressor and water-cooled condenser.

##### 1.02 QUALITY ASSURANCE

- A. Unit shall comply with ANSI/ASHRAE 15 Safety Code, NEC, and ASME Code.
- B. Unit shall be factory run tested to ensure proper performance.

##### 1.03 DELIVERY, STORAGE AND HANDLING

Unit will be stored and handled according to manufacturer's instructions.

#### Part 2 — Products

##### 2.01 EQUIPMENT

###### A. General:

Factory assembled, single piece, refrigerant condensing unit. Contained within the package shall be a semi-hermetic reciprocating compressor, condenser, control panel, all wiring, piping, controls and necessary safeties. Unit shall be mounted on a common structural steel base prior to field start-up.

###### B. Compressor:

Reciprocating semi-hermetic type only, with shutoff valves, automatically reversible positive displacement oil pump, oil charge, crankcase heater with relay, and suction pressure actuated cylinder unloaders. Compressor and control panel to be factory mounted.

###### C. Condenser:

Shell-and-tube, multi-pass with integral finned copper tubes. Shall be factory tested to comply with ASME Code for unfired pressure vessels, ARI Standard 450 for condensers, and ANSI/ASHRAE 15 Safety Code. Equipped with pressure relief, liquid line shutoff, and connection for water regulating valve.

###### D. Discharge Muffler:

Unit shall be equipped with a discharge line muffler for noise reduction.

###### E. Controls and Safeties:

1. Included in the control panel are power and control terminal blocks, contactors, control relays, on/off switch, and unit designed to start with controlled cylinders unloaded.
2. Safeties in the control box include high- and low-pressure switches, timer to prevent compressor short cycling, overload relays or circuit breakers, and control circuit fuse.

###### F. Electrical Requirements:

All control and power wiring between the compressor and control panel shall be completed prior to delivery.

###### G. Special Features:

Certain standard features are removed and replaced by those features designated by \*. Consult your local Carrier sales office for amending specifications.

###### \* 1. Electric Actuated Unloaders:

Includes all necessary hardware to allow field conversion from suction pressure actuated to electric solenoid actuated unloaders.

###### 2. Control Circuit Transformer:

Eliminates need for external control power source.

###### 3. Gage Panel Assembly:

Includes discharge, suction, and oil pressure gages. Panel is for field installation.





**Manufacturer reserves the right to discontinue, or change at any time, specifications or designs without notice and without incurring obligations.**