





















# Wiring Diagrams

50/60 Hz

## WIRING DIAGRAM INDEX

	Fig. No.
Standard Unit Control Schematic 09DK .....	3
Motormaster®, 09DK 208/230 (60 Hz) .....	4
Motormaster, 09DK 460 v, 575 v (60 Hz) .....	5
Fan Cycling Control .....	12

### LEGEND (For All Figures)

<p><b>ATS</b> — Air Temperature Switch</p> <p><b>EQUIP</b> — Equipment</p> <p><b>FC</b> — Fan Contactor</p> <p><b>FM</b> — Fan Motor</p> <p><b>GND</b> — Ground</p> <p><b>TB</b> — Terminal Block Connection</p>	<table style="width: 100%; border-collapse: collapse;"> <tbody> <tr> <td style="text-align: center; width: 20px;"></td> <td>Terminal Block Connection</td> </tr> <tr> <td style="text-align: center;"></td> <td>Marked Terminal</td> </tr> <tr> <td style="text-align: center;"></td> <td>Unmarked Terminal</td> </tr> <tr> <td style="text-align: center;"></td> <td>Factory Wiring</td> </tr> <tr> <td style="text-align: center;"></td> <td>Field Control Wiring</td> </tr> <tr> <td style="text-align: center;"></td> <td>Field Power Wiring</td> </tr> </tbody> </table>		Terminal Block Connection		Marked Terminal		Unmarked Terminal		Factory Wiring		Field Control Wiring		Field Power Wiring
	Terminal Block Connection												
	Marked Terminal												
	Unmarked Terminal												
	Factory Wiring												
	Field Control Wiring												
	Field Power Wiring												

### NOTES (Figs. 3-5)

1. For field power connections, splice field wires to (3) leads from contactor number 1 (FC1).

2.

Control Circuit Wiring	Power Supply Wiring
220 v	380 v, 60 Hz
230 v	230 v, 50 Hz 400 v, 50 Hz
115 v	208/230 v, 60 Hz 460 v, 60 Hz 575 v, 60 Hz

Use 14 AWG copper conductors only for control circuit wiring.

3. Fan motors are terminally protected. Three-phase motors are protected against primary single-phasing conditions.
4. Replacement of original wires must be with type 90 C wire or its equivalent.
5. Factory wiring is in accordance with National Electrical (NEC). Field modifications or additions must be in compliance with all applicable codes.
6. Wiring for field power supply must be rated 60 C. Use copper, copper-clad aluminum or aluminum conductors.

## SAFETY CONSIDERATIONS

Installing, starting up, and servicing air conditioning equipment can be hazardous due to system pressures, electrical components, and equipment location.

Only trained, qualified installers and service mechanics should install, start up, and service this equipment. When working on the equipment, observe precautions in the literature and on tags, stickers, and labels attached to the equipment. Follow all safety codes. Wear safety glasses and work gloves.

	<b>ELECTRIC SHOCK HAZARD</b>
Open all remote disconnects before servicing this equipment.	

## MOTORMASTER® LOW AMBIENT CONTROL

NOTE: Installation of Motormaster Low Ambient Control requires use of fan cycling control accessory, see page 7.

### Introduction

There are two accessory packages as follows:

PACKAGE NO.	UNIT Volts-Ph-Hz	MOTOR Volts-Ph-Hz
50DJ-902---801	208/230-3-60 575-3-60*	200/230-1-60
50DJ-902---811	460-3-60	200/230-1-60

\*For Motormaster head pressure control operation, 575-v unit requires installation of transformer (Carrier Part No. HT01AH854) not included in package.

Each accessory package contains the parts listed in Table 1.

Note that these installation instructions are for 60 Hz units, but installation procedures for 50 Hz units are similar. See price pages for required parts for 50 Hz Motormaster applications. Contact Application Engineering if installation assistance is required.

**Table 1 — Package Contents**

PACKAGE NOS.	50DJ-902---801	50DJ-902---811
<b>Quantity</b>		
1	Speed Control Motor	Speed Control Motor
1	Motor Mount Spacer	Motor Mount Spacer
1	Capacitor	Capacitor
1	Capacitor Boot	Capacitor Boot
1	Motormaster Controller	Motormaster Controller
1	Fastener Package	Fastener Package
1	Instruction Booklet	Instruction Booklet
1	—	Transformer

### Installation

1. Disconnect all power to the unit and open control box.

#### **⚠ WARNING**

To avoid possible electrical shock and personal injury, all power to unit must be disconnected before working on unit. Tag all disconnects to alert others unit is being worked on.

2. Remove FM1 (fan motor no. 1) fan guard (see Fig. 1) located next to control box end.
3. Disconnect FM1 wiring in the motor junction box and remove FM1 from unit.
4. Remove fan propeller from FM1 and save. Fan propeller is reinstalled on the speed control motor in a later step.
5. Place motor mount spacer in place over FM1 motor mount.
6. Install speed control motor with rainshield (included in package) in place of FM1.

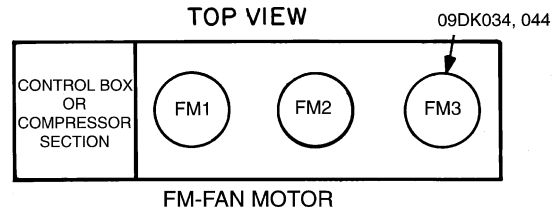

**Fig. 1 — Fan Motor Locations**

7. Because the standard fan motor is 3-phase, and the speed control motor is single-phase, it is necessary to add a capacitor. Install the capacitor on the divider panel above the condenser coil.
8. Mount the capacitor upside down (terminals pointing down) using capacitor strap and screws (holes must be field drilled). See Fig. 2. To prevent capacitor from slipping down, insert an additional screw through the panel for the capacitor to rest on.
9. Disconnect black wire connecting FM1 junction box to TB1 terminal 2 (575-v only). See Fig. 3. Disconnect yellow wire from FC1 terminal 12. Disconnect blue wire from FC1 terminal 13.
10. Connect yellow wire from capacitor to the red wire (T8) in the speed control motor junction box. Use wire nut to connect. See Fig. 4. Connect blue wire from other side of capacitor to the yellow wire (T4) in the speed control motor junction box. Use wire nut to connect.
11. From the same terminal on the capacitor as blue wire connection, run a field-supplied wire to FC1 terminal 12. Tie the blue (T1) and black (T5) wires in the motor junction box together, using a wire nut.
12. Remove the black jumper connecting TB1 1 to TB1 2 in the control box.
13. Mount the Motormaster® controller vertically on the divider panel next to the capacitor. See Fig. 2. It must be mounted vertically with the leads coming out the bottom. Using the template at the back of these instructions, drill the required 4 mounting holes. Use 4 no. 10 sheet metal screws and star washers provided to attach the controller. The star washers must be used to ensure electrical ground.

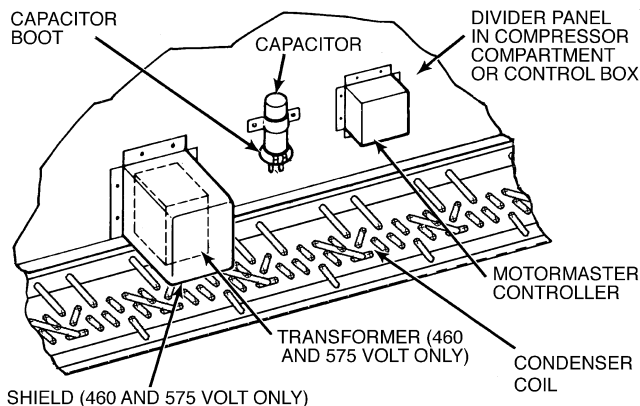

**NOTES:**

1. Transformer shield and 575-v transformer are field supplied (transformer part no. HT01AH854).
2. Exact mounting locations on divider panel for capacitor, Motormaster controller, and transformer are at discretion of installer. There are no wires or obstructions on reverse side of divider panel to interfere with mounting screws.

**Fig. 2 — Mounting Motormaster® Controller, Capacitor, and 575-V or 460-V Transformer**

14. For 208/230-v only:  
Connect a field-supplied wire from TB1 terminal 1 to one of the black wires in the Motormaster controller. Use wire nut to connect. See Fig. 4.
15. Take the black wire that was disconnected in Step 3 and connect it to the purple wire (P1) in the speed control motor junction box. Use wire nut to connect. Replace junction box cover.

**⚠ CAUTION**

Be sure the wires running to the speed control motor are wire-tied securely to the motor mount, to prevent the wires from becoming entangled in the propeller fan when unit is running.

16. For 460-v and 575-v units only, mount and wire transformer (460-v — P/N HT01AH852, 575-v — P/N HT01AH854) as follows:
  - a. Mount transformer to the divider panel. See Fig. 2. Drill required mounting holes.
  - b. Connect field-supplied wire from FC1 terminal 21 to the primary side of the transformer. See Fig. 5. Connect a field-supplied wire from FC1 terminal 22 to the other primary of the transformer.
  - c. Run field-supplied wire from the secondary of the transformer to the capacitor. Run field-supplied wire from the other secondary of the transformer to one of the black wires on the controller. See Fig. 5.
  - d. Install field-supplied shield over the transformer. See Fig. 2.
17. Reinstall the fan propeller and fan guard. Ensure that center of propeller is correct distance from top of fan orifice. See Fig. 5.
18. Route the sensor wire from the controller to the sensor location. Secure sensor wire to avoid contact with condenser coil.

**⚠ CAUTION**

The sensor assembly is fragile. Handle with care.

19. For 09DK020-034 units, secure the sensor to the coil return bend. For 09DK044, secure the sensor to crossover tube. See Fig. 7 for proper location for each unit. Use no. 4-40 screw, two plate washers, and nut provided. See Fig. 8.
20. Coil up excess wire and secure it to controller.
21. Protect sensor wire from physical damage by installing field-supplied protective material.
22. Replace control box cover.

**Winter Start Control** — These compressorless condenser sections do not need to be directly modified. However, the total system may require winter start control. Refer to base unit instructions.

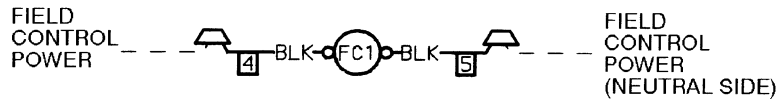
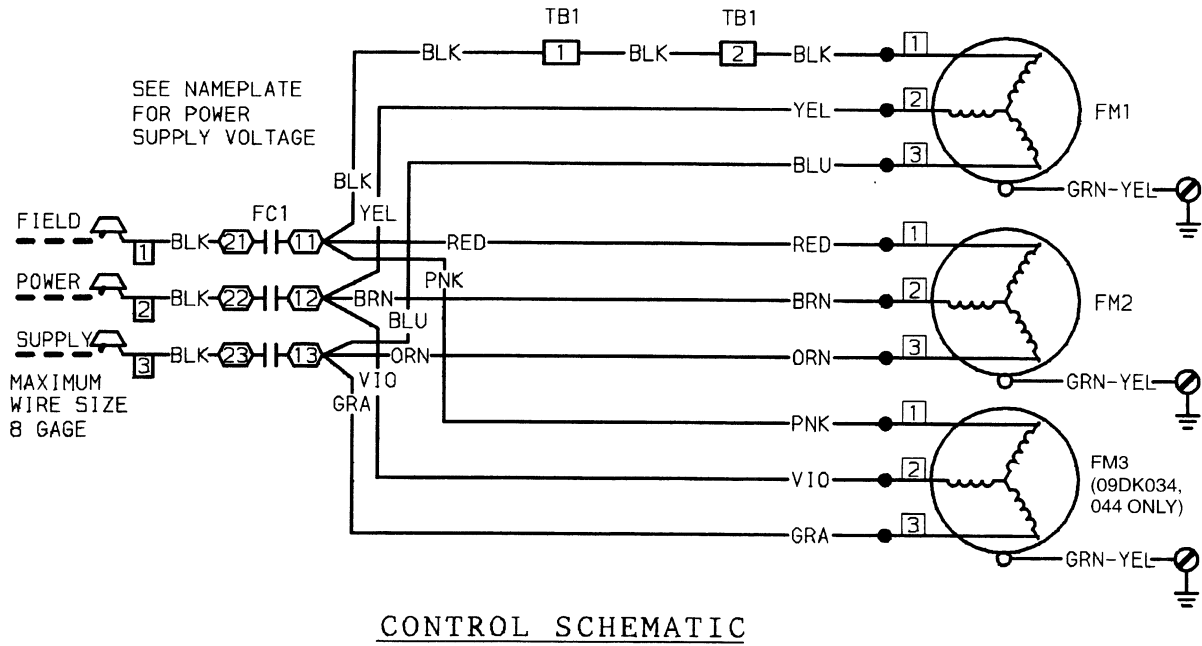

**Fig. 3 — Standard Unit Power and Control Schematic, 09DK**

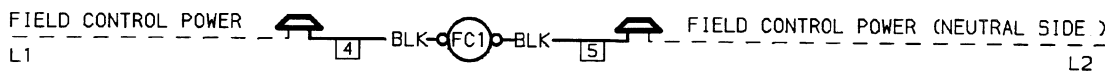
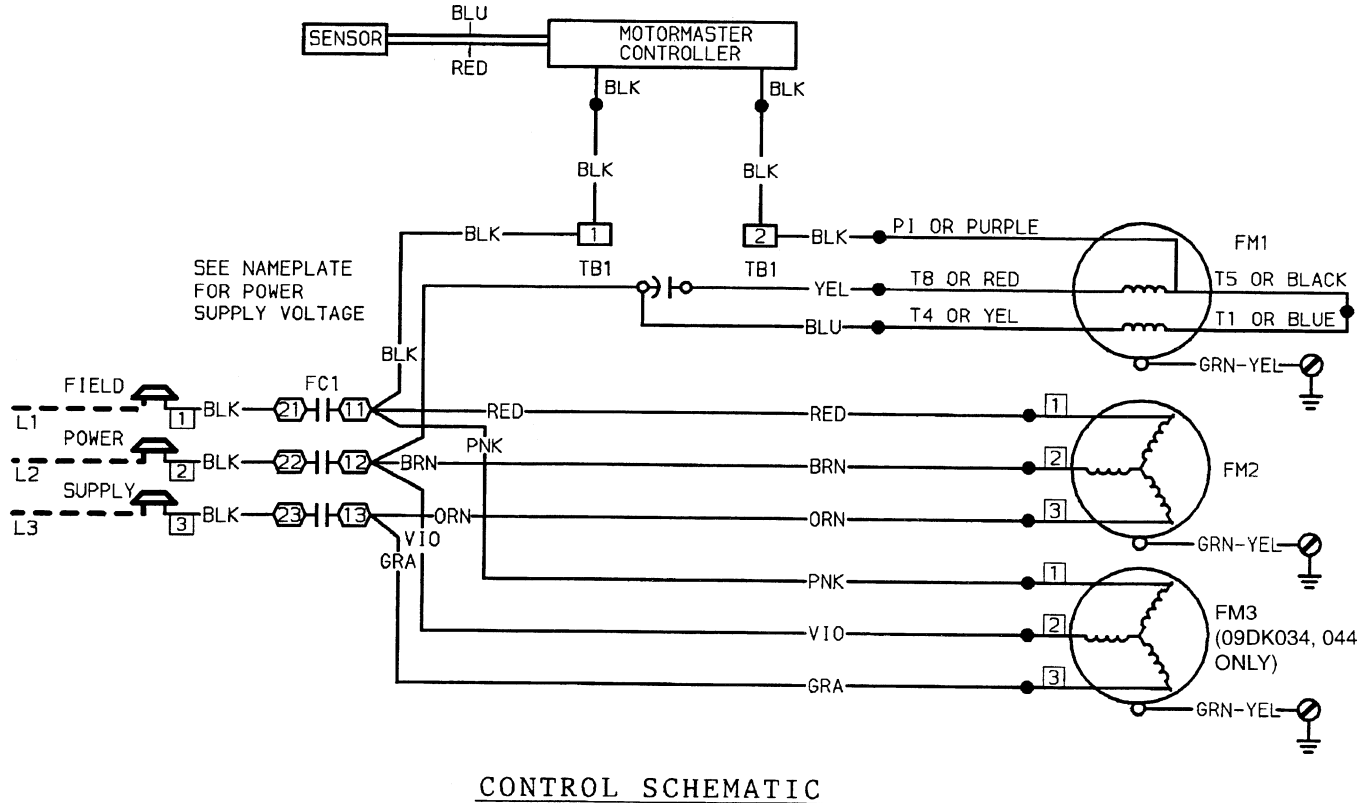

**Fig. 4 — Motormaster® Controller Wiring; 09DK 208/230-Volt Units**

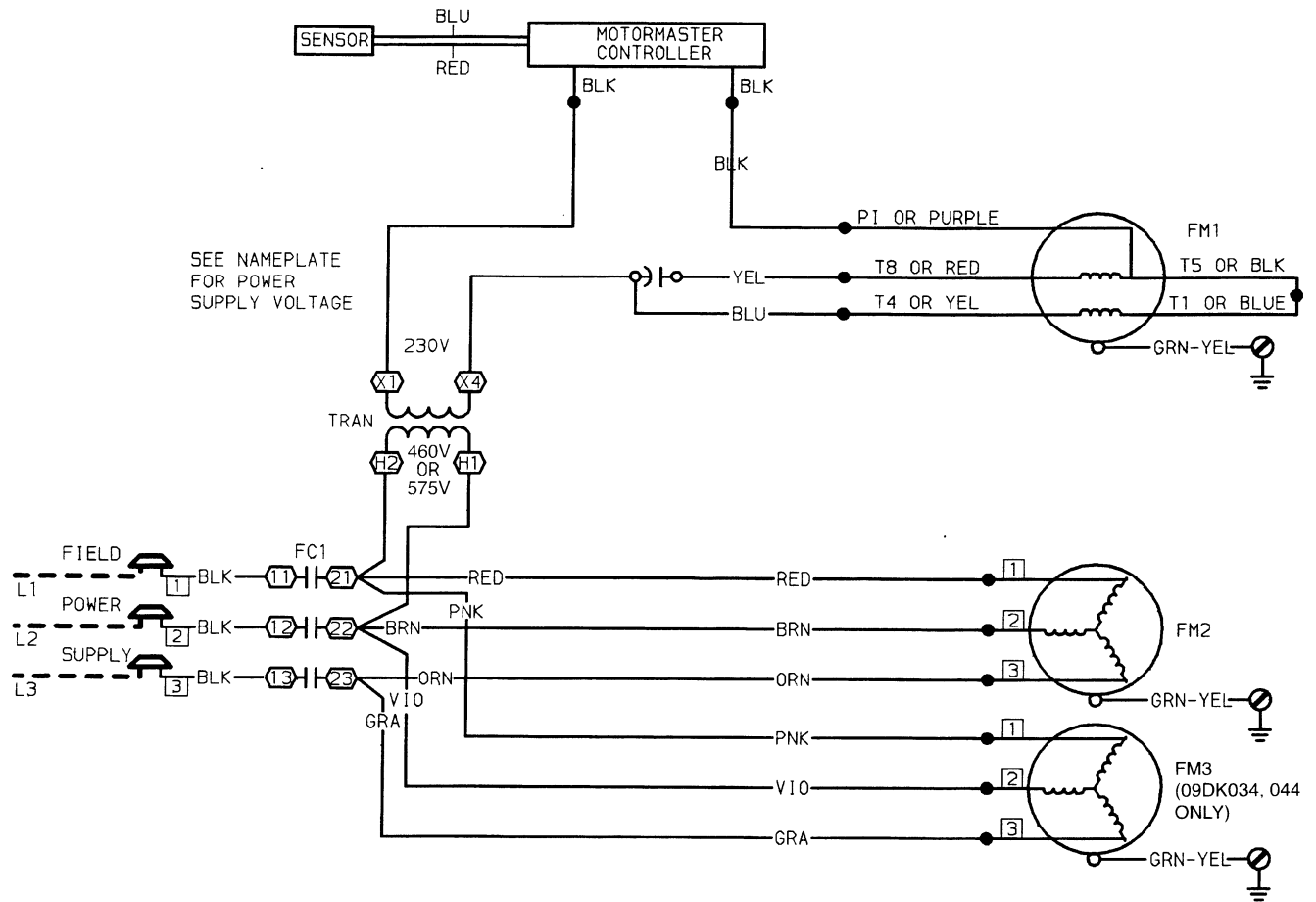

**CONTROL SCHEMATIC**

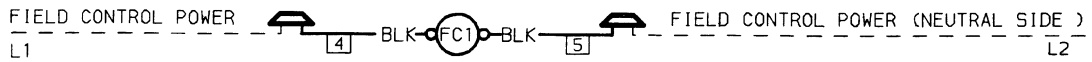

**Fig. 5 — Motormaster® Controller Wiring; 09DK 460-Volt and 575-Volt Units**

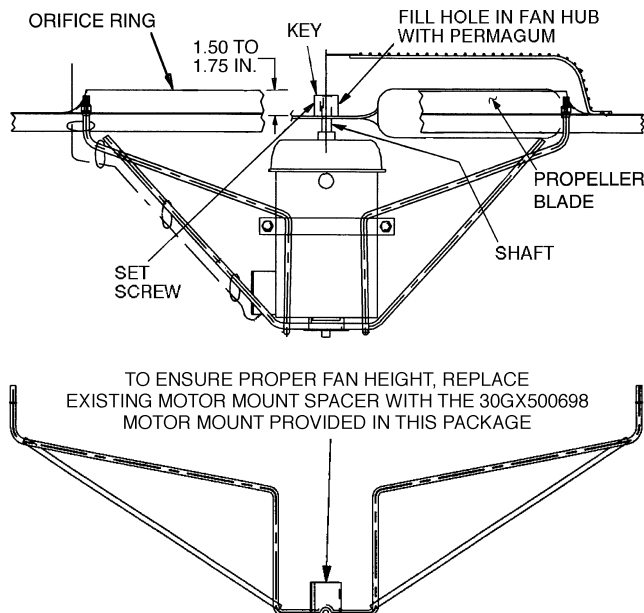

**Fig. 6 — Location of Propeller on Motor Shaft from Outside of Orifice Ring**

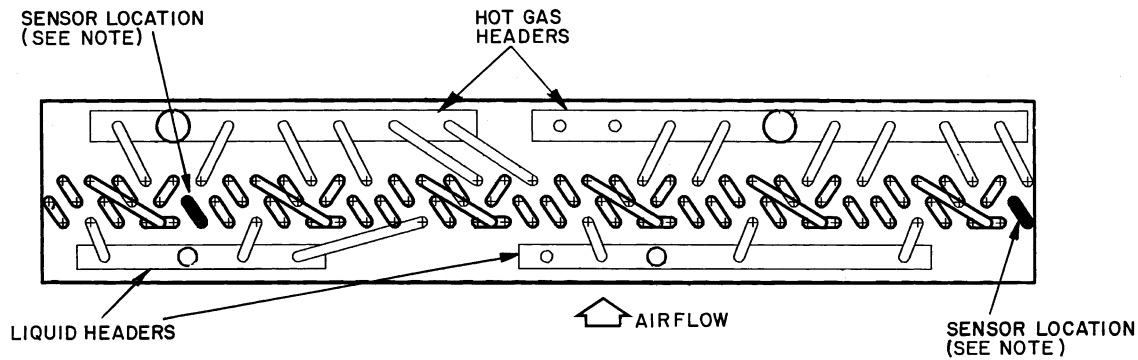

HEADER END 09DK020, 024

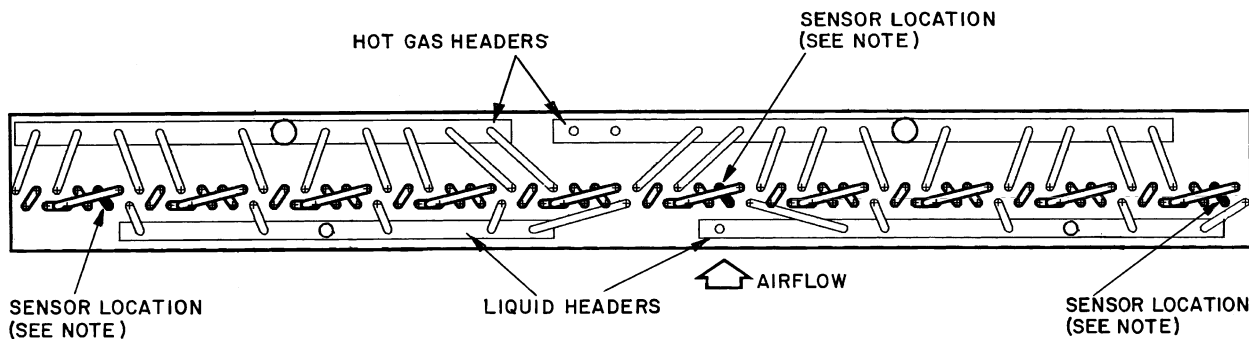

HEADER END 09DK028, 034

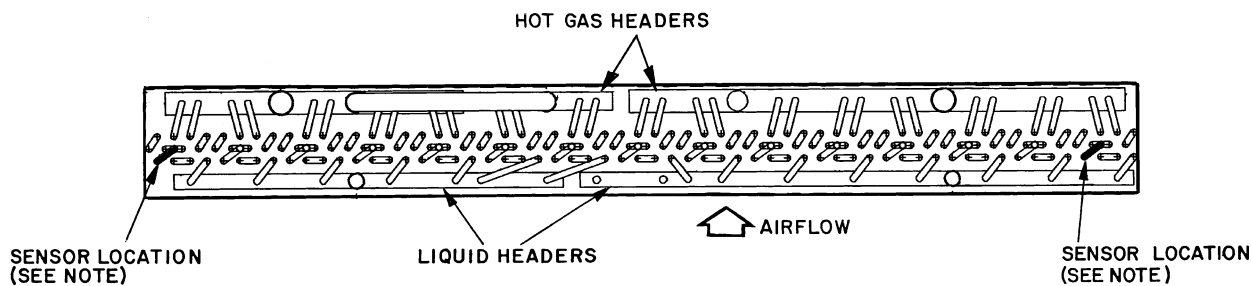

HEADER END 09DK044

NOTE: When using multiple indoor units, or a dual compressor indoor unit, place sensor on circuit containing refrigerant from leading compressor. Only one sensor is required.

Fig. 7 — Motormaster® Sensor Locations on Condenser Coil Header End, 09DK Units

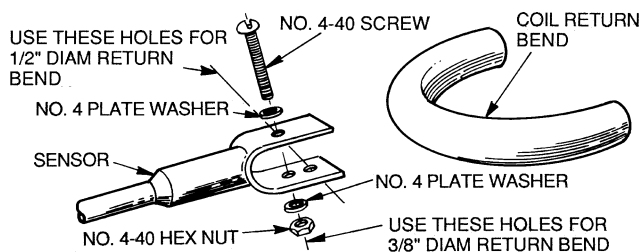

Fig. 8 — Sensor Installation

# ACCESSORY FAN CYCLING CONTROL

## Accessory Fan Cycling Control Usage

PACKAGE NUMBER 09DK	CONTROL CKT VOLTAGE		USED ON 09DK
	3 Ph, 60 Hz	3 Ph, 50 Hz	
500070	208230, 460,575	—	020,024, 028
500071	380	230,400	020 (60 Hz only), 024,028
500072	208230, 460,575	—	034,044
500073	380	230,400	034,044

## Accessory Kit Contents — 09DK

QTY PER KIT NO.				ITEM
070	071	072	073	
1	1	2	2	Temperature Actuated Switch
1	1	1	1	Terminal Block
0	0	1	1	Terminal Adapter
1	1	2	2	Contactor
1	1	1	1	Instructor
1	1	1	1	Parts Bag
PARTS BAG CONTENTS:				
5	5	5	5	Mounting Screws
2	2	4	4	Screws, 8-18 x 1/2-in. long
2	2	4	4	Screws, 6AB x 1/2-in. long
5	5	8	8	Wire Assemblies
3	3	3	3	Wire Ties

**General** — The Accessory Fan Cycling Control maintains unit cooling capacity control during changes in outside ambient temperature. If full cooling is not required during certain operating periods, the accessory can save energy by supplying power to fewer fans.

**Before Installation** — Check kit contents for missing or damaged items. File claim immediately with transit company if anything is missing or damaged. Check to be sure accessory control voltage matches available power supply.

### Fan Cycling Control Installation

1. Shut off power to unit.

#### ▲ WARNING

Electrical shock can cause personal injury or death. Before installing this accessory, be sure power to unit is disconnected. There may be more than one disconnect switch. Attach tags at disconnect(s) to alert others **not** to restore power until installation is completed.

2. Remove unit control box cover. See Fig. 9.
3. *09DK020-028 Units:* Mount temperature actuated switch (ATS) onto the bottom inner divider panel of unit, using two no. 6AB x 1/2-in. long screws provided. Screw holes are predrilled in panel. See Fig. 9.  
*09DK034,044 Units:* Mount temperature actuated switches (ATS and ATS2) onto the bottom inner divider panel of unit, using two no. 6AB x 1/2-in. long screws provided. (2 screws for each switch). Mount switches side by side in predrilled holes. See Fig. 9.

4. *09DK020-028 Units:* Install fan contactor FC2 and terminal block TB2 inside control box. See Fig 10. Disconnect red wire from FC1 (11) and orange wire from FC1 (13). Connect red wire to FC2 (21). Connect orange wire to FC2 (23). Attach 8-in. black wire provided in accessory package to FC1 (11) and FC2 (11). Connect the 8-in. blue wire to FC1 (13) and FC2 (13). Next, connect the 8-in. white wire to FC1 neutral side, and FC2 (C2). Attach the 18-in. black wire to FC1 control power side and TB2 (1). Connect one lead of ATS to TB2 (1) and connect the other lead to FC2 (C1).

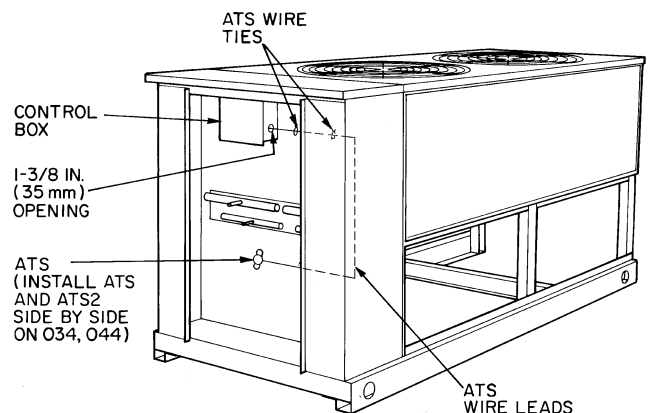

Fig. 9 — Model 09DK (028 Shown)

09DK034,044 Units: Install fan contactors FC2 and FC3 and terminal block TB2 inside control box. See Fig 9. Add terminal adapter to TB2 [1]. See Fig. 10 and 11. Disconnect red and pink wires from FC1 [11]. Also, disconnect orange and gray wires from FC1 [13]. Connect red wire to FC2 [21] and pink wire to FC3 [21]. Also, connect orange wire to FC2 [23] and gray wire to FC3 [23]. Attach 8-in. black wire provided in accessory package to FC1 [11] and FC2 [11]. Connect the other 8-in. black wire to FC1 [11] and FC3 [11]. Connect an 8-in. blue wire to FC1 [13] and FC2 [13]. Attach the other 8-in. blue wire to FC1 [13] and FC3 [13]. Next, connect an 8-in. white wire to FC1 neutral side and FC2 [C2]. Attach the other 8-in. white wire to FC2 [C2] and FC3 [C2]. Connect the 18-in. black wire to FC1 control power side and TB2 [1]. Attach one lead of ATS (Air Temperature Switch) to TB2 [1] and the other lead to FC2 [C1]. Connect one lead of ATS2 to TB2 [1] and the other lead to FC3 [C1]. See Fig. 12 for wiring connections.

5. Route the wire leads of ATS around the coil, keeping them away from the coil and any sharp metal edges. Install wire ties provided through predrilled holes in upper divider panel. See Fig. 9. Run ATS wire leads through wire ties, then into the 1<sup>3</sup>/<sub>8</sub>-in. (35 mm) diameter control box opening.
6. The underside of the ATS is the thermal sensor area that senses the temperature of air entering the coil. The air temperature switch opens at 60 ± 3 F and closes at 70 ± 3 F (020,024,028 units only). On 09DK034 and 09DK044 units, ATS opens at 55 ± 3 F and closes at 65 ± 3 F, and ATS2 opens at 70 ± 3 F and closes at 80 ± 3 F.
7. ATS controls fan motor (FM2). On 09DK034 and 044 units, ATS2 controls fan motor (FM3).

8. If Motormaster® control is to be used to modulate fan motor (FM1), see installation instructions included with 09DK wiring book, and see 32LT Motormaster control installation instructions for additional general reference.

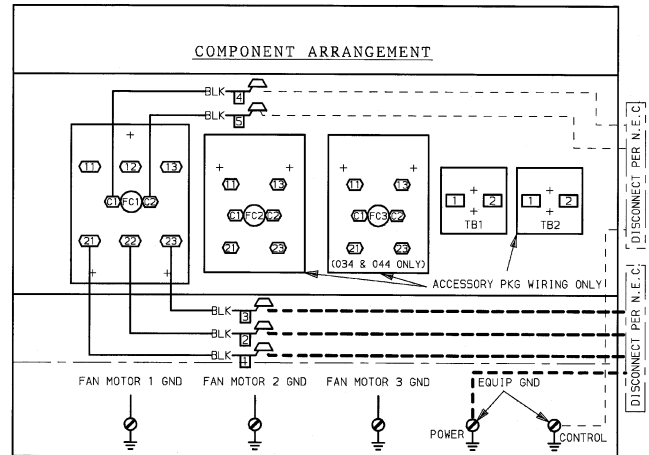

Fig. 10 — Component Arrangement

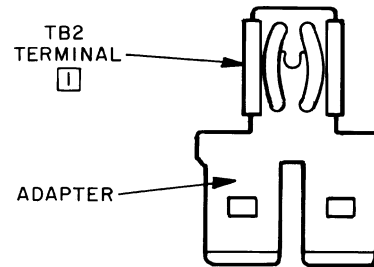
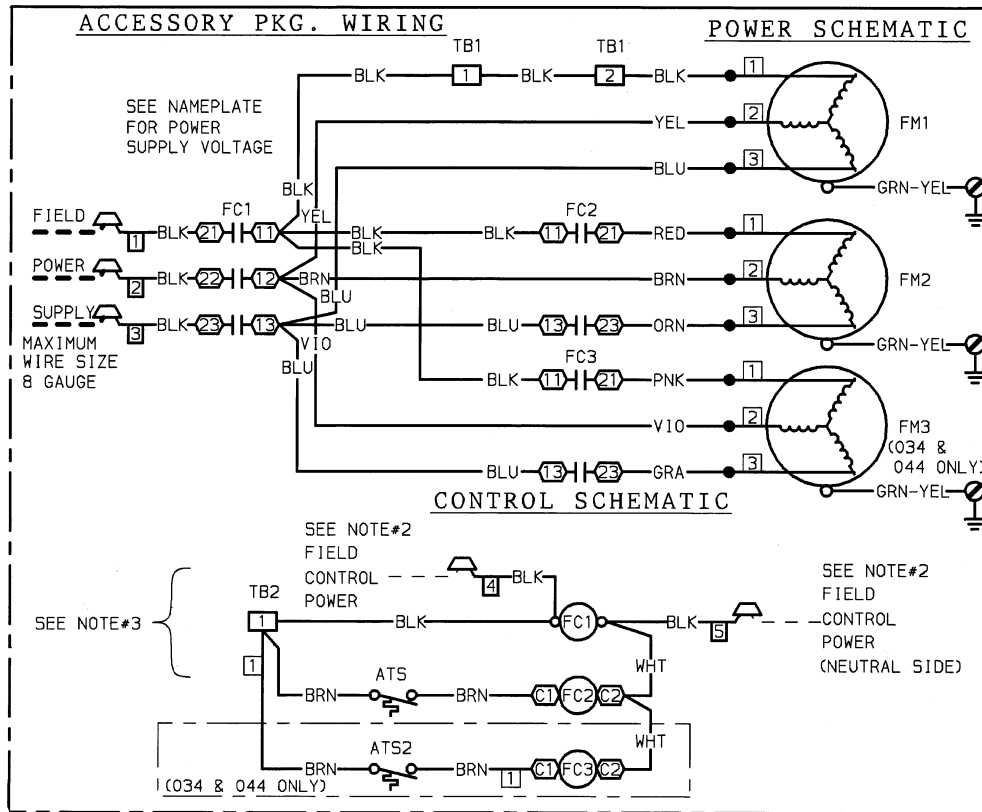

Fig. 11 — Terminal Adapter



**LEGEND**

ATS AIR TEMPERATURE SWITCH EQUIP EQUIPMENT  
 FC FAN CONTACTOR  
 FM FAN MOTOR  
 GND GROUND  
 TB TERMINAL BLOCK

FIELD SPLICE  
 TERMINAL BLOCK CONNECTION  
 MARKED TERMINAL  
 UNMARKED TERMINAL  
 FACTORY WIRE  
 FIELD CONTROL WIRING  
 FIELD POWER WIRING

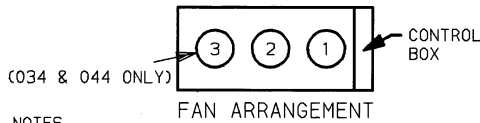

**NOTES:**

1. FOR FIELD POWER CONNECTIONS, SPLICE FIELD WIRES TO (3) LEADS FROM CONTACTOR NUMBER 1 (FC1)
2. CONTROL CIRCUIT WIRING

CONTROL WIRING VOLTAGE	POWER SUPPLY
220V	380V-60HZ
230V	230V-50HZ, 400V-50HZ
115V	208/230V-60HZ, 460V-60HZ, 575-60HZ

FOR FIELD CONTROL CIRCUIT WIRING, USE 14 AWG COPPER CONDUCTORS AND 15 AMP FUSE SIZE ONLY.

3. FOR ACCESSORY PACKAGE WIRING, CONNECT CONTROL CIRCUIT WIRING TO TERMINAL BLOCK 2. TB2 HAS A 15 AMP MAXIMUM OVER CURRENT PROTECTION.

**Fig. 12 — Accessory Fan Cycling Control Wiring**





# MOUNTING TEMPLATE FOR MOTORMASTER® CONTROL

CUT ALONG SOLID BORDER LINES TO REMOVE TEMPLATE

