

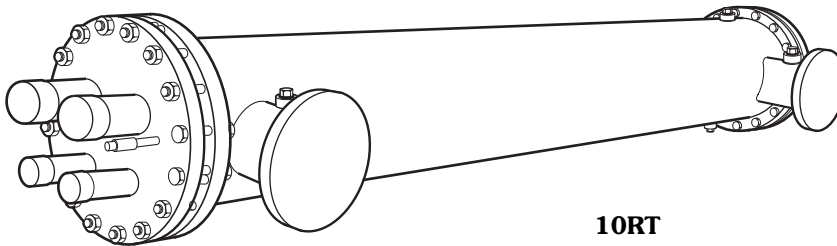

Product Data

10RT Direct-Expansion Liquid Coolers

7¹/₂ to 350 Nominal Tons



Build your system on the best... 10RT Series DX coolers

Choose Carrier 10RT Series direct-expansion (DX) shell-and-tube liquid coolers for built-up systems in office buildings, hospitals, or any commercial applications where unique cooling requirements or space limitations dictate the need for separate location of the cooler from the condenser, compressors, or air-handling components.

Features/Benefits

- Fifteen models, 7¹/₂ through 350 tons normally carried in stock or with short shipping lead times.
- High performance tubes providing more economical cooling.
- Serviceable through-tube design and removable heads.
- Controlled refrigerant velocities for positive oil return and low refrigerant pressure drop.

With 10RT Series coolers, dimensional restrictions are no problem, since you select from a large assortment of shell diameters and lengths. And these compact coolers are available in 7¹/₂ through 350 nominal tons capacity range. (Based on 44 F leaving water temperature; R-22 at 35 F evaporator temperature; 0.0005 fouling factor.)

The 10RT is designed for optimum heat transfer rates and features rolled-in tubes and removable heads. Shell-side baffling is selected for high operating efficiency and minimal fluid pressure drops.

Compliance with ASME (American Society of Mechanical Engineers) codes and quality controlled manufacturing makes the 10RT cooler suitable for a wide variety of trouble-free fluid cooling applications.

Get maximum operating efficiency plus full design and equipment location flexibility. Start with a 10RT, the customized cooler! Customize for low operating costs and maximum efficiency

Series 10RT coolers are designed and built to assure maximum heat transfer at minimal pressure drops, through the use of various custom selection factors. The following customer selection factors govern the relative efficiency of the cooler for a particular application:

Head pass — Proper selection of head pass avoids excessive refrigerant pressure drops and provides sufficiently high refrigerant velocities to assure positive oil return, even under low temperatures or unloaded conditions...2 or 4 passes are available.

Multiple refrigerant circuits — Where required, 10RT coolers can be selected to provide multiple refrigerant circuits, so the cooler will fit virtually any application with a high degree of efficiency, especially at part load. Single circuits are standard on 5- and 6-in. diameter coolers.

On the 8- to 24-in. models, 2 refrigerant circuits are standard. Optional circuiting of up to 4 is available by special order on most shell size diameters. (See page 3 for circuit availability.)

Customized quality in every construction detail

Shells — The shells are made of steel; tubes are $\frac{5}{8}$ -in. OD seamless copper, roller expanded into tube sheets to minimize the possibility of costly refrigerant leakage. Heads are easily removable. All refrigerant connections are steel welded to the heads and bored to ODS copper tubing. The baffles are hot-rolled steel, terne plated for resistance to corrosion, and all exterior surfaces are painted with grey enamel.

Options — Lifting lugs and mounting saddles.

Baffle spacing — Carrier offers 6 different baffle spacing arrangements to control the velocity of fluid circulating within the shell and over the outside of the tubes. Baffle spacing choices are numbered one through 6, with one being the closest baffle spacing (for full cutoff and maximum heat transfer at low flow) and 6 being the widest baffle spacing.

This wide choice of baffle spacings allows selection for optimum heat transfer without exceeding pressure drop limitations.

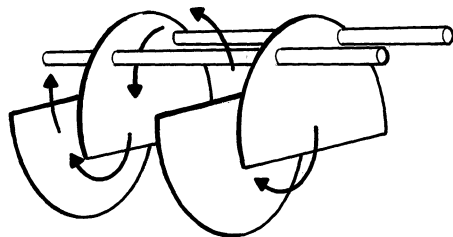

**SHORT CUTOFF —
WIDE SPACING (6)**

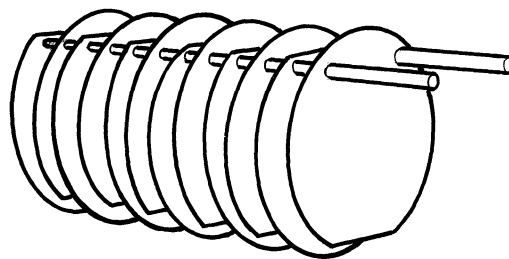

**FULL CUTOFF —
CLOSE SPACING (1)**

Table of contents



	Page
Features/Benefits	1,2
Model Number Nomenclature	3
Physical Data	4,5
Selection Procedure	6,7
Performance Data	8-25
Guide Specifications	26

Model number nomenclature

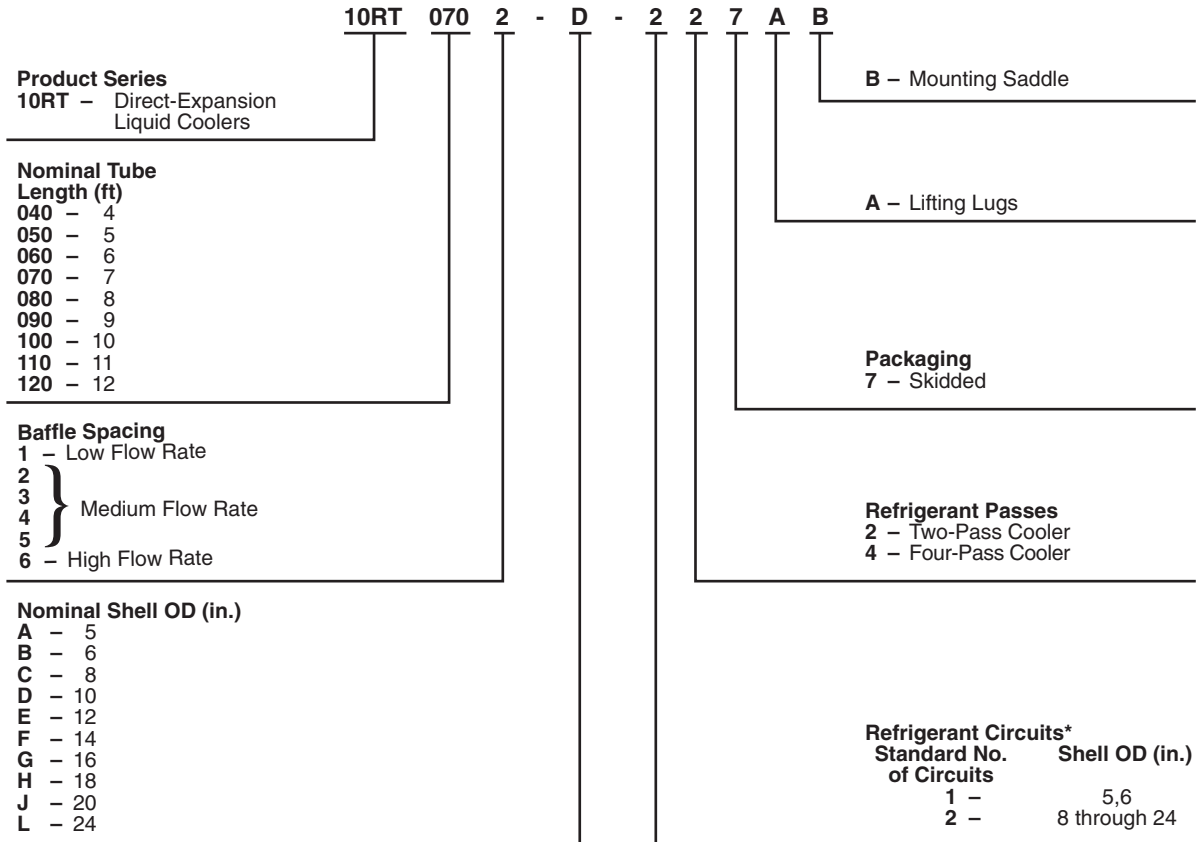

*CIRCUIT AVAILABILITY

LETTER DESIGNATOR	SHELL OD (in.)	NO. OF CIRCUITS			
		1	2	3	4
A	5	Std	NA	NA	NA
B	6	Std	NA	NA	NA
C	8	SO	Std	NA	NA
D	10	SO	Std	SO	NA
E	12	SO	Std	SO	SO
F	14	SO	Std	SO	SO
G	16	SO	Std	SO	SO
H	18	SO	Std	SO	SO
J	20	SO	Std	SO	SO
L	24	SO	Std	SO	SO

LEGEND

NA — Not Available
SO — Special Order
Std — Standard

Physical data

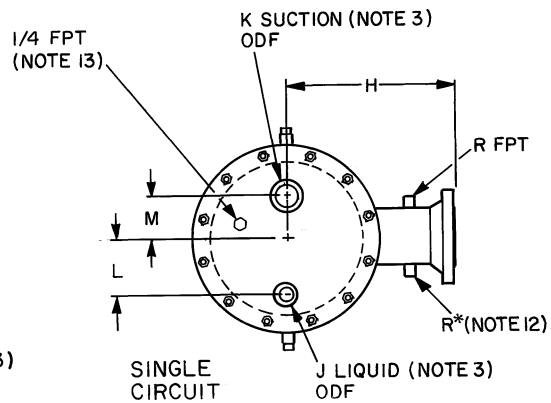
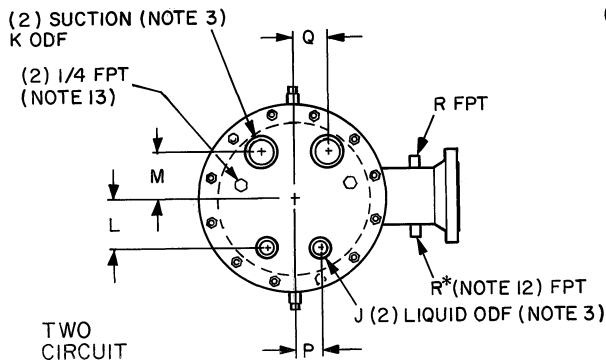
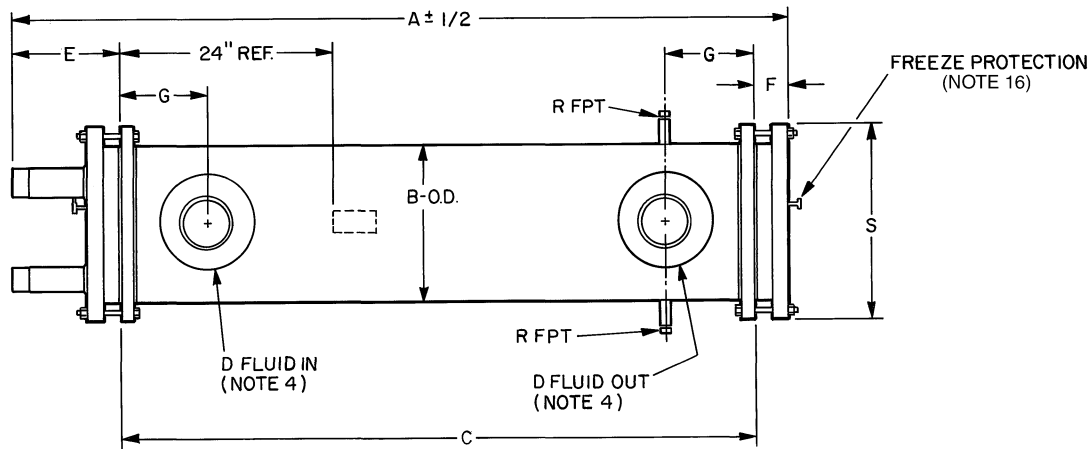

NOTES:

1. Constructed and tested in accordance with ASME code Section VIII for unfired pressure vessels.
2. Maximum working pressures: 200 psi at 100 F tube side; 150 psi at 120 F shell side.
3. Connections J and K are steel welded to head and bored to ODS of copper tubing.
4. Fluid connections are MPT through 3 inches. Connections larger than 3 in. terminate in 150 lb flanges.
5. Shell baffles: hot-rolled steel, terne plate.
6. Heads: ASME specification SA-285, grade C, or cast steel heads, ASME specification SA-216, grade WCA or WCB.
7. Tube sheets: flange quality carbon steel, ASME specification SA-285 grade C.
8. Shell: Steel pipe shell, ASME specification SA-53, grade A or B.
9. Tubes: $\frac{3}{4}$ -in. OD seamless copper tubes per ASME specifications with internal and external enhanced surface.
10. One circuit standard with 5-in. and 6-in. pipe shell (optional for all others). Two circuits standard with 8-in. through 24-in. pipe shells.
11. Insulation: $\frac{3}{4}$ -in. Armaflex standard. Double layer of Armaflex available on special order.
12. Fitting R* used only on 3-in. MPT or smaller fluid connections. Fluid connections larger than 3-in. have both R and R*.
13. External equalizer connection.
14. Add $1\frac{1}{2}$ -in. to dimension B; $\frac{3}{4}$ -in. to dimension F; and $1\frac{1}{2}$ -in. to dimension S to take into account the standard $\frac{3}{4}$ -in. Armaflex insulation.
15. Finish: Grey enamel paint.
16. $\frac{1}{4}$ -in. FPT freeze protection connection.
17. Tube wall thickness: 0.028-in. finned; 0.056-in. plain.



DIMENSIONS — 2 PASS (in.)

UNIT 10RT	A	B	C	D	E	F	G	H	J (ODF)	K (ODF)	L	M	P	Q	R	S
0401-A-127	55 ³ / ₄	5 ⁹ / ₁₆	47 ⁵ / ₈	2	6 ¹³ / ₁₆	1 ⁵ / ₁₆	3 ³ / ₁₆	8 ⁵ / ₈	7 ⁷ / ₈	1 ³ / ₈	1 ¹ / ₄	1 ³ / ₈	—	—	3 ³ / ₄	8 ¹ / ₂
0501-A-127	67 ³ / ₄	5 ⁹ / ₁₆	59 ⁵ / ₈	2	6 ¹³ / ₁₆	1 ⁵ / ₁₆	3 ³ / ₁₆	8 ⁵ / ₈	7 ⁷ / ₈	1 ³ / ₈	1 ¹ / ₄	1 ³ / ₈	—	—	3 ³ / ₄	8 ¹ / ₂
0501-B-127	67 ³ / ₄	6 ⁵ / ₈	59 ⁵ / ₈	2 ¹ / ₂	6 ¹³ / ₁₆	1 ⁵ / ₁₆	3 ⁷ / ₁₆	9 ³ / ₁₆	1 ¹ / ₈	2 ¹ / ₈	1 ⁹ / ₁₆	1 ⁹ / ₁₆	—	—	3 ³ / ₄	9 ³ / ₄
0601-B-127	79 ³ / ₄	6 ⁵ / ₈	71 ⁵ / ₈	2 ¹ / ₂	6 ¹³ / ₁₆	1 ⁵ / ₁₆	3 ⁷ / ₁₆	9 ³ / ₁₆	1 ¹ / ₈	2 ¹ / ₈	1 ⁹ / ₁₆	1 ⁹ / ₁₆	—	—	3 ³ / ₄	9 ³ / ₄
0401-C-227	56	8 ⁵ / ₈	47 ⁵ / ₈	3	6 ¹⁵ / ₁₆	1 ⁷ / ₁₆	3 ⁷ / ₈	10 ³ / ₁₆	1 ³ / ₈	2 ¹ / ₈	2	1 ⁵ / ₈	1 ¹ / ₂	1 ³ / ₄	3 ³ / ₄	11 ³ / ₄
0501-C-227	68	8 ⁵ / ₈	59 ⁵ / ₈	3	6 ¹⁵ / ₁₆	1 ⁷ / ₁₆	3 ⁷ / ₈	10 ³ / ₁₆	1 ³ / ₈	2 ¹ / ₈	2	1 ⁵ / ₈	1 ¹ / ₂	1 ³ / ₄	3 ³ / ₄	11 ³ / ₄
0602-C-227	80	8 ⁵ / ₈	71 ⁵ / ₈	3	6 ¹⁵ / ₁₆	1 ⁷ / ₁₆	3 ⁷ / ₈	10 ³ / ₁₆	1 ³ / ₈	2 ¹ / ₈	2	1 ⁵ / ₈	1 ¹ / ₂	1 ³ / ₄	3 ³ / ₄	11 ³ / ₄
0702-C-227	92	8 ⁵ / ₈	83 ⁵ / ₈	3	6 ¹⁵ / ₁₆	1 ⁷ / ₁₆	3 ⁷ / ₈	10 ³ / ₁₆	1 ³ / ₈	2 ¹ / ₈	2	1 ⁵ / ₈	1 ¹ / ₂	1 ³ / ₄	3 ³ / ₄	11 ³ / ₄
0503-D-227	69	10 ³ / ₄	59 ⁵ / ₈	4	7 ⁷ / ₁₆	1 ¹⁵ / ₁₆	4 ¹ / ₂	11 ⁵ / ₈	1 ³ / ₈	2 ⁵ / ₈	2 ³ / ₄	1 ³ / ₄	2	2 ¹ / ₂	3 ³ / ₄	14 ³ / ₈
0604-D-227	81	10 ³ / ₄	71 ⁵ / ₈	4	7 ⁷ / ₁₆	1 ¹⁵ / ₁₆	4 ¹ / ₂	11 ⁵ / ₈	1 ³ / ₈	2 ⁵ / ₈	2 ³ / ₄	1 ³ / ₄	2	2 ¹ / ₂	3 ³ / ₄	14 ³ / ₈
0702-D-227	93	10 ³ / ₄	83 ⁵ / ₈	4	7 ⁷ / ₁₆	1 ¹⁵ / ₁₆	4 ¹ / ₂	11 ⁵ / ₈	1 ³ / ₈	2 ⁵ / ₈	2 ³ / ₄	1 ³ / ₄	2	2 ¹ / ₂	3 ³ / ₄	14 ³ / ₈
0704-D-227	93	10 ³ / ₄	83 ⁵ / ₈	4	7 ⁷ / ₁₆	1 ¹⁵ / ₁₆	4 ¹ / ₂	11 ⁵ / ₈	1 ³ / ₈	2 ⁵ / ₈	2 ³ / ₄	1 ³ / ₄	2	2 ¹ / ₂	3 ³ / ₄	14 ³ / ₈
0804-D-227	105	10 ³ / ₄	95 ⁵ / ₈	4	7 ⁷ / ₁₆	1 ¹⁵ / ₁₆	4 ¹ / ₂	11 ⁵ / ₈	1 ³ / ₈	2 ⁵ / ₈	2 ³ / ₄	1 ³ / ₄	2	2 ¹ / ₂	3 ³ / ₄	14 ³ / ₈
0904-D-227	117	10 ³ / ₄	107 ⁵ / ₈	5	7 ⁷ / ₁₆	1 ¹⁵ / ₁₆	5 ¹ / ₁₆	11 ⁵ / ₈	1 ³ / ₈	2 ⁵ / ₈	2 ³ / ₄	1 ³ / ₄	2	2 ¹ / ₂	3 ³ / ₄	14 ³ / ₈
0804-E-227	105 ¹ / ₂	12 ³ / ₄	95 ⁵ / ₈	5	7 ¹¹ / ₁₆	2 ³ / ₁₆	5 ³ / ₄	12 ⁵ / ₈	1 ⁵ / ₈	2 ⁵ / ₈	3 ¹ / ₄	1 ³ / ₄	2 ¹ / ₂	2 ³ / ₄	3 ³ / ₄	16 ³ / ₈
0806-E-227	105 ¹ / ₂	12 ³ / ₄	95 ⁵ / ₈	6	7 ¹¹ / ₁₆	2 ³ / ₁₆	5 ³ / ₄	12 ⁵ / ₈	1 ⁵ / ₈	2 ⁵ / ₈	3 ¹ / ₄	1 ³ / ₄	2 ¹ / ₂	2 ³ / ₄	3 ³ / ₄	16 ³ / ₈
1004-F-227	130 ¹ / ₂	14	119 ⁵ / ₈	6	8 ³ / ₁₆	2 ¹¹ / ₁₆	5 ³ / ₄	13 ¹ / ₄	1 ⁵ / ₈	3 ¹ / ₈	3 ³ / ₄	3	2 ⁵ / ₈	2 ⁷ / ₈	3 ³ / ₄	17 ¹ / ₂
1104-F-227	142 ¹ / ₂	14	131 ⁵ / ₈	6	8 ³ / ₁₆	2 ¹¹ / ₁₆	5 ³ / ₄	13 ¹ / ₄	1 ⁵ / ₈	3 ¹ / ₈	3 ³ / ₄	3	2 ⁵ / ₈	2 ⁷ / ₈	3 ³ / ₄	17 ¹ / ₂
1004-G-227	131 ¹ / ₂	16	119 ⁵ / ₈	8	8 ¹¹ / ₁₆	3 ³ / ₁₆	7 ¹ / ₁₆	14 ¹ / ₄	2 ¹ / ₈	3 ¹ / ₈	4	3	3	3 ¹ / ₄	3 ³ / ₄	19 ¹ / ₂
1104-G-227	143 ¹ / ₂	16	131 ⁵ / ₈	8	8 ¹¹ / ₁₆	3 ³ / ₁₆	7 ¹ / ₁₆	14 ¹ / ₄	2 ¹ / ₈	3 ¹ / ₈	4	3	3	3 ¹ / ₄	3 ³ / ₄	19 ¹ / ₂
0903-H-227	119 ¹ / ₂	18	107 ⁵ / ₈	8	8 ¹¹ / ₁₆	3 ³ / ₁₆	7 ¹ / ₁₆	15 ¹ / ₄	2 ¹ / ₈	3 ⁵ / ₈	4 ³ / ₄	3 ¹ / ₂	3 ¹ / ₄	3 ³ / ₄	3 ³ / ₄	21 ¹ / ₂
1003-H-227	131 ¹ / ₂	18	119 ⁵ / ₈	8	8 ¹¹ / ₁₆	3 ³ / ₁₆	7 ¹ / ₁₆	15 ¹ / ₄	2 ¹ / ₈	3 ⁵ / ₈	4 ³ / ₄	3 ¹ / ₂	3 ¹ / ₄	3 ³ / ₄	3 ³ / ₄	21 ¹ / ₂
1205-H-227	155 ¹ / ₂	18	143 ⁵ / ₈	8	8 ¹¹ / ₁₆	3 ³ / ₁₆	7 ¹ / ₁₆	15 ¹ / ₄	2 ¹ / ₈	3 ⁵ / ₈	4 ³ / ₄	3 ¹ / ₂	3 ¹ / ₄	3 ³ / ₄	3 ³ / ₄	21 ¹ / ₂
1003-J-227	132 ¹ / ₂	20	119 ⁵ / ₈	8	9 ³ / ₁₆	3 ¹¹ / ₁₆	8 ³ / ₈	16 ¹ / ₄	2 ¹ / ₈	3 ⁵ / ₈	5	4 ¹ / ₄	3 ¹ / ₂	4 ³ / ₈	3 ³ / ₄	23 ¹ / ₂
1104-J-227	144 ¹ / ₂	20	131 ⁵ / ₈	10	9 ³ / ₁₆	3 ¹¹ / ₁₆	8 ³ / ₈	16 ¹ / ₄	2 ¹ / ₈	3 ⁵ / ₈	5	4 ¹ / ₄	3 ¹ / ₂	4 ³ / ₈	3 ³ / ₄	23 ¹ / ₂
1204-J-227	156 ¹ / ₂	20	143 ⁵ / ₈	10	9 ³ / ₁₆	3 ¹¹ / ₁₆	8 ³ / ₈	16 ¹ / ₄	2 ¹ / ₈	3 ⁵ / ₈	5	4 ¹ / ₄	3 ¹ / ₂	4 ³ / ₈	3 ³ / ₄	23 ¹ / ₂
1206-J-227	155 ¹ / ₂	20	143 ⁵ / ₈	10	8 ¹¹ / ₁₆	3 ¹¹ / ₁₆	8 ³ / ₈	16 ¹ / ₄	2 ¹ / ₈	3 ⁵ / ₈	5	4 ¹ / ₄	3 ¹ / ₂	4 ³ / ₈	3 ³ / ₄	23 ¹ / ₂
0902-L-227	120 ¹ / ₂	24	107 ⁵ / ₈	10	9 ³ / ₁₆	3 ¹¹ / ₁₆	8 ⁹ / ₁₆	18 ¹ / ₄	2 ⁵ / ₈	4 ¹ / ₈	6 ¹ / ₄	3 ⁵ / ₈	4 ³ / ₄	4 ⁷ / ₈	3 ³ / ₄	27 ¹ / ₂
1002-L-227	132 ¹ / ₂	24	119 ⁵ / ₈	10	9 ³ / ₁₆	3 ¹¹ / ₁₆	8 ⁹ / ₁₆	18 ¹ / ₄	2 ⁵ / ₈	4 ¹ / ₈	6 ¹ / ₄	3 ⁵ / ₈	4 ³ / ₄	4 ⁷ / ₈	3 ³ / ₄	27 ¹ / ₂
1103-L-227	144 ¹ / ₂	24	131 ⁵ / ₈	10	9 ³ / ₁₆	3 ¹¹ / ₁₆	8 ⁹ / ₁₆	18 ¹ / ₄	2 ⁵ / ₈	4 ¹ / ₈	6 ¹ / ₄	3 ⁵ / ₈	4 ³ / ₄	4 ⁷ / ₈	3 ³ / ₄	27 ¹ / ₂
1203-L-227	156 ¹ / ₂	24	143 ⁵ / ₈	10	9 ³ / ₁₆	3 ¹¹ / ₁₆	8 ⁹ / ₁₆	18 ¹ / ₄	2 ⁵ / ₈	4 ¹ / ₈	6 ¹ / ₄	3 ⁵ / ₈	4 ³ / ₄	4 ⁷ / ₈	3 ³ / ₄	27 ¹ / ₂

DIMENSIONS — 4 PASS (in.)

UNIT 10RT	A	B	C	D	E	F	G	H	J (ODF)	K (ODF)	L	M	P	Q	R	S
0401-A-147	56 ³ / ₈	5 ⁹ / ₁₆	47 ⁵ / ₈	2	7 ⁷ / ₁₆	1 ⁵ / ₁₆	3 ³ / ₁₆	8 ⁵ / ₈	5 ⁵ / ₈	1 ¹ / ₈	1 ³ / ₄	1 ³ / ₄	—	—	3 ³ / ₄	8 ¹ / ₂
0501-A-147	68 ³ / ₈	5 ⁹ / ₁₆	59 ⁵ / ₈	2	7 ⁷ / ₁₆	1 ⁵ / ₁₆	3 ³ / ₁₆	8 ⁵ / ₈	5 ⁵ / ₈	1 ¹ / ₈	1 ³ / ₄	1 ³ / ₄	—	—	3 ³ / ₄	8 ¹ / ₂
0501-B-147	67 ³ / ₄	6 ⁵ / ₈	59 ⁵ / ₈	2 ¹ / ₂	6 ¹³ / ₁₆	1 ⁵ / ₁₆	3 ⁷ / ₁₆	9 ³ / ₁₆	7 ⁷ / ₈	1 ³ / ₈	2 ¹ / ₈	2 ¹ / ₈	—	—	3 ³ / ₄	9 ³ / ₄
0601-B-147	79 ³ / ₄	6 ⁵ / ₈	71 ⁵ / ₈	2 ¹ / ₂	6 ¹³ / ₁₆	1 ⁵ / ₁₆	3 ⁷ / ₁₆	9 ³ / ₁₆	7 ⁷ / ₈	1 ³ / ₈	2 ¹ / ₈	2 ¹ / ₈	—	—	3 ³ / ₄	9 ³ / ₄
0401-C-247	56 ⁵ / ₈	8 ⁵ / ₈	47 ⁵ / ₈	3	7 ⁹ / ₁₆	1 ⁷ / ₁₆	3 ⁷ / ₈	10 ³ / ₁₆	1 ¹ / ₈	1 ³ / ₈	3	3	1 ²⁵ / ₆₄	1 ²⁵ / ₆₄	3 ³ / ₄	11 ³ / ₄
0501-C-247	68 ⁵ / ₈	8 ⁵ / ₈	59 ⁵ / ₈	3	7 ⁹ / ₁₆	1 ⁷ / ₁₆	3 ⁷ / ₈	10 ³ / ₁₆	1 ¹ / ₈	1 ³ / ₈	3	3	1 ²⁵ / ₆₄	1 ²⁵ / ₆₄	3 ³ / ₄	11 ³ / ₄
0602-C-247	80 ⁵ / ₈	8 ⁵ / ₈	71 ⁵ / ₈	3	7 ⁹ / ₁₆	1 ⁷ / ₁₆	3 ⁷ / ₈	10 ³ / ₁₆	1 ¹ / ₈	1 ³ / ₈	3	3	1 ²⁵ / ₆₄	1 ²⁵ / ₆₄	3 ³ / ₄	11 ³ / ₄
0702-C-247	92 ⁵ / ₈	8 ⁵ / ₈	83 ⁵ / ₈	3	7 ⁹ / ₁₆	1 ⁷ / ₁₆	3 ⁷ / ₈	10 ³ / ₁₆	1 ¹ / ₈	1 ³ / ₈	3	3	1 ²⁵ / ₆₄	1 ²⁵ / ₆₄	3 ³ / ₄	11 ³ / ₄
0503-D-247	69	10 ³ / ₄	59 ⁵ / ₈	4	7 ⁷ / ₁₆	1 ¹⁵ / ₁₆	4 ¹ / ₂	11 ⁵ / ₈	1 ¹ / ₈	2 ¹ / ₈	4 ¹ / ₁₆	3	1 ¹ / ₈	2	3 ³ / ₄	14 ³ / ₈
0604-D-247	81	10 ³ / ₄	71 ⁵ / ₈	4	7 ⁷ / ₁₆	1 ¹⁵ / ₁₆	4 ¹ / ₂	11 ⁵ / ₈	1 ¹ / ₈	2 ¹ / ₈	4 ¹ / ₁₆	3	1 ¹ / ₈	2	3 ³ / ₄	14 ³ / ₈
0702-D-247	93	10 ³ / ₄	83 ⁵ / ₈	4	7 ⁷ / ₁₆	1 ¹⁵ / ₁₆	4 ¹ / ₂	11 ⁵ / ₈	1 ¹ / ₈	2 ¹ / ₈	4 ¹ / ₁₆	3	1 ¹ / ₈	2	3 ³ / ₄	14 ³ / ₈
0704-D-247	93	10														

Selection procedure — water ratings (with example)



I Determine job requirements.

Given:

Cooling Load 70 Ton
 Leaving Chilled Water Temperature (LCWT) 44 F
 Chilled Water Temperature Rise/Range (tw) 10 F
 Saturated Evaporator Temperature (SET.) 36 F
 Refrigerant R-22
 Refrigerant Circuits Required 2
 Fouling Factor 0.0005

II Determine leaving temperature difference (LTD).

LTD = LCWT – SET.
 = 44 – 36
 = 8 F

III Determine cooler size and number of passes.

Enter capacity tables for R-22, 10 F rise and 8 F LTD.
 Read down the column until a capacity is found equal to or greater than the required 70 ton. A 10RT0804-E has a capacity of 79.5 ton and is a 2-pass arrangement.

IV Determine system balance.

Draw a system line for the 10RT0804-E and a system line for the compressor to determine the actual capacity at the balance point. Assume a 6 Series, semi-hermetic compressor has been selected.

A. System line for 10RT0804-E.

Make sure the points plotted are for a given pass arrangement. The leaving chilled water temperature and chilled water temperature rise remains constant. The evaporator temperature varies.

*SET (F)	35	36	37
LCWT (F)	44	44	44
tw (F)	10	10	10
LTD (F)	9	8	7
*Cap. (Ton)	98.23	79.5	60.68

*Plot on system balance graph.

B. System line for 5H compressor.

From inspection of the rating tables in the current Product Data Digest, the 5H66 is the suitable match for the 10RT. Let SCT = 105 F.

SST* = 30 F; Cap. = 65.7 Ton

SST* = 40 F; Cap. = 81.3 Ton

*Saturated suction temperature.

When plotting compressor, take into account the line losses. Assume 2 F line loss.

C. Balance point capacity.

Where the 2 lines intersect is the balance capacity.

Cap. = 72.8 Ton

SET. = 36.2 F

SST = 34.2 F

V Determine actual gpm and pressure drop.

A. Determine gpm.

GPM = Balanced Capacity x 2.4 gpm/ton
 = 72.8 x 2.4
 = 175 gpm

B. Determine pressure drop.

Pressure drop for 175 gpm can be found by interpolation.

$$\frac{(72.8 - 60.68)(4.79 - 2.83)}{(79.5 - 60.68)} + 2.83$$

= 4.1 psi (9.4 ft water)

VI Final cooler selection, compressor selection, and balance capacity.

A. Cooler: 10RT0804-E-227

length = 8 ft

diameter = 12 in.

baffle spacing = number 4

refrigerant circuits = 2

refrigerant passes = 2

B. Compressor: 5H66

C. Balance conditions: Cap. = 72.8 ton at 36.2 F SET.

GPM = 175

Pressure Drop = 4.1 psi

(9.4 ft water)

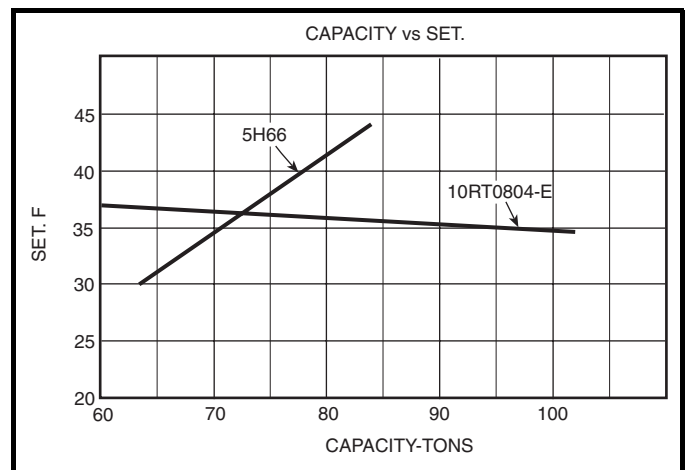

Selection procedure — brine ratings



The procedure is basically the same as for water. The difference is in the charts. The brine charts are based on specific saturated evaporator temperatures (SET) and percent ethylene or propylene glycol. The charts for water are based on 35 F SET only.

Performance data



WATER RATINGS — R-22 6 F WATER TEMPERATURE RANGE; 4 GPM/TON

UNIT 10RT	LEAVING TEMPERATURE DIFFERENCE (LTD) (F)															
	5		6		7		8		9		10		11		12	
	Cap.	PD	Cap.	PD	Cap.	PD	Cap.	PD	Cap.	PD	Cap.	PD	Cap.	PD	Cap.	PD
0401-A	—	—	—	—	2.69	1.05	4.09	2.18	5.37	3.74	6.66	5.69	8.19	8.59	6.33	5.18
0501-A	2.24	0.99	3.67	2.23	5.12	4.32	6.58	7.08	8.17	10.89	6.52	7.08	8.20	10.89	—	—
0501-B	3.18	0.92	5.11	1.80	7.63	4.07	9.86	6.79	12.08	10.06	9.52	6.38	12.11	10.07	—	—
0601-B	5.63	2.79	8.17	5.87	10.51	9.67	7.79	5.33	10.90	10.37	—	—	—	—	—	—
0401-C	—	—	—	—	8.03	1.18	11.76	2.56	15.11	4.20	18.85	6.42	14.18	3.71	18.81	6.42
0501-C	6.59	1.09	10.24	2.40	14.42	4.81	18.54	7.85	13.24	4.05	18.05	7.38	—	—	—	—
0602-C	9.49	1.29	13.86	2.77	18.17	4.81	21.84	6.85	19.02	5.21	26.14	9.71	—	—	—	—
0702-C	13.65	3.12	17.62	5.14	21.42	7.59	21.40	7.59	—	—	—	—	—	—	—	—
0503-D	—	—	—	—	18.61	1.34	24.34	2.27	30.78	3.66	36.40	5.07	31.66	3.90	39.27	5.84
0604-D	—	—	16.99	0.96	23.71	1.52	29.52	2.32	35.26	3.28	31.87	2.69	42.97	4.91	—	—
0702-D	20.02	2.85	26.69	5.08	32.63	7.62	31.92	7.32	42.59	12.70	—	—	—	—	—	—
0704-D	16.67	1.01	23.34	1.69	29.40	2.66	26.61	2.21	37.26	4.30	—	—	—	—	—	—
0804-D	21.48	1.64	27.66	2.68	27.47	2.69	38.34	5.15	—	—	—	—	—	—	—	—
0904-D	25.06	2.70	25.84	2.89	37.99	6.16	50.16	10.53	62.38	15.91	—	—	—	—	—	—
0804-E	33.82	2.45	43.22	3.94	42.08	3.74	60.61	7.69	—	—	—	—	—	—	—	—
0806-E	26.99	1.30	37.34	2.38	45.78	3.44	46.94	3.61	65.56	6.76	84.26	10.82	102.82	15.66	—	—
1004-F	47.06	2.64	58.71	4.07	73.76	6.29	90.98	9.57	106.21	12.81	—	—	—	—	—	—
1104-F	52.60	3.74	70.01	6.55	86.25	9.76	102.57	13.60	—	—	—	—	—	—	—	—
1004-G	58.90	2.44	68.31	3.26	87.40	5.26	109.41	8.27	128.83	11.26	150.88	15.44	—	—	—	—
1104-G	61.88	3.16	82.55	5.54	103.33	8.56	124.27	12.20	147.95	17.38	—	—	—	—	—	—
0903-H	74.18	2.72	88.38	3.79	97.48	4.64	119.33	6.81	144.68	9.94	—	—	—	—	—	—
1003-H	80.75	3.71	93.28	4.96	117.17	7.66	144.82	11.65	—	—	—	—	—	—	—	—
1206-H	83.38	1.82	113.41	3.35	143.59	5.32	171.52	7.50	—	—	—	—	—	—	—	—
1003-J	100.08	3.30	116.03	4.41	150.12	7.35	180.40	10.36	—	—	—	—	—	—	—	—
1104-J	101.36	2.41	133.70	4.10	170.94	6.69	203.91	9.32	241.33	13.01	—	—	—	—	—	—
1204-J	120.62	4.04	158.17	6.88	193.50	10.10	233.48	14.73	—	—	—	—	—	—	—	—

8 F WATER TEMPERATURE RANGE; 3 GPM/TON

UNIT 10RT	LEAVING TEMPERATURE DIFFERENCE (LTD) (F)															
	5		6		7		8		9		10		11		12	
	Cap.	PD	Cap.	PD	Cap.	PD	Cap.	PD	Cap.	PD	Cap.	PD	Cap.	PD	Cap.	PD
0401-A	—	—	2.20	0.71	3.31	0.97	4.71	1.63	6.00	2.63	7.55	4.20	8.83	5.69	10.10	7.36
0501-A	2.87	0.95	4.48	1.88	6.11	3.50	7.57	5.34	8.99	7.52	7.39	5.06	9.78	8.89	11.51	11.97
0501-B	4.15	0.90	6.38	1.58	8.89	3.12	11.14	4.88	13.33	7.01	15.24	9.07	14.01	7.67	—	—
0601-B	7.02	2.42	9.70	4.68	12.02	7.22	13.97	9.67	13.22	8.66	—	—	—	—	—	—
0401-C	—	—	6.61	0.77	9.90	1.09	13.65	1.94	17.41	3.17	20.78	4.45	24.47	6.12	27.43	7.54
0501-C	8.97	1.11	13.14	2.26	16.86	3.68	20.97	5.72	24.50	7.73	21.66	6.03	27.63	9.63	—	—
0602-C	12.01	1.18	16.09	2.09	20.38	3.39	17.44	2.49	23.33	4.45	30.48	7.52	—	—	—	—
0702-C	16.24	2.48	20.12	3.80	18.87	3.34	25.77	6.21	34.12	10.77	—	—	—	—	—	—
0503-D	—	—	14.92	0.79	20.61	1.03	27.10	1.59	33.53	2.45	38.44	3.19	35.47	2.74	44.69	4.35
0604-D	13.05	0.66	19.29	0.84	26.00	1.10	31.75	1.52	27.20	1.12	36.30	1.99	47.49	3.40	56.77	4.79
0702-D	24.01	2.31	30.53	3.78	27.95	3.16	38.63	6.04	50.45	10.18	61.29	14.68	—	—	—	—
0704-D	19.94	0.92	26.55	1.25	31.99	1.79	31.86	1.80	42.56	3.17	53.36	4.94	—	—	—	—
0804-D	25.17	1.29	30.61	1.88	33.56	2.27	45.77	4.18	57.97	6.66	—	—	—	—	—	—
0904-D	28.13	1.92	31.27	2.35	44.97	4.86	58.59	8.25	69.47	11.24	82.68	15.92	—	—	—	—
0804-E	38.67	1.80	47.06	2.62	51.44	3.16	70.18	5.80	88.81	9.16	—	—	—	—	—	—
0806-E	30.55	1.06	40.82	1.66	48.21	2.22	53.85	2.74	70.53	4.50	89.37	7.00	108.16	10.01	126.64	13.45
1004-F	52.75	1.90	67.80	3.05	85.26	4.79	100.46	6.54	117.73	8.98	132.80	11.30	147.73	13.87	—	—
1104-F	63.66	3.10	80.11	4.79	98.73	7.29	115.03	9.76	130.97	12.58	—	—	—	—	—	—
1004-G	62.42	1.57	82.98	2.75	102.34	4.10	121.73	5.71	143.91	7.99	165.93	10.63	185.09	13.09	—	—
1104-G	76.24	2.72	98.76	4.51	119.65	6.52	140.64	8.89	161.51	11.62	181.96	14.68	—	—	—	—
0903-H	83.38	1.92	89.38	2.22	114.53	3.62	136.62	5.04	162.15	7.05	187.84	9.37	213.58	12.01	—	—
1003-H	84.43	2.30	112.03	4.04	136.20	5.84	164.03	8.43	191.93	11.46	—	—	—	—	—	—
1206-H	100.05	1.49	132.36	2.60	160.71	3.75	189.06	5.12	216.50	6.70	—	—	—	—	—	—
1003-J	104.93	2.05	139.37	3.59	173.80	5.55	208.49	7.92	243.33	10.69	—	—	—	—	—	—
1104-J	123.80	2.03	159.11	3.29	196.59	5.00	234.05	7.06	267.16	9.04	303.48	11.71	—	—	—	—
1204-J	145.33	3.29	185.85	5.37	221.35	7.48	261.01	10.45	295.33	13.29	—	—	—	—	—	—

LEGEND

- Cap. — Capacity (Tons)
- EFT — Entering Fluid Temperature
- LFT — Leaving Fluid Temperature
- PD — Pressure Drop (PSIG)
- SET — Refrigerant Saturated Evaporator Temperature

NOTES:

1. Ratings based on 35 F saturated evaporator temperature. Fouling factor is 0.0005.
2. Shaded selections are 2-pass. All other selections are 4-pass.
3. LTD = LFT – SET
4. Range = EFT – LFT



WATER RATINGS — R-22 (cont)
10 F WATER TEMPERATURE RANGE; 2.4 GPM/TON

UNIT 10RT	LEAVING TEMPERATURE DIFFERENCE (LTD) (F)															
	5		6		7		8		9		10		11		12	
	Cap.	PD	Cap.	PD	Cap.	PD	Cap.	PD	Cap.	PD	Cap.	PD	Cap.	PD	Cap.	PD
0401-A	—	—	2.53	0.68	3.79	0.90	5.06	1.19	6.62	2.05	7.92	2.92	9.43	4.21	10.69	5.38
0501-A	3.66	0.98	5.12	1.55	6.74	2.71	8.19	3.99	9.61	5.53	8.61	4.41	10.67	6.75	13.09	10.07
0501-B	5.10	0.89	7.61	1.46	9.86	2.45	12.09	3.68	14.06	4.95	12.73	4.09	15.90	6.38	19.11	9.07
0601-B	8.50	2.31	10.85	3.76	13.15	5.56	11.68	4.33	15.52	7.71	19.37	11.86	—	—	—	—
0401-C	—	—	8.02	0.75	11.35	0.99	15.12	1.51	18.90	2.37	22.60	3.43	25.90	4.45	24.46	4.00
0501-C	10.80	1.07	15.01	1.87	19.16	3.08	22.78	4.36	20.35	3.49	26.26	5.78	31.26	7.95	—	—
0602-C	13.87	1.08	18.18	1.73	21.88	2.49	20.41	2.17	27.60	4.02	33.58	5.84	40.82	8.51	—	—
0702-C	18.01	1.94	21.85	2.87	23.12	3.22	30.80	5.74	37.80	8.43	—	—	—	—	—	—
0503-D	—	—	16.84	0.73	23.31	0.94	29.00	1.16	34.66	1.66	40.26	2.25	39.20	2.15	48.52	3.30
0604-D	14.79	0.63	21.51	0.77	27.27	0.93	32.97	1.11	29.59	1.00	40.68	1.61	49.98	2.40	61.27	3.60
0702-D	26.75	1.83	33.18	2.86	34.48	3.10	45.27	5.32	56.07	8.04	69.00	12.11	—	—	—	—
0704-D	22.01	0.83	28.06	1.02	33.94	1.30	34.77	1.36	47.78	2.58	58.67	3.84	69.47	5.33	—	—
0804-D	26.91	1.05	27.45	1.08	38.27	1.88	51.82	3.45	64.08	5.25	73.81	6.80	—	—	—	—
0904-D	25.92	1.13	38.07	2.25	51.82	4.16	64.10	6.30	76.11	8.81	86.81	11.25	—	—	—	—
0804-E	42.18	1.39	42.11	1.39	60.68	2.83	79.50	4.79	98.23	7.25	116.66	10.10	—	—	—	—
0806-E	33.85	0.96	42.26	1.16	42.22	1.16	60.64	2.28	79.26	3.75	97.97	5.57	116.58	7.71	131.45	9.54
1004-F	60.30	1.58	76.67	2.51	94.19	3.76	111.47	5.26	126.53	6.69	141.56	8.29	—	—	—	—
1104-F	73.24	2.64	90.89	4.00	108.40	5.65	124.48	7.38	140.41	9.34	—	—	—	—	—	—
1004-G	72.22	1.34	94.51	2.29	114.16	3.26	136.30	4.65	155.68	6.00	175.06	7.51	196.72	9.53	—	—
1104-G	90.28	2.46	111.46	3.67	132.49	5.11	155.99	7.15	176.56	9.10	—	—	—	—	—	—
0903-H	91.50	1.50	102.53	1.86	128.10	2.87	153.67	4.10	179.25	5.54	204.80	7.19	230.36	9.04	255.79	11.09
1003-H	100.66	2.11	126.90	3.29	154.87	4.86	182.60	6.74	210.23	8.90	234.70	10.92	—	—	—	—
1206-H	116.28	1.30	144.65	1.97	176.80	2.94	204.85	3.91	232.47	5.01	—	—	—	—	—	—
1003-J	127.35	1.96	162.22	3.13	197.05	4.58	231.65	6.29	266.21	8.26	300.60	10.49	—	—	—	—
1104-J	145.77	1.81	183.80	2.84	221.27	4.10	254.15	5.32	290.95	6.99	—	—	—	—	—	—
1204-J	171.88	2.99	207.67	4.27	247.43	6.09	282.29	7.85	—	—	—	—	—	—	—	—

12 F WATER TEMPERATURE RANGE; 2 GPM/TON

UNIT 10RT	LEAVING TEMPERATURE DIFFERENCE (LTD) (F)															
	5		6		7		8		9		10		11		12	
	Cap.	PD	Cap.	PD	Cap.	PD	Cap.	PD	Cap.	PD	Cap.	PD	Cap.	PD	Cap.	PD
0401-A	—	—	2.99	0.68	4.12	0.82	5.66	1.11	6.95	1.57	8.49	2.37	9.78	3.12	11.05	3.99
0501-A	4.09	0.91	5.71	1.36	7.33	2.24	8.63	3.06	7.40	2.25	9.81	4.01	12.21	6.26	13.96	7.96
0501-B	5.75	0.84	8.27	1.20	10.77	2.04	12.77	2.84	11.40	2.30	14.04	3.44	17.76	5.58	20.45	7.23
0601-B	9.30	1.91	11.66	3.00	13.97	4.33	13.93	4.33	17.14	6.49	21.00	9.68	24.88	13.44	—	—
0401-C	6.13	0.61	9.41	0.74	13.14	0.97	16.89	1.33	20.65	1.99	24.36	2.79	27.32	3.48	26.47	3.25
0501-C	12.56	1.04	16.76	1.63	20.47	2.41	24.56	3.52	23.88	3.36	28.83	4.82	35.82	7.38	40.93	9.36
0602-C	15.32	1.00	19.64	1.40	23.35	1.97	23.34	1.97	30.57	3.41	37.77	5.21	43.82	6.85	52.18	9.71
0702-C	19.71	1.62	18.90	1.48	27.29	3.15	34.30	4.93	41.31	7.03	49.66	10.09	—	—	—	—
0503-D	13.03	0.60	18.66	0.70	24.35	0.84	30.78	1.04	36.44	1.28	33.60	1.14	41.29	1.64	52.26	2.66
0604-D	16.43	0.61	22.67	0.71	28.44	0.82	34.16	0.96	33.90	0.96	43.06	1.25	54.25	1.99	63.65	2.70
0702-D	29.34	1.54	27.94	1.41	38.65	2.68	50.62	4.62	61.44	6.75	74.32	9.84	85.14	12.71	—	—
0704-D	23.93	0.77	29.97	0.92	29.26	0.90	39.87	1.26	50.63	2.00	63.66	3.18	74.50	4.32	85.20	5.60
0804-D	29.10	0.95	30.66	1.00	42.83	1.64	55.11	2.70	67.43	4.02	79.58	5.60	91.51	7.36	—	—
0904-D	31.01	1.13	43.21	2.03	55.54	3.30	69.24	5.13	81.35	7.06	—	—	—	—	—	—
0804-E	45.56	1.14	47.05	1.20	65.75	2.30	84.61	3.76	105.37	5.82	122.10	7.70	140.47	10.10	—	—
0806-E	35.17	0.85	44.46	1.04	46.84	1.09	65.26	1.87	79.96	2.68	98.69	3.97	117.42	5.49	136.07	7.25
1004-F	67.48	1.39	85.01	2.18	100.44	2.96	118.00	4.07	135.16	5.35	—	—	—	—	—	—
1104-F	79.87	2.18	98.80	3.31	115.40	4.42	133.77	5.98	—	—	—	—	—	—	—	—
1004-G	83.08	1.25	102.65	1.86	125.18	2.75	147.57	3.81	167.05	4.82	188.92	6.19	—	—	—	—
1104-G	99.04	2.05	123.37	3.16	144.68	4.27	165.60	5.54	—	—	—	—	—	—	—	—
0903-H	89.75	1.01	115.25	1.64	144.20	2.57	169.88	3.53	195.47	4.64	221.10	5.89	246.71	7.29	272.24	8.83
1003-H	112.72	1.83	140.99	2.83	169.20	4.04	197.12	5.45	224.90	7.08	252.49	8.90	—	—	—	—
1206-H	127.44	1.09	159.96	1.71	188.37	2.32	216.63	3.03	—	—	—	—	—	—	—	—
1003-J	144.57	1.76	179.73	2.68	214.88	3.78	249.75	5.08	284.52	6.55	319.13	8.20	—	—	—	—
1104-J	164.31	1.61	202.48	2.41	240.45	3.37	273.54	4.29	310.50	5.54	—	—	—	—	—	—
1204-J	191.94	2.61	228.16	3.60	268.20	4.99	303.23	6.31	—	—	—	—	—	—	—	—

LEGEND

- Cap. — Capacity (Tons)
- EFT — Entering Fluid Temperature
- LFT — Leaving Fluid Temperature
- PD — Pressure Drop (PSIG)
- SET — Refrigerant Saturated Evaporator Temperature

NOTES:

1. Ratings based on 35 F saturated evaporator temperature. Fouling factor is 0.0005.
2. Shaded selections are 2-pass. All other selections are 4-pass.
3. LTD = LFT – SET
4. Range = EFT – LFT

Performance data (cont)



WATER RATINGS — R-134a 6 F WATER TEMPERATURE RANGE; 4 GPM/TON

UNIT 10RT	LEAVING TEMPERATURE DIFFERENCE (LTD) (F)															
	5		6		7		8		9		10		11		12	
	Cap.	PD	Cap.	PD	Cap.	PD	Cap.	PD	Cap.	PD	Cap.	PD	Cap.	PD	Cap.	PD
0401-A	—	—	—	—	2.37	0.93	3.46	1.56	4.42	2.53	5.52	3.97	6.47	5.43	7.41	7.07
0501-A	1.94	0.87	3.06	1.55	4.19	2.90	5.31	4.68	6.33	6.66	7.16	8.42	7.97	10.37	8.60	11.96
0501-B	2.86	0.84	4.46	1.38	6.20	2.68	7.93	4.42	9.27	5.96	10.66	7.89	11.82	9.56	12.73	11.12
0601-B	4.67	1.91	6.57	3.84	8.14	5.87	9.51	8.02	10.69	10.02	12.38	13.43	—	—	—	—
0401-C	—	—	—	—	7.05	1.03	9.86	1.80	12.66	3.00	15.07	4.20	17.48	5.54	19.79	7.05
0501-C	5.70	0.94	8.69	1.74	11.68	3.17	14.39	4.82	16.81	6.47	18.92	8.10	20.29	9.36	—	—
0602-C	8.00	1.04	10.94	1.72	13.80	2.77	16.08	3.72	18.18	4.82	21.82	6.85	—	—	—	—
0702-C	10.33	1.75	13.24	2.93	15.44	3.97	18.03	5.41	23.96	9.44	—	—	—	—	—	—
0503-D	—	—	10.33	0.74	14.97	1.00	19.59	1.48	23.47	2.10	27.54	2.93	30.82	3.67	33.50	4.35
0604-D	9.11	0.64	13.67	0.80	18.20	1.02	22.60	1.38	26.03	1.82	29.04	2.23	36.18	3.50	43.21	4.91
0702-D	15.67	1.75	20.00	2.86	23.64	4.01	26.71	5.10	34.81	8.54	44.04	13.48	—	—	—	—
0704-D	13.36	0.83	17.97	1.10	21.94	1.51	25.20	2.00	31.83	3.17	39.97	4.93	—	—	—	—
0804-D	21.64	0.66	20.32	1.47	23.43	1.94	32.19	3.65	41.38	6.00	—	—	—	—	—	—
0904-D	25.08	0.94	26.05	2.18	31.18	4.15	41.36	7.33	50.04	10.54	58.56	14.27	65.65	17.65	72.60	21.37
0804-E	33.14	0.72	31.52	2.13	36.23	2.79	49.33	5.06	63.39	8.26	—	—	—	—	—	—
0806-E	32.25	0.61	28.00	1.41	33.30	1.93	41.94	2.97	54.01	4.68	69.92	7.69	82.05	10.27	94.08	13.15
1004-F	43.61	2.03	54.46	3.50	67.59	5.35	79.55	7.31	91.41	9.57	102.79	12.13	113.10	14.59	63.00	17.28
1104-F	49.38	3.31	62.39	5.17	75.19	7.45	87.72	10.12	98.76	12.78	108.74	15.30	59.72	18.03	61.47	20.96
1004-G	55.60	1.73	64.71	2.92	81.53	4.61	98.15	6.68	113.42	8.83	128.42	11.26	141.85	13.62	154.99	16.18
1104-G	61.84	2.96	76.33	4.76	92.78	6.97	109.03	9.59	123.68	12.20	137.68	15.12	150.37	17.85	78.27	20.78
0903-H	58.37	1.70	72.39	2.57	93.21	4.25	111.04	5.89	131.93	8.30	152.70	11.10	—	—	—	—
1003-H	69.66	2.47	88.67	4.49	108.03	6.51	130.55	9.56	149.89	12.39	—	—	—	—	—	—
1206-H	83.23	1.71	102.44	2.74	124.56	4.01	144.62	5.32	163.64	6.81	180.67	8.23	102.67	9.78	105.64	11.45
1003-J	86.43	2.35	110.46	3.99	138.72	6.29	163.04	8.50	191.02	11.70	—	—	—	—	—	—
1104-J	98.00	2.27	126.47	3.73	152.49	5.32	178.43	7.19	205.72	9.61	228.35	11.71	250.39	14.02	—	—
1204-J	113.30	3.60	141.25	5.50	168.77	7.79	195.63	10.45	217.62	12.70	240.42	15.57	131.95	18.25	135.91	21.12

8 F WATER TEMPERATURE RANGE; 3 GPM/TON

UNIT 10RT	LEAVING TEMPERATURE DIFFERENCE (LTD) (F)															
	5		6		7		8		9		10		11		12	
	Cap.	PD	Cap.	PD	Cap.	PD	Cap.	PD	Cap.	PD	Cap.	PD	Cap.	PD	Cap.	PD
0401-A	—	—	—	—	2.84	0.85	3.80	1.11	4.90	1.75	5.99	2.63	6.94	3.53	7.86	4.57
0501-A	2.46	0.83	3.68	1.26	4.73	2.05	5.91	3.27	6.77	4.25	7.67	5.50	8.14	6.26	9.80	8.89
0501-B	3.66	0.81	5.40	1.15	7.02	1.92	8.61	2.90	10.15	4.08	11.42	5.18	11.50	5.19	14.06	7.67
0601-B	5.81	1.68	7.41	2.70	8.94	3.96	10.29	5.27	11.25	6.33	14.00	9.67	—	—	—	—
0401-C	—	—	5.67	0.70	8.46	0.94	11.28	1.32	14.08	2.08	16.49	2.84	18.82	3.71	21.10	4.64
0501-C	7.49	0.93	10.49	1.43	13.25	2.26	15.91	3.30	18.26	4.39	20.36	5.41	22.83	6.69	—	—
0602-C	9.80	0.96	12.71	1.32	15.22	1.90	17.42	2.49	19.67	3.16	24.82	5.02	30.57	7.52	36.31	10.50
0702-C	12.20	1.40	14.59	1.99	16.75	2.62	22.23	4.67	27.49	7.02	33.45	10.26	—	—	—	—
0503-D	—	—	12.60	0.71	16.86	0.86	21.46	1.08	25.24	1.38	28.94	1.82	32.26	2.26	37.23	3.04
0604-D	11.31	0.62	15.84	0.73	19.90	0.86	23.79	1.01	27.22	1.12	30.61	1.42	38.60	2.24	47.58	3.40
0702-D	18.34	1.36	22.08	1.94	25.63	2.65	32.05	4.13	41.29	6.89	50.47	10.18	58.55	13.48	—	—
0704-D	15.65	0.76	19.92	0.92	23.35	1.07	26.64	1.26	34.74	2.11	44.01	3.37	53.21	4.94	61.17	6.46
0804-D	18.44	0.91	22.13	1.09	27.62	1.53	36.83	2.69	46.07	4.19	55.11	6.01	62.81	7.71	—	—
0904-D	24.62	0.94	27.59	1.87	36.43	3.19	46.63	5.25	55.18	7.35	62.37	9.20	69.48	11.25	—	—
0804-E	28.70	1.09	34.02	1.41	42.34	2.13	58.38	4.06	72.48	6.19	84.54	8.27	97.96	11.08	—	—
0806-E	24.03	0.86	29.89	1.04	35.09	1.25	46.67	2.12	60.65	3.45	74.64	5.08	86.72	6.66	98.67	8.45
1004-F	49.83	1.70	61.99	2.56	76.19	3.87	88.01	5.12	98.66	6.35	109.18	7.71	120.21	9.42	—	—
1104-F	57.54	2.53	71.65	3.90	83.35	5.17	95.46	6.84	105.64	8.24	56.64	10.03	58.34	11.70	—	—
1004-G	60.41	1.48	75.94	2.29	92.89	3.39	109.43	4.72	123.22	5.89	136.89	7.19	151.35	8.83	—	—
1104-G	70.33	2.30	88.54	3.64	104.94	5.07	119.52	6.52	133.84	8.14	147.80	9.94	74.65	11.61	—	—
0903-H	65.99	1.23	85.33	2.02	106.46	3.11	127.37	4.44	145.41	5.67	165.81	7.41	183.42	8.96	200.91	10.65
1003-H	81.83	2.18	103.12	3.41	125.83	5.08	145.09	6.65	163.99	8.43	182.65	10.40	200.98	12.57	—	—
1206-H	93.90	1.33	116.23	2.00	137.99	2.81	157.44	3.63	176.41	4.55	96.94	5.42	99.80	6.37	102.61	7.21
1003-J	103.98	2.05	130.55	3.16	157.00	4.51	184.98	6.29	208.72	7.92	232.20	9.72	255.35	11.69	—	—
1104-J	117.08	1.83	145.75	2.79	171.97	3.82	197.25	5.00	222.01	6.34	244.65	7.63	—	—	—	—
1204-J	134.00	2.85	162.17	4.09	188.83	5.56	212.94	7.03	234.90	8.42	125.53	10.19	129.38	11.83	133.16	13.58

LEGEND

- Cap. — Capacity (Tons)
- EFT — Entering Fluid Temperature
- LFT — Leaving Fluid Temperature
- PD — Pressure Drop (PSIG)
- SET — Refrigerant Saturated Evaporator Temperature

NOTES:

1. Ratings based on 35 F saturated evaporator temperature. Fouling factor is 0.0005.
2. Shaded selections are 2-pass. All other selections are 4-pass.
3. LTD = LFT – SET
4. Range = EFT – LFT



WATER RATINGS — R-134a (cont)
10 F WATER TEMPERATURE RANGE; 2.4 GPM/TON

UNIT 10RT	LEAVING TEMPERATURE DIFFERENCE (LTD) (F)															
	5		6		7		8		9		10		11		12	
	Cap.	PD	Cap.	PD	Cap.	PD	Cap.	PD	Cap.	PD	Cap.	PD	Cap.	PD	Cap.	PD
0401-A	—	—	2.21	0.64	3.17	0.78	4.26	1.00	5.35	1.34	6.31	1.87	7.26	2.47	8.19	3.16
0501-A	3.06	0.83	4.11	1.09	5.30	1.68	6.32	2.39	7.19	3.06	8.15	4.00	9.00	4.85	10.66	6.75
0501-B	4.45	0.80	6.06	1.04	7.67	1.46	9.25	2.14	10.78	2.95	12.07	3.69	13.33	4.52	15.90	6.38
0601-B	6.60	1.39	8.17	2.11	9.69	3.00	11.04	3.90	13.16	5.57	15.61	7.71	18.68	10.96	—	—
0401-C	—	—	7.05	0.70	9.85	0.88	12.28	1.08	15.06	1.51	17.46	2.03	19.84	2.62	22.12	3.30
0501-C	9.00	0.90	11.98	1.19	14.69	1.80	17.32	2.53	19.51	3.18	21.53	3.92	26.33	5.78	31.19	7.95
0602-C	10.95	0.87	13.82	1.08	16.33	1.40	18.54	1.80	23.19	2.84	27.79	4.02	33.51	5.84	39.19	7.94
0702-C	13.34	1.12	15.86	1.51	18.94	2.14	25.67	3.98	30.93	5.74	36.81	8.07	42.01	10.36	—	—
0503-D	9.81	0.58	14.05	0.66	18.66	0.79	22.49	0.91	26.29	1.06	30.02	1.24	31.80	1.41	39.32	2.15
0604-D	12.51	0.59	17.02	0.67	21.02	0.76	24.93	0.86	28.37	0.96	33.92	1.13	40.97	1.62	49.93	2.40
0702-D	20.08	1.11	24.02	1.49	28.03	2.02	37.33	3.60	46.56	5.65	54.62	7.68	62.65	9.98	70.60	12.56
0704-D	17.28	0.71	21.27	0.81	24.71	0.91	29.43	1.07	39.78	1.80	47.90	2.58	56.02	3.50	64.04	4.57
0804-D	19.97	0.81	23.67	0.93	32.15	1.34	41.35	2.19	50.46	3.26	58.38	4.31	67.14	5.76	73.76	6.80
0904-D	24.22	0.97	31.28	1.52	41.48	2.68	50.23	3.89	58.85	5.34	67.17	7.01	—	—	—	—
0804-E	31.07	0.95	36.43	1.11	51.27	2.05	65.31	3.28	79.26	4.80	91.30	6.29	103.12	7.93	114.79	9.72
0806-E	25.76	0.77	31.59	0.90	37.40	1.05	51.31	1.68	63.36	2.45	77.25	3.55	89.29	4.62	102.90	6.08
1004-F	55.93	1.37	69.12	2.06	82.14	2.90	94.04	3.76	105.70	4.73	116.21	5.67	—	—	—	—
1104-F	65.21	2.11	78.08	2.98	90.70	4.00	102.13	5.02	113.11	6.15	—	—	—	—	68.28	9.76
1004-G	68.42	1.21	86.70	1.94	102.19	2.65	117.57	3.48	132.55	4.40	147.25	5.44	159.76	6.29	—	—
1104-G	80.50	1.95	98.52	2.92	113.61	3.80	128.38	4.81	143.79	6.09	—	—	—	—	87.46	9.51
0903-H	76.80	1.07	98.00	1.71	119.14	2.51	140.04	3.46	157.88	4.33	178.27	5.54	195.90	6.62	213.41	7.79
1003-H	93.92	1.83	116.89	2.83	136.47	3.78	158.56	5.15	177.46	6.40	196.09	7.78	—	—	—	—
1206-H	104.96	1.07	127.07	1.55	147.06	2.04	166.71	2.60	185.89	3.22	94.67	3.91	—	—	—	—
1003-J	119.04	1.71	145.72	2.51	174.18	3.59	200.07	4.71	225.57	5.99	249.05	7.24	—	—	—	—
1104-J	133.11	1.52	161.62	2.21	189.66	3.03	214.93	3.87	237.98	4.69	—	—	—	—	—	—
1204-J	151.02	2.33	178.80	3.23	205.72	4.27	228.20	5.14	119.42	6.26	123.21	7.48	—	—	—	—

12 F WATER TEMPERATURE RANGE; 2 GPM/TON

UNIT 10RT	LEAVING TEMPERATURE DIFFERENCE (LTD) (F)															
	5		6		7		8		9		10		11		12	
	Cap.	PD	Cap.	PD	Cap.	PD	Cap.	PD	Cap.	PD	Cap.	PD	Cap.	PD	Cap.	PD
0401-A	—	—	2.53	0.63	3.48	0.73	4.58	0.90	5.66	1.11	6.62	1.43	7.57	1.87	8.51	2.37
0501-A	3.47	0.80	4.52	0.99	5.71	1.36	6.73	1.88	7.59	2.37	8.15	2.78	9.82	4.01	11.49	5.48
0501-B	5.07	0.77	6.68	0.96	8.29	1.20	9.86	1.70	11.30	2.23	11.49	2.30	14.60	3.77	17.17	5.21
0601-B	7.20	1.15	8.91	1.76	10.31	2.34	11.60	3.00	14.69	4.84	17.14	6.50	20.21	9.00	23.26	11.86
0401-C	5.41	0.58	7.99	0.68	10.80	0.82	13.22	0.97	16.01	1.19	18.74	1.65	20.80	2.00	21.67	2.19
0501-C	10.18	0.86	13.17	1.09	15.88	1.46	18.51	2.01	20.71	2.49	23.97	3.36	28.78	4.82	33.62	6.47
0602-C	12.03	0.81	14.90	0.98	17.42	1.11	19.65	1.40	24.81	2.23	30.62	3.41	36.33	4.83	40.92	6.00
0702-C	14.59	1.02	17.09	1.23	22.25	2.07	28.26	3.35	34.22	4.94	39.46	6.48	44.67	8.19	49.84	10.09
0503-D	11.18	0.57	15.03	0.63	19.64	0.72	23.84	0.82	27.95	0.95	31.65	1.07	33.79	1.14	41.30	1.64
0604-D	13.62	0.58	18.12	0.64	22.13	0.70	26.05	0.78	29.49	0.85	36.18	1.02	43.22	1.26	52.15	1.83
0702-D	21.98	1.01	25.91	1.22	32.01	1.84	41.30	3.07	50.58	4.63	58.67	6.20	66.70	7.92	74.66	9.84
0704-D	18.58	0.67	22.59	0.75	26.04	0.82	32.13	0.98	42.44	1.43	50.57	2.01	58.71	2.68	66.83	3.46
0804-D	21.46	0.75	26.07	0.87	35.24	1.12	44.43	1.76	53.57	2.56	61.51	3.33	70.43	4.40	78.02	5.39
0904-D	25.92	0.94	34.76	1.32	44.97	2.19	53.75	3.10	62.40	4.17	70.85	5.40	—	—	—	—
0804-E	33.39	0.87	41.99	1.07	56.03	1.70	70.09	2.63	84.08	3.76	97.90	5.09	108.22	6.09	121.36	7.70
0806-E	27.00	0.71	32.89	0.81	39.88	0.94	53.78	1.30	65.83	1.87	79.75	2.68	93.54	3.62	105.50	4.52
1004-F	61.60	1.17	73.86	1.63	87.96	2.32	99.92	2.96	111.68	3.68	—	—	—	—	—	—
1104-F	70.31	1.70	83.33	2.35	96.09	3.10	108.48	3.96	—	—	—	—	—	—	—	—
1004-G	75.90	1.04	94.30	1.60	109.90	2.14	125.39	2.75	140.68	3.44	155.46	4.20	—	—	—	—
1104-G	88.68	1.66	106.81	2.39	123.25	3.16	138.16	3.92	—	—	—	—	—	—	—	—
0903-H	85.53	0.92	106.86	1.41	128.19	2.01	149.41	2.72	170.18	3.53	188.04	4.25	208.23	5.25	—	—
1003-H	105.26	1.62	126.78	2.30	149.66	3.21	169.03	4.04	188.12	4.96	206.91	5.97	—	—	—	—
1206-H	113.47	0.88	135.76	1.23	157.59	1.65	177.28	2.06	—	—	—	—	—	—	—	—
1003-J	133.15	1.50	162.06	2.20	190.64	3.03	214.92	3.78	238.91	4.62	265.64	5.79	—	—	—	—
1104-J	146.00	1.27	176.83	1.86	203.04	2.41	228.86	3.03	253.69	3.73	—	—	—	—	—	—
1204-J	165.03	1.94	193.05	2.61	220.34	3.39	244.79	4.15	—	—	—	—	—	—	153.43	7.48

LEGEND

- Cap. — Capacity (Tons)
- EFT — Entering Fluid Temperature
- LFT — Leaving Fluid Temperature
- PD — Pressure Drop (PSIG)
- SET — Refrigerant Saturated Evaporator Temperature

NOTES:

1. Ratings based on 35 F saturated evaporator temperature. Fouling factor is 0.0005.
2. Shaded selections are 2-pass. All other selections are 4-pass.
3. LTD = LFT – SET
4. Range = EFT – LFT

Performance data (cont)



WATER RATINGS — R-507/404A 6 F WATER TEMPERATURE RANGE; 4 GPM/TON

UNIT 10RT	LEAVING TEMPERATURE DIFFERENCE (LTD) (F)															
	5		6		7		8		9		10		11		12	
	Cap.	PD	Cap.	PD	Cap.	PD	Cap.	PD	Cap.	PD	Cap.	PD	Cap.	PD	Cap.	PD
0401-A	—	—	2.20	0.87	3.31	1.42	4.72	2.90	6.01	4.67	7.29	6.78	8.80	9.90	7.26	6.78
0501-A	2.67	1.17	4.28	3.04	5.74	5.42	7.17	8.42	5.70	5.43	7.37	8.89	—	—	—	—
0501-B	3.98	1.11	6.33	2.82	8.57	5.15	10.77	8.12	8.26	4.79	10.83	8.12	—	—	—	—
0601-B	6.59	3.83	8.93	7.04	11.07	10.73	9.35	7.69	—	—	—	—	—	—	—	—
0401-C	—	—	6.57	0.97	9.88	1.80	13.24	3.22	16.95	5.25	20.65	7.70	16.90	5.25	20.79	7.70
0501-C	8.09	1.50	12.02	3.33	16.14	6.03	19.75	8.85	15.66	5.62	—	—	—	—	—	—
0602-C	10.95	1.72	15.28	3.38	18.95	5.20	16.77	4.07	23.24	7.75	—	—	—	—	—	—
0702-C	14.56	3.53	11.95	2.39	18.00	5.41	24.87	10.09	—	—	—	—	—	—	—	—
0503-D	—	—	14.90	1.00	20.59	1.62	27.02	2.82	32.60	4.12	27.97	3.03	35.55	4.82	44.83	7.55
0604-D	—	—	19.24	1.09	25.01	1.66	—	—	28.34	2.15	38.49	3.95	—	—	—	—
0702-D	21.94	3.45	—	—	26.65	5.09	37.27	9.84	—	—	—	—	—	—	—	—
0704-D	18.64	1.14	24.68	1.89	—	—	31.93	3.16	42.64	5.59	—	—	—	—	—	—
0804-D	22.90	1.87	—	—	32.19	3.64	44.36	6.89	—	—	—	—	—	—	—	—
0904-D	—	—	31.04	4.14	43.22	7.94	55.35	12.71	67.42	18.54	—	—	—	—	—	—
0804-E	35.15	2.61	32.81	2.29	51.30	5.54	67.93	9.46	—	—	—	—	—	—	—	—
0806-E	29.32	1.51	38.53	2.52	39.70	2.67	56.18	5.06	74.87	8.67	93.34	13.14	108.24	16.99	—	—
1004-F	43.98	2.33	58.76	4.07	73.66	6.29	88.60	8.98	105.54	12.81	—	—	—	—	—	—
1104-F	52.71	3.74	69.95	6.55	85.92	9.76	101.86	13.60	—	—	—	—	—	—	—	—
1004-G	—	—	68.42	3.26	87.37	5.26	106.43	7.72	128.21	11.26	147.30	14.70	—	—	—	—
1104-G	62.05	3.16	82.57	5.54	103.09	8.56	123.64	12.20	144.11	16.46	—	—	—	—	—	—
0903-H	72.00	2.57	74.51	2.72	97.52	4.64	119.21	6.81	144.29	9.94	—	—	—	—	—	—
1003-H	69.96	2.83	93.40	4.96	117.10	7.66	141.11	10.93	—	—	—	—	—	—	—	—
1206-H	85.71	1.94	113.38	3.35	141.19	5.12	166.77	7.04	—	—	—	—	—	—	—	—
1003-J	86.96	2.51	116.20	4.41	147.92	7.08	179.96	10.36	—	—	—	—	—	—	—	—
1104-J	101.64	2.41	133.79	4.10	170.59	6.69	202.99	9.32	235.46	12.36	—	—	—	—	—	—
1204-J	120.82	4.04	157.94	6.88	192.64	10.10	227.22	13.90	—	—	—	—	—	—	—	—

8 F WATER TEMPERATURE RANGE; 3 GPM/TON

UNIT 10RT	LEAVING TEMPERATURE DIFFERENCE (LTD) (F)															
	5		6		7		8		9		10		11		12	
	Cap.	PD	Cap.	PD	Cap.	PD	Cap.	PD	Cap.	PD	Cap.	PD	Cap.	PD	Cap.	PD
0401-A	—	—	2.68	0.81	3.94	1.14	5.35	2.10	6.65	3.21	8.17	4.93	6.62	3.22	8.22	4.93
0501-A	3.49	1.13	5.10	2.42	6.56	3.98	7.99	5.93	6.57	3.99	8.96	7.52	10.68	10.37	—	—
0501-B	5.10	1.10	7.34	2.10	9.59	3.58	11.80	5.46	10.14	4.08	12.74	6.38	15.93	9.81	—	—
0601-B	8.12	3.29	10.45	5.46	8.53	3.62	11.68	6.77	15.50	11.85	—	—	—	—	—	—
0401-C	5.18	0.67	8.44	0.94	11.77	1.44	15.52	2.52	18.88	3.71	22.55	5.25	19.74	4.07	24.45	6.12
0501-C	10.74	1.51	14.44	2.69	18.56	4.52	14.43	2.70	20.30	5.41	25.23	8.10	—	—	—	—
0602-C	13.47	1.47	17.48	2.49	14.57	1.73	20.44	3.40	27.58	6.21	33.59	8.95	—	—	—	—
0702-C	17.11	2.75	15.47	2.23	22.37	4.67	30.00	8.34	—	—	—	—	—	—	—	—
0503-D	—	—	16.90	0.86	23.35	1.18	29.04	1.82	24.19	1.28	31.75	2.19	41.00	3.68	48.74	5.07
0604-D	15.31	0.72	21.53	0.92	27.27	1.12	22.76	0.96	31.82	1.52	42.96	2.79	52.28	4.07	—	—
0702-D	25.39	2.58	22.69	2.06	33.34	4.48	45.15	8.22	55.92	12.33	—	—	—	—	—	—
0704-D	21.38	0.98	27.35	1.32	26.62	1.26	37.25	2.43	48.05	4.00	58.81	5.93	—	—	—	—
0804-D	—	—	27.50	1.53	39.63	3.15	51.85	5.36	62.75	7.70	—	—	—	—	—	—
0904-D	25.88	1.65	38.02	3.49	51.66	6.45	62.42	9.20	74.35	12.90	—	—	—	—	—	—
0804-E	—	—	42.17	2.13	60.78	4.38	79.45	7.41	97.95	11.07	—	—	—	—	—	—
0806-E	32.84	1.10	—	—	46.63	2.12	61.18	3.44	79.90	5.68	98.66	8.44	117.04	11.68	—	—
1004-F	52.92	1.90	67.87	3.05	85.11	4.79	100.04	6.54	114.99	8.55	—	—	—	—	—	—
1104-F	63.78	3.10	80.01	4.79	96.14	6.84	112.10	9.24	—	—	—	—	—	—	—	—
1004-G	64.12	1.67	83.10	2.75	102.27	4.10	121.39	5.71	140.58	7.59	159.71	9.71	—	—	—	—
1104-G	77.98	2.86	98.72	4.51	119.27	6.52	139.79	8.89	—	—	—	—	—	—	—	—
0903-H	68.15	1.31	89.59	2.22	114.59	3.62	136.49	5.04	161.69	7.05	186.96	9.37	212.18	12.01	—	—
1003-H	86.53	2.43	112.16	4.04	136.09	5.84	163.49	8.43	187.70	10.93	—	—	—	—	—	—
1206-H	102.41	1.57	132.24	2.60	160.04	3.75	187.58	5.12	—	—	—	—	—	—	—	—
1003-J	109.80	2.27	139.57	3.59	173.66	5.55	207.83	7.92	238.10	10.20	—	—	—	—	—	—
1104-J	126.55	2.13	159.14	3.29	196.05	5.00	228.52	6.69	—	—	—	—	—	—	—	—
1204-J	148.04	3.44	185.40	5.37	220.09	7.48	—	—	—	—	—	—	—	—	—	—

LEGEND

- Cap. — Capacity (Tons)
- EFT — Entering Fluid Temperature
- LFT — Leaving Fluid Temperature
- PD — Pressure Drop (PSIG)
- SET — Refrigerant Saturated Evaporator Temperature

NOTES:

1. Ratings based on 35 F saturated evaporator temperature. Fouling factor is 0.0005.
2. Shaded selections are 2-pass. All other selections are 4-pass.
3. LTD = LFT – SET
4. Range = EFT – LFT



WATER RATINGS — R-507/404A (cont)
10 F WATER TEMPERATURE RANGE; 2.4 GPM/TON—

UNIT 10RT	LEAVING TEMPERATURE DIFFERENCE (LTD) (F)															
	5		6		7		8		9		10		11		12	
	Cap.	PD	Cap.	PD	Cap.	PD	Cap.	PD	Cap.	PD	Cap.	PD	Cap.	PD	Cap.	PD
0401-A	—	—	3.16	0.78	4.42	1.03	5.97	1.68	7.26	2.47	8.54	3.41	7.55	2.69	9.43	4.22
0501-A	4.28	1.10	5.74	1.95	7.33	3.23	5.74	1.95	7.79	3.61	9.85	5.77	12.26	8.89	14.68	12.63
0501-B	6.06	1.04	8.31	1.72	10.78	2.94	8.30	1.72	11.46	3.31	14.64	5.42	17.83	7.94	—	—
0601-B	9.13	2.64	11.27	4.03	10.13	3.24	13.98	6.24	17.82	10.09	—	—	—	—	—	—
0401-C	6.59	0.67	9.88	0.88	13.23	1.15	17.01	1.92	20.71	2.87	17.86	2.14	22.56	3.43	27.30	4.92
0501-C	12.60	1.31	16.75	2.35	20.36	3.48	17.97	2.71	23.89	4.82	28.88	6.82	—	—	—	—
0602-C	15.30	1.22	18.97	1.87	17.52	1.59	24.70	3.21	30.69	4.91	37.90	7.38	45.15	10.34	—	—
0702-C	12.87	1.08	19.70	2.33	27.39	4.53	34.36	7.02	42.70	10.77	—	—	—	—	—	—
0503-D	13.95	0.66	19.60	0.82	25.28	1.02	30.87	1.32	26.26	1.06	35.48	1.75	44.83	2.80	54.13	4.08
0604-D	17.07	0.67	23.70	0.83	28.89	0.98	27.12	0.93	36.20	1.28	45.46	1.99	56.73	3.09	67.89	4.43
0702-D	—	—	29.20	2.22	39.94	4.13	50.76	6.64	63.66	10.38	74.33	13.95	—	—	—	—
0704-D	23.88	0.89	—	—	30.66	1.12	42.47	2.04	53.29	3.18	64.17	4.56	74.78	6.14	—	—
0804-D	—	—	32.19	1.34	44.40	2.52	57.92	4.30	67.62	5.75	—	—	—	—	—	—
0904-D	31.17	1.52	44.83	3.13	57.09	5.02	69.04	7.35	—	—	—	—	—	—	—	—
0804-E	32.91	1.00	51.37	2.04	70.07	3.75	88.91	5.96	105.45	8.27	121.87	10.88	—	—	—	—
0806-E	35.15	0.98	35.13	0.98	51.42	1.68	69.93	2.97	88.55	4.62	103.41	6.07	121.78	8.30	—	—
1004-F	61.62	1.66	76.72	2.51	93.97	3.76	108.89	4.99	—	—	—	—	—	—	—	—
1104-F	73.33	2.64	89.57	3.87	105.65	5.33	—	—	—	—	—	—	—	—	—	—
1004-G	75.41	1.48	94.63	2.29	114.05	3.26	135.74	4.65	152.14	5.71	—	—	—	—	—	—
1104-G	90.45	2.46	111.36	3.67	131.89	5.11	152.03	6.79	—	—	—	—	—	—	—	—
0903-H	80.99	1.18	106.05	2.02	128.18	2.87	153.47	4.10	178.65	5.54	203.61	7.19	—	—	—	—
1003-H	102.77	2.21	130.49	3.53	154.66	4.86	178.64	6.40	205.59	8.52	—	—	—	—	—	—
1206-H	116.51	1.30	144.48	1.97	172.08	2.77	—	—	—	—	—	—	—	—	—	—
1003-J	127.77	1.96	162.38	3.13	196.80	4.58	226.78	5.99	260.51	7.92	—	—	—	—	—	—
1104-J	146.11	1.81	183.71	2.84	216.12	3.87	248.18	5.06	—	—	—	—	—	—	—	—
1204-J	171.92	2.99	206.87	4.27	241.04	5.76	—	—	—	—	—	—	—	—	—	—

12 F WATER TEMPERATURE RANGE; 2 GPM/TON

UNIT 10RT	LEAVING TEMPERATURE DIFFERENCE (LTD) (F)															
	5		6		7		8		9		10		11		12	
	Cap.	PD	Cap.	PD	Cap.	PD	Cap.	PD	Cap.	PD	Cap.	PD	Cap.	PD	Cap.	PD
0401-A	2.37	0.61	3.49	0.73	4.89	0.96	6.30	1.29	7.58	1.87	8.86	2.54	8.21	2.20	10.10	3.33
0501-A	4.71	1.04	6.17	1.55	7.76	2.50	6.93	2.00	8.99	3.36	11.40	5.46	13.15	7.09	15.57	9.87
0501-B	6.98	1.00	9.21	1.48	11.43	2.29	10.14	1.81	12.77	2.84	16.51	4.81	19.71	6.80	22.93	9.07
0601-B	10.05	2.25	8.56	1.61	12.39	3.42	15.61	5.35	19.45	8.34	23.31	11.86	—	—	—	—
0401-C	7.56	0.66	11.28	0.85	15.01	1.11	18.37	1.56	21.72	2.18	20.63	2.00	24.58	2.80	30.13	4.20
0501-C	14.33	1.19	18.01	1.87	15.56	1.40	21.49	2.71	26.47	4.07	33.45	6.47	38.54	8.34	—	—
0602-C	16.72	1.09	14.59	0.95	20.46	1.51	27.67	2.79	34.89	4.46	40.91	6.00	48.10	8.22	—	—
0702-C	16.25	1.11	23.15	2.23	30.87	3.98	37.86	5.95	46.13	8.80	53.07	11.47	—	—	—	—
0503-D	14.99	0.63	20.64	0.74	27.03	0.92	31.93	1.07	29.92	1.00	39.18	1.49	48.56	2.29	57.92	3.26
0604-D	18.22	0.64	24.83	0.75	—	—	29.48	0.85	38.61	1.09	49.76	1.68	59.11	2.33	70.36	3.31
0702-D	22.70	1.04	34.48	2.15	45.28	3.69	56.13	5.65	66.89	7.92	79.57	11.23	—	—	—	—
0704-D	25.25	0.80	24.06	0.77	34.63	1.06	45.33	1.61	56.14	2.44	69.08	3.73	79.70	4.95	—	—
0804-D	24.62	0.82	36.74	1.22	48.95	2.14	61.16	3.32	73.28	4.77	—	—	—	—	—	—
0904-D	36.28	1.44	48.52	2.53	62.08	4.16	72.91	5.65	—	—	—	—	—	—	—	—
0804-E	39.83	1.01	56.42	1.70	75.17	2.98	93.95	4.62	112.46	6.61	—	—	—	—	—	—
0806-E	36.43	0.87	39.75	0.94	56.07	1.41	72.59	2.26	89.25	3.29	107.76	4.70	—	—	—	—
1004-F	67.67	1.39	84.97	2.18	100.11	2.96	117.18	4.07	—	—	—	—	—	—	—	—
1104-F	79.88	2.18	98.39	3.31	114.47	4.42	—	—	—	—	—	—	—	—	—	—
1004-G	83.36	1.25	102.73	1.86	124.90	2.75	144.23	3.62	—	—	—	—	—	—	—	—
1104-G	99.15	2.05	121.59	3.06	143.75	4.27	—	—	—	—	—	—	—	—	—	—
0903-H	93.49	1.10	118.77	1.76	144.20	2.57	169.48	3.53	191.66	4.44	216.73	5.67	—	—	—	—
1003-H	116.59	1.98	141.01	2.83	168.72	4.04	195.94	5.45	—	—	—	—	—	—	—	—
1206-H	127.58	1.09	155.58	1.59	183.35	2.19	—	—	—	—	—	—	—	—	—	—
1003-J	145.01	1.76	179.78	2.68	214.32	3.78	244.50	4.85	—	—	—	—	—	—	—	—
1104-J	164.53	1.61	202.03	2.41	234.87	3.20	—	—	—	—	—	—	—	—	—	—
1204-J	186.76	2.44	226.80	3.60	—	—	—	—	—	—	—	—	—	—	—	—

LEGEND

- Cap. — Capacity (Tons)
- EFT — Entering Fluid Temperature
- LFT — Leaving Fluid Temperature
- PD — Pressure Drop (PSIG)
- SET — Refrigerant Saturated Evaporator Temperature

NOTES:

1. Ratings based on 35 F saturated evaporator temperature. Fouling factor is 0.0005.
2. Shaded selections are 2-pass. All other selections are 4-pass.
3. LTD = LFT – SET
4. Range = EFT – LFT

Performance data (cont)



BRINE RATINGS — R-22 20 F SET, ETHYLENE GLYCOL SOLUTION (20%)

UNIT 10RT	6 F RANGE				8 F RANGE				10 F RANGE				12 F RANGE			
	8 F LTD		10 F LTD		8 F LTD		10 F LTD		8 F LTD		10 F LTD		8 F LTD		10 F LTD	
	Cap.	PD	Cap.	PD	Cap.	PD	Cap.	PD	Cap.	PD	Cap.	PD	Cap.	PD	Cap.	PD
0401-A	2.53	1.11	4.75	3.54	2.69	0.89	5.03	2.29	2.84	0.78	5.04	1.48	2.85	0.70	5.03	1.11
0501-A	4.91	4.85	7.39	10.78	5.30	3.23	7.59	6.43	5.34	2.09	7.77	4.38	5.53	1.58	7.81	3.06
0501-B	9.89	10.39	—	—	10.44	6.61	12.42	9.21	10.83	4.58	13.23	6.70	11.07	3.32	14.01	5.24
0401-C	8.02	1.47	14.17	4.44	8.92	1.11	15.04	2.87	9.40	0.94	15.12	1.86	9.46	0.81	15.54	1.38
0501-C	14.37	5.77	13.21	4.87	5.54	3.85	21.28	7.10	16.17	2.68	22.10	4.95	16.77	2.02	18.00	2.30
0602-C	16.68	4.91	19.01	6.23	17.40	3.05	21.74	4.70	17.82	2.05	23.20	3.45	18.23	1.50	23.38	2.42
0702-C	18.92	7.12	—	—	18.82	4.06	32.46	11.95	20.59	3.12	34.26	8.47	22.30	2.55	35.91	6.48
0704-D	25.25	2.44	34.53	4.47	25.36	1.40	34.68	2.56	25.41	1.03	34.79	1.66	25.93	0.89	37.13	1.35
0804-D	27.93	3.37	—	—	29.09	2.09	49.12	5.71	30.66	1.50	51.85	4.16	32.14	1.16	51.98	2.93
0904-D	37.98	7.42	59.03	17.42	41.35	5.03	62.21	11.04	43.22	3.54	62.60	7.14	44.87	2.68	65.52	5.57
0804-E	42.16	4.53	—	—	46.69	3.19	79.25	8.83	49.13	2.29	79.75	5.75	51.44	1.76	80.00	4.05
1004-F	76.64	8.53	—	—	82.37	5.65	111.42	10.14	85.61	3.93	114.60	6.91	88.58	2.96	117.72	5.10
1004-G	95.02	7.77	132.98	14.88	105.56	5.54	140.55	9.46	110.18	3.86	147.55	6.79	117.09	3.09	152.02	5.00
1003-H	131.16	11.96	—	—	144.91	8.33	192.18	14.29	154.58	6.09	201.65	10.14	163.73	4.80	211.00	7.76
1003-J	167.49	11.38	—	—	180.45	7.40	—	—	196.61	5.73	255.53	9.42	207.98	4.50	267.15	7.20
0601-B	9.89	10.39	—	—	10.44	6.61	12.42	9.21	10.83	4.58	13.23	6.70	11.07	3.32	14.01	5.24
0503-D	23.80	3.42	27.11	4.44	24.86	2.14	28.32	2.74	24.98	1.38	29.51	1.91	25.50	1.09	31.63	1.55
0604-D	19.37	1.24	29.36	2.81	19.37	0.91	28.87	1.55	19.34	0.77	28.37	1.07	19.26	0.69	28.29	0.90
0702-D	28.72	7.09	42.76	15.65	29.98	4.42	45.52	9.92	29.33	2.73	50.40	7.93	31.93	2.27	50.74	5.55
0806-E	37.30	2.87	56.18	6.05	36.41	1.59	56.05	3.56	36.26	1.12	55.94	2.36	35.29	0.92	53.79	1.56
1104-F	89.09	13.13	—	—	95.35	8.59	121.50	13.53	98.88	5.95	—	—	102.33	4.45	—	—
1104-G	111.33	12.46	148.69	21.74	120.02	8.18	156.56	13.77	127.76	6.04	164.31	9.85	135.37	4.79	—	—
0903-H	106.91	6.85	—	—	119.24	4.88	166.39	9.24	128.12	3.62	174.94	6.59	136.27	2.89	183.21	5.07
1205-H	154.27	10.49	—	—	163.45	6.65	—	—	171.60	4.75	—	—	177.82	3.56	—	—
1104-J	183.80	9.63	—	—	197.55	6.27	259.84	10.75	209.87	4.59	272.16	7.63	221.86	3.61	280.53	5.59
1204-J	206.34	14.46	—	—	220.93	9.36	—	—	234.28	6.82	—	—	247.41	5.35	—	—
0902-L	185.50	5.71	—	—	208.80	4.10	—	—	231.67	3.26	316.49	5.95	247.48	2.59	332.72	4.57
1002-L	—	—	—	—	256.20	7.35	—	—	275.19	5.39	—	—	299.05	4.50	385.58	7.31
1103-L	254.05	12.41	—	—	282.15	8.69	—	—	301.85	6.38	393.27	10.79	327.14	5.33	412.78	8.27
1203-L	—	—	—	—	316.79	10.92	—	—	337.98	7.98	—	—	358.80	6.27	—	—

10 F SET, ETHYLENE GLYCOL SOLUTION (30%)

UNIT 10RT	6 F RANGE				8 F RANGE				10 F RANGE				12 F RANGE			
	8 F LTD		10 F LTD		8 F LTD		10 F LTD		8 F LTD		10 F LTD		8 F LTD		10 F LTD	
	Cap.	PD	Cap.	PD	Cap.	PD	Cap.	PD	Cap.	PD	Cap.	PD	Cap.	PD	Cap.	PD
0401-A	—	—	3.48	2.17	—	—	3.32	1.13	—	—	3.16	0.90	—	—	2.84	0.75
0501-A	3.68	3.09	5.92	7.82	3.69	1.77	5.91	4.46	3.69	1.14	5.73	2.69	3.67	0.98	5.71	1.89
0501-B	7.77	7.17	10.66	13.35	7.96	4.28	10.70	7.59	7.96	2.76	10.84	5.08	7.97	1.93	10.87	3.55
0401-C	5.67	0.99	11.25	3.21	—	—	10.83	1.69	5.64	0.71	10.81	1.14	5.88	0.67	10.37	0.91
0501-C	11.36	4.10	16.80	8.70	11.43	2.34	16.82	4.97	11.95	1.68	16.84	3.22	11.96	1.17	16.86	2.25
0602-C	13.04	3.40	17.80	6.19	13.09	1.94	17.81	3.53	13.07	1.26	17.82	2.29	13.06	1.01	17.83	1.60
0702-C	15.41	5.37	—	—	15.78	3.23	24.86	7.75	15.89	2.09	25.69	5.35	16.25	1.55	25.74	3.75
0704-D	18.65	1.50	25.93	2.83	16.69	0.92	25.29	1.55	16.72	0.79	24.65	1.06	16.70	0.71	22.64	0.85
0804-D	21.85	2.31	36.74	6.31	21.53	1.28	36.63	3.62	21.45	1.00	35.26	2.16	20.63	0.84	33.82	1.40
0904-D	27.80	4.44	48.21	13.06	29.34	2.86	48.25	7.48	29.41	1.86	46.81	4.53	29.39	1.31	46.69	3.18
0804-E	34.01	3.31	58.41	9.39	33.94	1.91	56.36	4.99	33.88	1.24	56.26	3.25	31.71	0.97	56.05	2.29
1004-F	64.76	7.08	91.25	13.48	67.45	4.49	91.63	7.78	67.78	2.98	93.80	5.42	67.88	2.13	94.03	3.85
1004-G	83.29	6.92	117.42	13.22	87.23	4.38	121.06	8.09	90.87	3.13	124.39	5.61	92.78	2.32	125.16	3.98
1003-H	116.91	10.85	—	—	125.89	7.25	168.21	12.48	130.89	5.09	173.12	8.56	135.53	3.86	177.94	6.36
1003-J	145.52	9.64	—	—	156.64	6.44	213.72	11.68	162.86	4.52	219.76	8.00	168.56	3.42	225.71	5.93
0601-B	7.77	7.17	10.66	13.35	7.96	4.28	10.70	7.59	7.96	2.76	10.84	5.08	7.97	1.93	10.87	3.55
0503-D	18.07	2.24	26.02	4.54	17.60	1.20	25.49	2.48	15.85	0.89	24.96	1.54	15.89	0.79	24.85	1.13
0604-D	13.57	0.92	21.61	1.70	12.44	0.72	20.44	1.01	12.44	0.65	18.11	0.78	12.41	0.61	17.61	0.69
0702-D	23.24	5.28	34.64	11.41	23.34	3.01	34.77	6.50	23.41	1.95	36.01	4.53	23.92	1.44	37.15	3.41
0806-E	24.69	1.48	37.59	3.12	24.62	1.02	35.17	1.65	24.54	0.85	32.80	1.07	24.47	0.75	32.68	0.92
1104-F	75.08	10.65	—	—	78.19	6.70	102.24	10.99	79.70	4.58	104.83	7.62	80.07	3.27	105.48	5.40
1104-G	96.95	10.79	130.12	18.80	102.93	7.03	134.08	11.48	106.76	4.97	138.00	7.94	107.70	3.54	140.62	5.77
0903-H	95.76	6.36	—	—	102.11	4.17	144.91	7.99	106.64	2.96	149.06	5.52	110.63	2.27	153.09	4.11
1205-H	132.26	8.86	172.31	14.34	137.77	5.56	177.12	8.79	138.85	3.67	181.94	6.10	143.59	2.82	183.46	4.32
1104-J	159.08	8.18	216.13	14.67	170.72	5.48	222.40	8.91	176.81	3.85	228.59	6.13	178.34	2.74	234.72	4.57
1204-J	179.40	12.36	—	—	189.34	7.93	240.76	12.49	196.27	5.56	—	—	203.08	4.21	—	—
0902-L	170.18	5.46	—	—	185.82	3.72	263.60	7.18	201.07	2.83	278.22	5.21	209.35	2.16	292.34	4.07
1002-L	206.37	9.39	—	—	230.37	6.77	—	—	247.00	5.06	324.27	8.43	256.72	3.81	334.63	6.24
1103-L	233.58	12.03	—	—	252.48	8.02	328.13	13.12	263.06	5.62	339.24	9.00	273.30	4.25	355.79	7.03
1203-L	260.39	14.70	—	—	277.08	9.43	—	—	295.35	7.04	—	—	307.08	5.31	—	—

LEGEND

Cap. — Capacity (Tons)
 EFT — Entering Fluid Temperature
 LFT — Leaving Fluid Temperature
 LTD — Leaving Temperature Difference
 PD — Pressure Drop (psig)
 SET — Refrigerant Saturated Evaporator Temperature

NOTES:

- Fouling factor is 0.0005.
- Shaded selections are 2-pass. All other selections are 4-pass.
- LTD = LFT - SET
- Range = EFT - LFT



BRINE RATINGS — R-22 (cont)
0° F SET, ETHYLENE GLYCOL SOLUTION (40%)

UNIT 10RT	6 F RANGE				8 F RANGE				10 F RANGE				12 F RANGE			
	8 F LTD		10 F LTD		8 F LTD		10 F LTD		8 F LTD		10 F LTD		8 F LTD		10 F LTD	
	Cap.	PD	Cap.	PD	Cap.	PD	Cap.	PD	Cap.	PD	Cap.	PD	Cap.	PD	Cap.	PD
0401-A	—	—	2.06	1.11	—	—	1.97	0.87	—	—	—	—	—	—	—	—
0501-A	2.25	1.66	4.09	4.34	2.25	1.09	3.49	2.02	2.24	0.90	3.48	1.42	2.15	0.77	3.46	1.11
0501-B	5.42	4.13	8.12	8.94	5.03	2.28	7.75	4.62	5.05	1.58	6.97	2.61	5.04	1.16	6.97	1.93
0401-C	—	—	6.58	1.44	—	—	6.56	1.04	—	—	6.15	0.84	—	—	6.13	0.75
0501-C	6.91	1.98	12.54	5.70	7.18	1.36	11.97	2.96	7.21	1.06	10.74	1.71	7.21	0.91	10.51	1.24
0602-C	8.36	1.84	13.16	3.88	8.36	1.16	11.96	2.00	8.35	0.96	11.67	1.33	8.05	0.82	11.62	1.08
0702-C	11.35	3.41	17.11	7.52	10.73	1.97	16.27	3.89	10.74	1.37	14.50	2.17	10.75	1.09	14.55	1.62
0704-D	12.04	1.02	17.93	1.72	11.96	0.82	17.24	1.08	11.65	0.71	16.60	0.87	11.32	0.65	16.00	0.76
0804-D	15.25	1.52	21.40	2.63	14.94	1.02	20.66	1.51	14.59	0.85	19.95	1.07	14.54	0.75	19.90	0.92
0904-D	17.26	2.27	32.88	6.98	17.28	1.39	31.03	3.64	17.31	1.06	27.64	2.06	17.34	0.91	26.86	1.43
0804-E	23.45	2.04	37.46	4.50	23.40	1.26	32.69	2.18	23.30	1.01	31.63	1.41	22.84	0.86	31.57	1.10
1004-F	47.29	4.96	70.89	10.02	44.11	2.71	70.30	5.96	44.23	1.84	67.49	3.72	44.24	1.35	61.60	2.33
1104-G	64.42	5.32	94.78	10.49	64.37	3.21	94.56	6.20	60.68	1.98	92.75	4.01	60.86	1.44	90.99	2.80
1003-H	93.76	8.62	—	—	96.05	5.36	135.61	9.87	98.14	3.76	135.68	6.55	98.14	2.73	135.78	4.70
1003-J	116.52	7.65	—	—	121.47	4.96	169.00	8.76	121.85	3.33	168.89	5.81	112.93	2.13	168.87	4.17
0601-B	5.42	4.13	8.12	8.94	5.03	2.28	7.75	4.62	5.05	1.58	6.97	2.61	5.04	1.16	6.97	1.93
0503-D	11.33	1.25	18.18	2.59	11.28	0.95	16.49	1.39	10.80	0.79	15.92	1.03	10.76	0.71	15.81	0.89
0604-D	8.52	0.75	13.65	1.04	8.21	0.65	13.01	0.81	—	—	12.44	0.70	—	—	11.87	0.64
0702-D	15.65	2.96	23.94	6.35	15.95	1.93	22.60	3.27	15.92	1.34	20.74	1.97	15.92	1.07	20.75	1.46
0806-E	17.64	1.07	25.76	1.87	17.01	0.83	24.55	1.11	16.44	0.71	23.42	0.88	16.31	0.65	22.35	0.76
1104-F	57.47	8.00	81.15	14.79	57.28	4.82	79.55	8.44	52.79	2.83	76.93	5.26	53.98	2.16	76.52	3.82
1104-G	77.97	8.83	107.24	15.45	78.24	5.27	107.07	9.08	78.22	3.56	106.98	6.06	73.97	2.38	106.93	4.37
0903-H	76.36	5.16	114.73	10.62	76.52	3.10	114.78	6.25	72.17	1.91	114.60	4.17	72.62	1.40	111.09	2.82
1205-H	102.28	6.74	140.82	11.84	102.25	4.05	138.54	6.76	96.66	2.51	138.03	4.53	96.92	1.82	135.79	3.17
1104-J	126.95	6.55	177.93	11.97	127.33	3.91	177.59	7.03	127.34	2.64	177.38	4.68	120.57	1.77	177.27	3.37
1204-J	144.84	9.94	192.78	16.70	148.10	6.15	193.43	9.78	148.26	4.13	196.04	6.71	150.88	3.12	196.62	4.82
0902-L	142.93	4.76	—	—	147.45	2.97	217.40	5.90	154.79	2.18	224.15	4.17	161.50	1.72	224.84	2.98
1002-L	179.04	8.68	—	—	187.94	5.56	257.50	9.72	196.15	4.01	265.01	6.81	197.33	2.89	272.58	5.14
1103-L	192.67	9.87	—	—	201.88	6.36	272.04	10.84	206.68	4.42	276.83	7.39	211.14	3.32	281.59	5.45
1203-L	219.47	12.59	—	—	229.47	8.04	295.66	12.68	234.99	5.56	301.84	8.63	240.40	4.15	307.81	6.35

-20 F SET, ETHYLENE GLYCOL SOLUTION (50%)

UNIT 10RT	6 F RANGE				8 F RANGE				10 F RANGE				12 F RANGE			
	8 F LTD		10 F LTD		8 F LTD		10 F LTD		8 F LTD		10 F LTD		8 F LTD		10 F LTD	
	Cap.	PD	Cap.	PD	Cap.	PD	Cap.	PD	Cap.	PD	Cap.	PD	Cap.	PD	Cap.	PD
0401-A	—	—	—	—	—	—	—	—	—	—	—	—	—	—	—	—
0501-A	—	—	2.04	2.15	—	—	—	—	—	—	—	—	—	—	—	—
0501-B	—	—	4.37	4.40	—	—	4.07	2.37	—	—	3.70	1.35	—	—	3.50	1.02
0401-C	—	—	—	—	—	—	—	—	—	—	—	—	—	—	—	—
0501-C	—	—	6.60	3.16	—	—	6.02	1.71	—	—	5.71	1.10	—	—	5.41	0.93
0602-C	—	—	7.28	2.40	—	—	6.74	1.34	—	—	6.37	0.99	—	—	6.00	0.83
0702-C	6.40	2.33	9.00	3.85	6.02	1.31	8.58	2.24	5.97	1.02	8.18	1.44	5.76	0.87	8.11	1.12
0704-D	—	—	10.03	1.10	—	—	9.30	0.83	—	—	8.99	0.73	—	—	8.96	0.68
0804-D	8.45	1.03	12.30	1.62	8.24	0.83	11.51	1.03	8.39	0.75	11.05	0.84	8.40	0.69	10.74	0.75
0904-D	10.34	1.56	16.50	3.18	9.92	1.02	13.18	1.40	9.74	0.87	12.76	1.03	9.91	0.79	12.50	0.88
0804-E	13.48	1.30	19.35	2.27	12.85	0.94	18.17	1.28	12.89	0.82	17.49	0.98	12.91	0.75	16.69	0.83
1004-F	28.02	3.60	41.38	6.10	21.30	1.72	39.72	3.70	20.98	1.28	38.24	2.52	20.69	1.01	36.77	1.84
1004-G	39.62	3.85	57.06	6.45	37.95	2.35	55.10	3.85	37.83	1.71	53.28	2.59	28.93	0.98	52.88	1.96
1003-H	58.40	5.90	84.10	10.47	58.28	3.74	81.95	6.11	56.47	2.50	79.76	4.04	56.30	1.91	79.37	3.01
1003-J	72.50	5.24	104.54	9.24	72.34	3.33	101.81	5.42	72.30	2.37	101.18	3.76	69.89	1.71	98.59	2.68
0601-B	—	—	4.37	4.40	—	—	4.07	2.37	—	—	3.70	1.35	—	—	3.50	1.02
0503-D	—	—	9.67	1.55	—	—	9.03	1.01	—	—	8.23	0.80	—	—	8.19	0.74
0604-D	—	—	—	—	—	—	—	—	—	—	—	—	—	—	—	—
0702-D	9.28	2.18	13.33	3.72	8.67	1.20	12.64	2.15	8.34	0.96	12.00	1.38	8.33	0.85	11.63	1.06
0806-E	—	—	14.61	1.07	—	—	14.01	0.84	—	—	13.75	0.74	—	—	13.50	0.67
1104-F	33.63	5.31	48.04	8.82	33.36	3.48	46.38	5.29	32.01	2.39	44.74	3.57	31.80	1.86	43.24	2.59
1104-G	47.29	5.88	66.13	9.65	46.37	3.66	64.18	5.70	45.51	2.55	63.65	3.99	45.30	1.96	61.87	2.86
0903-H	39.28	2.78	70.20	6.60	38.81	1.79	68.01	3.90	38.40	1.29	66.04	2.60	38.35	1.01	63.99	1.87
1205-H	62.23	4.75	86.22	7.47	60.90	3.01	83.45	4.49	60.69	2.19	82.68	3.19	58.33	1.61	80.27	2.31
1104-J	77.68	4.46	110.66	7.62	76.26	2.78	107.68	4.52	76.17	2.00	104.68	3.02	75.86	1.54	101.90	2.18
1204-J	89.53	6.66	122.18	10.72	89.46	4.23	120.13	6.47	89.29	3.01	117.36	4.30	87.86	2.23	117.01	3.21
0902-L	93.15	3.46	139.34	6.59	96.38	2.33	139.10	4.02	96.70	1.64	138.99	2.76	96.82	1.24	138.66	2.05
1002-L	115.84	5.95	163.38	10.24	119.57	3.91	166.67	6.58	120.16	2.72	163.41	4.28	120.25	2.04	163.34	3.15
1103-L	126.31	7.12	173.87	11.76	126.84	4.46	173.47	7.17	127.22	3.13	173.16	4.92	127.27	2.36	173.14	3.64
1203-L	142.98	8.68	189.51	13.52	147.45	5.69	189.53	8.25	147.73	3.96	189.76	5.64	148.15	2.96	193.37	4.33

LEGEND

Cap. — Capacity (Tons) LTD — Leaving Temperature Difference
EFT — Entering Fluid Temperature PD — Pressure Drop (psig)
LFT — Leaving Fluid Temperature SET — Refrigerant Saturated Evaporator Temperature

NOTES:

- Fouling factor is 0.0005.
- Shaded selections are 2-pass. All other selections are 4-pass.
- LTD = LFT - SET
- Range = EFT - LFT

Performance data (cont)



BRINE RATINGS — R-134a 20 F SET, ETHYLENE GLYCOL SOLUTION (20%)

UNIT 10RT	6 F RANGE				8 F RANGE				10 F RANGE				12 F RANGE			
	8 F LTD		10 F LTD		8 F LTD		10 F LTD		8 F LTD		10 F LTD		8 F LTD		10 F LTD	
	Cap.	PD	Cap.	PD	Cap.	PD	Cap.	PD	Cap.	PD	Cap.	PD	Cap.	PD	Cap.	PD
0401-A	2.36	1.04	3.95	2.48	2.38	0.81	4.09	1.53	2.52	0.73	4.10	1.08	2.53	0.66	4.10	0.90
0501-A	3.89	3.08	5.41	5.88	4.10	1.94	5.53	3.48	4.28	1.38	5.71	2.41	4.31	1.06	5.83	1.75
0501-B	7.09	5.40	9.72	9.99	7.40	3.32	10.83	7.09	7.75	2.37	11.61	5.24	7.98	1.74	11.70	3.66
0401-C	7.06	1.15	11.32	2.87	7.54	0.94	11.78	1.78	8.01	0.82	12.19	1.24	8.43	0.75	12.25	1.01
0501-C	10.84	3.30	14.62	6.00	11.66	2.20	15.06	3.56	12.04	1.50	15.63	2.49	12.60	1.15	16.20	1.88
0602-C	11.95	2.57	16.78	4.91	12.38	1.56	18.22	3.29	12.78	1.12	19.64	2.48	13.17	0.96	20.39	1.86
0702-C	14.54	4.31	24.04	11.53	16.28	3.05	25.79	7.44	17.99	2.40	27.40	5.45	18.90	1.84	28.32	4.05
0704-D	17.70	1.22	29.26	3.24	18.04	0.92	29.42	1.85	18.57	0.79	30.65	1.31	18.69	0.71	30.68	1.04
0804-D	23.06	2.31	38.26	6.18	25.26	1.59	39.77	3.82	26.15	1.14	39.96	2.48	27.55	1.00	41.30	1.87
0904-D	31.04	5.03	44.90	10.25	32.90	3.20	46.52	6.31	34.56	2.30	47.57	4.24	36.16	1.78	48.58	3.09
0804-E	37.34	3.62	58.81	8.51	39.79	2.34	62.91	5.67	42.17	1.70	63.29	3.70	44.32	1.33	65.39	2.79
1004-F	64.98	6.18	83.66	10.15	68.97	4.04	86.72	6.22	70.93	2.75	89.70	4.31	73.74	2.10	92.62	3.23
1004-G	83.25	6.07	107.60	9.98	88.89	3.96	111.98	6.10	92.92	2.80	117.20	4.36	98.05	2.21	121.36	3.26
1003-H	112.63	8.87	144.62	14.54	121.57	5.93	152.03	9.10	128.61	4.29	159.25	6.43	135.51	3.35	166.33	4.91
1003-J	144.37	8.53	—	—	153.81	5.46	193.80	8.57	162.56	3.95	202.81	6.04	171.15	3.07	211.65	4.60
0601-B	7.09	5.40	9.72	9.99	7.40	3.32	10.83	7.09	7.75	2.37	11.61	5.24	7.98	1.74	11.70	3.66
0503-D	17.56	1.90	22.77	3.11	18.10	1.15	24.92	2.14	18.63	0.96	26.07	1.51	18.78	0.82	27.17	1.15
0604-D	15.26	0.96	20.66	1.42	15.31	0.77	20.68	0.98	15.29	0.67	20.87	0.82	14.20	0.61	20.89	0.72
0702-D	21.24	3.98	35.89	11.12	23.89	2.86	37.48	6.75	25.38	2.06	39.94	5.00	26.75	1.59	41.31	3.73
0806-E	25.79	1.44	46.91	4.32	25.85	1.00	46.86	2.54	25.09	0.82	46.80	1.69	25.71	0.74	46.64	1.21
1104-F	71.42	8.61	87.71	12.64	74.80	5.38	91.27	7.75	78.07	3.80	95.33	5.56	81.26	2.90	—	—
1104-G	91.03	8.38	113.35	12.87	96.85	5.46	119.22	8.15	101.44	3.85	124.12	5.65	107.03	3.04	—	—
0903-H	98.19	5.83	132.30	10.36	106.75	3.93	140.02	6.68	114.46	2.96	145.18	4.59	119.21	2.24	152.73	3.60
1205-H	121.57	6.59	149.11	9.74	127.62	4.13	155.57	5.99	133.45	2.92	—	—	140.56	2.32	—	—
1104-J	152.15	6.68	189.67	10.26	161.45	4.30	199.17	6.44	170.54	3.12	208.44	4.57	177.72	2.36	216.14	3.40
1204-J	161.53	9.00	196.24	13.05	171.71	5.81	206.61	8.23	180.82	4.15	—	—	189.68	3.20	—	—
0902-L	173.85	5.04	—	—	193.07	3.53	254.06	6.03	208.23	2.66	266.84	4.26	220.35	2.08	279.38	3.24
1002-L	201.17	8.01	—	—	221.62	5.57	277.87	8.56	235.54	4.02	292.30	6.05	249.18	3.13	308.64	4.74
1103-L	216.17	9.09	271.89	14.22	233.95	6.11	287.30	8.95	248.55	4.44	304.33	6.55	262.85	3.47	319.04	5.02
1203-L	230.74	10.26	—	—	249.35	6.92	300.63	9.89	265.19	5.03	—	—	280.66	3.94	—	—

10 F SET, ETHYLENE GLYCOL SOLUTION (30%)

UNIT 10RT	6 F RANGE				8 F RANGE				10 F RANGE				12 F RANGE			
	8 F LTD		10 F LTD		8 F LTD		10 F LTD		8 F LTD		10 F LTD		8 F LTD		10 F LTD	
	Cap.	PD	Cap.	PD	Cap.	PD	Cap.	PD	Cap.	PD	Cap.	PD	Cap.	PD	Cap.	PD
0401-A	—	—	3.00	1.63	—	—	2.85	0.99	—	—	2.60	0.79	—	—	2.60	0.72
0501-A	2.97	2.03	4.28	4.17	3.06	1.24	4.28	2.38	2.77	0.91	4.28	1.54	2.87	0.82	4.28	1.13
0501-B	5.61	3.82	7.80	7.16	5.65	2.17	8.50	4.91	5.80	1.50	8.55	3.17	5.83	1.12	8.56	2.21
0401-C	5.20	0.91	8.94	2.04	4.96	0.74	8.93	1.17	5.20	0.68	8.72	0.92	5.42	0.65	8.50	0.78
0501-C	8.68	2.42	11.69	4.30	8.97	1.48	11.94	2.58	9.00	1.06	12.02	1.67	9.04	0.90	12.27	1.23
0602-C	9.28	1.74	13.80	3.77	9.43	1.10	13.86	2.15	9.46	0.90	14.52	1.54	9.14	0.78	14.54	1.13
0702-C	11.94	3.29	19.76	8.64	12.80	2.15	20.60	5.36	12.91	1.39	21.34	3.75	13.70	1.11	21.41	2.63
0704-D	13.34	0.97	21.42	1.94	12.98	0.78	21.31	1.11	13.03	0.69	21.22	0.93	13.30	0.64	18.74	0.75
0804-D	17.61	1.53	29.87	4.23	18.29	1.06	29.24	2.31	16.90	0.83	29.13	1.50	17.61	0.76	29.03	1.11
0904-D	24.12	3.43	35.55	7.15	24.26	1.97	35.55	4.10	24.32	1.28	36.16	2.79	22.59	0.98	36.18	1.96
0804-E	28.06	2.30	46.86	6.12	28.14	1.33	46.88	3.52	26.88	0.99	46.74	2.29	27.99	0.89	46.62	1.62
1004-F	54.31	5.13	69.25	7.97	55.67	3.17	70.58	4.82	55.97	2.11	71.90	3.31	57.20	1.59	73.22	2.45
1004-G	70.28	5.01	90.81	8.11	73.64	3.23	93.02	4.89	75.59	2.25	95.13	3.34	77.50	1.68	98.23	2.56
1003-H	98.04	7.79	123.55	12.07	102.61	4.94	128.25	7.47	105.64	3.39	131.70	5.06	109.97	2.62	136.16	3.83
1003-J	124.31	7.23	156.77	11.11	130.04	4.57	162.52	6.86	133.76	3.14	168.14	4.80	139.11	2.42	173.68	3.62
0601-B	5.61	3.82	7.80	7.16	5.65	2.17	8.50	4.91	5.80	1.50	8.55	3.17	5.83	1.12	8.56	2.21
0503-D	13.32	1.23	18.13	2.24	12.51	0.88	18.13	1.28	12.78	0.77	18.13	0.98	13.04	0.71	16.93	0.82
0604-D	10.48	0.77	15.58	1.03	10.50	0.67	14.45	0.78	10.50	0.61	14.23	0.68	10.49	0.58	14.20	0.64
0702-D	16.64	2.74	29.25	8.24	17.37	1.69	29.42	4.70	18.63	1.26	30.56	3.31	18.70	1.03	30.60	2.32
0806-E	18.80	1.03	33.93	2.61	18.78	0.82	29.29	1.20	18.80	0.72	29.25	0.97	19.03	0.66	29.20	0.84
1104-F	58.87	6.81	72.61	9.96	60.48	4.19	74.72	6.15	62.03	2.92	76.48	4.22	63.56	2.19	78.16	3.13
1104-G	76.64	6.88	95.13	10.30	80.20	4.43	98.76	6.47	82.60	3.07	101.48	4.42	84.91	2.30	104.99	3.39
0903-H	85.37	5.10	114.71	8.94	89.82	3.26	118.63	5.53	93.62	2.34	121.28	3.75	95.94	1.75	123.83	2.75
1205-H	100.87	5.31	123.56	7.64	103.93	3.28	127.50	4.73	107.57	2.34	131.34	3.31	110.43	1.76	135.12	2.51
1104-J	128.41	5.50	159.11	8.14	133.26	3.43	164.94	5.07	137.07	2.37	170.68	3.57	142.57	1.84	174.90	2.63
1204-J	135.01	7.16	164.52	10.55	141.41	4.58	170.88	6.47	147.66	3.30	177.37	4.57	152.14	2.46	183.14	3.42
0902-L	155.32	4.55	—	—	169.89	3.16	220.27	5.12	177.86	2.26	230.82	3.69	185.69	1.74	239.01	2.77
1002-L	179.64	7.28	—	—	192.02	4.79	239.56	7.22	201.27	3.41	249.30	5.03	210.29	2.61	260.90	3.91
1103-L	188.06	7.86	234.01	11.97	197.92	4.99	244.42	7.43	207.48	3.58	254.46	5.21	216.83	2.77	266.26	4.09
1203-L	199.03	8.79	240.91	12.50	210.10	5.59	253.25	7.94	221.88	4.10	265.24	5.70	232.29	3.17	—	—

LEGEND

Cap. — Capacity (Tons)
 EFT — Entering Fluid Temperature
 LFT — Leaving Fluid Temperature
 LTD — Leaving Temperature Difference
 PD — Pressure Drop (psig)
 SET — Refrigerant Saturated Evaporator Temperature

NOTES:

- Fouling factor is 0.0005.
- Shaded selections are 2-pass. All other selections are 4-pass.
- LTD = LFT - SET
- Range = EFT - LFT



BRINE RATINGS — R-134a (cont)
0° F SET, ETHYLENE GLYCOL SOLUTION (40%)

UNIT 10RT	6 F RANGE				8 F RANGE				10 F RANGE				12 F RANGE			
	8 F LTD		10 F LTD		8 F LTD		10 F LTD		8 F LTD		10 F LTD		8 F LTD		10 F LTD	
	Cap.	PD	Cap.	PD	Cap.	PD	Cap.	PD	Cap.	PD	Cap.	PD	Cap.	PD	Cap.	PD
0401-A	—	—	1.97	1.11	—	—	1.89	0.85	—	—	—	—	—	—	—	—
0501-A	2.04	1.43	2.92	2.44	2.04	1.01	2.88	1.49	2.00	0.83	2.86	1.10	1.95	0.73	2.85	0.94
0501-B	3.89	2.39	5.80	4.63	3.98	1.57	5.13	2.30	3.98	1.12	5.41	1.74	3.98	0.95	5.43	1.30
0401-C	—	—	5.88	1.21	—	—	5.88	0.96	—	—	5.67	0.80	—	—	5.64	0.72
0501-C	5.98	1.60	8.70	2.78	6.14	1.13	8.25	1.62	6.15	0.93	8.36	1.18	6.27	0.84	8.39	1.02
0602-C	6.55	1.25	8.57	1.86	6.57	0.95	8.57	1.18	6.57	0.82	8.58	0.97	6.57	0.73	8.70	0.86
0702-C	7.51	1.78	14.59	5.48	7.68	1.16	14.53	3.13	7.74	0.97	13.28	1.88	7.93	0.86	13.30	1.40
0704-D	9.62	0.86	12.50	1.04	9.36	0.71	12.33	0.83	9.32	0.65	12.28	0.73	9.30	0.61	12.05	0.66
0804-D	10.72	0.99	19.18	2.18	10.73	0.80	19.10	1.34	10.76	0.71	18.46	1.00	10.90	0.66	18.38	0.87
0904-D	15.60	1.91	25.87	4.42	16.00	1.22	23.47	2.27	16.40	1.01	23.37	1.55	16.40	0.88	23.32	1.14
0804-E	16.63	1.16	32.68	3.54	16.69	0.92	29.36	1.79	16.92	0.80	29.31	1.23	16.99	0.72	29.21	1.03
1004-F	38.27	3.48	53.71	6.14	39.00	2.19	52.91	3.62	39.53	1.54	50.19	2.24	39.63	1.13	50.27	1.62
1004-G	54.85	4.03	71.96	6.39	52.90	2.31	71.91	3.82	53.20	1.58	71.88	2.59	54.73	1.22	69.74	1.81
1003-H	77.47	6.11	99.42	9.51	79.33	3.86	100.72	5.75	75.26	2.37	102.58	4.01	77.48	1.82	103.17	2.90
1003-J	98.53	5.72	126.29	8.81	99.01	3.43	127.77	5.32	95.63	2.21	129.99	3.70	98.36	1.70	130.62	2.68
0601-B	3.89	2.39	5.80	4.63	3.98	1.57	5.13	2.30	3.98	1.12	5.41	1.74	3.98	0.95	5.43	1.30
0503-D	9.32	1.03	12.69	1.48	9.32	0.83	12.45	1.02	9.09	0.72	12.22	0.85	9.07	0.66	12.20	0.76
0604-D	—	—	11.02	0.88	—	—	10.49	0.72	—	—	10.18	0.64	—	—	9.91	0.60
0702-D	11.32	1.77	21.23	5.05	11.38	1.11	18.66	2.40	11.63	0.97	18.74	1.68	11.69	0.85	18.72	1.25
0806-E	13.98	0.89	18.08	1.10	13.51	0.72	17.61	0.84	13.42	0.65	17.50	0.73	13.17	0.61	17.26	0.67
1104-F	44.78	5.17	56.69	7.70	43.14	2.97	56.67	4.63	43.83	2.08	54.46	2.93	44.57	1.57	55.64	2.24
1104-G	60.63	5.64	75.98	8.31	57.91	3.13	76.53	4.96	59.70	2.27	77.94	3.51	60.86	1.70	75.30	2.39
0903-H	68.00	4.19	91.83	7.00	68.32	2.54	91.79	4.16	66.05	1.64	91.78	2.80	67.96	1.27	93.19	2.11
1205-H	77.65	4.15	97.12	6.02	76.08	2.45	98.06	3.72	77.49	1.72	95.63	2.41	78.94	1.30	97.17	1.79
1104-J	101.19	4.41	126.92	6.47	101.46	2.66	128.42	3.94	98.57	1.72	129.87	2.71	101.35	1.32	125.35	1.85
1204-J	106.87	5.78	131.07	8.20	108.70	3.58	134.07	5.11	106.83	2.37	136.35	3.51	110.14	1.83	138.44	2.61
0902-L	131.01	4.09	174.65	6.73	135.50	2.57	178.30	4.12	138.97	1.82	181.94	2.86	134.89	1.26	185.58	2.14
1002-L	149.43	6.22	188.72	9.36	154.07	3.88	194.69	5.84	158.44	2.73	200.59	4.12	162.74	2.07	205.33	3.07
1103-L	152.90	6.48	190.64	9.55	157.48	4.08	196.67	6.02	161.94	2.90	201.65	4.19	159.39	2.06	206.48	3.15
1203-L	161.33	7.14	196.54	10.17	168.08	4.61	203.73	6.42	173.52	3.27	209.91	4.47	178.78	2.49	216.70	3.43

-10 F SET, ETHYLENE GLYCOL SOLUTION (50%)

UNIT 10RT	6 F RANGE				8 F RANGE				10 F RANGE				12 F RANGE			
	8 F LTD		10 F LTD		8 F LTD		10 F LTD		8 F LTD		10 F LTD		8 F LTD		10 F LTD	
	Cap.	PD	Cap.	PD	Cap.	PD	Cap.	PD	Cap.	PD	Cap.	PD	Cap.	PD	Cap.	PD
0401-A	—	—	—	—	—	—	—	—	—	—	—	—	—	—	—	—
0501-A	—	—	2.05	1.91	—	—	1.95	1.13	—	—	1.84	0.89	—	—	1.74	0.76
0501-B	2.73	1.79	3.79	3.12	2.71	1.13	3.69	1.80	2.61	0.90	3.59	1.17	—	—	3.50	0.97
0401-C	—	—	—	—	—	—	—	—	—	—	—	—	—	—	—	—
0501-C	—	—	6.16	2.45	—	—	5.99	1.48	—	—	5.83	1.08	—	—	5.69	0.91
0602-C	—	—	6.36	1.69	—	—	6.18	1.09	—	—	6.01	0.89	—	—	5.85	0.78
0702-C	5.55	1.60	9.47	3.60	5.47	1.07	9.41	2.26	5.46	0.90	6.96	1.07	5.46	0.79	6.96	0.92
0704-D	—	—	9.02	0.95	—	—	8.66	0.76	—	—	8.33	0.67	—	—	8.30	0.63
0804-D	10.53	0.93	11.03	1.73	10.17	0.75	9.72	0.86	7.48	0.67	9.57	0.74	7.65	0.64	9.53	0.68
0904-D	12.17	1.46	17.30	3.06	11.74	1.03	16.48	1.74	11.43	0.84	16.01	1.15	11.19	0.75	15.56	0.98
0804-E	16.16	1.12	16.93	2.31	15.62	0.86	15.07	0.99	11.68	0.73	14.93	0.83	11.75	0.68	14.89	0.74
1004-F	28.76	3.09	38.88	4.85	28.68	2.00	38.07	2.95	28.02	1.39	36.92	1.96	27.91	1.08	36.76	1.49
1004-G	39.69	3.27	52.80	5.09	39.76	2.08	51.99	3.05	39.66	1.48	51.27	2.06	39.62	1.12	51.20	1.55
1003-H	56.32	4.84	72.85	7.26	57.29	3.10	72.88	4.44	57.35	2.16	72.96	3.04	57.47	1.62	73.80	2.30
1003-J	71.09	4.43	92.71	6.78	72.32	2.84	92.69	4.14	72.38	1.98	92.77	2.84	72.52	1.48	92.94	2.09
0601-B	2.73	1.79	3.79	3.12	2.71	1.13	3.69	1.80	2.61	0.90	3.59	1.17	—	—	3.50	0.97
0503-D	—	—	9.09	1.22	—	—	8.76	0.93	—	—	8.46	0.78	—	—	8.19	0.69
0604-D	—	—	7.61	0.80	—	—	—	—	—	—	—	—	—	—	—	—
0702-D	8.30	1.57	10.53	2.22	8.15	1.06	10.47	1.39	8.00	0.87	10.35	1.05	7.98	0.77	10.33	0.91
0806-E	15.43	0.73	16.08	1.02	14.96	0.66	12.32	0.74	—	—	12.32	0.67	—	—	12.35	0.63
1104-F	32.61	4.32	41.45	6.13	32.04	2.66	41.27	3.82	31.94	1.91	40.76	2.60	31.91	1.46	40.72	1.96
1104-G	44.30	4.56	55.87	6.48	44.33	2.87	55.86	3.98	44.37	2.02	56.48	2.84	44.46	1.53	56.64	2.12
0903-H	48.93	3.31	67.08	5.46	49.05	2.07	66.04	3.24	49.05	1.46	65.83	2.23	49.00	1.10	65.74	1.65
1205-H	57.86	3.61	72.05	4.93	57.01	2.23	72.02	3.08	57.00	1.60	72.10	2.16	57.95	1.26	72.24	1.63
1104-J	73.20	3.47	93.54	5.10	73.32	2.19	93.55	3.14	74.37	1.59	93.70	2.18	74.54	1.21	94.83	1.66
1204-J	79.16	4.76	97.77	6.64	79.55	2.98	98.46	4.07	80.92	2.16	99.88	2.89	82.38	1.68	101.40	2.21
0902-L	96.72	3.26	131.04	5.32	100.36	2.14	131.53	3.27	100.82	1.48	131.91	2.22	103.89	1.16	134.81	1.71
1002-L	111.23	4.97	147.30	7.79	115.03	3.24	144.89	4.65	115.90	2.22	147.37	3.26	119.47	1.74	149.70	2.43
1103-L	115.05	5.37	143.39	7.59	117.27	3.42	145.84	4.76	119.59	2.44	148.26	3.34	121.97	1.87	150.75	2.52
1203-L	122.30	5.98	148.63	8.03	125.26	3.79	152.92	5.21	128.19	2.70	156.20	3.64	132.45	2.13	160.49	2.81

LEGEND

Cap. — Capacity (Tons) LTD — Leaving Temperature Difference
EFT — Entering Fluid Temperature PD — Pressure Drop (psig)
LFT — Leaving Fluid Temperature SET — Refrigerant Saturated Evaporator Temperature

NOTES:

- Fouling factor is 0.0005.
- Shaded selections are 2-pass. All other selections are 4-pass.
- LTD = LFT – SET
- Range = EFT – LFT

Performance data (cont)



BRINE RATINGS — R-507/404A 20 F SET, ETHYLENE GLYCOL SOLUTION (20%)

UNIT 10RT	6 F RANGE				8 F RANGE				10 F RANGE				12 F RANGE			
	8 F LTD		10 F LTD		8 F LTD		10 F LTD		8 F LTD		10 F LTD		8 F LTD		10 F LTD	
	Cap.	PD	Cap.	PD	Cap.	PD	Cap.	PD	Cap.	PD	Cap.	PD	Cap.	PD	Cap.	PD
0401-A	3.15	1.61	5.36	4.53	3.17	1.04	5.37	2.58	3.31	0.88	5.38	1.67	3.46	0.79	5.37	1.17
0501-A	5.31	5.68	5.31	5.67	5.54	3.48	5.73	3.73	5.73	2.42	6.14	2.76	5.91	1.81	6.55	2.19
0501-B	6.99	5.25	—	—	7.80	3.67	14.04	11.66	8.94	3.12	15.50	9.21	10.06	2.77	16.26	7.08
0401-C	9.44	2.02	15.53	5.36	10.33	1.39	16.02	3.23	10.81	1.07	16.08	2.09	11.25	0.93	16.48	1.55
0501-C	15.01	6.25	15.66	6.76	16.14	4.14	17.99	5.08	16.73	2.88	19.26	3.73	17.31	2.16	21.54	3.29
0602-C	11.68	2.42	23.23	9.45	13.16	1.74	24.73	6.00	14.62	1.38	26.20	4.34	16.05	1.17	27.60	3.38
0702-C	19.68	7.77	—	—	22.24	5.63	—	—	24.03	4.21	37.53	10.26	25.72	3.37	37.83	7.12
0704-D	21.25	1.75	38.67	5.52	22.59	1.13	39.94	3.38	23.89	0.98	40.07	2.19	24.01	0.84	40.12	1.54
0804-D	32.06	4.42	—	—	33.70	2.77	53.57	6.79	35.28	1.96	54.94	4.65	36.72	1.50	55.08	3.27
0904-D	41.56	8.77	62.04	19.51	44.89	5.87	62.58	11.04	46.69	4.10	—	—	48.29	3.09	—	—
0804-E	49.23	6.09	—	—	53.75	4.18	84.18	9.88	56.22	2.95	84.59	6.42	58.46	2.25	86.64	4.76
1004-F	76.32	8.53	—	—	82.01	5.65	—	—	85.13	3.93	—	—	88.05	2.96	—	—
1004-G	94.82	7.77	129.12	14.07	102.58	5.17	—	—	109.71	3.86	—	—	113.83	2.90	—	—
1003-H	130.72	11.96	—	—	141.11	7.81	—	—	150.47	5.74	—	—	159.36	4.54	—	—
1003-J	162.95	10.63	—	—	179.88	7.40	—	—	191.55	5.41	—	—	202.59	4.26	—	—
0601-B	6.99	5.25	—	—	7.80	3.67	14.04	11.66	8.94	3.12	15.50	9.21	10.06	2.77	16.26	7.08
0503-D	24.31	3.58	31.69	5.99	24.89	2.14	33.88	3.91	25.03	1.38	34.11	2.53	20.41	0.88	36.22	2.01
0604-D	20.46	1.38	24.88	2.04	20.48	0.96	24.91	1.17	20.42	0.80	24.94	0.94	20.34	0.71	24.95	0.81
0702-D	28.03	6.77	—	—	31.93	5.01	50.79	12.40	34.63	3.79	53.43	8.79	37.20	3.06	55.84	6.75
0806-E	35.02	2.55	63.15	7.52	35.07	1.50	61.08	4.12	35.09	1.08	60.95	2.73	35.10	0.92	60.71	1.95
1104-F	86.09	12.24	—	—	92.05	8.05	—	—	95.49	5.59	—	—	—	—	—	—
1104-G	109.07	12.01	—	—	117.46	7.91	—	—	123.59	5.67	—	—	128.32	4.25	—	—
0903-H	110.19	7.39	—	—	119.37	4.88	165.40	9.24	128.21	3.62	170.75	6.28	136.19	2.89	178.80	4.85
1205-H	148.90	9.78	—	—	157.59	6.22	—	—	—	—	—	—	—	—	—	—
1104-J	178.29	9.00	—	—	195.80	6.27	—	—	203.54	4.33	—	—	215.09	3.42	—	—
1204-J	199.24	13.54	—	—	—	—	—	—	—	—	—	—	—	—	—	—
0902-L	186.03	5.71	—	—	209.35	4.10	—	—	232.16	3.26	309.49	5.67	247.69	2.59	325.34	4.37
1002-L	—	—	—	—	255.74	7.35	—	—	274.23	5.39	—	—	291.60	4.26	—	—
1103-L	252.84	12.41	—	—	280.40	8.69	—	—	299.03	6.38	—	—	314.43	4.89	—	—
1203-L	—	—	—	—	305.71	10.25	—	—	—	—	—	—	—	—	—	—

10 F SET, ETHYLENE GLYCOL SOLUTION (30%)

UNIT 10RT	6 F RANGE				8 F RANGE				10 F RANGE				12 F RANGE			
	8 F LTD		10 F LTD		8 F LTD		10 F LTD		8 F LTD		10 F LTD		8 F LTD		10 F LTD	
	Cap.	PD	Cap.	PD	Cap.	PD	Cap.	PD	Cap.	PD	Cap.	PD	Cap.	PD	Cap.	PD
0401-A	2.20	1.03	3.95	2.78	1.97	0.77	3.79	1.47	2.05	0.70	3.63	1.01	2.06	0.65	3.15	0.79
0501-A	4.07	3.80	5.92	7.82	4.08	2.17	5.82	4.31	4.08	1.40	5.73	2.69	3.90	1.03	5.71	1.89
0501-B	7.76	7.17	10.84	13.83	7.79	4.08	10.89	7.87	7.80	2.63	11.26	5.44	7.94	1.93	11.62	4.06
0401-C	7.06	1.29	12.19	3.76	7.06	0.93	11.80	1.99	6.36	0.75	11.76	1.29	6.60	0.70	11.32	0.99
0501-C	11.95	4.53	13.15	5.44	12.28	2.71	13.24	3.11	12.29	1.76	14.37	2.38	12.53	1.29	14.44	1.67
0602-C	12.79	3.22	18.19	6.43	13.05	1.94	18.86	3.96	13.04	1.26	18.90	2.57	12.78	0.99	18.93	1.80
0702-C	15.45	5.37	—	—	17.06	3.76	27.49	9.38	17.20	2.44	28.29	6.45	18.01	1.88	28.31	4.52
0704-D	18.58	1.50	29.24	3.58	16.96	0.93	27.94	1.88	16.74	0.79	26.66	1.11	16.73	0.71	26.53	0.96
0804-D	23.02	2.55	39.89	7.37	23.02	1.46	39.77	4.22	23.02	1.06	39.64	2.74	21.44	0.87	38.20	1.79
0904-D	32.00	5.87	48.59	13.06	32.82	3.55	48.54	7.48	32.90	2.30	48.40	4.86	32.82	1.62	48.30	3.42
0804-E	37.38	3.99	63.21	10.88	37.44	2.30	63.11	6.26	37.47	1.50	61.10	3.79	37.44	1.12	60.80	2.67
1004-F	64.51	7.08	86.90	12.26	66.20	4.32	88.08	7.32	67.53	2.98	88.38	4.81	67.67	2.13	88.65	3.42
1004-G	83.13	6.92	113.33	12.41	87.12	4.38	115.45	7.39	90.57	3.13	117.51	4.99	91.13	2.23	—	—
1003-H	114.86	10.44	—	—	122.15	6.76	—	—	126.85	4.76	—	—	131.35	3.61	—	—
1003-J	145.14	9.64	—	—	156.17	6.44	202.47	10.50	161.99	4.52	—	—	167.57	3.42	—	—
0601-B	7.76	7.17	10.84	13.83	7.79	4.08	10.89	7.87	7.80	2.63	11.26	5.44	7.94	1.93	11.62	4.06
0503-D	18.17	2.24	23.82	3.80	18.14	1.28	23.79	2.17	17.61	0.96	22.78	1.28	16.44	0.81	22.76	1.02
0604-D	14.21	0.95	21.51	1.70	13.07	0.74	20.38	1.01	13.06	0.66	18.17	0.78	13.02	0.62	18.09	0.70
0702-D	22.57	4.99	38.71	14.11	23.89	3.18	39.95	8.60	24.04	2.06	40.09	5.56	25.27	1.60	40.05	3.90
0806-E	24.61	1.48	44.45	4.29	24.56	1.02	39.89	2.06	24.07	0.84	35.06	1.11	24.01	0.74	35.01	0.97
1104-F	73.10	10.23	—	—	74.99	6.20	—	—	76.48	4.25	—	—	76.91	3.04	—	—
1104-G	94.61	10.36	—	—	98.93	6.51	—	—	102.61	4.62	—	—	104.96	3.41	—	—
0903-H	97.64	6.63	136.34	12.38	102.46	4.17	141.03	7.55	108.54	3.07	144.97	5.22	110.86	2.27	148.90	3.90
1205-H	126.75	8.18	—	—	130.13	4.96	—	—	133.00	3.41	—	—	135.80	2.53	—	—
1104-J	155.62	7.88	—	—	164.62	5.10	—	—	168.42	3.48	—	—	172.09	2.56	—	—
1204-J	171.94	11.47	—	—	178.88	7.14	—	—	—	—	—	—	—	—	—	—
0902-L	174.00	5.69	—	—	192.57	4.02	262.66	7.18	204.81	2.94	271.29	4.94	215.73	2.31	284.93	3.87
1002-L	206.36	9.39	—	—	229.97	6.77	—	—	239.97	4.74	—	—	252.33	3.70	—	—
1103-L	225.76	11.12	—	—	243.82	7.47	—	—	253.98	5.25	—	—	263.91	3.98	—	—
1203-L	250.05	13.61	—	—	265.08	8.77	—	—	—	—	—	—	—	—	—	—

LEGEND

Cap. — Capacity (Tons)
 EFT — Entering Fluid Temperature
 LFT — Leaving Fluid Temperature
 LTD — Leaving Temperature Difference
 PD — Pressure Drop (psig)
 SET — Refrigerant Saturated Evaporator Temperature

NOTES:

- Fouling factor is 0.0005.
- Shaded selections are 2-pass. All other selections are 4-pass.
- LTD = LFT - SET
- Range = EFT - LFT



BRINE RATINGS — R-507/404A (cont)
0° F SET, ETHYLENE GLYCOL SOLUTION (40%)

UNIT 10RT	6 F RANGE				8 F RANGE				10 F RANGE				12 F RANGE			
	8 F LTD		10 F LTD		8 F LTD		10 F LTD		8 F LTD		10 F LTD		8 F LTD		10 F LTD	
	Cap.	PD	Cap.	PD	Cap.	PD	Cap.	PD	Cap.	PD	Cap.	PD	Cap.	PD	Cap.	PD
0401-A	1.34	0.82	2.37	1.38	—	—	2.22	0.95	—	—	2.13	0.79	—	—	2.05	0.70
0501-A	2.46	1.90	4.11	4.34	2.46	1.18	3.68	2.21	2.46	0.97	3.66	1.54	2.45	0.84	3.57	1.14
0501-B	5.43	4.13	7.40	7.35	5.06	2.28	7.20	3.97	5.07	1.58	6.70	2.43	5.07	1.16	6.76	1.84
0401-C	4.46	0.98	8.00	1.93	4.46	0.80	7.08	1.10	4.46	0.71	7.06	0.93	4.46	0.66	7.03	0.81
0501-C	7.50	2.24	12.25	5.44	7.77	1.53	11.70	2.82	7.82	1.14	10.76	1.71	7.80	0.97	10.75	1.29
0602-C	8.41	1.84	12.35	3.47	8.56	1.20	11.33	1.81	8.41	0.96	11.30	1.27	8.38	0.85	11.26	1.05
0702-C	10.24	2.92	19.67	9.87	10.28	1.85	18.85	5.17	10.30	1.28	18.76	3.35	10.70	1.09	16.27	1.92
0704-D	12.32	1.04	17.25	1.61	12.01	0.82	16.30	1.02	11.94	0.72	15.94	0.85	11.38	0.65	15.39	0.74
0804-D	14.52	1.40	26.14	3.67	14.49	1.00	23.00	1.81	14.50	0.85	22.90	1.24	14.52	0.75	22.21	1.00
0904-D	19.12	2.67	34.61	7.71	19.83	1.76	32.84	4.00	19.86	1.20	29.42	2.29	19.87	1.02	28.61	1.58
0804-E	22.32	1.89	42.21	5.64	22.27	1.15	36.26	2.59	22.31	0.97	35.21	1.66	23.32	0.87	35.10	1.23
1004-F	47.29	4.96	67.86	9.28	44.25	2.71	66.19	5.32	45.50	1.94	64.59	3.45	45.48	1.42	60.17	2.24
1004-G	64.45	5.32	90.95	9.74	64.53	3.21	90.52	5.76	62.30	2.08	88.94	3.73	62.48	1.52	87.36	2.60
1003-H	93.51	8.62	126.56	14.78	95.95	5.36	126.78	8.67	96.16	3.60	126.99	5.76	97.89	2.73	128.71	4.28
1003-J	116.39	7.65	161.67	14.04	121.40	4.96	161.88	8.22	121.66	3.33	162.10	5.46	113.10	2.13	162.31	3.92
0601-B	5.43	4.13	7.40	7.35	5.06	2.28	7.20	3.97	5.07	1.58	6.70	2.43	5.07	1.16	6.76	1.84
0503-D	11.88	1.36	16.72	2.28	11.84	0.99	16.40	1.39	11.39	0.81	15.87	1.03	11.33	0.73	15.38	0.87
0604-D	9.11	0.78	14.12	1.08	9.03	0.68	13.10	0.81	8.52	0.61	12.52	0.70	8.47	0.58	11.96	0.64
0702-D	15.28	2.86	27.91	8.57	15.31	1.81	26.58	4.45	15.30	1.25	22.70	2.27	15.31	1.04	22.74	1.69
0806-E	17.62	1.07	25.82	1.87	17.05	0.83	24.55	1.11	16.91	0.72	23.40	0.88	16.35	0.65	22.32	0.76
1104-F	55.76	7.62	73.64	12.26	51.23	3.95	73.19	7.28	52.51	2.83	71.90	4.71	52.59	2.06	71.61	3.42
1104-G	74.38	8.01	98.71	13.33	76.15	5.04	98.80	7.87	76.05	3.41	98.88	5.26	72.17	2.27	98.96	3.80
0903-H	76.80	5.16	111.13	9.91	78.72	3.25	112.73	6.04	74.39	2.01	110.95	3.90	76.37	1.54	110.71	2.82
1205-H	97.17	6.11	—	—	97.22	3.69	—	—	93.90	2.39	—	—	94.25	1.74	119.30	2.54
1104-J	123.73	6.26	164.61	10.44	126.59	3.91	164.69	6.15	126.41	2.64	164.77	4.10	120.10	1.77	164.88	2.96
1204-J	137.63	9.10	—	—	138.27	5.42	—	—	140.75	3.80	—	—	141.13	2.76	—	—
0902-L	147.00	5.00	—	—	154.70	3.25	216.84	5.90	162.07	2.38	220.33	4.04	162.61	1.72	223.88	2.98
1002-L	178.85	8.68	—	—	187.90	5.56	244.35	8.84	192.48	3.86	249.03	6.02	196.78	2.89	256.28	4.58
1103-L	188.05	9.44	—	—	196.90	6.09	—	—	201.33	4.25	—	—	205.74	3.19	—	—
1203-L	208.80	11.53	—	—	214.45	7.09	—	—	219.89	4.93	—	—	225.20	3.70	—	—

-20 F SET, ETHYLENE GLYCOL SOLUTION (50%)

UNIT 10RT	6 F RANGE				8 F RANGE				10 F RANGE				12 F RANGE			
	8 F LTD		10 F LTD		8 F LTD		10 F LTD		8 F LTD		10 F LTD		8 F LTD		10 F LTD	
	Cap.	PD	Cap.	PD	Cap.	PD	Cap.	PD	Cap.	PD	Cap.	PD	Cap.	PD	Cap.	PD
0401-A	—	—	—	—	—	—	—	—	—	—	—	—	—	—	—	—
0501-A	1.22	1.04	2.05	2.15	—	—	1.84	1.10	—	—	1.73	0.90	1.22	0.70	1.64	0.78
0501-B	2.72	1.99	4.08	3.91	2.53	1.11	3.87	2.18	2.44	0.90	3.59	1.29	2.44	0.81	3.40	0.99
0401-C	—	—	3.99	1.16	—	—	3.53	0.84	—	—	3.31	0.72	—	—	3.40	0.68
0501-C	4.19	1.60	6.56	3.16	3.91	1.01	6.02	1.71	3.88	0.86	5.84	1.15	3.89	0.78	5.54	0.95
0602-C	4.57	1.17	6.89	2.21	4.37	0.90	6.39	1.23	4.38	0.79	6.16	0.97	4.39	0.73	5.83	0.81
0702-C	5.98	2.09	9.45	4.15	5.79	1.23	9.00	2.41	5.58	0.96	8.58	1.56	5.55	0.86	8.54	1.16
0704-D	6.63	0.83	9.62	1.07	6.65	0.72	8.96	0.81	6.68	0.66	8.67	0.72	6.68	0.62	8.65	0.67
0804-D	8.04	0.99	13.04	1.79	8.02	0.82	12.20	1.09	8.03	0.73	11.44	0.86	8.05	0.68	11.10	0.76
0904-D	11.94	1.56	17.32	3.45	11.51	1.02	16.38	1.98	9.05	0.84	15.53	1.26	10.37	0.81	14.70	0.99
0804-E	12.61	1.16	21.03	2.61	12.31	0.91	18.82	1.35	12.33	0.80	18.14	1.01	12.55	0.74	17.54	0.86
1004-F	27.86	3.60	39.61	5.77	26.57	2.24	38.15	3.51	26.46	1.66	36.70	2.39	25.74	1.27	35.33	1.75
1004-G	37.98	3.59	54.02	5.94	37.85	2.35	52.94	3.65	37.81	1.71	51.18	2.46	36.91	1.29	50.19	1.82
1003-H	56.12	5.54	77.34	9.03	56.17	3.52	75.30	5.29	56.18	2.50	74.85	3.68	56.01	1.91	74.59	2.75
1003-J	69.77	4.92	98.19	8.39	69.80	3.14	95.68	4.93	69.86	2.24	93.22	3.28	69.63	1.71	92.85	2.45
0601-B	2.72	1.99	4.08	3.91	2.53	1.11	3.87	2.18	2.44	0.90	3.59	1.29	2.44	0.81	3.40	0.99
0503-D	6.21	0.96	9.38	1.48	5.97	0.79	8.78	0.99	6.21	0.72	8.22	0.80	6.22	0.67	8.18	0.74
0604-D	5.09	0.70	7.36	0.81	5.09	0.63	7.06	0.70	5.11	0.60	6.94	0.64	5.12	0.58	6.82	0.61
0702-D	8.67	1.94	13.35	3.72	8.35	1.13	12.64	2.15	8.03	0.93	11.99	1.38	8.16	0.85	11.37	1.04
0806-E	10.20	0.84	13.49	1.00	10.22	0.72	13.21	0.81	10.26	0.66	13.14	0.72	10.26	0.62	12.93	0.66
1104-F	32.02	4.95	43.96	7.69	31.87	3.26	42.87	4.76	31.16	2.31	41.48	3.22	30.39	1.75	40.68	2.40
1104-G	44.39	5.31	59.92	8.22	44.37	3.43	58.75	5.01	44.24	2.47	57.76	3.43	43.37	1.85	57.54	2.59
0903-H	46.70	3.58	67.81	6.27	46.62	2.31	65.90	3.71	46.61	1.67	63.98	2.48	44.86	1.21	63.58	1.87
1205-H	58.19	4.30	77.54	6.37	58.08	2.82	75.96	3.95	56.87	2.00	74.63	2.75	56.63	1.56	73.44	2.05
1104-J	73.22	4.05	99.96	6.41	73.21	2.62	98.11	3.92	73.09	1.89	95.59	2.63	72.85	1.45	95.23	1.99
1204-J	82.69	5.88	106.67	8.57	82.82	3.76	105.31	5.21	82.61	2.69	105.07	3.65	82.56	2.05	105.02	2.74
0902-L	93.06	3.46	134.86	6.29	96.43	2.33	134.99	3.84	96.95	1.64	131.99	2.53	97.00	1.24	131.78	1.88
1002-L	111.59	5.59	153.44	9.37	115.51	3.69	153.41	5.74	116.01	2.58	153.51	3.92	117.70	1.99	153.77	2.89
1103-L	117.67	6.30	155.53	9.69	121.75	4.21	155.30	5.94	121.89	2.96	155.39	4.11	122.14	2.24	157.08	3.13
1203-L	130.59	7.45	165.42	10.93	132.93	4.79	166.14	6.65	135.03	3.45	168.25	4.69	137.28	2.67	169.21	3.48

LEGEND

Cap. — Capacity (Tons) LTD — Leaving Temperature Difference
 EFT — Entering Fluid Temperature PD — Pressure Drop (psig)
 LFT — Leaving Fluid Temperature SET — Refrigerant Saturated Evaporator Temperature

NOTES:

- Fouling factor is 0.0005.
- Shaded selections are 2-pass. All other selections are 4-pass.
- LTD = LFT - SET
- Range = EFT - LFT

Performance data (cont)



BRINE RATINGS — R-22 20 F SET, PROPYLENE GLYCOL SOLUTION (20%)

UNIT 10RT	6 F RANGE				8 F RANGE				10 F RANGE				12 F RANGE			
	8 F LTD		10 F LTD		8 F LTD		10 F LTD		8 F LTD		10 F LTD		8 F LTD		10 F LTD	
	Cap.	PD	Cap.	PD	Cap.	PD	Cap.	PD	Cap.	PD	Cap.	PD	Cap.	PD	Cap.	PD
0401-A	2.02	0.87	4.04	2.45	—	—	4.02	1.40	2.01	0.66	3.80	0.97	2.03	0.62	3.79	0.83
0501-A	4.24	3.46	6.71	8.40	4.27	1.97	6.85	5.01	4.42	1.37	6.85	3.24	4.42	1.06	6.85	2.27
0501-B	8.98	8.11	9.91	9.82	9.30	4.93	10.53	6.29	9.34	3.18	10.61	4.06	9.61	2.37	11.21	3.17
0401-C	6.75	1.09	12.43	3.26	6.79	0.84	12.76	1.98	7.15	0.74	12.78	1.28	6.43	0.65	12.77	1.02
0501-C	12.50	4.12	19.14	9.52	13.40	2.72	19.26	5.44	13.89	1.89	19.69	3.69	14.32	1.41	20.12	2.71
0602-C	14.62	3.53	20.43	6.78	15.18	2.17	17.46	2.87	15.65	1.51	18.57	2.10	15.70	1.12	18.67	1.47
0702-C	17.80	6.01	—	—	18.43	3.69	27.46	7.93	18.84	2.48	28.84	5.64	19.24	1.80	30.12	4.33
0704-D	22.29	1.81	27.73	2.72	21.88	1.08	29.94	1.80	21.36	0.86	29.84	1.17	19.72	0.73	29.76	0.98
0804-D	25.73	2.69	41.56	6.83	25.78	1.55	41.63	3.91	25.82	1.09	41.68	2.54	25.85	0.91	41.64	1.79
0904-D	31.82	4.93	52.76	12.99	33.24	3.07	55.17	8.22	34.61	2.16	55.28	5.34	35.87	1.64	55.34	3.75
0804-E	40.15	3.90	63.84	9.39	40.32	2.25	64.00	5.40	41.04	1.53	67.26	3.92	41.16	1.13	67.24	2.77
1004-F	70.38	6.98	98.92	13.21	73.03	4.30	101.50	7.94	75.50	3.00	103.69	5.41	77.66	2.26	105.90	3.99
1004-G	87.83	6.41	124.55	12.39	93.93	4.21	130.61	7.79	99.79	3.10	133.93	5.30	102.94	2.33	139.33	4.07
1003-H	120.38	9.53	—	—	131.40	6.51	180.19	11.88	141.93	4.97	187.65	8.34	149.15	3.87	195.02	6.33
1003-J	153.20	8.98	—	—	166.87	6.10	230.94	11.42	176.58	4.41	240.20	7.99	185.51	3.43	249.36	6.04
0601-B	8.98	8.11	9.91	9.82	9.30	4.93	10.53	6.29	9.34	3.18	10.61	4.06	9.61	2.37	11.21	3.17
0503-D	20.82	2.49	29.98	5.02	20.89	1.42	29.94	2.87	20.89	1.04	29.91	1.85	20.86	0.88	29.89	1.30
0604-D	16.28	0.99	25.48	1.98	14.07	0.72	24.56	1.12	14.48	0.66	23.62	0.87	14.48	0.62	22.70	0.74
0702-D	26.69	5.79	38.28	11.77	27.59	3.57	40.37	7.46	27.81	2.31	40.64	4.83	28.71	1.74	42.60	3.74
0806-E	31.87	1.99	44.94	3.76	28.98	1.09	42.97	2.04	28.96	0.90	41.35	1.25	28.94	0.79	38.42	0.97
1104-F	81.66	10.50	—	—	86.59	6.80	114.49	11.54	89.25	4.71	117.22	7.84	91.78	3.52	119.90	5.76
1104-G	102.59	10.03	141.74	18.76	111.79	6.89	147.97	11.72	115.72	4.76	152.03	7.95	121.72	3.74	158.08	6.08
0903-H	98.82	5.64	146.20	11.97	108.61	3.93	155.98	7.81	115.59	2.89	162.78	5.51	122.05	2.28	166.78	4.04
1205-H	141.71	8.39	—	—	150.52	5.44	195.61	8.83	155.28	3.77	203.28	6.27	159.90	2.82	208.25	4.61
1104-J	171.84	8.07	233.73	14.40	182.70	5.18	243.78	8.94	192.60	3.75	253.40	6.29	198.42	2.79	262.96	4.77
1204-J	193.00	11.96	—	—	208.52	8.05	265.05	12.56	215.56	5.51	—	—	226.00	4.28	—	—
0902-L	172.88	4.74	—	—	191.65	3.31	272.90	6.46	210.06	2.58	295.75	4.95	222.79	2.03	308.71	3.77
1002-L	212.45	8.41	—	—	233.80	5.76	—	—	259.39	4.64	342.96	7.83	273.72	3.61	362.47	6.15
1103-L	240.22	10.58	—	—	263.08	7.21	352.65	12.68	284.46	5.50	368.66	8.91	299.74	4.27	389.17	7.02
1203-L	276.53	14.01	—	—	301.33	9.44	—	—	318.60	6.79	—	—	335.56	5.26	—	—

10 F SET, PROPYLENE GLYCOL SOLUTION (30%)

UNIT 10RT	6 F RANGE				8 F RANGE				10 F RANGE				12 F RANGE			
	8 F LTD		10 F LTD		8 F LTD		10 F LTD		8 F LTD		10 F LTD		8 F LTD		10 F LTD	
	Cap.	PD	Cap.	PD	Cap.	PD	Cap.	PD	Cap.	PD	Cap.	PD	Cap.	PD	Cap.	PD
0401-A	—	—	2.14	1.09	—	—	2.01	0.83	—	—	—	—	—	—	—	—
0501-A	2.29	1.46	4.24	3.88	2.28	1.02	3.61	1.81	2.28	0.85	3.61	1.27	2.21	0.74	3.59	1.04
0501-B	5.58	3.67	8.70	8.37	5.26	2.08	8.37	4.44	5.28	1.45	7.45	2.45	5.27	1.11	7.44	1.81
0401-C	—	—	6.59	1.23	—	—	6.42	0.95	—	—	6.40	0.81	—	—	6.38	0.73
0501-C	7.17	1.81	12.96	4.98	7.21	1.17	12.47	2.65	7.43	1.00	11.06	1.51	7.44	0.87	11.05	1.14
0602-C	8.72	1.68	14.28	3.79	8.72	1.11	12.79	1.88	8.72	0.92	12.54	1.27	8.70	0.81	12.27	1.03
0702-C	12.30	3.31	16.81	5.98	11.64	1.91	16.47	3.28	11.65	1.33	15.43	2.02	11.66	1.07	15.47	1.50
0704-D	12.80	0.99	19.19	1.62	12.29	0.78	18.21	1.03	12.25	0.69	17.64	0.84	11.76	0.63	17.11	0.74
0804-D	16.47	1.47	22.36	2.38	15.98	0.99	21.99	1.42	15.91	0.84	21.47	1.04	15.86	0.75	21.38	0.90
0904-D	18.77	2.18	33.24	5.90	18.74	1.34	27.82	2.55	18.71	1.03	27.78	1.74	18.71	0.90	27.72	1.27
0804-E	25.32	1.96	37.37	3.74	25.27	1.21	33.83	1.93	25.18	0.99	33.65	1.32	24.44	0.84	33.55	1.06
1004-F	47.24	4.17	73.11	8.87	44.68	2.33	70.80	4.99	44.84	1.58	70.28	3.36	44.92	1.16	63.55	2.05
1004-G	63.66	4.37	96.93	9.12	60.32	2.44	96.79	5.40	60.81	1.67	96.53	3.62	63.39	1.32	85.21	2.09
1003-H	93.58	7.20	138.29	14.57	97.03	4.60	138.91	8.54	97.50	3.10	141.70	5.95	90.37	1.98	141.85	4.27
1003-J	116.21	6.39	172.16	12.93	120.42	4.08	176.12	7.95	120.92	2.75	176.22	5.28	115.59	1.87	176.27	3.79
0601-B	5.58	3.67	8.70	8.37	5.26	2.08	8.37	4.44	5.28	1.45	7.45	2.45	5.27	1.11	7.44	1.81
0503-D	11.76	1.13	18.11	2.20	11.35	0.89	17.67	1.33	11.33	0.77	17.20	1.01	10.93	0.68	16.40	0.84
0604-D	8.64	0.72	14.51	1.01	—	—	13.59	0.78	—	—	12.74	0.67	—	—	12.27	0.62
0702-D	16.57	2.75	25.10	5.71	17.03	1.82	24.48	3.14	17.02	1.26	22.89	1.97	17.01	1.04	22.91	1.47
0806-E	18.78	1.04	28.07	1.84	17.87	0.80	26.34	1.08	17.75	0.70	25.33	0.87	16.90	0.64	24.40	0.75
1104-F	58.68	6.97	84.51	13.13	58.51	4.21	84.06	7.77	54.87	2.55	81.76	4.93	55.90	1.93	81.37	3.58
1104-G	78.83	7.52	112.14	13.96	79.10	4.51	112.21	8.22	79.26	3.05	112.08	5.48	75.80	2.08	112.02	3.95
0903-H	74.57	4.15	115.36	8.96	68.20	2.14	115.46	5.29	71.50	1.58	115.54	3.53	74.66	1.25	115.31	2.55
1205-H	104.10	5.81	149.97	11.10	97.33	3.14	146.50	6.23	99.64	2.21	145.94	4.18	101.55	1.67	133.29	2.57
1104-J	127.16	5.48	183.58	10.48	131.44	3.51	187.23	6.48	121.74	2.07	183.45	4.11	122.41	1.52	183.28	2.96
1204-J	148.97	8.73	204.79	15.39	153.96	5.54	208.57	9.47	154.36	3.72	209.13	6.28	143.56	2.38	209.67	4.51
0902-L	136.22	3.64	210.38	7.95	142.64	2.35	216.81	4.91	148.86	1.71	223.04	3.43	142.83	1.16	228.51	2.58
1002-L	171.79	6.61	—	—	184.73	4.49	266.43	8.69	192.14	3.20	273.13	6.00	198.62	2.46	274.85	4.29
1103-L	194.68	8.45	—	—	202.74	5.36	284.68	9.84	210.23	3.82	286.40	6.51	211.29	2.76	293.21	4.88
1203-L	221.63	10.57	—	—	236.74	7.09	311.72	11.50	244.70	5.01	319.77	7.96	252.45	3.82	327.81	5.95

LEGEND

Cap. — Capacity (Tons)
 EFT — Entering Fluid Temperature
 LFT — Leaving Fluid Temperature
 LTD — Leaving Temperature Difference
 PD — Pressure Drop (psig)
 SET — Refrigerant Saturated Evaporator Temperature

NOTES:

- Fouling factor is 0.0005.
- Shaded selections are 2-pass. All other selections are 4-pass.
- LTD = LFT - SET
- Range = EFT - LFT



BRINE RATINGS — R-22 (cont)
0° F SET, PROPYLENE GLYCOL SOLUTION (40%)

UNIT 10RT	6 F RANGE				8 F RANGE				10 F RANGE				12 F RANGE			
	8 F LTD		10 F LTD		8 F LTD		10 F LTD		8 F LTD		10 F LTD		8 F LTD		10 F LTD	
	Cap.	PD	Cap.	PD	Cap.	PD	Cap.	PD	Cap.	PD	Cap.	PD	Cap.	PD	Cap.	PD
0401-A	—	—	—	—	—	—	—	—	—	—	—	—	—	—	—	—
0501-A	—	—	2.05	1.74	—	—	—	—	—	—	—	—	—	—	—	—
0501-B	—	—	4.81	4.19	—	—	4.35	2.13	—	—	4.04	1.27	—	—	3.73	0.96
0401-C	—	—	—	—	—	—	—	—	—	—	—	—	—	—	—	—
0501-C	—	—	6.95	2.80	—	—	6.25	1.48	—	—	5.99	1.07	—	—	5.74	0.89
0602-C	—	—	7.89	2.21	—	—	7.28	1.23	—	—	6.96	0.97	—	—	6.41	0.80
0702-C	6.88	2.11	10.62	4.09	6.53	1.22	9.97	2.30	6.49	0.99	9.59	1.51	6.17	0.84	9.23	1.12
0704-D	—	—	11.20	1.09	—	—	10.10	0.81	—	—	9.62	0.71	—	—	9.60	0.66
0804-D	9.23	0.99	14.63	1.77	8.91	0.80	13.45	1.06	9.16	0.73	12.55	0.84	9.17	0.68	12.20	0.75
0904-D	11.79	1.56	16.94	2.72	11.11	1.01	15.93	1.54	11.06	0.86	15.23	1.07	11.08	0.78	14.58	0.89
0804-E	14.98	1.26	22.55	2.36	14.03	0.91	21.45	1.37	14.07	0.80	19.74	0.97	14.10	0.73	18.78	0.82
1004-F	26.43	2.78	43.59	5.43	25.80	1.83	41.21	3.21	24.83	1.30	39.94	2.21	24.69	1.03	37.82	1.57
1004-G	39.29	3.14	60.37	5.81	35.00	1.76	7.51	3.38	34.83	1.29	56.01	2.30	34.75	1.01	54.54	1.68
1003-H	58.03	4.76	86.47	8.75	56.47	2.90	85.94	5.37	56.47	2.07	82.83	3.47	56.45	1.58	82.49	2.59
1003-J	71.98	4.24	109.05	8.02	71.86	2.71	106.63	4.76	71.86	1.94	106.28	3.30	71.85	1.48	102.35	2.30
0601-B	—	—	4.81	4.19	—	—	4.35	2.13	—	—	4.04	1.27	—	—	3.73	0.96
0503-D	—	—	10.44	1.43	—	—	9.50	0.95	—	—	8.63	0.77	—	—	8.62	0.71
0604-D	—	—	—	—	—	—	—	—	—	—	—	—	—	—	—	—
0702-D	10.09	2.03	15.45	3.84	9.33	1.10	14.41	2.15	9.04	0.93	13.82	1.41	9.04	0.83	2.85	1.03
0806-E	—	—	15.99	1.03	—	—	15.41	0.82	—	—	15.02	0.72	—	—	14.98	0.67
1104-F	35.59	4.82	52.33	8.26	34.35	3.01	50.78	5.02	33.21	2.10	48.51	3.30	33.08	1.63	47.17	2.42
1104-G	47.90	4.89	72.23	9.13	47.73	3.16	69.28	5.26	46.38	2.17	68.94	3.67	46.29	1.67	66.11	2.57
0903-H	46.75	2.95	71.25	5.50	45.98	1.87	68.08	3.17	45.17	1.32	67.76	2.23	44.45	1.00	64.86	1.56
1205-H	64.34	4.10	95.15	7.17	62.30	2.56	92.68	4.35	62.13	1.87	88.84	2.87	61.94	1.45	88.26	2.18
1104-J	78.78	3.73	116.93	6.69	78.55	2.41	114.20	4.02	76.51	1.66	111.84	2.72	76.41	1.28	111.25	2.04
1204-J	93.85	5.84	135.11	10.22	93.72	3.72	132.47	6.08	93.76	2.64	131.82	4.22	93.61	2.01	129.39	3.04
0902-L	95.50	2.97	136.67	5.12	95.58	1.89	136.48	3.14	95.71	1.34	136.55	2.17	95.94	1.02	136.57	1.61
1002-L	116.04	4.89	170.99	9.01	116.65	3.05	171.30	5.52	119.93	2.23	171.65	3.76	123.02	1.74	171.59	2.77
1103-L	127.48	5.87	187.09	10.82	127.98	3.69	187.04	6.58	131.43	2.71	187.05	4.52	134.58	2.13	186.93	3.34
1203-L	150.89	7.71	212.13	13.28	154.76	4.99	212.69	8.10	155.65	3.48	212.60	5.52	155.96	2.60	212.82	4.05

-20 F SET, PROPYLENE GLYCOL SOLUTION (50%)

UNIT 10RT	6 F RANGE				8 F RANGE				10 F RANGE				12 F RANGE			
	8 F LTD		10 F LTD		8 F LTD		10 F LTD		8 F LTD		10 F LTD		8 F LTD		10 F LTD	
	Cap.	PD	Cap.	PD	Cap.	PD	Cap.	PD	Cap.	PD	Cap.	PD	Cap.	PD	Cap.	PD
0401-A	—	—	—	—	—	—	—	—	—	—	—	—	—	—	—	—
0501-A	—	—	—	—	—	—	—	—	—	—	—	—	—	—	—	—
0501-B	—	—	—	—	—	—	—	—	—	—	—	—	—	—	—	—
0401-C	—	—	—	—	—	—	—	—	—	—	—	—	—	—	—	—
0501-C	—	—	—	—	—	—	—	—	—	—	—	—	—	—	—	—
0602-C	—	—	—	—	—	—	—	—	—	—	—	—	—	—	—	—
0702-C	—	—	5.80	3.59	—	—	5.51	2.25	—	—	5.48	1.66	—	—	5.33	1.24
0704-D	—	—	—	—	—	—	—	—	—	—	—	—	—	—	—	—
0804-D	—	—	8.56	1.85	—	—	8.26	1.20	—	—	8.00	0.99	—	—	7.95	0.88
0904-D	—	—	10.03	2.77	—	—	9.72	1.80	—	—	9.65	1.33	—	—	9.38	1.07
0804-E	—	—	13.17	2.36	—	—	12.88	1.57	—	—	12.65	1.13	—	—	12.59	1.01
1004-F	16.54	7.17	21.15	7.34	16.55	5.93	20.68	5.69	16.53	5.16	20.62	4.79	16.54	4.61	20.61	4.17
1004-G	22.62	6.28	28.36	6.50	22.65	5.07	28.03	4.98	22.67	4.34	28.00	4.12	22.73	3.83	28.03	3.54
1003-H	31.79	7.18	48.60	9.38	31.85	5.61	39.35	5.74	31.91	4.68	39.38	4.64	32.31	4.07	39.48	3.91
1003-J	39.48	6.49	49.22	6.99	39.58	5.07	48.85	5.19	40.01	4.26	48.91	4.19	40.52	3.69	49.67	3.58
0601-B	—	—	—	—	—	—	—	—	—	—	—	—	—	—	—	—
0503-D	—	—	—	—	—	—	—	—	—	—	—	—	—	—	—	—
0604-D	—	—	—	—	—	—	—	—	—	—	—	—	—	—	—	—
0702-D	—	—	8.49	3.47	—	—	8.03	2.17	—	—	7.99	1.60	—	—	—	—
0806-E	—	—	—	—	—	—	—	—	—	—	—	—	—	—	—	—
1104-F	18.20	8.66	29.35	10.85	18.20	7.05	28.68	8.05	18.41	6.10	28.14	6.45	18.48	5.40	28.07	5.47
1104-G	24.40	7.70	39.70	10.15	24.64	6.20	39.46	7.50	24.74	5.26	39.40	5.99	25.11	4.62	38.74	4.94
0903-H	28.17	5.63	36.64	6.15	28.20	4.48	35.88	4.57	28.21	3.79	35.76	3.73	28.51	3.33	35.74	3.17
1205-H	32.60	7.33	55.11	9.60	32.69	5.97	53.25	6.97	33.14	5.17	53.15	5.65	33.35	4.57	53.02	4.77
1104-J	40.67	5.86	66.04	7.82	40.75	4.65	65.70	5.75	41.28	3.95	64.72	4.51	41.88	3.46	63.75	3.71
1204-J	42.81	7.30	77.30	10.99	43.42	5.81	74.58	7.68	44.13	4.90	74.54	6.05	44.89	4.26	74.39	4.99
0902-L	58.50	4.64	74.26	5.21	58.86	3.53	74.04	3.80	59.00	2.89	74.11	3.01	60.20	2.49	74.31	2.49
1002-L	64.84	6.13	103.14	8.94	65.17	4.60	96.32	5.84	66.51	3.78	98.97	4.66	67.01	3.19	99.10	3.78
1103-L	65.95	7.27	112.62	11.17	67.28	5.67	105.54	7.38	67.88	4.63	108.35	5.91	69.48	3.99	108.38	4.81
1203-L	69.31	7.61	131.04	13.27	70.63	5.84	126.29	8.91	93.89	5.79	122.64	6.59	94.30	4.79	122.70	5.32

LEGEND

Cap. — Capacity (Tons) LTD — Leaving Temperature Difference
 EFT — Entering Fluid Temperature PD — Pressure Drop (psig)
 LFT — Leaving Fluid Temperature SET — Refrigerant Saturated Evaporator Temperature

NOTES:

- Fouling factor is 0.0005.
- Shaded selections are 2-pass. All other selections are 4-pass.
- LTD = LFT - SET
- Range = EFT - LFT

Performance data (cont)



BRINE RATINGS — R-134a 20 F SET, PROPYLENE GLYCOL SOLUTION (20%)

UNIT 10RT	6 F RANGE				8 F RANGE				10 F RANGE				12 F RANGE			
	8 F LTD		10 F LTD		8 F LTD		10 F LTD		8 F LTD		10 F LTD		8 F LTD		10 F LTD	
	Cap.	PD	Cap.	PD	Cap.	PD	Cap.	PD	Cap.	PD	Cap.	PD	Cap.	PD	Cap.	PD
0401-A	1.89	0.83	3.41	1.76	—	—	3.40	1.09	1.89	0.64	3.29	0.85	1.96	0.61	3.28	0.75
0501-A	3.43	2.28	5.00	4.71	3.59	1.43	5.07	2.77	3.60	1.04	5.08	1.79	3.61	0.88	5.09	1.26
0501-B	6.55	4.31	8.67	7.56	6.82	2.68	9.28	4.92	6.98	1.81	9.36	3.18	7.14	1.32	9.94	2.52
0401-C	6.00	0.97	10.16	2.21	6.04	0.77	10.19	1.26	5.67	0.67	10.50	1.01	6.03	0.64	10.50	0.86
0501-C	10.02	2.72	13.69	4.92	10.52	1.70	13.98	2.91	10.60	1.10	14.40	2.01	11.02	0.99	14.82	1.50
0602-C	11.04	2.07	14.57	3.52	11.32	1.24	15.18	2.17	11.40	0.97	16.28	1.62	11.66	0.85	16.35	1.14
0702-C	12.33	2.94	21.91	9.00	13.70	2.06	23.26	5.78	15.04	1.61	24.00	3.96	15.74	1.23	24.68	2.93
0704-D	16.06	1.05	24.51	2.15	16.04	0.82	24.50	1.23	15.49	0.71	24.49	0.97	15.94	0.66	23.54	0.80
0804-D	19.59	1.59	34.20	4.69	20.75	1.10	34.32	2.69	20.86	0.89	34.35	1.75	19.60	0.76	34.34	1.23
0904-D	26.39	3.41	41.42	8.23	27.76	2.16	41.62	4.72	29.07	1.54	42.76	3.26	29.16	1.13	42.92	2.30
0804-E	30.09	2.21	52.57	6.46	31.91	1.43	54.28	3.98	33.69	1.11	54.38	2.59	33.78	0.93	54.41	1.83
1004-F	60.93	5.32	79.66	8.81	63.34	3.33	81.25	5.23	64.68	2.27	82.74	3.52	65.98	1.68	84.88	2.64
1004-G	77.32	5.02	102.70	8.64	81.89	3.25	106.01	5.26	84.95	2.29	109.24	3.63	87.96	1.74	112.40	2.71
1003-H	106.65	7.63	138.58	12.55	112.86	4.86	145.44	7.96	119.61	3.59	150.24	5.44	123.92	2.70	156.93	4.21
1003-J	134.64	7.01	176.30	11.74	143.88	4.59	184.83	7.43	150.80	3.28	190.75	5.07	157.61	2.53	199.08	3.91
0601-B	6.55	4.31	8.67	7.56	6.82	2.68	9.28	4.92	6.98	1.81	9.36	3.18	7.14	1.32	9.94	2.52
0503-D	15.84	1.46	21.22	2.59	15.92	0.99	21.32	1.48	16.26	0.83	21.67	1.08	15.36	0.72	21.75	0.91
0604-D	12.75	0.80	18.95	1.14	12.24	0.68	18.21	0.85	12.28	0.62	18.08	0.73	12.63	0.59	17.17	0.65
0702-D	18.61	2.89	31.94	8.25	19.21	1.74	33.96	5.34	21.24	1.38	34.21	3.45	21.40	1.07	35.20	2.57
0806-E	22.43	1.12	39.30	2.94	22.49	0.87	37.45	1.58	22.56	0.75	33.57	1.01	22.94	0.69	33.59	0.87
1104-F	66.67	7.07	84.15	11.08	69.19	4.41	86.83	6.76	71.63	3.11	89.43	4.68	74.04	2.37	91.98	3.50
1104-G	86.05	7.17	108.99	11.25	90.77	4.62	113.69	7.05	95.30	3.35	118.30	4.99	98.80	2.54	122.05	3.72
0903-H	91.86	4.92	126.01	8.96	98.68	3.27	132.18	5.69	102.53	2.29	136.12	3.90	108.56	1.83	139.98	2.89
1205-H	115.11	5.66	143.54	8.60	119.71	3.53	148.52	5.26	124.17	2.49	154.27	3.74	128.55	1.90	158.98	2.80
1104-J	142.65	5.56	182.34	8.96	151.74	3.67	188.71	5.43	157.44	2.56	197.29	3.92	162.97	1.93	203.30	2.90
1204-J	154.32	7.80	190.07	11.59	162.52	4.97	198.59	7.22	170.51	3.58	206.86	5.09	176.90	2.69	—	—
0902-L	161.40	4.11	—	—	179.24	2.92	240.66	5.12	191.69	2.17	252.88	3.66	203.55	1.72	264.96	2.82
1002-L	191.52	6.91	—	—	208.66	4.68	266.72	7.47	219.96	3.35	280.46	5.34	233.25	2.65	294.01	4.12
1103-L	206.39	7.90	262.90	12.53	221.34	5.20	277.38	7.99	233.24	3.74	291.60	5.75	247.12	2.97	303.79	4.35
1203-L	223.90	9.30	274.87	13.56	237.49	5.92	290.53	8.68	252.71	4.38	305.85	6.27	265.60	3.39	—	—

10 F SET, PROPYLENE GLYCOL SOLUTION (30%)

UNIT 10RT	6 F RANGE				8 F RANGE				10 F RANGE				12 F RANGE			
	8 F LTD		10 F LTD		8 F LTD		10 F LTD		8 F LTD		10 F LTD		8 F LTD		10 F LTD	
	Cap.	PD	Cap.	PD	Cap.	PD	Cap.	PD	Cap.	PD	Cap.	PD	Cap.	PD	Cap.	PD
0401-A	—	—	2.01	1.03	—	—	1.89	0.79	—	—	—	—	—	—	—	—
0501-A	2.05	1.20	3.12	2.29	2.05	0.93	3.12	1.44	2.05	0.79	3.11	1.08	2.04	0.71	3.09	0.92
0501-B	4.21	2.30	6.08	4.13	4.35	1.53	5.76	2.33	4.35	1.11	5.77	1.61	4.35	0.94	5.89	1.25
0401-C	—	—	6.03	1.13	—	—	6.02	0.90	—	—	6.00	0.78	—	—	5.83	0.70
0501-C	6.23	1.46	9.82	2.92	6.46	1.08	9.11	1.61	6.49	0.90	9.13	1.14	6.68	0.82	9.15	1.00
0602-C	7.13	1.22	9.76	1.95	7.26	0.96	9.76	1.23	7.26	0.82	9.65	0.98	7.27	0.73	9.65	0.86
0702-C	8.58	1.88	15.01	4.85	8.73	1.21	13.04	2.22	8.88	1.00	13.66	1.68	8.94	0.87	13.69	1.24
0704-D	10.61	0.86	14.37	1.08	10.40	0.72	14.10	0.85	10.16	0.64	13.85	0.73	10.13	0.61	13.81	0.67
0804-D	12.27	1.02	19.62	1.92	12.26	0.82	19.55	1.17	12.26	0.72	19.52	0.97	12.28	0.66	18.98	0.83
0904-D	15.91	1.67	27.60	4.15	15.96	1.10	24.96	2.14	16.59	0.94	24.92	1.46	16.62	0.83	24.87	1.12
0804-E	19.14	1.25	30.11	2.59	19.15	0.95	30.03	1.57	19.18	0.81	30.00	1.13	19.23	0.73	29.95	0.96
1004-F	40.15	3.17	59.89	6.26	41.20	2.02	58.67	3.64	41.34	1.38	55.23	2.23	42.25	1.07	55.29	1.62
1004-G	57.50	3.68	79.07	6.27	54.79	2.05	78.85	3.75	57.29	1.53	78.71	2.53	57.57	1.11	75.56	1.73
1003-H	82.35	5.73	110.44	9.60	84.34	3.58	112.02	5.85	80.61	2.25	112.52	3.91	82.60	1.71	112.96	2.83
1003-J	102.57	5.09	139.60	8.78	106.62	3.30	141.42	5.34	101.88	2.07	143.33	3.68	104.32	1.57	143.84	2.65
0601-B	4.21	2.30	6.08	4.13	4.35	1.53	5.76	2.33	4.35	1.11	5.77	1.61	4.35	0.94	5.89	1.25
0503-D	9.96	1.00	14.12	1.47	9.96	0.81	14.01	1.03	9.95	0.72	13.64	0.85	9.93	0.66	13.60	0.76
0604-D	7.93	0.69	12.01	0.87	7.70	0.61	11.39	0.71	7.67	0.58	10.94	0.64	—	—	10.85	0.60
0702-D	12.82	1.84	21.21	4.17	13.02	1.18	19.11	2.14	13.07	0.98	19.19	1.49	13.29	0.87	19.20	1.10
0806-E	15.44	0.89	20.71	1.13	15.03	0.72	20.18	0.87	14.93	0.65	19.73	0.74	14.52	0.61	19.63	0.68
1104-F	48.67	5.01	64.43	8.10	47.21	2.92	63.92	4.77	47.37	1.98	61.11	3.02	48.43	1.52	61.43	2.20
1104-G	65.84	5.46	85.70	8.57	66.12	3.30	86.02	5.10	64.43	2.16	87.23	3.55	66.00	1.64	87.52	2.58
0903-H	68.36	3.52	98.85	6.70	66.33	2.05	98.88	3.98	68.27	1.46	98.80	2.68	69.88	1.11	98.78	1.94
1205-H	86.14	4.20	110.81	6.38	83.88	2.45	110.90	3.83	84.42	1.66	106.74	2.42	86.41	1.27	108.75	1.83
1104-J	109.03	4.20	142.57	6.62	111.19	2.64	144.36	4.06	106.69	1.66	144.81	2.73	109.16	1.26	146.77	2.04
1204-J	118.98	5.81	150.81	8.92	121.27	3.64	153.60	5.46	118.24	2.38	154.96	3.66	121.27	1.81	157.53	2.73
0902-L	130.17	3.35	185.76	6.31	136.40	2.18	191.37	3.94	142.19	1.59	192.52	2.63	136.65	1.07	197.84	2.00
1002-L	156.84	5.68	208.42	9.43	164.11	3.64	212.94	5.70	170.31	2.63	219.29	4.01	171.81	1.90	225.65	3.04
1103-L	165.15	6.25	213.98	9.89	172.13	4.03	218.63	6.01	176.16	2.82	225.13	4.26	180.04	2.13	231.68	3.25
1203-L	179.80	7.28	224.48	10.82	187.21	4.68	232.26	6.79	192.23	3.26	238.11	4.66	197.06	2.45	245.60	3.56

LEGEND

Cap. — Capacity (Tons)
 EFT — Entering Fluid Temperature
 LFT — Leaving Fluid Temperature
 LTD — Leaving Temperature Difference
 PD — Pressure Drop (psig)
 SET — Refrigerant Saturated Evaporator Temperature

NOTES:

- Fouling factor is 0.0005.
- Shaded selections are 2-pass. All other selections are 4-pass.
- LTD = LFT - SET
- Range = EFT - LFT



BRINE RATINGS — R-134a (cont)
0° F SET, PROPYLENE GLYCOL SOLUTION (40%)

UNIT 10RT	6 F RANGE				8 F RANGE				10 F RANGE				12 F RANGE			
	8 F LTD		10 F LTD		8 F LTD		10 F LTD		8 F LTD		10 F LTD		8 F LTD		10 F LTD	
	Cap.	PD	Cap.	PD	Cap.	PD	Cap.	PD	Cap.	PD	Cap.	PD	Cap.	PD	Cap.	PD
0401-A	—	—	—	—	—	—	—	—	—	—	—	—	—	—	—	—
0501-A	—	—	1.88	1.52	—	—	—	—	—	—	—	—	—	—	—	—
0501-B	—	—	3.87	2.90	—	—	3.59	1.53	—	—	3.42	1.05	—	—	3.26	0.87
0401-C	—	—	—	—	—	—	—	—	—	—	—	—	—	—	—	—
0501-C	—	—	5.98	2.22	—	—	5.54	1.23	—	—	5.29	0.96	—	—	5.06	0.81
0602-C	—	—	6.42	1.60	—	—	6.12	1.05	—	—	5.82	0.85	—	—	5.66	0.75
0702-C	5.64	1.56	7.63	2.42	5.48	1.04	7.39	1.44	5.32	0.86	7.22	1.06	5.46	0.79	7.18	0.91
0704-D	—	—	9.08	0.92	—	—	8.66	0.75	—	—	8.55	0.68	—	—	8.54	0.64
0804-D	7.67	0.88	10.69	1.12	7.82	0.76	10.13	0.85	7.94	0.69	10.07	0.75	7.97	0.65	10.09	0.69
0904-D	8.97	1.08	15.85	2.46	8.84	0.87	11.25	1.01	9.00	0.78	11.08	0.85	9.16	0.72	11.24	0.77
0804-E	12.16	1.02	16.62	1.46	12.16	0.84	15.93	0.99	12.20	0.75	15.47	0.83	12.41	0.70	15.51	0.75
1004-F	27.07	2.87	38.83	4.57	25.99	1.83	37.59	2.83	25.88	1.36	36.38	1.96	18.87	0.79	35.27	1.45
1004-G	37.69	2.97	53.01	4.70	36.45	1.85	51.58	2.86	36.40	1.36	50.13	1.96	36.25	1.06	49.88	1.49
1003-H	54.30	4.30	75.21	6.93	54.33	2.76	74.77	4.30	54.34	1.98	73.23	2.89	54.25	1.51	73.06	2.17
1003-J	67.51	3.83	95.19	6.39	67.52	2.46	93.17	3.82	67.56	1.77	92.73	2.67	67.44	1.36	92.51	2.01
0601-B	—	—	3.87	2.90	—	—	3.59	1.53	—	—	3.42	1.05	—	—	3.26	0.87
0503-D	—	—	8.85	1.11	—	—	8.18	0.85	—	—	7.94	0.74	—	—	7.93	0.69
0604-D	—	—	—	—	—	—	—	—	—	—	—	—	—	—	—	—
0702-D	8.23	1.47	11.43	2.39	7.98	1.00	10.94	1.39	7.96	0.86	10.66	1.04	7.99	0.78	10.40	0.88
0806-E	—	—	13.36	0.90	—	—	13.15	0.76	—	—	13.11	0.68	—	—	13.10	0.64
1104-F	31.86	4.10	43.51	6.17	31.26	2.65	42.19	3.79	30.66	1.90	41.02	2.60	30.52	1.49	40.80	1.99
1104-G	43.07	4.16	59.33	6.60	43.03	2.71	57.88	3.98	42.94	1.97	57.61	2.81	42.85	1.52	57.48	2.13
0903-H	33.23	1.82	64.87	4.68	33.30	1.22	64.47	2.94	33.61	0.93	62.89	1.99	33.96	0.74	61.36	1.45
1205-H	57.49	3.51	77.30	5.20	57.38	2.32	75.36	3.19	55.64	1.63	74.96	2.29	55.48	1.27	73.32	1.69
1104-J	71.37	3.21	98.84	5.13	71.35	2.09	96.56	3.11	71.26	1.52	96.14	2.19	71.13	1.17	94.26	1.60
1204-J	81.25	4.70	106.07	6.88	82.28	3.10	105.00	4.22	81.33	2.18	104.90	2.97	82.31	1.71	104.97	2.24
0902-L	89.64	2.68	129.58	4.73	92.40	1.80	129.72	2.91	92.89	1.28	129.58	2.01	93.02	0.97	129.58	1.50
1002-L	109.04	4.43	149.87	7.31	109.91	2.78	149.93	4.46	112.88	2.04	150.22	3.06	113.24	1.54	150.64	2.27
1103-L	114.54	4.95	153.70	7.74	116.68	3.21	153.76	4.77	119.56	2.39	154.08	3.31	119.98	1.81	154.55	2.47
1203-L	127.08	5.80	163.52	8.55	130.57	3.83	165.41	5.36	131.32	2.69	167.52	3.77	134.72	2.12	170.90	2.91

-10 F SET, PROPYLENE GLYCOL SOLUTION (50%)

UNIT 10RT	6 F RANGE				8 F RANGE				10 F RANGE				12 F RANGE			
	8 F LTD		10 F LTD		8 F LTD		10 F LTD		8 F LTD		10 F LTD		8 F LTD		10 F LTD	
	Cap.	PD	Cap.	PD	Cap.	PD	Cap.	PD	Cap.	PD	Cap.	PD	Cap.	PD	Cap.	PD
0401-A	—	—	—	—	—	—	—	—	—	—	—	—	—	—	—	—
0501-A	—	—	—	—	—	—	—	—	—	—	—	—	—	—	—	—
0501-B	—	—	—	—	—	—	—	—	—	—	—	—	—	—	—	—
0401-C	—	—	—	—	—	—	—	—	—	—	—	—	—	—	—	—
0501-C	—	—	—	—	—	—	—	—	—	—	—	—	—	—	—	—
0602-C	—	—	—	—	—	—	—	—	—	—	—	—	—	—	—	—
0702-C	—	—	5.30	2.31	—	—	5.22	1.53	—	—	5.16	1.11	—	—	5.16	1.00
0704-D	—	—	—	—	—	—	—	—	—	—	—	—	—	—	—	—
0804-D	—	—	7.81	1.19	—	—	7.66	0.96	—	—	7.64	0.84	—	—	7.64	0.76
0904-D	9.11	1.34	9.50	2.11	8.89	1.03	8.47	1.10	—	—	8.48	0.97	—	—	8.51	0.87
0804-E	—	—	12.13	1.56	—	—	11.93	1.10	—	—	11.76	0.93	—	—	11.76	0.84
1004-F	16.24	4.38	25.85	5.35	15.75	3.36	25.27	3.82	14.38	2.42	17.06	2.32	14.67	2.14	17.35	2.01
1004-G	21.25	4.01	36.30	5.21	20.52	3.01	34.69	3.56	19.29	2.06	34.15	2.72	19.70	1.80	34.11	2.23
1003-H	27.06	4.99	52.69	6.99	26.22	2.77	50.59	4.62	26.81	2.29	48.64	3.38	27.59	1.98	48.64	2.72
1003-J	33.54	4.61	67.24	6.55	32.56	2.50	64.65	4.33	33.51	2.09	60.61	3.05	34.28	1.79	60.60	2.45
0601-B	—	—	—	—	—	—	—	—	—	—	—	—	—	—	—	—
0503-D	—	—	—	—	—	—	—	—	—	—	—	—	—	—	—	—
0604-D	—	—	—	—	—	—	—	—	—	—	—	—	—	—	—	—
0702-D	—	—	7.87	2.27	—	—	7.74	1.50	—	—	7.72	1.11	—	—	7.71	1.00
0806-E	—	—	—	—	—	—	—	—	—	—	—	—	—	—	—	—
1104-F	17.95	5.66	29.96	7.15	17.33	4.26	28.71	4.91	16.95	3.52	28.20	3.77	16.66	2.97	28.17	3.11
1104-G	23.60	5.38	41.38	7.07	22.66	3.96	39.57	4.75	22.17	3.23	38.80	3.59	21.78	2.69	38.81	2.92
0903-H	24.37	2.92	44.36	4.88	24.73	2.27	29.78	2.36	25.15	1.88	30.20	1.91	25.60	1.62	30.66	1.61
1205-H	31.59	4.89	54.23	6.11	30.52	3.75	52.08	4.20	29.83	3.02	52.00	3.28	29.31	2.55	52.05	2.70
1104-J	36.64	4.04	69.76	5.58	35.24	3.04	66.11	3.67	34.45	2.47	64.71	2.77	34.58	1.63	64.76	2.24
1204-J	56.38	5.71	77.06	7.56	56.37	4.12	74.21	5.02	56.65	3.23	71.66	3.67	57.78	2.71	71.77	2.96
0902-L	48.83	2.43	93.01	4.67	50.12	1.84	89.81	3.04	51.17	1.49	86.84	2.20	52.59	1.27	86.27	1.75
1002-L	50.91	3.07	109.68	7.03	52.46	2.31	106.42	4.51	54.14	1.88	104.39	3.27	55.83	1.60	102.65	2.53
1103-L	55.90	5.82	113.12	7.95	53.64	4.02	109.42	5.17	54.36	2.26	108.56	3.87	56.21	1.94	105.49	2.96
1203-L	93.55	6.76	122.64	8.89	92.10	4.60	120.61	5.84	91.88	3.51	118.88	4.25	93.85	2.89	118.61	3.35

LEGEND

Cap. — Capacity (Tons) LTD — Leaving Temperature Difference
EFT — Entering Fluid Temperature PD — Pressure Drop (psig)
LFT — Leaving Fluid Temperature SET — Refrigerant Saturated Evaporator Temperature

NOTES:

- Fouling factor is 0.0005.
- Shaded selections are 2-pass. All other selections are 4-pass.
- LTD = LFT - SET
- Range = EFT - LFT

Performance data (cont)



BRINE RATINGS — R-507/404A 20 F SET, PROPYLENE GLYCOL SOLUTION (20%)

UNIT 10RT	6 F RANGE				8 F RANGE				10 F RANGE				12 F RANGE			
	8 F LTD		10 F LTD		8 F LTD		10 F LTD		8 F LTD		10 F LTD		8 F LTD		10 F LTD	
	Cap.	PD	Cap.	PD	Cap.	PD	Cap.	PD	Cap.	PD	Cap.	PD	Cap.	PD	Cap.	PD
0401-A	2.51	1.08	4.54	3.08	2.51	0.83	4.53	1.76	2.27	0.69	4.30	1.10	2.39	0.66	4.29	0.92
0501-A	4.59	4.00	6.87	8.80	4.74	2.44	6.88	5.01	4.89	1.69	6.87	3.24	4.89	1.18	6.88	2.27
0501-B	9.02	8.11	11.23	12.37	9.32	4.93	11.85	7.82	9.37	3.18	12.47	5.58	7.47	1.44	13.07	4.29
0401-C	7.90	1.36	13.58	3.87	8.27	1.00	13.60	2.21	8.30	0.82	13.62	1.43	8.32	0.73	13.59	1.08
0501-C	13.45	4.76	13.47	4.76	14.34	3.11	15.30	3.52	14.43	2.01	16.27	2.56	14.85	1.50	17.23	2.01
0602-C	15.13	3.81	19.77	6.41	15.44	2.25	20.90	4.09	15.69	1.51	21.02	2.64	15.74	1.12	22.12	2.06
0702-C	16.48	5.15	—	—	17.90	3.43	30.31	9.55	19.28	2.57	31.69	6.74	20.62	2.06	32.91	5.13
0704-D	22.31	1.81	32.05	3.59	21.90	1.08	31.99	2.06	21.41	0.86	31.95	1.34	20.18	0.74	31.91	1.05
0804-D	25.77	2.69	—	—	26.95	1.69	46.39	4.85	27.05	1.14	46.45	3.15	28.16	0.99	46.35	2.21
0904-D	35.99	6.25	55.52	14.35	37.41	3.85	56.79	8.62	38.78	2.69	56.84	5.60	38.84	1.89	57.93	4.12
0804-E	41.18	4.08	—	—	43.04	2.56	71.37	6.68	44.84	1.81	71.53	4.35	44.97	1.27	71.42	3.07
1004-F	68.53	6.54	96.31	12.61	72.92	4.30	98.74	7.59	75.36	3.00	100.91	5.18	77.48	2.26	—	—
1004-G	87.77	6.41	121.49	11.81	93.89	4.21	127.28	7.44	99.64	3.10	130.56	5.08	102.74	2.33	133.79	3.74
1003-H	120.22	9.53	—	—	131.18	6.51	175.54	11.41	138.82	4.72	—	—	145.86	3.69	—	—
1003-J	153.01	8.98	—	—	166.63	6.10	222.24	10.55	176.13	4.41	—	—	184.86	3.43	—	—
0601-B	9.02	8.11	11.23	12.37	9.32	4.93	11.85	7.82	9.37	3.18	12.47	5.58	7.47	1.44	13.07	4.29
0503-D	21.69	2.70	25.50	3.65	21.79	1.54	27.15	2.38	21.74	1.08	27.22	1.54	21.71	0.91	27.29	1.13
0604-D	17.25	1.05	19.87	1.24	16.77	0.80	24.61	1.12	15.41	0.68	24.03	0.89	15.40	0.63	23.49	0.76
0702-D	23.49	4.51	42.66	14.46	25.63	3.05	44.74	9.07	27.72	2.31	46.79	6.42	29.75	1.87	46.92	4.50
0806-E	31.82	1.99	52.27	4.99	29.07	1.09	48.68	2.56	29.00	0.90	45.13	1.47	28.99	0.79	39.40	0.99
1104-F	79.33	9.88	—	—	84.22	6.43	—	—	86.72	4.46	—	—	89.19	3.34	—	—
1104-G	102.02	10.03	—	—	108.86	6.51	—	—	112.61	4.51	—	—	118.41	3.55	—	—
0903-H	99.05	5.64	143.25	11.44	108.86	3.93	150.58	7.17	115.87	2.89	157.19	5.08	122.22	2.28	163.48	3.89
1205-H	137.55	7.90	—	—	146.07	5.14	—	—	150.67	3.57	—	—	155.18	2.67	—	—
1104-J	167.47	7.62	—	—	178.29	4.91	—	—	187.78	3.57	—	—	193.48	2.65	—	—
1204-J	187.36	11.31	—	—	198.77	7.26	—	—	—	—	—	—	—	—	—	—
0902-L	173.48	4.74	—	—	197.01	3.52	272.45	6.46	210.77	2.58	290.37	4.76	223.39	2.03	303.06	3.62
1002-L	212.55	8.41	—	—	233.85	5.76	—	—	258.86	4.64	334.84	7.53	272.90	3.61	—	—
1103-L	239.42	10.58	—	—	262.06	7.21	—	—	277.53	5.22	—	—	292.37	4.07	—	—
1203-L	268.70	13.22	—	—	289.92	8.72	—	—	306.51	6.30	—	—	—	—	—	—

10 F SET, PROPYLENE GLYCOL SOLUTION (30%)

UNIT 10RT	6 F RANGE				8 F RANGE				10 F RANGE				12 F RANGE			
	8 F LTD		10 F LTD		8 F LTD		10 F LTD		8 F LTD		10 F LTD		8 F LTD		10 F LTD	
	Cap.	PD	Cap.	PD	Cap.	PD	Cap.	PD	Cap.	PD	Cap.	PD	Cap.	PD	Cap.	PD
0401-A	—	—	2.40	1.20	—	—	2.27	0.90	—	—	2.15	0.75	—	—	2.03	0.66
0501-A	2.61	1.79	4.42	4.17	2.54	1.11	3.92	2.08	2.47	0.89	3.91	1.45	2.46	0.79	3.77	1.09
0501-B	5.88	4.01	8.41	7.80	5.44	2.18	8.10	4.12	5.58	1.58	7.45	2.45	5.57	1.17	7.44	1.81
0401-C	4.33	0.89	7.50	1.50	4.33	0.75	7.18	1.02	4.33	0.67	7.16	0.87	4.34	0.63	7.14	0.77
0501-C	7.70	1.99	13.40	5.35	8.12	1.40	12.93	2.85	8.16	1.08	11.53	1.61	8.16	0.93	11.52	1.21
0602-C	9.05	1.77	13.97	3.64	9.28	1.17	12.76	1.88	9.28	0.97	12.54	1.27	9.03	0.83	12.29	1.03
0702-C	12.00	3.17	19.21	7.75	11.60	1.91	19.11	4.43	11.61	1.33	16.40	2.23	11.63	1.07	16.46	1.66
0704-D	13.32	1.02	19.10	1.62	12.84	0.80	18.15	1.03	12.79	0.71	17.61	0.84	12.31	0.64	17.11	0.74
0804-D	16.00	1.37	26.90	3.25	15.95	0.99	23.30	1.56	15.87	0.84	23.22	1.12	15.62	0.74	23.17	0.96
0904-D	19.40	2.32	36.05	6.89	19.43	1.42	30.53	2.97	19.47	1.07	30.51	2.04	20.08	0.94	30.40	1.49
0804-E	25.20	1.96	43.01	4.88	24.85	1.17	37.31	2.31	24.44	0.96	35.68	1.45	24.39	0.84	35.64	1.12
1004-F	49.20	4.53	70.96	8.36	44.91	2.33	70.51	4.99	46.87	1.72	68.23	3.17	46.96	1.26	63.47	2.05
1004-G	63.89	4.37	94.24	8.61	60.65	2.44	94.22	5.11	63.46	1.81	93.87	3.43	63.74	1.32	85.16	2.09
1003-H	93.75	7.20	134.54	13.84	97.27	4.60	135.13	8.12	97.84	3.10	135.26	5.40	93.49	2.11	135.42	3.88
1003-J	116.52	6.39	167.72	12.29	120.81	4.08	171.54	7.58	125.00	2.94	171.61	5.03	116.11	1.87	171.76	3.62
0601-B	5.88	4.01	8.41	7.80	5.44	2.18	8.10	4.12	5.58	1.58	7.45	2.45	5.57	1.17	7.44	1.81
0503-D	12.65	1.28	18.18	2.20	12.26	0.93	18.09	1.38	12.23	0.80	17.28	1.01	11.83	0.71	17.17	0.88
0604-D	9.55	0.76	14.99	1.04	9.10	0.65	14.44	0.81	9.04	0.60	13.61	0.70	8.64	0.57	13.12	0.64
0702-D	16.60	2.75	27.62	6.95	17.05	1.82	25.61	3.40	17.01	1.26	23.37	2.04	17.01	1.04	23.44	1.52
0806-E	19.59	1.09	27.22	1.73	18.73	0.83	26.16	1.08	18.26	0.71	25.22	0.87	17.76	0.65	24.34	0.75
1104-F	58.49	6.97	81.44	12.41	58.43	4.21	79.33	6.95	54.91	2.55	78.89	4.67	55.91	1.93	76.82	3.20
1104-G	77.43	7.24	107.27	12.85	79.03	4.51	107.18	7.58	79.17	3.05	107.15	5.06	75.83	2.08	106.06	3.56
0903-H	75.04	4.15	115.25	8.96	78.03	2.71	115.51	5.29	74.68	1.71	115.57	3.53	75.28	1.25	115.37	2.55
1205-H	102.02	5.59	141.16	9.94	97.22	3.14	139.37	5.73	97.93	2.13	137.59	3.75	99.80	1.61	128.92	2.43
1104-J	127.02	5.48	177.84	9.95	131.38	3.51	177.76	5.86	121.99	2.07	177.67	3.91	124.45	1.57	177.67	2.82
1204-J	143.96	8.16	—	—	148.96	5.19	—	—	149.20	3.50	—	—	142.84	2.38	—	—
0902-L	142.13	3.94	210.66	7.95	148.73	2.53	221.78	5.17	155.08	1.83	223.30	3.43	148.83	1.24	228.66	2.58
1002-L	177.51	7.10	—	—	185.42	4.49	259.57	8.28	197.83	3.41	266.06	5.73	199.11	2.46	272.58	4.29
1103-L	194.45	8.45	263.93	14.47	202.67	5.36	270.63	8.91	209.82	3.82	277.24	6.20	211.00	2.76	—	—
1203-L	219.84	10.57	—	—	228.99	6.65	—	—	236.51	4.72	—	—	244.03	3.61	—	—

LEGEND

Cap. — Capacity (Tons)
 EFT — Entering Fluid Temperature
 LFT — Leaving Fluid Temperature
 LTD — Leaving Temperature Difference
 PD — Pressure Drop (psig)
 SET — Refrigerant Saturated Evaporator Temperature

NOTES:

- Fouling factor is 0.0005.
- Shaded selections are 2-pass. All other selections are 4-pass.
- LTD = LFT - SET
- Range = EFT - LFT



BRINE RATINGS — R-507/404A (cont)
0° F SET, PROPYLENE GLYCOL SOLUTION (40%)

UNIT 10RT	6 F RANGE				8 F RANGE				10 F RANGE				12 F RANGE			
	8 F LTD		10 F LTD		8 F LTD		10 F LTD		8 F LTD		10 F LTD		8 F LTD		10 F LTD	
	Cap.	PD	Cap.	PD	Cap.	PD	Cap.	PD	Cap.	PD	Cap.	PD	Cap.	PD	Cap.	PD
0401-A	—	—	—	—	—	—	—	—	—	—	—	—	—	—	—	—
0501-A	—	—	2.29	2.10	—	—	1.97	1.08	—	—	1.80	0.85	—	—	1.80	0.77
0501-B	3.10	2.02	4.96	4.43	2.80	1.09	4.51	2.26	2.65	0.88	4.33	1.45	2.65	0.79	4.03	1.03
0401-C	—	—	4.13	1.08	—	—	3.58	0.78	—	—	—	—	—	—	3.56	0.66
0501-C	4.33	1.37	7.43	3.11	4.09	0.95	6.94	1.76	4.06	0.82	6.48	1.14	4.09	0.75	6.23	0.94
0602-C	5.23	1.21	8.16	2.34	4.81	0.88	7.58	1.31	4.81	0.78	7.26	1.00	4.93	0.72	6.72	0.82
0702-C	7.19	2.27	10.25	3.88	6.86	1.32	9.64	2.18	6.68	1.01	9.28	1.43	6.49	0.86	8.95	1.08
0704-D	7.43	0.82	11.25	1.09	7.43	0.71	10.39	0.82	7.45	0.66	10.10	0.72	7.47	0.62	9.87	0.66
0804-D	9.52	1.02	14.05	1.66	9.20	0.82	13.14	1.04	9.45	0.74	12.28	0.83	9.45	0.69	11.97	0.74
0904-D	11.47	1.48	18.70	3.18	11.09	1.01	17.29	1.75	11.03	0.86	16.55	1.13	11.05	0.78	15.30	0.92
0804-E	15.05	1.26	21.96	2.28	14.49	0.93	20.59	1.28	14.51	0.81	19.63	0.97	14.52	0.74	18.73	0.82
1004-F	29.41	3.21	44.51	5.65	28.27	2.03	42.24	3.34	28.14	1.51	40.14	2.21	27.13	1.13	39.83	1.70
1004-G	40.77	3.31	60.46	5.81	39.46	2.06	57.74	3.38	39.39	1.50	57.45	2.39	39.34	1.17	55.97	1.74
1003-H	59.88	5.00	86.48	8.75	59.87	3.18	86.07	5.37	59.93	2.26	85.80	3.71	59.91	1.72	82.70	2.59
1003-J	74.32	4.45	109.10	8.02	74.29	2.84	106.89	4.76	74.37	2.02	106.60	3.30	74.37	1.54	104.41	2.38
0601-B	3.10	2.02	4.96	4.43	2.80	1.09	4.51	2.26	2.65	0.88	4.33	1.45	2.65	0.79	4.03	1.03
0503-D	6.78	0.93	10.91	1.53	6.57	0.77	9.98	0.99	6.59	0.70	9.48	0.81	6.78	0.66	9.07	0.72
0604-D	—	—	8.17	0.80	—	—	7.70	0.68	—	—	7.68	0.63	—	—	7.50	0.60
0702-D	10.17	2.03	14.97	3.63	9.64	1.15	14.34	2.15	9.57	0.96	13.58	1.36	9.33	0.84	13.05	1.05
0806-E	11.48	0.83	16.37	1.06	11.48	0.72	15.47	0.82	11.67	0.66	15.43	0.73	11.69	0.62	15.04	0.67
1104-F	35.71	4.82	51.15	7.94	34.53	3.01	49.73	4.83	34.42	2.20	48.42	3.30	33.31	1.63	47.13	2.42
1104-G	49.33	5.15	69.53	8.46	49.24	3.31	69.11	5.26	49.24	2.38	67.54	3.54	47.88	1.74	66.02	2.57
0903-H	47.61	3.03	71.65	5.50	47.52	1.96	71.16	3.42	47.51	1.42	68.30	2.23	47.52	1.10	68.04	1.68
1205-H	64.48	4.10	92.82	6.90	64.24	2.68	90.62	4.20	64.15	1.95	88.38	2.87	62.26	1.45	86.31	2.10
1104-J	81.06	3.91	116.43	6.69	80.96	2.52	112.22	3.88	80.99	1.81	111.65	2.72	80.85	1.39	109.29	1.98
1204-J	93.79	5.84	129.78	9.53	93.85	3.72	127.33	5.69	93.98	2.64	126.65	3.95	93.77	2.01	126.29	2.95
0902-L	95.63	2.97	142.34	5.53	98.52	1.98	142.29	3.37	99.02	1.40	142.51	2.32	101.85	1.11	142.46	1.72
1002-L	119.57	5.12	171.07	9.01	122.96	3.33	171.66	5.52	123.76	2.33	171.91	3.76	126.77	1.81	171.88	2.77
1103-L	128.10	5.87	181.03	10.12	131.60	3.86	183.81	6.37	135.14	2.83	180.99	4.23	135.33	2.13	180.93	3.13
1203-L	147.80	7.37	203.87	12.44	154.70	4.99	203.95	7.58	155.51	3.48	204.18	5.18	155.91	2.60	204.64	3.81

-20 F SET, PROPYLENE GLYCOL SOLUTION (50%)

UNIT 10RT	6 F RANGE				8 F RANGE				10 F RANGE				12 F RANGE			
	8 F LTD		10 F LTD		8 F LTD		10 F LTD		8 F LTD		10 F LTD		8 F LTD		10 F LTD	
	Cap.	PD	Cap.	PD	Cap.	PD	Cap.	PD	Cap.	PD	Cap.	PD	Cap.	PD	Cap.	PD
0401-A	—	—	—	—	—	—	—	—	—	—	—	—	—	—	—	—
0501-A	—	—	—	—	—	—	—	—	—	—	—	—	—	—	—	—
0501-B	—	—	2.40	2.72	—	—	2.32	1.73	—	—	2.25	1.19	—	—	2.18	1.01
0401-C	—	—	—	—	—	—	—	—	—	—	—	—	—	—	—	—
0501-C	—	—	3.82	2.63	—	—	3.61	1.64	—	—	3.59	1.21	—	—	3.59	1.04
0602-C	—	—	4.38	2.19	—	—	4.23	1.42	—	—	4.21	1.11	—	—	4.09	0.95
0702-C	4.02	2.41	5.50	3.32	4.02	1.64	5.47	2.25	4.09	1.24	5.32	1.59	4.03	1.05	5.30	1.24
0704-D	—	—	6.70	1.19	—	—	6.53	0.96	—	—	6.41	0.83	—	—	6.37	0.76
0804-D	5.98	1.26	8.23	1.77	5.97	1.00	7.97	1.15	5.98	0.87	7.81	0.98	5.83	0.78	7.67	0.86
0904-D	7.08	1.92	9.30	2.53	7.09	1.31	9.02	1.64	7.08	1.06	8.97	1.21	7.08	0.94	8.85	1.04
0804-E	9.37	1.66	12.66	2.25	9.36	1.13	12.43	1.50	9.39	0.99	12.19	1.13	9.37	0.88	12.14	0.99
1004-F	17.70	7.42	24.72	8.22	17.71	6.08	24.15	6.24	18.19	5.30	24.10	5.16	18.25	4.69	23.64	4.39
1004-G	24.22	6.53	33.42	7.39	24.28	5.22	33.27	5.59	24.93	4.49	33.24	4.54	25.04	3.92	33.20	3.85
1003-H	34.59	7.65	47.76	9.20	34.72	5.90	46.95	6.61	35.58	4.95	46.96	5.24	35.73	4.23	46.91	4.36
1003-J	43.87	7.06	60.21	8.45	44.05	5.42	60.05	6.17	44.30	4.47	60.08	4.88	45.34	3.87	60.03	4.04
0601-B	—	—	2.40	2.72	—	—	2.32	1.73	—	—	2.25	1.19	—	—	2.18	1.01
0503-D	—	—	6.13	1.63	—	—	5.90	1.12	—	—	5.88	0.95	—	—	5.69	0.84
0604-D	—	—	5.20	0.94	—	—	—	—	—	—	—	—	—	—	—	—
0702-D	5.87	2.32	8.23	3.34	5.87	1.58	7.99	2.17	5.88	1.16	7.86	1.57	5.87	1.03	7.73	1.19
0806-E	—	—	10.53	1.13	—	—	10.27	0.93	—	—	10.06	0.81	—	—	9.80	0.73
1104-F	21.03	9.44	28.68	10.65	21.06	7.53	28.10	7.92	21.59	6.45	28.06	6.45	21.63	5.63	27.96	5.47
1104-G	28.76	8.64	38.83	9.95	28.85	6.74	38.69	7.37	29.57	5.69	38.68	5.90	29.66	4.90	38.02	4.87
0903-H	25.96	5.36	40.00	6.65	26.26	4.34	39.22	4.89	26.31	3.70	39.20	3.95	26.40	3.26	39.22	3.33
1205-H	38.83	8.13	52.99	9.26	39.72	6.55	52.08	6.86	39.91	5.51	52.01	5.57	40.00	4.80	51.15	4.66
1104-J	47.07	6.49	64.70	7.67	48.15	5.13	63.64	5.57	48.42	4.24	63.68	4.45	49.49	3.69	63.55	3.71
1204-J	54.88	8.85	74.16	10.59	55.15	6.73	71.97	7.43	56.45	5.58	71.88	5.87	56.58	4.73	71.80	4.85
0902-L	52.75	4.25	83.30	5.88	53.41	3.31	80.61	4.08	61.63	2.98	81.93	3.25	62.09	2.52	83.22	2.71
1002-L	70.13	6.56	102.56	8.94	71.93	4.97	96.16	5.84	74.99	4.11	98.89	4.66	75.45	3.43	98.92	3.78
1103-L	76.85	8.32	108.67	10.76	78.78	6.34	104.87	7.38	80.77	5.18	105.09	5.73	82.46	4.41	105.12	4.67
1203-L	87.74	9.40	122.74	12.30	89.93	7.05	118.57	8.31	92.13	5.69	118.02	6.38	93.84	4.79	118.25	5.16

LEGEND

Cap. — Capacity (Tons) LTD — Leaving Temperature Difference
EFT — Entering Fluid Temperature PD — Pressure Drop (psig)
LFT — Leaving Fluid Temperature SET — Refrigerant Saturated Evaporator Temperature

NOTES:

- Fouling factor is 0.0005.
- Shaded selections are 2-pass. All other selections are 4-pass.
- LTD = LFT - SET
- Range = EFT - LFT

10RT Direct-Expansion Liquid Coolers

HVAC Guide Specifications

Size Range: **7¹/₂ to 350 tons**

Carrier Part Number: **10RT**

Part 1 — General

1.01 SYSTEM DESCRIPTION

Direct-Expansion Liquid Coolers for built-up systems in commercial applications.

1.02 QUALITY ASSURANCE

- A. Shells shall be steel pipe, ASME specifications SA-53, grade B.
- B. Tubes shall be high-performance seamless copper tube to ASME specifications.
- C. Tube sheets shall be flange quality carbon steel, ASME specification SA-285, grade C.
- D. Heads shall be fabricated ring and cover type steel, ASME specification SA-285, grade C or cast steel, ASME specification SA-216, grade WCA or WCB.
- E. Fluid connections 3-in. IPS and smaller shall terminate as MPT type. Fluid connections 4-in. IPS and larger shall terminate in 150-lb ANSI raised face flanges.
- F. The refrigerant side shall be constructed in accordance with the latest edition of Section VIII, Division I of ASME code for pressure vessels and stamped accordingly.
- G. Both shell and tube sides of coolers shall be pneumatically tested at 1¹/₄ times the design working pressure to comply with ASME code and assure safe reliable service.

1.03 DELIVERY, STORAGE AND HANDLING

Unit will be stored and handled according to manufacturer's instructions.

Part 2 — Products

2.01 EQUIPMENT

- A. General:

Factory assembled direct-expansion liquid coolers. Shells are made of steel pipe. Tubes are seamless copper. Unit has removable heads. The baffles are made of terne plated steel.
- B. Shells shall be shot blasted and cleaned before assembly.
- C. Tubes shall be roller expanded into the double-grooved tube sheet hole to ensure a leak-proof joint.
- D. Baffles shall be hot-rolled steel, terne plated for added corrosion resistance. Six different baffle spacing arrangements are available.
- E. Gaskets shall be die-cut, medium density elastomer in conformance with relevant specifications. Each vessel shall be tested for leaks with pneumatic gas and Freon tests.
- F. Tube side (refrigerant side) design pressure shall be 200 psig at 100 F. Shell side (fluid side) design pressure shall be 150 psig at 120 F.
- G. Refrigerant connections shall be steel, welded to the head and bored to ODS of copper tubing. Thermowell, vent and drain connections shall be provided with ³/₄-in. FPT type fitting.
- H. Head and fluid connections shall be painted with grey enamel paint. Shell shall have a single layer of ³/₄-in. thick Armaflex insulation as standard.
 - I. Two or 4 head passes shall provide sufficiently high refrigerant velocities to ensure positive oil return.
 - J. Lifting lugs and mounting saddles are available as options for ease of handling.
- K. Special Order Features:

For assistance in amending the specifications, contact your Carrier Factory Sales Representative.

 - 1. One, 3 or 4 refrigerant circuits.
 - 2. Double layer of Armaflex insulation.



Manufacturer reserves the right to discontinue, or change at any time, specifications or designs without notice and without incurring obligations.