

**24ANA
Infinity™ Series Air Conditioners
with Puron® Refrigerant
2 to 5 Nominal Tons (Sizes 24 to 60)**



Turn to the Experts.™

Installation Instructions

NOTE: Read the entire instruction manual before starting the installation.

Unless otherwise noted, information in these installation instructions pertain to both 24ANA1 and 24ANA7 series units. Information that is unique to the 24ANA1 series will be identified as such; likewise information that is unique to the 24ANA7 series will also be identified.

SAFETY CONSIDERATIONS

Improper installation, adjustment, alteration, service, maintenance, or use can cause explosion, fire, electrical shock, or other conditions which may cause death, personal injury, or property damage. Consult a qualified installer, service agency, or your distributor or branch for information or assistance. The qualified installer or agency must use factory-authorized kits or accessories when modifying this product. Refer to the individual instructions packaged with the kits or accessories when installing.

Follow all safety codes. Wear safety glasses, protective clothing, and work gloves. Use quenching cloth for brazing operations. Have fire extinguisher available. Read these instructions thoroughly and follow all warnings or cautions included in literature and attached to the unit. Consult local building codes and National Electrical Code (NEC) for special requirements.

Recognize safety information. This is the safety-alert symbol . When you see this symbol on the unit and in instructions or manuals, be alert to the potential for personal injury. Understand these signal words; DANGER, WARNING, and CAUTION. These words are used with the safety-alert symbol. DANGER identifies the most serious hazards which **will** result in severe personal injury or death. WARNING signifies hazards which **could** result in personal injury or death. CAUTION is used to identify unsafe practices which **may** result in minor personal injury or product and property damage. NOTE is used to highlight suggestions which **will** result in enhanced installation, reliability, or operation.

Indoor Thermostat Control Options

Model	Infinity Control	Standard 2-stage Thermostat
24ANA7	Yes	Yes
24ANA1	Yes	No (Emergency Mode Only)



WARNING

ELECTRICAL SHOCK HAZARD

Failure to follow this warning could result in personal injury or death.

Before installing, modifying, or servicing system, main electrical disconnect switch must be in the OFF position. There may be more than 1 disconnect switch. Lock out and tag switch with a suitable warning label.



WARNING

UNIT OPERATION AND SAFETY HAZARD

Failure to follow this warning could result in personal injury, death and/or equipment damage.

Puron refrigerant systems operate at higher pressures than standard R-22 systems. Do not use R-22 service equipment or components on Puron equipment.

INSTALLATION RECOMMENDATIONS

NOTE: In some cases noise in the living area has been traced to gas pulsations from improper installation of equipment.

1. Locate unit away from windows, patios, decks, etc. where unit operation sound may disturb customer.
2. Ensure that vapor and liquid tube diameters are appropriate for unit capacity.
3. Run refrigerant tubes as directly as possible by avoiding unnecessary turns and bends.
4. Leave some slack between structure and unit to absorb vibration.
5. When passing refrigerant tubes through the wall, seal opening with RTV or other pliable silicon-based caulk. (See Fig. 1.)
6. Avoid direct tubing contact with water pipes, duct work, floor joists, wall studs, floors, and walls.
7. Do not suspend refrigerant tubing from joists and studs with a rigid wire or strap which comes in direct contact with tubing (See Fig. 1.)
8. Ensure that tubing insulation is pliable and completely surrounds vapor tube.
9. When necessary, use hanger straps which are 1 in. wide and conform to shape of tubing insulation. (See Fig. 1.)
10. Isolate hanger straps from insulation by using metal sleeves bent to conform to shape of insulation.

When outdoor unit is connected to factory-approved indoor unit, outdoor unit contains system refrigerant charge for operation with ARI rated indoor unit when connected by 15 ft/4.57 m of field-supplied or factory accessory tubing. For proper unit operation, check refrigerant charge using charging information located on control box cover and/or in the Check Charge section of this instruction.

IMPORTANT: Maximum liquid-line size is 3/8-in. OD for all residential applications including long line applications.

IMPORTANT: Always install the factory-supplied liquid-line filter drier. If replacing the filter drier, refer to Product Data Digest for appropriate part number. Obtain replacement filter driers from your distributor or branch.

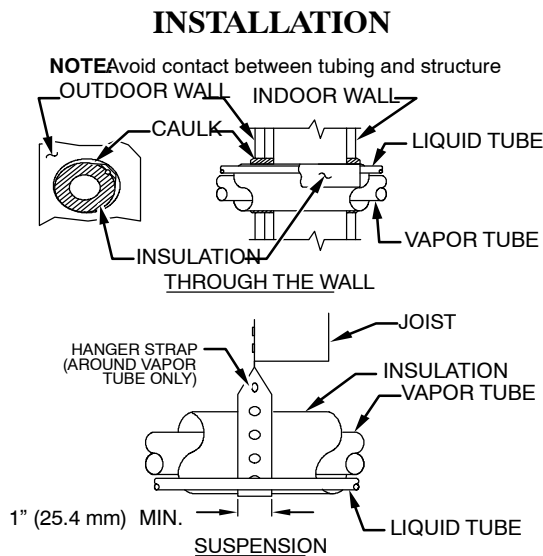

Fig. 1 - Connecting Tube Installation

Specifications for this unit in residential new construction market require the outdoor unit, indoor unit, refrigerant tubing sets, metering device, and filter drier listed in presale literature. There

can be no deviation. Consult the Application Guideline and Service Manual – Air Conditioners and Heat Pumps Using Puron Refrigerant to obtain required unit changes for specific applications and for R-22 retrofit.

Check Equipment and Job Site

Unpack Unit

Move to final location. Remove carton taking care not to damage unit.

Inspect Equipment

File claim with shipping company prior to installation if shipment is damaged or incomplete. Locate unit rating plate on unit corner panel. It contains information needed to properly install unit. Check rating plate to be sure unit matches job specifications.

Install on a Solid, Level Mounting Pad

If conditions or local codes require the unit be attached to pad, tie down bolts should be used and fastened through knockouts provided in unit base pan. Refer to unit mounting pattern in Fig. 2 to determine base pan size and knockout hole location.

For hurricane tie downs, contact distributor for details and PE Certified (Professional Engineer), if required.

On rooftop applications, mount on level platform or frame. Place unit above a load-bearing wall and isolate unit and tubing set. Consult local codes governing rooftop applications.

Roof mounted units exposed to winds above 5 mph may require wind baffles. Consult the Application Guideline and Service Manual - Residential Split System Air Conditioners and Heat Pumps Using Puron Refrigerant for wind baffle construction.

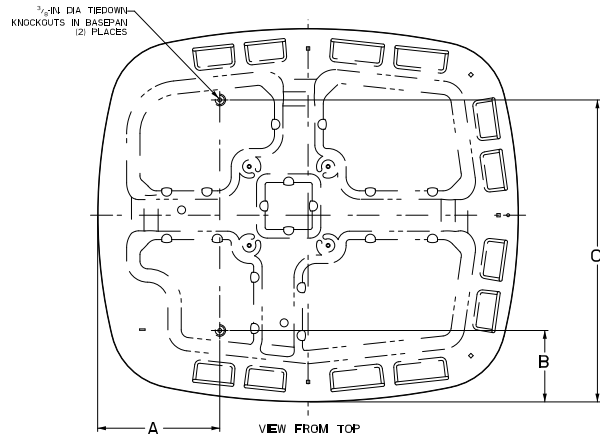

UNIT BASE PAN DIMENSIONS in. (mm)	TIEDOWN KNOCKOUT LOCATIONS in. (mm)		
	A	B	C
36-1/2 x 40 (927.1x1016)	11-5/8 (295.3)	6-13/16 (173.0)	28-3/4 (730.3)

A05177

Fig. 2 - Clearance Requirements

NOTE: Unit must be level to within $\pm 2^\circ$, $\pm 3/8$ in./ft. (9.53 mm/m) per compressor manufacturer specifications.

Clearance Requirements

When installing, allow sufficient space for airflow clearance, wiring, refrigerant piping, and service. Allow 30 in. (762 mm) clearance to service end of unit and 48 in. (1219.2 mm) above unit. For proper airflow, a 6 in. (152.4 mm) clearance on 1 side of unit and 12 in. (304.8 mm) on all remaining sides must be maintained. Maintain a distance of 24 in. (609.6 mm) between units. Position so water, snow, or ice from roof or eaves cannot fall directly on unit.

On rooftop applications, locate unit at least 6 in. (152.4 mm) above roof surface.

Operating Ambient

The minimum outdoor operating ambient in cooling mode is 55°F/12.78°C without low ambient cooling enabled, and the maximum outdoor operating ambient in cooling mode is 125°F/51.67°C. On Infinity communicating systems only, for both 24ANA1 and 24ANA7 models, low ambient cooling is available to 0°F/-17.78°C.

Make Piping Connections

WARNING

PERSONAL INJURY AND ENVIRONMENTAL HAZARD

Failure to follow this warning could result in personal injury or death.

Relieve pressure and recover all refrigerant before system repair or final unit disposal. Use all service ports and open all flow-control devices, including solenoid valves.

CAUTION

UNIT DAMAGE HAZARD

Failure to follow this caution may result in equipment damage or improper operation.

Do not leave system open to atmosphere any longer than minimum required for installation. POE oil in compressor is extremely susceptible to moisture absorption. Always keep ends of tubing sealed during installation.

CAUTION

UNIT DAMAGE HAZARD

Failure to follow this caution may result in equipment damage or improper operation.

If ANY refrigerant tubing is buried, provide a 6 in. (152.4 mm) vertical rise at service valve. Refrigerant tubing lengths up to 36 in. (914.4 mm) may be buried without further special consideration. Do not bury lines longer than 36 in. (914.4 mm).

Outdoor units may be connected to indoor section using field-supplied refrigerant grade tubing of correct size and condition. For tubing requirements beyond 80 ft/24.38 m, substantial capacity and performance losses can occur. Following the recommendations in the Application Guideline and Service Manual-Residential Split-System Air Conditioners and Heat Pumps Using Puron Refrigerant will reduce these losses. Refer to Table 1 for field tubing diameters. Refer to Table 2 for accessory requirements.

There are no buried-line applications greater than 36 in. (914.4 mm).

If refrigerant tubes or indoor coil are exposed to atmosphere, they must be evacuated to 500 microns to eliminate contamination and moisture in the system.

Outdoor Unit Connected to Factory Approved Indoor Unit:

Outdoor unit contains correct system refrigerant charge for operation with factory approved ARI rated indoor unit with highest sales volume when connected by 15 ft/4.57 m of field-supplied or factory-accessory tubing, and factory supplied filter drier. Check refrigerant charge for maximum efficiency.

24ANA

Table 1 – Refrigerant Connections and Recommended Liquid and Vapor Tube Diameters (in.)

UNIT SIZE	LIQUID		RATED VAPOR*	
	Connection Diameter	Tube Diameter	Connection Diameter	Tube Diameter
24ANA724	3/8	3/8	5/8	5/8
24ANA736	3/8	3/8	3/4	3/4
24ANA748	3/8	3/8	7/8	7/8
24ANA760	3/8	3/8	7/8	1 – 1/8
24ANA124 24ANA136 24ANA148	3/8	3/8	7/8	7/8
24ANA160	3/8	3/8	7/8	1 – 1/8

* Units are rated with 25 ft. (7.6 m) of lineset. See Product Data sheet for performance data when using different size and length linesets.

Notes:

1. Tube diameters are for total equivalent lengths up to 80 ft. (24.38 m)
2. Do not apply capillary tube or fixed orifice indoor coils to these units.
3. For Tubing Set lengths between 80 and 200 ft. (24.38 and 60.96 m) horizontal or 20 ft. (6.10 m) vertical differential (250 ft./76.2 m Total Equivalent Length), refer to the Longline Guideline— Air Conditioners and Heat Pumps using Puron® Refrigerant.



This product has been designed and manufactured to meet Energy Star® criteria for energy efficiency when matched with appropriate coil components. However, proper refrigerant charge and proper air flow are critical to achieve rated capacity and efficiency. Installation of this product should follow all manufacturing refrigerant charging and air flow instructions. **Failure to confirm proper charge and air flow may reduce energy efficiency and shorten equipment life.**

Table 2 – Accessory Usage

Accessory	REQUIRED FOR LOW-AMBIENT COOLING APPLICATIONS (Below 55°F/12.8°C)	REQUIRED FOR LONG LINE APPLICATIONS* (Over 80 ft/24.38 m)	REQUIRED FOR SEA COAST APPLICATIONS (Within 2 miles/3.22 km)
Crankcase Heater	Standard	Standard	Standard
Evaporator Freeze Protection	Standard with Infinity Control (Low Ambient not allowed with non-communicating Thermostat)	No	No
Winter Start Control	Standard with Infinity Control (Low Ambient not allowed with Non-Communicating Thermostat)	No	No
Accumulator	No	No	No
Compressor Start Assist Capacitor and Relay‡	Standard on 24ANA7 models. Not required on 24ANA1 models since compressor always starts unloaded.	Standard on 24ANA7 models. Not required on 24ANA1 models since compressor always starts unloaded.	Standard on 24ANA7 models. Not required on 24ANA1 models since compressor always starts unloaded.
Low-ambient Control	Standard with Infinity Control (Low Ambient not allowed with non-communicating thermostat)	No	No
Support Feet	Recommended	No	Recommended
Liquid Line Solenoid Valve	No	No	No
Puron Balance Port Hard Shut-off TXV	Yes†	Yes†	Yes†

* For Tubing Set lengths between 80 and 200 ft. (24.38 and 60.96 m) horizontal or 20 ft. (6.10 m) vertical differential (250 ft./76.2 m Total Equivalent Length), refer to the Longline Guideline – Air Conditioners and Heat Pumps using Puron®

† Required on all indoor units. Standard on all new Puron fan coils and furnace coils.

‡ Information is specific to 24ANA7 and 24ANA1 models.

24ANA

Install Liquid-Line Filter Drier Indoor

⚠ CAUTION

UNIT DAMAGE HAZARD

Failure to follow this caution may result in equipment damage or improper operation.

Installation of filter drier in liquid line is required.

Refer to Fig. 3 and install filter drier as follows:

1. Braze 5 in. (127 mm) liquid tube to the indoor coil.
2. Wrap filter drier with damp cloth.
3. Braze filter drier to above 5 in. (127 mm) liquid tube. Flow arrow must point towards indoor coil.
4. Connect and braze liquid refrigerant tube to the filter drier.

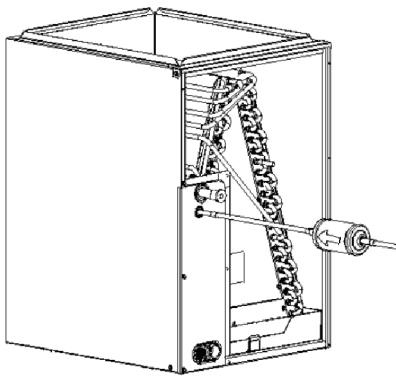

A05178

Fig. 3 – Liquid Line Filter Drier

Refrigerant Tubing Connection Outdoor

Connect vapor tube to fitting on outdoor unit vapor service valves (see Table 1.) Connect and braze the 3/8 in. coupling (provided with the filter drier) to the liquid service valve and connect and braze the liquid tubing to the other end of this coupling. Use refrigerant grade tubing.

Sweat Connection

⚠ CAUTION

UNIT DAMAGE HAZARD

Failure to follow this caution may result in equipment damage or improper operation.

- Use a brazing shield
- Wrap service valves with wet cloth or heat sink material.

Use refrigerant grade tubing. Service valves are closed from factory and ready for brazing. After wrapping service valve with a wet cloth, braze sweat connections using industry accepted methods and materials. Consult local code requirements. Refrigerant tubing and indoor coil are now ready for leak testing. This check should include all field and factory joints.

Evacuate Refrigerant Tubing and Indoor Coil

⚠ CAUTION

UNIT DAMAGE HAZARD

Failure to follow this caution may result in equipment damage or improper operation.

Never use the system compressor as a vacuum pump.

Refrigerant tubes and indoor coil should be evacuated using the recommended deep vacuum method of 500 microns. The alternate triple evacuation method may be used. See Service Manual for triple evacuation method. Always break a vacuum with dry nitrogen.°

Deep Vacuum Method

The deep vacuum method requires a vacuum pump capable of pulling a vacuum of 500 microns and a vacuum gage capable of accurately measuring this vacuum depth. The deep vacuum method is the most positive way of assuring a system is free of air and liquid water. (See Fig. 4)

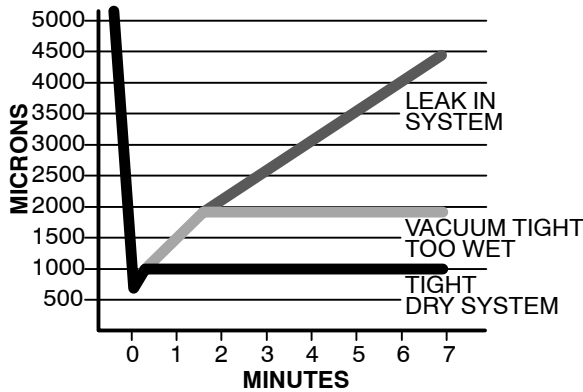

Fig. 4 - Deep Vacuum Graph

A95424

Final Tubing Check

IMPORTANT: Check to be certain factory tubing on both indoor and outdoor unit has not shifted during shipment. Ensure tubes are not rubbing against each other or any sheet metal. Pay close attention to feeder tubes, making sure wire ties on feeder tubes are secure and tight.

Make Electrical Connections

⚠ WARNING

ELECTRICAL SHOCK HAZARD

Failure to follow this warning could result in personal injury or death.

Do not supply power to unit with compressor terminal box cover removed.

Be sure field wiring complies with local and national fire, safety, and electrical codes, and voltage to system is within limits shown on unit rating plate. Contact local power company for correction of improper voltage. See unit rating plate for recommended circuit protection device.

NOTE: Operation of unit on improper line voltage constitutes abuse and could affect unit reliability. See unit rating plate. Do not install unit in system where voltage may fluctuate above or below permissible limits.

NOTE: Use copper wire only between disconnect switch and unit.

NOTE: Install branch circuit disconnect of adequate size per NEC to handle unit starting current. Locate disconnect within sight from and readily accessible from unit, per Section 440-14 of NEC.

Route Ground and Power Wires

Remove access panel to gain access to unit wiring. Extend wires from disconnect through power wiring hole provided and into unit control box.

⚠ WARNING

ELECTRICAL SHOCK HAZARD

Failure to follow this warning could result in personal injury or death.

The unit cabinet must have an uninterrupted or unbroken ground to minimize personal injury if an electrical fault should occur. The ground may consist of electrical wire or metal conduit when installed in accordance with existing electrical codes.

Connect Ground and Power Wires

Connect ground wire to ground connection in control box for safety. Connect power wiring to contactor as shown in Fig. 5.

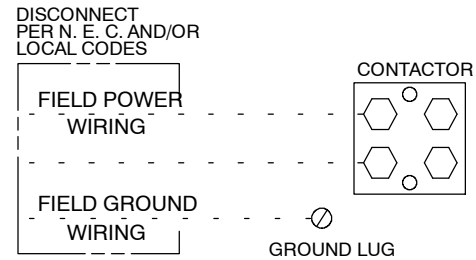

Fig. 5 - Line Power Connections

A91056

Connect Control Wiring

Route low-voltage control wires through control wiring grommet and connect leads to control board.

For 24ANA1 models, connect to Infinity connections ABCD only. Standard non-communicating thermostats are not allowed unless it is an emergency that User Interface is not working properly and new User Interface is not available. For emergency use, connect to standard thermostat connections R, C, Y1 and Y2.

Use No. 18 AWG color-coded, insulated (35°C minimum) wire for all installations.

All wiring must be NEC Class 1 and must be separated from incoming power leads.

Use furnace transformer or fan coil transformer for control power, 24-v/40-va minimum. The outdoor unit requires a minimum of 27va/24 vac control power.

Final Wiring Checks

IMPORTANT: Check factory wiring and field wire connections to ensure terminations are secured properly. Check wire routing to ensure wires are not in contact with tubing, sheet metal, etc.

Compressor Crankcase Heater

Furnish power to crankcase heater a minimum of 24 hr before starting unit. To furnish power to heater only, set thermostat to OFF and close electrical disconnect to outdoor unit.

NOTE: On 24ANA7 models, starting the compressor without a minimum of 12 hours of crankcase heat prior to initial start-up may result in a compressor chattering noise and possible damage to the compressor.

Install Accessories

Refer to the individual instructions packaged with kits or accessories when installing.

24ANA

Make Airflow Selections

Airflow Selection for Variable Speed Furnaces for 24ANA7 models only Using Non-Communicating (non-Infinity) Thermostats

The variable speed furnaces provide blower operation to match the capacities of the compressor during high and low stage cooling operation. The furnace control board allows the installing technician to select the proper airflows for each stage of cooling. Below is a summary of required adjustments. See furnace installation instructions for more details:

1. Turn SW1-5 ON for 400 CFM/ton airflow or OFF for 350 CFM/ton airflow. Factory default is OFF.
2. The A/C DIP switch setting determines airflow during high stage cooling operation. Select the A/C DIP switch setting corresponding to the available airflow shown in the furnace installation instructions that most closely matches the required airflow shown in the air conditioning Product Data for HIGH speed.
3. The CF DIP switch setting determines airflow during low stage cooling operation. Select the CF DIP switch setting corresponding to the available airflow shown in the furnace installation instructions that most closely matches the required airflow shown in the air conditioning Product Data for LOW speed.

If a higher or lower Continuous Fan speed is desired, the Continuous Fan speed can be changed using the fan switch on the thermostat. Refer to the furnace installation instructions for details of how to use this feature.

Airflow Selection for FV4 Fan Coils for 24ANA7 models only Using Non-Communicating (non-Infinity) Thermostats

The FV4 provides high- and low-stage blower operation to match the capacities of compressor at high- and low-stage. To select recommended airflow, refer to the FV4 Installation Instructions. The FV4 utilizes an Easy Select control board that allows the installing technician to select proper airflows. For adjustments to control board and recommended A/C SIZE and CFM ADJUST selections. This fan coil has an adjustable blower off delay factory set at 90 sec. for high- and low-stage blower operation.

For other combinations of equipment consult the Product Data Sheet.

When using communicating (Infinity) control, dipswitch adjustments are not necessary. Airflows are determined by Infinity Control setup. This fan coil is the FE4A or FE5A.

START-UP



CAUTION

UNIT OPERATION AND SAFETY HAZARD

Failure to follow this caution may result in minor personal injury, equipment damage or improper operation.

To prevent compressor damage or personal injury, observe the following:

- Do not overcharge system with refrigerant.
- Do not operate unit in a vacuum or at negative pressure.
- Do not disable low pressure switch
- Dome temperatures may be hot in scroll and bottom temperatures may be hot in recip.



CAUTION

ENVIRONMENTAL HAZARD

Failure to follow this caution may result in environmental damage.

Federal regulations require that you do not vent refrigerant to the atmosphere. Recover during system repair or final unit disposal.

Follow these steps to properly start up the system:

1. After system is evacuated, fully back seat (open) liquid and vapor service valves.
2. Unit is shipped with valve stem(s) front seated (closed) and caps installed. Replace stem caps after system is opened to refrigerant flow (back seated). Replace caps finger-tight and tighten with wrench an additional 1/12 turn.
3. Close electrical disconnects to energize system.
4. Set room thermostat or User Interface at desired temperature. Be sure set point is below indoor ambient temperature and is set low enough to energize desired stage.
5. Set room thermostat or User Interface to COOL and fan control to ON or AUTO mode, as desired. Operate unit for 15 minutes. Check system refrigerant charge.

NOTE: 24ANA7 series only, using non-communicating (non-Infinity) Carrier electronic thermostats are equipped with a 15-minute staging timer. This timer prevents the 2-stage system from operating at high-stage until unit has been operating in low-stage for 15 minutes unless there is at least a $\pm 5^{\circ}\text{F}$ ($\pm 2.78^{\circ}\text{C}$) difference between room temperature and thermostat set point. To force high-stage (after a minimum of 2 minutes in low-stage), adjust the set point at least $\pm 5^{\circ}$ ($\pm 2.78^{\circ}\text{C}$) below room ambient.

6. Set room thermostat to COOL and fan control to AUTO or ON as desired. Wait for appropriate time delay(s). Operate unit for 15 minutes. Check refrigerant charge.

SYSTEM FUNCTIONS AND SEQUENCE OF OPERATION

The outdoor unit control system has special functions. The following is an overview of the 2-stage control functions:

Cooling Operation

The 24ANA7 models utilize either a 2-stage cooling indoor thermostat or an Infinity communicating User Interface. The 24ANA1 models utilize an Infinity communicating User Interface only. With a call for first stage cooling, the outdoor fan and low-stage compressor are energized. If low-stage cannot satisfy cooling demand, high-stage is energized by the second stage of indoor thermostat or User Interface. After second stage is satisfied, the unit returns to low-stage operation until first stage is satisfied or until second stage is required again. When both first stage and second stage cooling are satisfied, the compressor will shut off.

NOTE: On 24ANA7 models, if unit has not operated within the past 12 hrs, or following a unit power-up, upon the next thermostat high- or low-stage demand, unit operates for a minimum of 5 minutes in high-stage.

NOTE: On 24ANA7 models with non-communicating (non-Infinity) systems, with first stage of cooling, (Y1) is powered on; and with second stage of cooling, (Y1 and Y2) are on.

NOTE: When 2-stage unit is operating at low-stage, system vapor (suction) pressure will be higher than a standard single-stage system or high-stage operation.

NOTE: Outdoor fan motor will continue to operate for one minute after compressor shuts off, when outdoor ambient is greater

than or equal to 100°F (37.78°C). This reduces pressure differential for easier starting on the next cycle.

Communication and Status Function Lights

For Infinity Control Only, Green communications (COMM) Light

A green LED (**COMM light**) on the outdoor board (see Fig. 6) indicates successful communication with the other system products. The green LED will remain OFF until communications is established. Once a valid command is received, the green LED will turn ON continuously. If no communication is received within 2 minutes, the LED will be turned OFF until the next valid communication.

Amber Status Light

An amber colored **STATUS light** is used to display the operation mode and fault codes as specified in the troubleshooting section. See Table 6 for codes and definitions.

NOTE: Only one code will be displayed on the outdoor unit control board (the most recent, with the highest priority).

Utility Interface

With Infinity Control

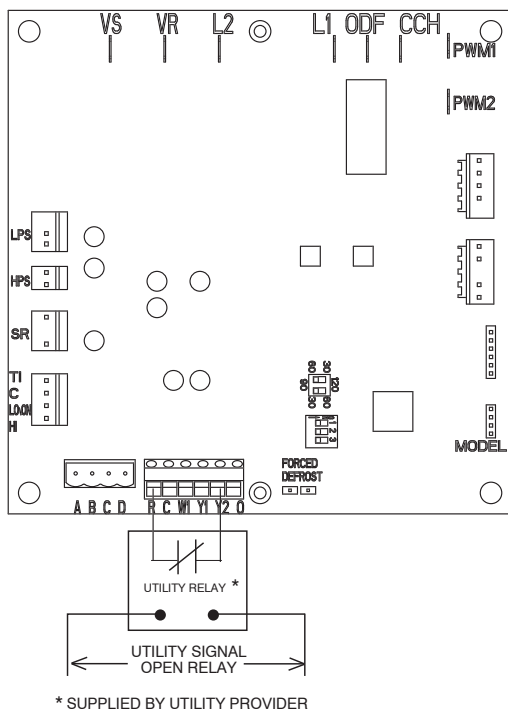

The utility curtailment relay should be wired between R and Y2 connections on the control board for Infinity Communicating Systems only (see Fig. 6.) This input allows a power utility device to interrupt compressor operation during peak load periods. When the utility sends a signal to shut the system down, the User Interface will display, "Curtailment Active".

One Minute Stage Change Time Delay on 24ANA7 Models

When compressor changes stages from high to low or low to high, there is a 1-minute time delay before compressor restarts. The outdoor fan motor remains running.

Compressor Operation on 24ANA7 Models

When the compressor operates in high-stage operation, the motor rotates clockwise. Both the lower and upper pistons are eccentric with the rotating crankshaft and both compress refrigerant.

When the compressor operates in low-stage operation the motor reverses direction (rotates counterclockwise). The lower piston becomes idle and the upper piston compresses refrigerant. **The start and run windings are reversed.**

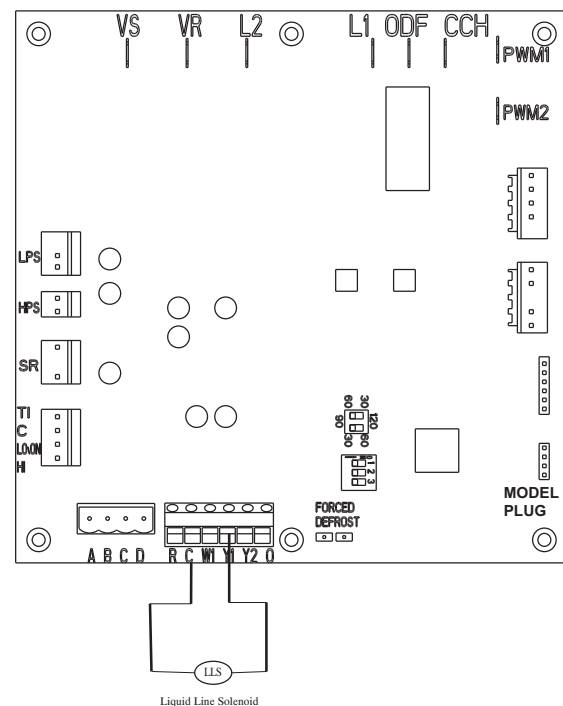

24ANA

Fig. 6 - 2-Stage Control Board

A06526

Compressor Operation on 24ANA1 Models

The basic scroll design has been modified with the addition of an internal unloading mechanism that opens a by-pass port in the first compression pocket, effectively reducing the displacement of the scroll. The opening and closing of the by-pass port is controlled by an internal electrically operated solenoid. The modulated scroll uses a single step of unloading to go from full capacity to approximately 67% capacity.

A single speed, high efficiency motor continues to run while the scroll modulates between the two capacity steps. Modulation is achieved by venting a portion of the gas in the first suction pocket back to the low side of the compressor, thereby reducing the effective displacement of the compressor.

Full capacity is achieved by blocking these vents, thus increasing the displacement to 100%. A DC solenoid in the compressor controlled by a rectified 24 volt AC signal in the external solenoid plug moves the slider ring that covers and uncovers these vents.

The vent covers are arranged in such a manner that the compressor operates at approximately 67% capacity when the solenoid is not energized and 100% capacity when the solenoid is energized. The loading and unloading of the two step scroll is done "on the fly" without shutting off the motor between steps.

NOTE: 67% compressor capacity translates to approximately 75% cooling capacity at the indoor coil.

The compressor will always start unloaded and stay unloaded for five seconds even when the thermostat is calling for high-stage capacity.

Crankcase Heater Operation

The crankcase heater is energized during unit off cycle regardless of OAT temperature on 24ANA7 models.

The crankcase heater is energized during off cycle below 65°F/18.33°C on 24ANA1 models.

Outdoor Fan Motor Operation

The outdoor unit control energizes the outdoor fan any time the compressor is operating except for low-ambient cooling operation. The outdoor fan remains energized if a pressure switch or compressor overload should open. Outdoor fan motor will continue to operate for one minute after the compressor shuts off when the outdoor ambient is greater than or equal to 100°F/37.78°C to allow for easier starting during next cooling cycle.

On 24ANA7 models, the outdoor fan remains energized during the 1-minute compressor staging time delay.

On 24ANA7 models, the outdoor fan motor is a PSC type. A fan relay on the control board turns the fan off and on by opening and closing a high voltage circuit to the motor. It does not change speeds between low- and high-stage operation.

On 24ANA1 models, the outdoor fan is an ECM type. The motor control is continuously powered with high voltage. The motor speed is determined by electrical pulses provided by the PWM outputs on the control board. The ECM motor RPM adjusts to outdoor conditions as described in Table 3. The PWM output can be measured with a volt meter set to DC volts.

Table 3 – Outdoor Fan Motor PWM Above 55°F/12.78°C Outdoor Temp (DC volts, Tolerance +/- 2%)

MODEL	LOW-STAGE (OAT≤104°F/40°C)	HIGH-STAGE (OAT≤104°F/40°C)	LOW- & HIGH-STAGE (OAT>104°F/40°C)
24ANA124	9.57	10.88	11.90
24ANA136	9.06	10.23	11.90
24ANA148	9.91	11.04	11.90
24ANA160	10.83	11.70	11.90

NOTE:

For 24ANA1 models in low-ambient cooling, the PWM output for both high- and low-stage equals the value for low-stage operation below 104°F/40°C.

In low ambient cooling (below 55°F/12.78°C) on 24ANA7 and 24ANA1 models, the control board cycles the fan off and on.

Time Delays

The unit time delays include:

- Five minute time delay to start cooling or heating operation when there is a call from the thermostat or user interface. To bypass this feature, momentarily short and release Forced Defrost pins.
- Five minute compressor re-cycle delay on return from a brown-out condition.
- Two minute time delay to return to standby operation from last valid communication (with Infinity only).
- One minute time delay of outdoor fan at termination of cooling mode when outdoor ambient is greater than or equal to 100°F/37.78°C.
- On 24ANA7 models there is a 1 minute time delay between staging from low to high and from high to low capacity. On 24ANA1 models there is no delay; the compressor will change from low to high and from high to low capacity on the fly to meet the demand.

Low Ambient Cooling

If this unit will be required to operate below 55°F/12.78°C outdoor temperature, provisions must be made for low ambient operation.

Infinity Controlled low ambient cooling:

This unit is capable of low ambient cooling down to 0°F/-17.78°C without a kit ONLY when using Infinity control. A low ambient kit is not required, and the outdoor fan motor does not need to be replaced for Infinity controlled low ambient operation. The Infinity Control provides an automatic evaporator coil freeze protection algorithm that eliminates the need for an evaporator freeze thermostat. Low ambient cooling must be enabled in the User Interface set up. Fan may not begin to cycle until about 40°F/4.4°C OAT. Fan will cycle based on coil and outdoor air temperature.

Infinity controlled low ambient mode operates as follows:

- Fan is OFF when outdoor coil temp is < (outdoor air temperature + 3 °F/1.67°C) or outdoor fan has been ON for 30 minutes. (Fan is turned off to allow refrigerant system to stabilize.)
- Fan is ON when outdoor coil temp > (outdoor air temperature + 25°F/13.89°C) or outdoor coil temp > 80°F/26.67°C or if outdoor fan has been OFF for 30 minutes. (Fan is turned on to allow refrigerant system to stabilize.)
- Low pressure switch is ignored for first 3 minutes during low ambient start up. After 3 minutes, if LPS trips, then outdoor fan motor is turned off for 10 minutes, with the compressor running. If LPS closes within 10 minutes then cooling continues with the outdoor fan cycling per the coil temperature routine listed above for the remainder of the cooling cycle. If the LPS does not close within 10 minutes, then the normal LPS trip response (shut down cooling operation and generate LPS trip error) will occur.

For 24ANA1 models, the PWM output for both high- and low-stage equals the value for low-stage operation below 104°F/40°C.

Check Charge

All 24ANA units must be charged in high stage only.

Factory charge amount and desired subcooling are shown on unit rating plate. Charging method is shown on information plate inside unit. To properly check or adjust charge, conditions must be favorable for subcooling charging. Favorable conditions exist when the outdoor temperature is between 70°F and 100°F (21.11°C and 37.78°C), and the indoor temperature is between 70°F and 80°F (21.11°C and 26.67°C). Follow the procedure below:

Unit is factory charged for 15ft (4.57 m) of lineset. Adjust charge by adding or removing 0.6 oz/ft of 3/8 liquid line above or below 15ft (4.57 m) respectively.

For standard refrigerant line lengths (80 ft/24.38 m or less), allow system to operate in cooling mode at least 15 minutes. If conditions are favorable, check system charge by subcooling method. If any adjustment is necessary, adjust charge slowly and allow system to operate for 15 minutes to stabilize before declaring a properly charged system.

If the indoor temperature is above 80°F (26.67°C), and the outdoor temperature is in the favorable range, adjust system charge by weight based on line length and allow the indoor temperature to drop to 80°F (26.67°C) before attempting to check system charge by subcooling method as described above.

If the indoor temperature is below 70°F (21.11°C), or the outdoor temperature is not in the favorable range, adjust charge for line set length above or below 15ft (4.57 m) only. Charge level should then be appropriate for the system to achieve rated capacity. The charge level could then be checked at another time when the both indoor and outdoor temperatures are in a more favorable range.

NOTE: If line length is beyond 80 ft (24.38 m) or greater than 20 ft (6.10 m) vertical separation, See Long Line Guideline for special charging requirements.

TROUBLESHOOTING

Systems Communication Failure

If communication with the Infinity Control is lost with the user interface, the control will flash the appropriate fault code. (See Table 6) Check the wiring to the User Interface, indoor and outdoor units.

Model Plug

Each control board contains a model plug. The correct model plug must be installed for or the system to operate properly. (See Table 4.)

The model plug is used to identify the type and size of unit to the control. On 24ANA7 models, the model plug is also used to determine the start sequence timing for each individual model.

On new units, the model and serial numbers are input into the board's memory at the factory. If a model plug is lost or missing at initial installation, the unit will operate according to the information input at the factory and the appropriate error code will flash temporarily. An RCD replacement board contains no model and serial information. If the factory control board fails, the model plug must be transferred from the original board to the replacement board for the unit to operate.

NOTE: The model plug takes priority over factory model information input at the factory. If the model plug is removed after initial power up, the unit will operate according to the last valid model plug installed, and flash the appropriate fault code temporarily.

Table 4 – Model Plug Information

MODEL NUMBER	MODEL PLUG NUMBER	PIN RESISTANCE (K-ohms)	
		Pins 1–4	Pins 2–3
24ANA724	HK70EZ001	5.1	11
24ANA736	HK70EZ003	5.1	24
24ANA748	HK70EZ005	5.1	39
24ANA760	HK70EZ007	5.1	62
24ANA124	HK70EZ009	5.1	91
24ANA136	HK70EZ011	5.1	150
24ANA148	HK70EZ013	5.1	220
24ANA160	HK70EZ015	5.1	360

Pressure Switch Protection

The outdoor unit is equipped with high- and low-pressure switches. If the control senses the opening of a high or low pressure switch, it will respond as follows:

1. De-energize the appropriate compressor contactor,
2. Keep the outdoor fan operating for 15 minutes,
3. Display the appropriate fault code (see Table 6).
4. After a 15 minute delay, if there is still a call for cooling and the LPS or HPS is reset, the appropriate compressor contactor is energized.
5. If LPS or HPS has not closed after a 15 minute delay, the outdoor fan is turned off. If the open switch closes anytime after the 15-minute delay, then resume operation with a call for cooling.
6. If LPS or HPS trips 3 consecutive cycles, the unit operation is locked out for 4 hours.
7. In the event of a high pressure switch trip or high pressure lockout, check the refrigerant charge outdoor fan operation and outdoor coil for airflow restrictions.
8. In the event of a low pressure switch trip or low pressure lockout, check the refrigerant charge and indoor airflow.

Control Fault

If the outdoor unit control board has failed, the control will flash the appropriate fault code. (See Table 6) The control board should be replaced.

Brown Out Protection

If the line voltage is less than 187v for at least 4 seconds, the appropriate compressor contactor and fan relay are de-energized. Compressor and fan operation are not allowed until voltage is a minimum of 190v. The control will flash the appropriate fault code (see Table 6).

230V Line (Power Disconnect) Detection

If there is no 230v at the compressor contactor(s) when the indoor unit is powered and cooling demand exists, the appropriate error code is displayed (see Table 6). Verify that the disconnect is closed and 230v wiring is connected to the unit.

Compressor Voltage Sensing

The control board input terminals labeled VS, VR and L2 on 24ANA7 models and VS and L2 on 24ANA1 models (see Fig. 6) are used to detect compressor voltage status, and alert the user of potential problems. The control continuously monitors the high voltage on the run capacitor of the compressor motor. Voltage should be present any time the compressor contactor is energized, and voltage should not be present when the contactor is de-energized.

Contactor Shorted Detection

If there is compressor voltage sensed when there is no demand for compressor operation, the contactor may be stuck closed or there is a wiring error. The control will flash the appropriate fault code.

24ANA7 Models, Compressor Thermal Cutout

The control senses the compressor voltage at VR and VS. When starting or running, a phase difference of the voltages on the inputs will indicate the thermal protector is closed. If the phase difference is 5 degrees or less for 10 seconds, the internal protector is open. The control de-energizes the appropriate compressor contactor for 15 minutes, but continues to operate the outdoor fan. The control Status LED will flash the appropriate code shown in Table 6. After 15 minutes, with a call for low- or high-stage cooling, the appropriate compressor contactor is energized. If the thermal protector has not re-set, the outdoor fan is turned off. If the call for cooling or heating continues, the control will energize the compressor contactor every 15 minutes. If the thermal protector closes, (at the next 15 minute interval check), the unit will resume operation.

If the thermal cutout trips for three consecutive cycles, then unit operation is locked out for 4 hours and the appropriate fault code is displayed.

24ANA1 Models, Compressor Thermal Cutout

If the control senses the compressor voltage after start-up, and is then absent for 10 consecutive seconds while cooling demand exists, the thermal protector is open. The control de-energizes the compressor contactor for 15 minutes, but continues to operate the outdoor fan. The control Status LED will flash the appropriate code shown in Table 6. After 15 minutes, with a call for low- or high-stage cooling, the compressor contactor is energized. If the thermal protector has not re-set, the outdoor fan is turned off. If the call for cooling continues, the control will energize the compressor contactor every 15 minutes. If the thermal protector closes, (at the next 15 minute interval check), the unit will resume operation.

If the thermal cutout trips for three consecutive cycles, then unit operation is locked out for 4 hours and the appropriate fault code is displayed.

Low or High Contactor Open (24ANA7 models) / No 230V at Compressor (24ANA1 models)

If the compressor voltage is not sensed when the compressor should be starting, the appropriate contactor may be stuck open or there is a wiring error. The control will flash the appropriate fault code. Check the contactor and control box wiring.

24ANA7 Models Only, Compressor Start Detection

In low-stage, if the specified start voltage at VR terminal is not achieved, the start relay is de-energized after 1 second and the control will flash the appropriate fault code.

In high-stage, if the specified start voltage at VS terminal is not achieved, the start relay is de-energized after 1 second and the control will flash the appropriate fault code.

If the specified start voltage is not achieved for 3 consecutive low-stage starts, low-stage operation is locked out for 30 minutes. If the specified start voltage is not achieved for 3 consecutive high-stage starts, high-stage operation is locked out for 30 minutes. The control will flash the appropriate fault code.

Troubleshooting 24ANA7 units for proper switching between low- & high-stages

Check the suction and liquid pressures at the service valves. Suction pressure should be reduced by 5-10% when switching from low to high capacity. There should be a 10-20% increase in liquid pressure when switching from low to high capacity. Compressor current should increase 100-250% when switching from low to high-stage.

Troubleshooting 24ANA1 units for proper switching between low- & high-stages

Check the suction pressures at the service valves. Suction pressure should be reduced by 3-10% when switching from low to high capacity.

NOTE: The liquid pressures are very similar between low- and high-stage operation, so liquid pressure should not be used for troubleshooting.

Compressor current should increase 20-45% when switching from low- to high-stage. The compressor solenoid when energized in high-stage, should measure 24vac.

When the compressor is operating in low-stage the 24v DC compressor solenoid coil is de-energized. When the compressor is operating in high-stage, the 24v DC solenoid coil is energized. The solenoid plug harness that is connected to the compressor has an internal rectifier that converts the 24v DC signal to 24v AC. **DO NOT INSTALL A PLUG WITHOUT AN INTERNAL RECTIFIER.**

Unloader Test Procedure

The unloader is the compressor internal mechanism, controlled by the DC solenoid, that modulates between high- and low-stage. If it is suspected that the unloader is not working, the following methods may be used to verify operation.

1. Operate the system and measure compressor amperage. Cycle the unloader on and off at 30 second plus intervals at the UI (from low- to high-stage and back to low-stage).

Wait 5 seconds after staging to high before taking a reading. The compressor amperage should go up or down at least 20 percent.

2. If step one does not give the expected results, remove the solenoid plug from the compressor and with the unit running and the UI calling for high-stage, test the voltage output at the plug with a DC voltmeter. The reading should be 24 volts DC.
3. If the correct DC voltage is at the control circuit molded plug, measure the compressor unloader coil resistance. The resistance should be 32 to 60 ohms depending on compressor temperature. If the coil resistance is infinity, much lower than 32 ohms, or is grounded, the compressor must be replaced.

MAJOR COMPONENTS

2-Stage Control

The 2-stage control board controls the following functions:

- Low- and high-stage compressor contactor operation
- Outdoor fan motor operation
- Low ambient cooling
- Crankcase heater operation
- Compressor external protection
- Pressure switch monitoring
- Time delays
- On 24ANA7 models, start relay and capacitor

Field Connections

On 24ANA7 models with non-communicating (non-Infinity) system, the 2-stage control receives 24vac low-voltage control system inputs through the R, C, Y1, and Y2 connections located at the bottom of the control board (see Fig. 6). The 24ANA7 can be controlled using a standard 2-stage thermostat or Infinity User Interface.

All 24ANA1 models are part of a complete Infinity communicating system and use only the ABCD connections on the circuit board. The 24ANA1 must be controlled using an Infinity User Interface for proper equipment staging and operation

2-Stage Compressor

The 2-stage compressor contains motor windings that provide 2-pole (3500 RPM) operation. Refer to Table 5 for correct winding resistance.

Compressor Internal Relief

The compressor is protected by an internal pressure relief (IPR) which relieves discharge gas into compressor shell when differential between suction and discharge pressures exceeds 500 - 550 psi on 24ANA7 models and 550 - 625 psi on 24ANA1 models.. The compressor is also protected by an internal overload attached to motor windings.

Compressor Control Contactors

The contactor(s) have a 24 volt coil. The electronic control board controls the operation of the appropriate contactors.

**Table 5 – 2-Stage Compressor
(Winding Resistance at 70°F ± 20° / 21.11°C ± 11.11°C)**

Winding	24ANA724	24ANA736	24ANA748	24ANA760
Start (S-C)	2.74	1.98	1.55	0.74
Run (R-C)	0.80	0.75	0.48	0.36

Winding	24ANA124	24ANA136	24ANA148	24ANA160
Start (S-C)	1.40	1.29	1.52	0.60
Run (R-C)	1.32	0.89	0.64	0.49

TEMPERATURE THERMISTORS

Thermistors are electronic devices which sense temperature. As the temperature increases, the resistance decreases. Thermistors are used to sense outdoor ambient (OAT) and coil temperature (OCT). Refer to Fig. 7 for resistance values versus temperature.

If the outdoor ambient or coil thermistor should fail, the control will flash the appropriate fault code (see Table 6.)

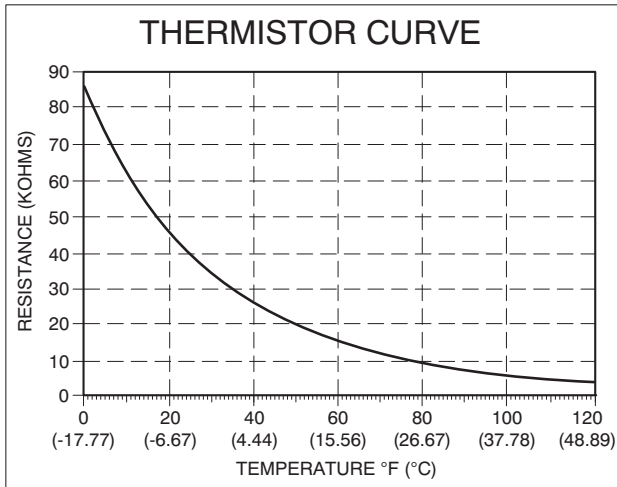

A08054

Fig. 7 - Resistance Values Versus Temperature

OAT Thermistor must be locked in place with spherical nib end facing towards the front of the control box

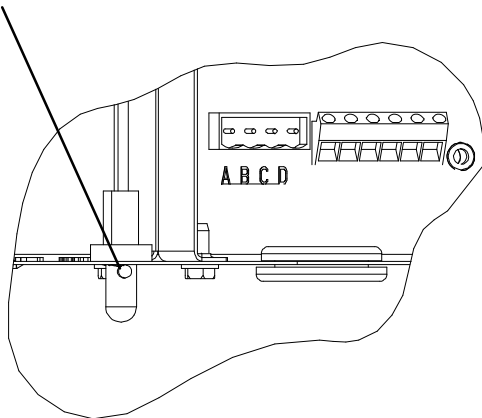

Fig. 8 - Outdoor Air Thermistor (OAT) Attachment

FINAL CHECKS

IMPORTANT: Before leaving job, be sure to do the following:

1. Ensure that all wiring is routed away from tubing and sheet metal edges to prevent rub-through or wire pinching.
2. Ensure that all wiring and tubing is secure in unit before adding panels and covers. Securely fasten all panels and covers.
3. Tighten service valve stem caps to 1/12-turn past finger tight.
4. Leave Users Manual with owner. Explain system operation and periodic maintenance requirements outlined in manual.
5. Fill out Dealer Installation Checklist and place in customer file.

IMPORTANT: Outdoor air thermistor and coil thermistor are factory mounted in the final locations. Check to insure thermistors are mounted properly per Fig. 8 and Fig. 9.

Thermistor Sensor Comparison

The control continuously monitors and compares the outdoor air temperature sensor and outdoor coil temperature sensor to ensure proper operating conditions. The comparison is:

- If the outdoor air sensor indicates $\geq 10^{\circ}\text{F}/5.56^{\circ}\text{C}$ warmer than the coil sensor (or) the outdoor air sensor indicates $\geq 20^{\circ}\text{F}/11.11^{\circ}\text{C}$ cooler than the coil sensor, the sensors are out of range.

If the sensors are out of range, the control will flash the appropriate fault code as shown in Table 6.

The thermistor comparison is not performed during low ambient cooling or defrost operation.

Failed Thermistor Default Operation

Factory defaults have been provided in the event of failure of outdoor air thermistor and/or coil thermistor.

If the OAT sensor should fail, low ambient cooling will not be allowed and the one-minute outdoor fan off delay will not occur.

If the OCT sensor should fail, low ambient cooling will not be allowed.

OCT Thermistor must be secured tight on the liquid tube.

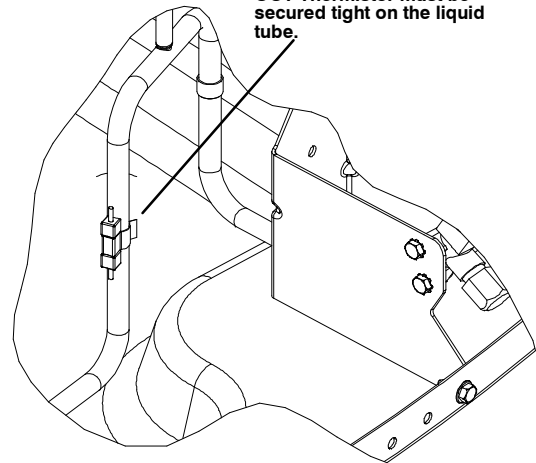

Fig. 9 - Outdoor Coil Thermistor (OCT) Attachment

CARE AND MAINTENANCE

For continuing high performance and to minimize possible equipment failure, periodic maintenance must be performed on this equipment.

Frequency of maintenance may vary depending upon geographic areas, such as coastal applications. See Users Manual for information.

Status Codes

Table 6 shows the status codes flashed by the amber status light. Most system problems can be diagnosed by reading the status code as flashed by the amber status light on the control board.

The codes are flashed by a series of short and long flashes of the status light. The short flashes indicate the first digit in the status code, followed by long flashes indicating the second digit of the error code. The short flash is 0.25 seconds ON and the long flash is 1.0 second ON. Time between flashes is 0.25 seconds. Time

between short flash and first long flash is 1.0 second. Time between code repeating is 2.5 seconds with LED OFF.

Count the number of short and long flashes to determine the appropriate flash code. Table 6 gives possible causes and actions related to each error.

EXAMPLE:

3 short flashes followed by 2 long flashes indicates a 32 code. Table 6 shows this to be low pressure switch open.

Table 6 – TROUBLESHOOTING

OPERATION	FAULT	AMBER LED FLASH CODE	POSSIBLE CAUSE AND ACTION
Standby – no call for unit operation	None	On solid, no flash	Normal operation
Emergency Mode – Model 24ANA1 only	Standard Thermostat Control (24ANA1 only)	Rapid, continuous flashing	Unit being controlled by standard thermostat inputs instead of Infinity Control. Only high-stage operation is available. This operating mode should be used in emergency situations only.
low-stage Cool/Heat Operation	None	1, pause	Normal operation
high-stage Cool/Heat Operation	None	2, pause	Normal operation
	System Communications Failure	16	Communication with user interface lost. Check wiring to User Interface, indoor and outdoor units
	Invalid Model Plug	25	Control does not detect a model plug or detects an invalid model plug. Unit will not operate without correct model plug.
	High Pressure Switch Open	31*	High-pressure switch trip. Check refrigerant charge, outdoor fan operation and coils for airflow restrictions.
	Low Pressure Switch Open	32*	Low pressure switch trip. Check refrigerant charge and indoor air flow
	Control Fault	45	Outdoor unit control board has failed. Control board needs to be replaced.
	Brown Out (230 v)	46	Line voltage < 187v for at least 4 seconds. Compressor and fan operation not allowed until voltage \geq 190v. Verify line voltage.
	No 230v at Unit	47	There is no 230v at the contactor when indoor unit is powered and cooling/heating demand exists. Verify the disconnect is closed and 230v wiring is connected to the unit.
	Outdoor Air Temp Sensor Fault	53	Outdoor air sensor not reading or out of range. Ohm out sensor and check wiring.
	Outdoor Coil Sensor Fault	55	Coil sensor not reading or out of range. Ohm out sensor and check wiring.
	Thermistors out of range	56	Improper relationship between coil sensor and outdoor air sensor. Ohm out sensors and check wiring.
	low-stage Thermal Cutout	71*	Compressor operation detected then disappears while low-stage demand exists. Possible causes are internal compressor overload trip or start relay and capacitor held in circuit too long (if installed)
	high-stage Thermal Cutout	72*	Compressor operation detected then disappears while high-stage demand exists. Possible causes are internal compressor overload trip or start relay and capacitor held in circuit too long (if installed)
	Contactor Shorted	73	Compressor voltage sensed when no demand for compressor operation exists. Contactor may be stuck closed or there is a wiring error.
	No 230V at Compressor (24ANA1 Only)	74	Compressor voltage not sensed when compressor should be starting. Contactor may be stuck open or there is a wiring error.
	low-stage Did Not Start (24ANA7 Only)	75	Specified start voltage at VR terminal was not achieved in low-stage. Start relay was de-energized after 1 second.
	low-stage Did Not Start 3 times (24ANA7 Only)	76	For 3 consecutive low-stage starts, the specified start voltage at VR terminal was not achieved & start relay was de-energized. low-stage locked out for 30 minutes.
	high-stage Did Not Start (24ANA7 Only)	77	Specified start voltage at VS terminal was not achieved in high-stage. Start relay was de-energized after 1 second.
	high-stage Did Not Start 3 times (24ANA7 Only)	78	For 3 consecutive high-stage starts, the specified start voltage at VS terminal was not achieved & start relay was de-energized. high-stage locked out for 30 minutes.
	low-stage Thermal Lockout	81	Thermal cutout occurs in three consecutive low/high-stage cycles. low-stage locked out for 4 hours or until 24v power recycled.
	high-stage Thermal Lockout	82	Thermal cutout occurs in three consecutive high/low-stage cycles. high-stage locked out for 4 hours or until 24v power recycled.
	Low Pressure Lockout	83	Low pressure switch trip has occurred during 3 consecutive cycles. Unit operation locked out for 4 hours or until 24v power recycled.
	High Pressure Lockout	84	High pressure switch trip has occurred during 3 consecutive cycles. Unit operation locked out for 4 hours or until 24v power recycled.
	Low Contactor Open (24ANA7 Only)	85	Compressor voltage not sensed when compressor should be starting. low-stage contactor may be stuck open or there is a wiring error.
	High Contactor Open (24ANA7 Only)	87	Compressor voltage not sensed when compressor should be starting. high-stage contactor may be stuck open or there is a wiring error.

* Sequence: Compressor contactor is de-energized and outdoor fan is energized for up to 15 minutes. If demand still exists, control will energize compressor contactor after 15 minute delay. If fault is cleared, unit will resume operation. If fault still exists, fan shuts off, and error code continues to flash. Control will attempt re-start every 15 minutes. Cycling low voltage defeats the 15 minute delay.

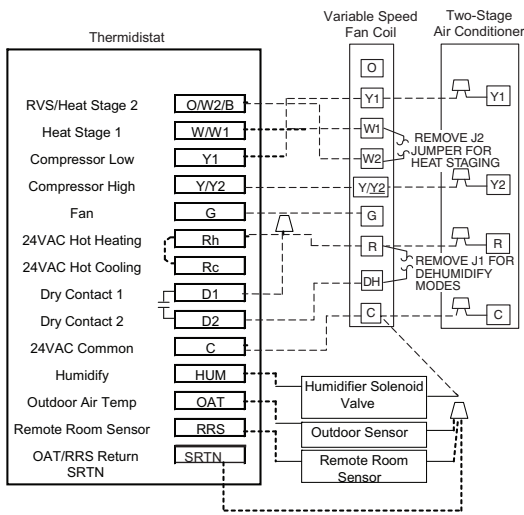

A08060

Edge Thermostat Models TP-PRH-01 & TP-NRH-01
w/ Fan Coil & 2-Stage Air Conditioner

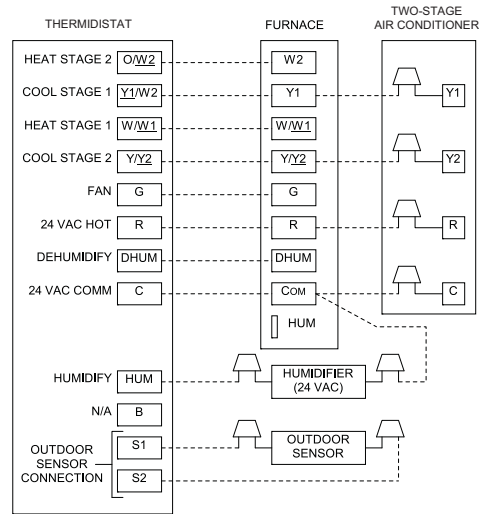

A08056

Thermostat Model TSTATCCPRH01-B
w/ VS Furnace & 2-Stage Air Conditioner

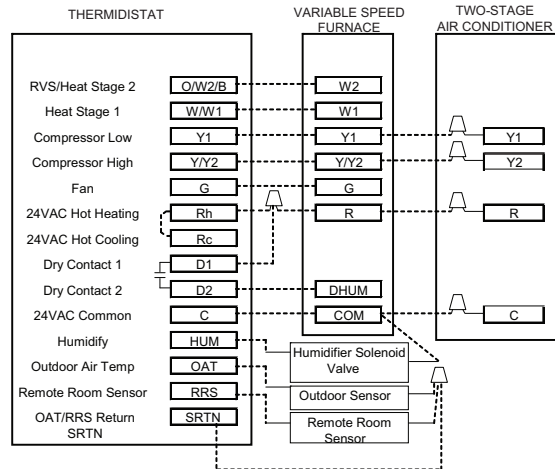

A08057

Edge Thermostat Models TP-PRH-01 & TP-NRH-01
w/ Furnace & 2-Stage Air Conditioner

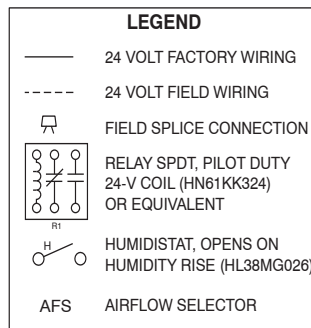

A02005

Fig. 10 - Thermostat Wiring with 2-Stage Puron refrigerant Air Conditioner
Applies to 24ANA7 Models Only

24ANA

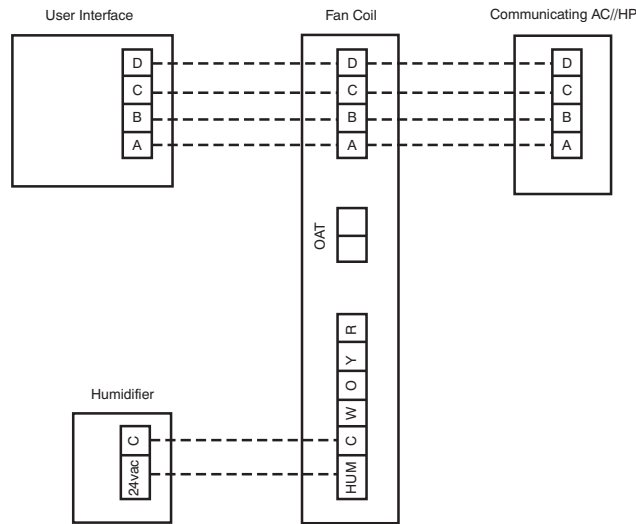

A03076

Fig. 11 - Infinity Furnace or Fan Coil Wiring with Communicating 2-stage AC / HP

PURON® (R-410A) REFRIGERANT QUICK REFERENCE GUIDE

- Puron refrigerant operates at 50-70 percent higher pressures than R-22. Be sure that servicing equipment and replacement components are designed to operate with Puron refrigerant
- Puron refrigerant cylinders are rose colored.
- Recovery cylinder service pressure rating must be 400 psig, DOT 4BA400 or DOT BW400.
- Puron refrigerant systems should be charged with liquid refrigerant. Use a commercial type metering device in the manifold hose when charging into suction line with compressor operating
- Manifold sets should be 700 psig high side and 180 psig low side with 550 psig low-side retard.
- Use hoses with 700 psig service pressure rating.
- Leak detectors should be designed to detect HFC refrigerant.
- Puron refrigerant, as with other HFCs, is only compatible with POE oils.
- Vacuum pumps will not remove moisture from oil.
- Do not use liquid-line filter driers with rated working pressures less than 600 psig.
- Do not leave Puron suction line filter driers in line longer than 72 hours.
- Do not install a suction-line filter drier in liquid line.
- POE oils absorb moisture rapidly. Do not expose oil to atmosphere.
- POE oils may cause damage to certain plastics and roofing materials.
- Wrap all filter driers and service valves with wet cloth when brazing.
- A factory approved liquid-line filter drier is required on every unit.
- Do NOT use an R-22 TXV.
- If indoor unit is equipped with an R-22 TXV or piston metering device, it must be changed to a hard shutoff balanced port Puron TXV.
- Never open system to atmosphere while it is under a vacuum.
- When system must be opened for service, recover refrigerant, evacuate then break vacuum with dry nitrogen and replace filter driers. Evacuate to 500 microns prior to recharging.
- Do not vent Puron refrigerant into the atmosphere.
- Do not use capillary tube coils.
- Observe all **warnings**, **cautions**, and **bold** text.
- All indoor coils must be installed with a hard shutoff balanced port Puron TXV metering device.