

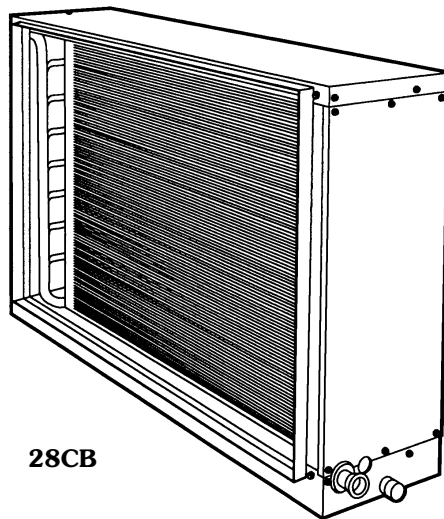

Product Data

28CB, 28LA Direct-Expansion Evaporator Coils

7¹/₂ and 10 Nominal Tons Cooling



28CB

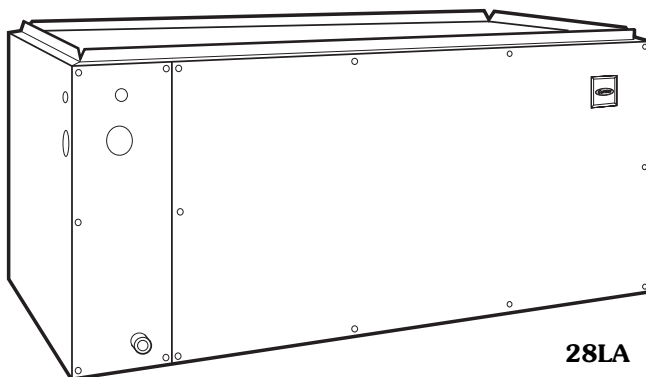

28LA

Direct-expansion evaporator coils easily accommodate upflow or horizontal light-commercial applications

Features/Benefits

28LA and 28CB direct-expansion evaporator coils matched with 38ARZ units provide efficient cooling for furnace systems

If your light commercial application calls for direct-expansion evaporator coils in the popular 7¹/₂ to 10 ton nominal capacity range, consider Carrier's performance-proven 28LA and 28CB coils. Matched for use with Carrier's 38ARZ007 and 38ARZ008 condensing units, these versatile coils can be used in either new construction or renovation projects.

Whether the application is with a duct furnace, or an upflow or horizontal furnace, 28LA and 28CB coils offer cost-saving heat transfer performance. Coil enclosures are fully insulated to maximize cooling power and optimize operating economy.

The 28LA upflow coil offers a variety of piping possibilities through the front access panel or at either end of the unit, whichever best suits the conditions at the jobsite. The 28LA coil includes a factory-matched and factory-installed thermostatic expansion valve for R-22.

The 28CB horizontal coil matches readily with horizontal and duct furnaces, or can be applied within the duct.



System ratings using the 28LA and 28CB coils are ARI certified, and have been tabulated and selected for combinations that represent reliable, balanced cooling systems that are easy to install. No expensive field fabrication time or cost is necessary: after

furnace-to-coil surfaces are gasketed, field piping can be quickly connected.

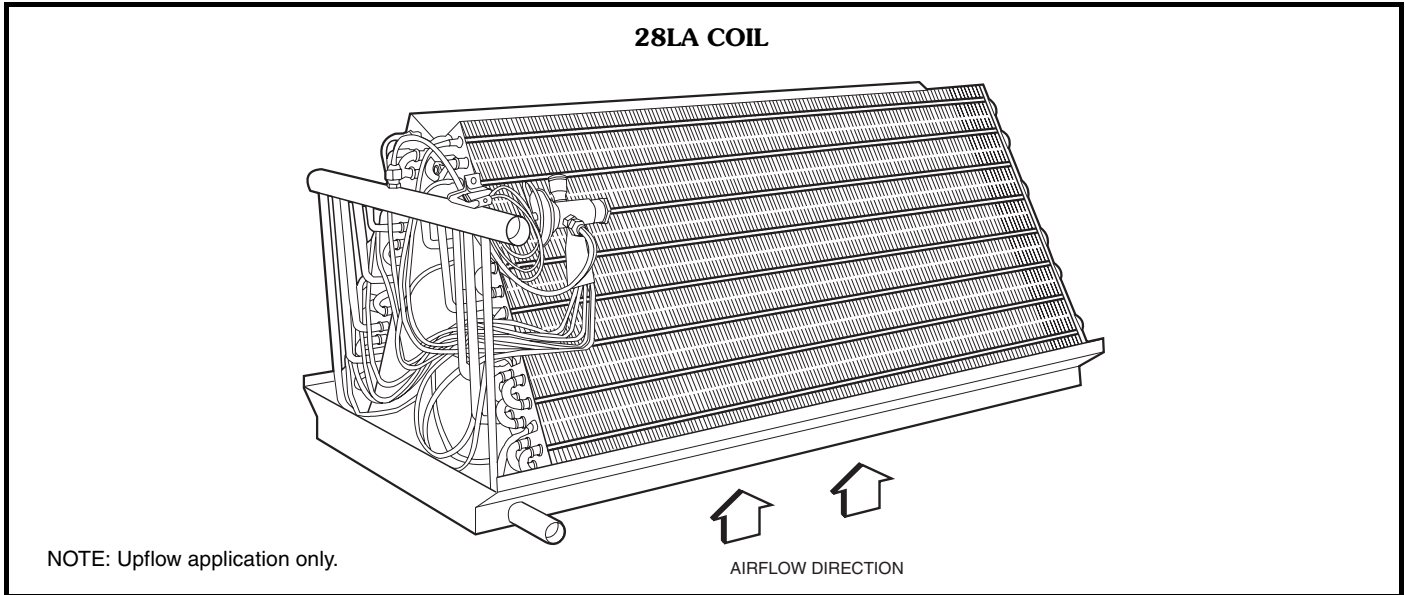
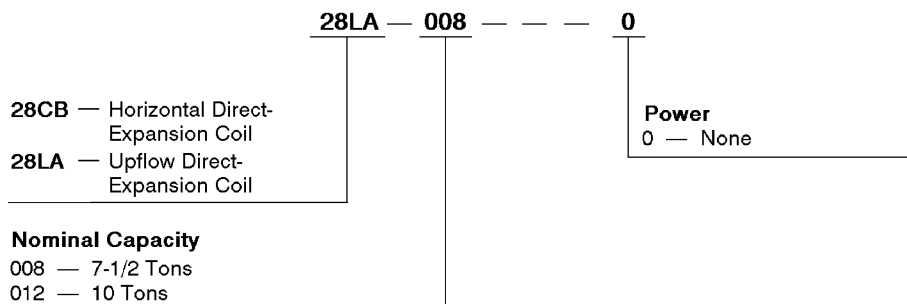

Table of contents

	Page
Features/Benefits	1,2
Model Number Nomenclature	2
ARI Capacity Ratings	3
Physical Data	3
Dimensions	4
Selection Procedure	5
Performance Data	5
Typical Piping and Wiring	6
Application Data	7
Guide Specifications	7

Model number nomenclature



ARI* capacity ratings



COIL	CONDENSING UNIT	SYSTEM†	
		Net Capacity (Btuh)	EER
28LA008	38ARZ007	66,000	10.3
28LA012	38ARZ008	88,000	10.3
28CB012	38ARZ008	88,000	10.3

LEGEND

EER — Energy Efficiency Ratio (Btuh/watt)

*Air Conditioning and Refrigeration Institute.

†Rated in accordance with ARI Standard 210/240-89.



Physical data

UNIT	28LA		28CB	
	008	012	008	012
OPERATING WT (lb)	100	142	90	125
REFRIGERANT	R-22			
DISTRIBUTION NOZZLE SIZE	G8*	E10*	J5†	G8†
FACE AREA (SQ FT)	7.44	9.79	7.37	10.35
ROWS...FINS/IN.	3...12		3...11	
NUMBER OF CIRCUITS	12	12	9	10
AIR QUANTITY (Cfm) Nominal Range	3000 2250-3375**	4000 3000-4500**	3000 2250-3375**	4000 3000-4650**

*Refrigerant control thermostatic expansion valve (TXV) is factory-installed.

†Refrigerant control thermostatic expansion valve (TXV) is field-supplied.

**Air quantities in excess of values shown may result in moisture blow-off.

Dimensions

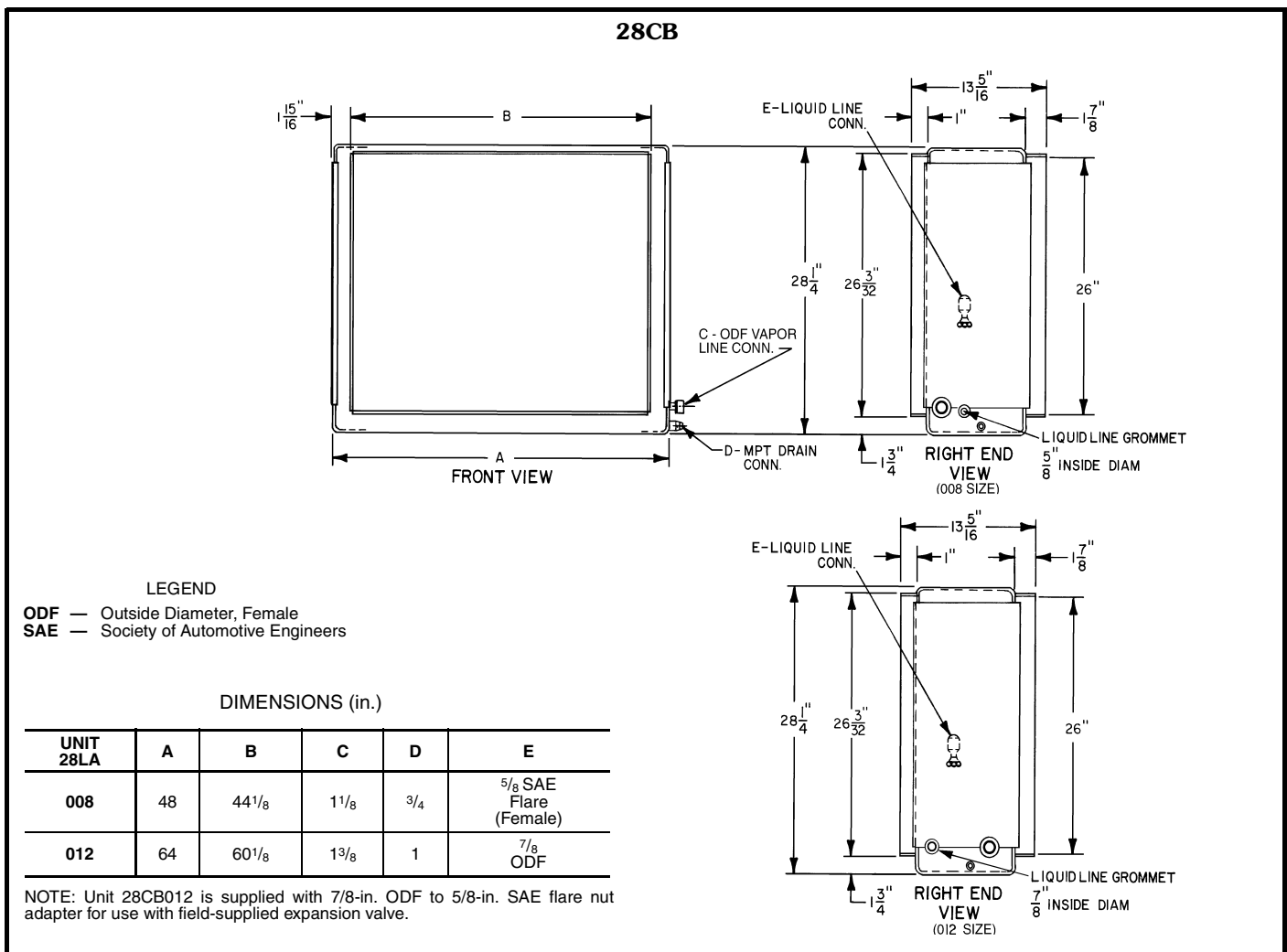
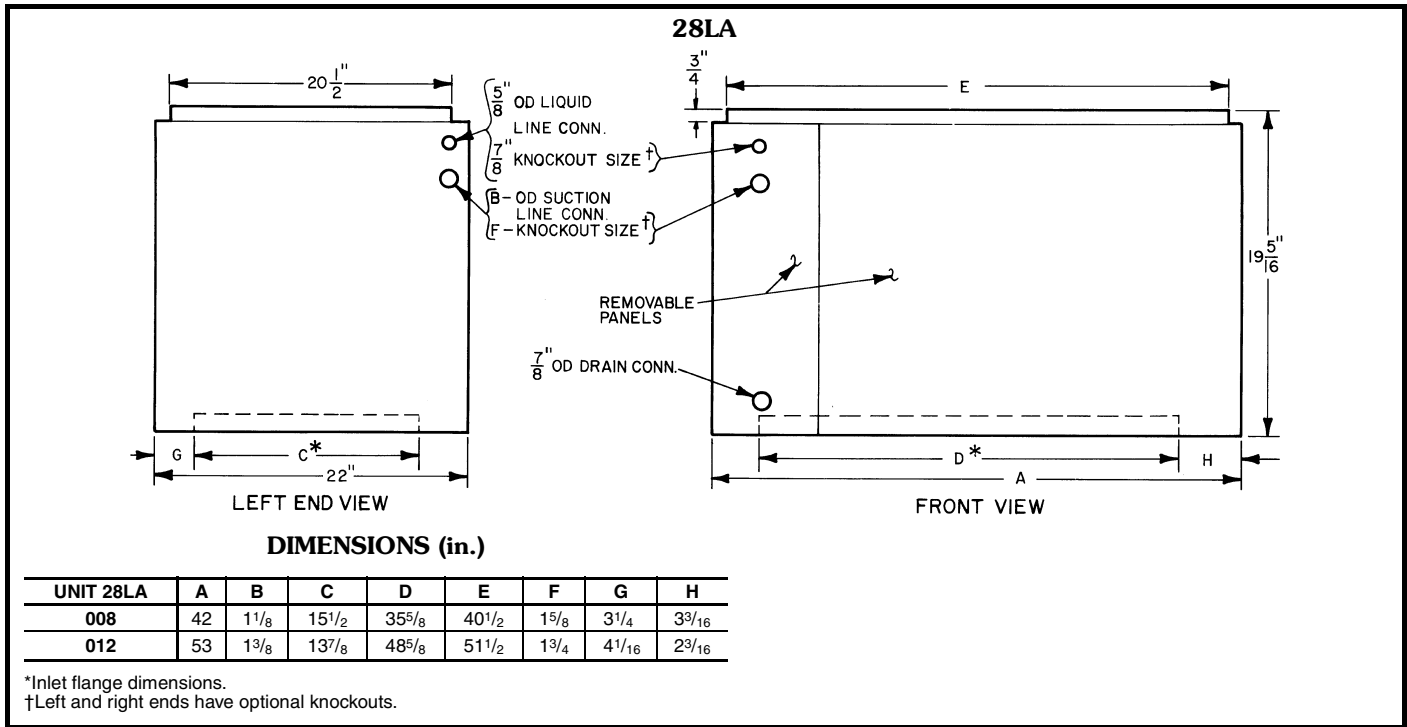

Selection procedure



Detailed ratings for 28LA and 28CB coils matched with 38ARZ condensing units shown in the ARI Capacity Ratings table (page 3) are available in the 38ARZ Product Data catalog. The same combinations and ratings are also available in Carrier's Electronic Catalog (E-CAT) software program.

To match 28LA and 28CB coils with condensing units not listed in the ARI Capacity Ratings table, please use E-CAT selection software, or contact Commercial Split System Application Engineering for assistance.

Performance data

COOLING CAPACITIES

UNIT	CFM BF		COIL REFRIGERANT TEMPERATURE (F)														
			30			35			40			45			50		
			Evaporator Air Entering Wet-Bulb Temp (F)														
			72	67	62	72	67	62	72	67	62	72	67	62	72	67	62
28LA008	2250	TC	—	121	98	135	105	82.5	117.5	89	66	97.5	71	48	77	52	—
	.161	SC	—	73	77	61	66	70	54	59	62	49	51	48	40	43	—
	3000	TC	—	—	115	—	126	98	136	106	80	115	84	60	91	60	—
28LA012	.201	SC	—	—	94	—	79	85	65	71	76	57	63	60	48	53	—
	3375	TC	—	—	123	—	134	104	—	113	84	122	90	67.5	98	65	—
	.217	SC	—	—	101	—	85	92	—	77	83	61	68	67.5	52	58	—
28CB008	3500	TC	—	—	147	—	158	120	173	130	94	141	100	66	108	75	—
	.169	SC	—	—	116	—	100	104	82	87	91	70	75	66	57	62	—
	4000	TC	—	—	159	—	170	130	—	140	100	152	109	70	116	75	—
28CB012	.193	SC	—	—	127	—	108	114	—	95	100	76	82	70	64	68	—
	4500	TC	—	—	170	—	—	140	—	151	108	163	116	75	125	80	—
	.212	SC	—	—	137	—	—	123	—	103	108	81	89	75	67	74	—
28CB008	2250	TC	134	115	97	124	104	86	112	92	73	99	78	58	84	62	39
	.195	SC	63	70	77	58	65	71	53	59	65	48	53	57	43	47	39
	3000	TC	150	130	110	139	118	98	126	105	83	113	90	67	96	72	47
28CB012	.244	SC	72	80	89	67	75	83	61	69	76	56	64	67	49	57	47
	3375	TC	155	135	115	145	123	103	132	110	87	118	94	70	101	76	50
	.268	SC	74	84	95	70	79	88	64	74	81	58	68	70	52	60	50
28CB012	3000	TC	—	159	129	—	140	109	152	119	86	129	94	—	102	—	—
	.160	SC	—	95	102	—	87	92	71	77	82	63	68	—	53	—	—
	4000	TC	—	—	152	—	163	129	—	140	103	151	112	67	121	74	—
28CB012	.198	SC	—	—	123	—	104	113	—	94	101	75	83	67	64	69	—
	4650	TC	—	—	163	—	—	139	—	151	112	162	121	76	130	83	—
	.223	SC	—	—	135	—	—	124	—	103	112	81	91	76	70	78	—

LEGEND

- BF — Bypass Factor
- CFM — Evaporator Airflow, Cfm
- SC — Sensible Capacity (1000 Btuh)
- TC — Total Capacity (1000 Btuh)

NOTES:

1. Direct interpolation is permissible. Do not extrapolate.
2. Fan motor heat has not been deducted.
3. Sensible Heat Capacity (SHC) is based on 80 F db temp of air entering the coil.
Below 80 F db, subtract (corr factor x cfm) from SHC.
Above 80 F db, add (corr factor x cfm) to SHC.

BYPASS FACTOR	ENTERING AIR DRY-BULB TEMP (F)					
	79	78	77	76	75	under 75
	81	82	83	84	85	over 85
Correction Factor						
.10	.98	1.96	2.94	3.92	4.91	use formula shown below
.20	.87	1.74	2.62	3.49	4.36	
.30	.76	1.53	2.29	3.05	3.82	

Interpolation is permissible.

$$\text{Correction Factor} = 1.09 \times (1 - \text{BF}) \times (\text{db} - 80)$$

4. For combination ratings with condensing units, see the Product Data catalog for 38ARZ units.

COIL STATIC PRESSURE DROP (in. wg)

UNIT	AIR QUANTITY (Cfm)										
	2250	2500	2750	3000	3250	3375	3500	3900	4000	4500	4650
28LA008	.144	.172	.204	.233	.275	.290	—	—	—	—	—
	.073	.089	.108	.128	.150	.160	—	—	—	—	—
28LA012	—	—	—	.180	.210	.226	.242	.300	.307	.397	—
	—	—	—	.127	.147	.157	.168	.205	.215	.265	—
28CB008	.16	.19	.21	.24	.27	.29	—	—	—	—	—
	.10	.12	.13	.15	.17	.18	—	—	—	—	—
28CB012	—	—	—	.14	.16	.17	.18	.22	.23	.28	.29
	—	—	—	.09	.10	.11	.11	.14	.15	.18	.19

LEGEND

- Wet Coil
- Dry Coil

Typical piping and wiring

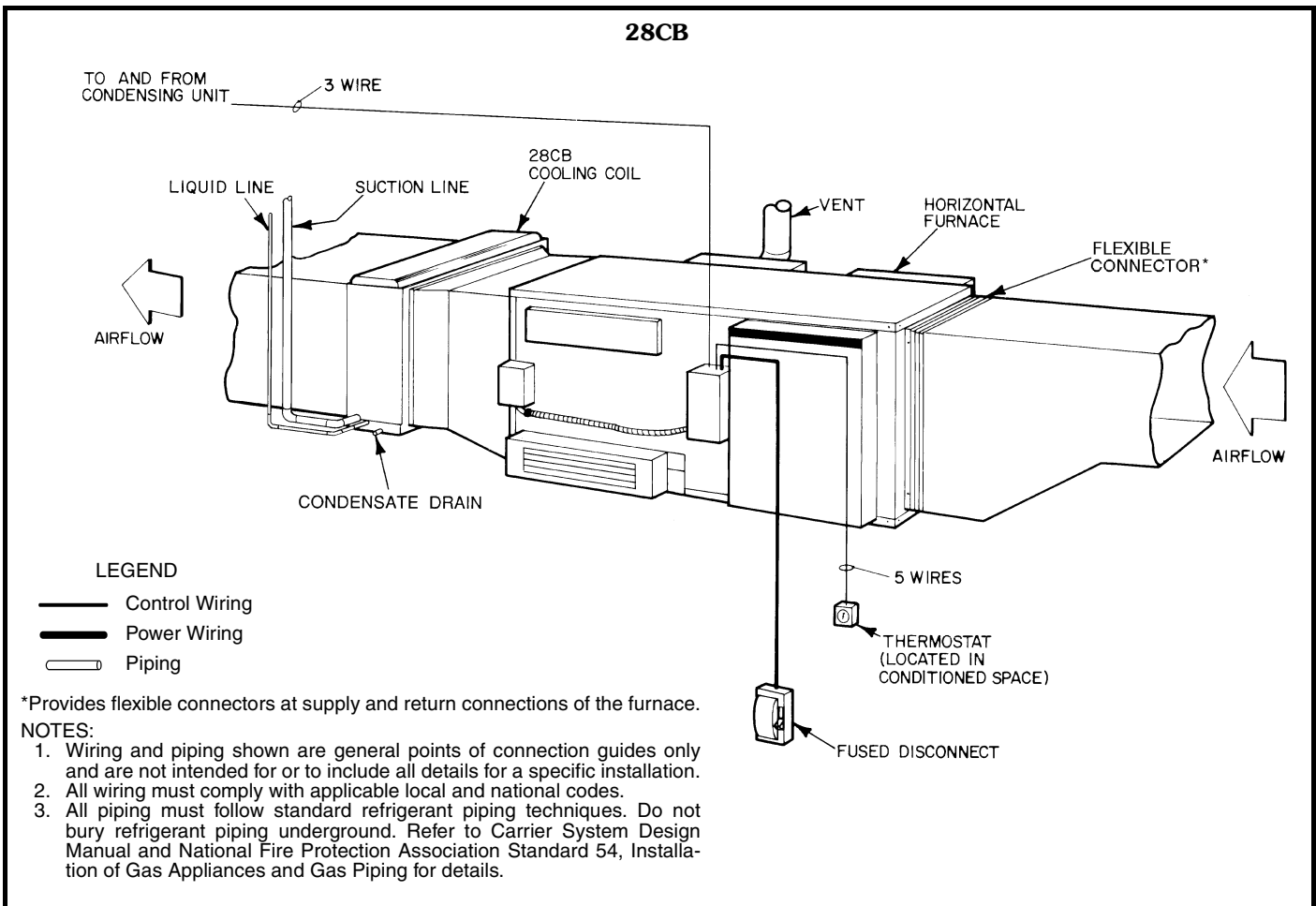
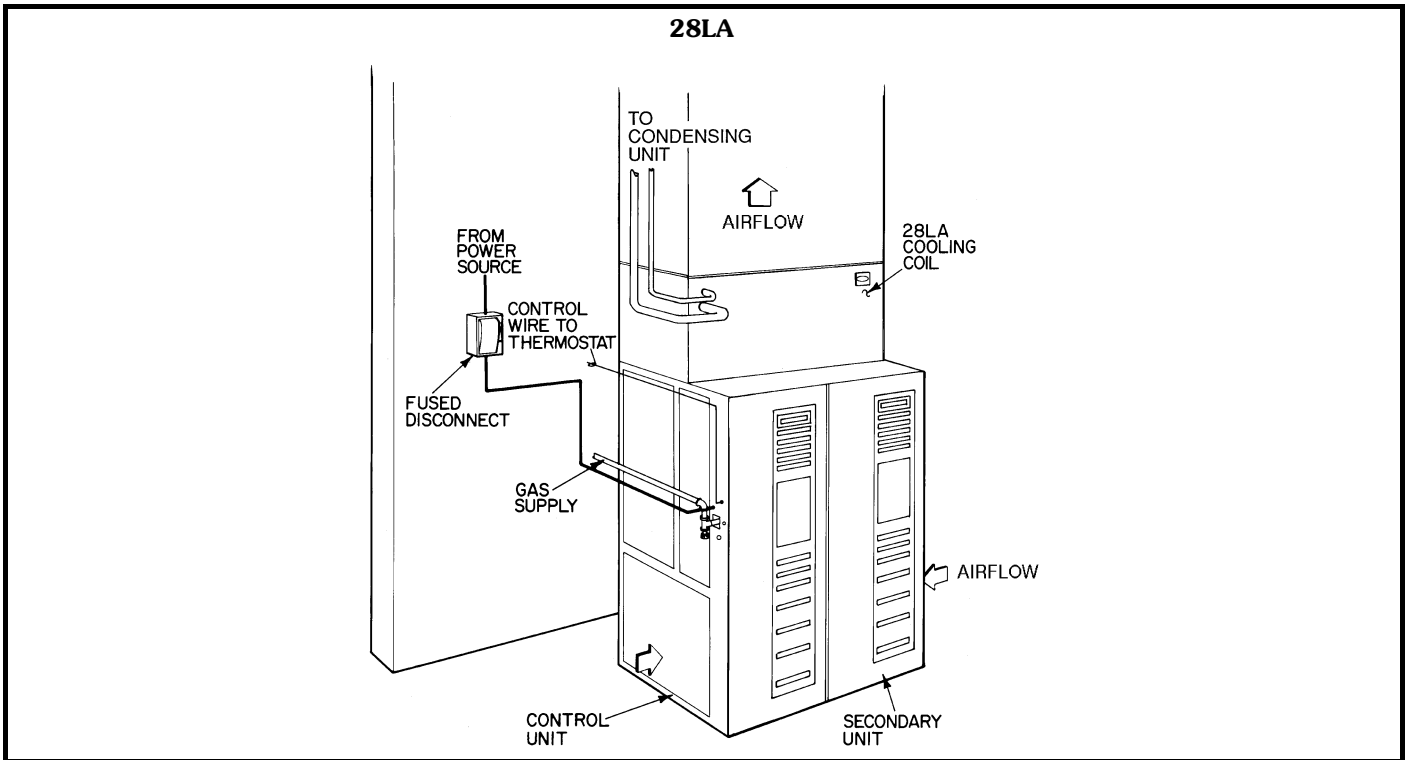

Application data



FACTORY-INSTALLED NOZZLE AND DISTRIBUTOR DATA

INDOOR COIL	EVAPORATOR SECTION	COIL FACE AREA (sq ft)	FACTORY-INSTALLED SPORLAN NOZZLE PART NO.	DISTRIBUTOR* CONNECTION (in.)
28LA008	Single	7.44	G8	5/8 ODF
28LA012	Single	9.79	E10	5/8 ODF
28CB008	Single	7.37	J5	5/8 Flare
28CB012	Single	10.35	G8	7/8 ODF†

LEGEND

ODF — Outside Diameter, Female

*Sporlan distributors are factory installed and require Sporlan nozzles.

†28CB012 is supplied with a 7/8 in. ODF to 5/8 in. SAE (Society of Automotive Engineers) flare nut adapter.

Guide specifications

Commercial Direct Expansion Coils

HVAC Guide Specifications

Size Range: **7 1/2 and 10 Tons, Nominal**

Carrier Model Numbers: **28LA, 28CB**

Furnish and install a _____ direct-expansion cooling coil in the location and manner shown on the plan.

Total cooling capacity of the coil shall be _____ Btuh or greater and sensible capacity shall be _____ Btuh or greater with _____ cfm of air entering coil at _____ F wet bulb and _____ F dry bulb. Coil refrigerant temperature shall be _____ F.

Cooling coil shall have a face area of not less than _____ sq ft and be constructed with aluminum plate fins mechanically bonded to nonferrous tubing with all joints brazed. Coil shall be _____ rows deep with a nominal fin spacing of _____ fins per inch.

The casing of encased coils shall be insulated and finished with baked enamel or equivalent corrosion-resistant surface. The casing material shall be cold-rolled steel (28LA) or galvanized steel (28CB). The 28CB coil casing shall allow space for attaching field-supplied thermostatic expansion valve.

Maximum unit dimensions shall be width of _____ in., depth of _____ in., and overall height of _____ inches.



Manufacturer reserves the right to discontinue, or change at any time, specifications or designs without notice and without incurring obligations.