

**38GXM / 40GXM
Multi-Split High-Wall Duct Free Split System
38GXM – Size 18k, 24k, and 30k
40GXM – Size 9k, 12k, and 18k**



Product Data

NOTE: Read the entire instruction manual before starting the installation.



INDUSTRY LEADING FEATURES / BENEFITS

AN INEXPENSIVE AND CREATIVE SOLUTION TO DESIGN PROBLEMS.

The 38GXM/40GXM duct free inverter driven multi split system provides individual comfort control for up to 4 separate zones. One, two, three or four space-saving High Wall duct free fan coils are matched with one outdoor heat pump. The indoor fan coils are connected to the outdoor unit by refrigerant tubing and wires.

The fan coils are mounted on the wall, near the ceiling. This selection of fan coils permits inexpensive and creative solutions to design problems such as:

- When adding air conditioning to spaces that are heated by hydronic or electric heat and have no ductwork.
- Historical renovations or any application where preserving the look of the original structure is essential.
- Commercial add-on jobs where the existing air conditioning system cannot be stretched.

These compact indoor fan coil units take up very little space in the room and do not obstruct windows. The fan coils are attractively styled to blend with most room decors.

Advanced system components incorporate innovative technology to provide reliable cooling and heating performance at low sound levels.

INVERTER TECHNOLOGY - COMFORT

The inverter driven compressor is designed to run at various input power frequencies (Hz) which controls the motor speed of the compressor.

Even Temperature – The control package, including the inverter, monitors outdoor and indoor temperatures as they relate to the selected indoor set point and adjusts the speed of the compressor to match the load and keep the system operating continuously rather than cycling and creating temperature swings. This translates to higher comfort levels for the occupants.

Rapid Pull Down/Warm-Up – Comfort is increased by the ability to the inverter system to ramp up the compressor speed enabling the system to reach the user selected room temperature set point quicker.

Humidity Control – Running the system for longer periods and continuously varying the compressor speed will enhance the humidity control.

INDIVIDUAL ROOM COMFORT

Maximum comfort is provided because each space can be controlled individually based on the usage pattern. The air sweep feature provided permits optimal room mixing to eliminate hot and cold spots for the occupant comfort.

LOW SOUND LEVELS

When noise is a concern, the duct free split systems are the answer. The indoor units are whisper quiet. There are no compressors indoors, either in the conditioned space or directly over it, and there is none of the noise usually generated by air being forced through ductwork.

When sound ordinances and proximity to neighbors demand quiet operation, the 38GXM unit is the right choice. With the inverter technology, these units run at lower speeds most of the time resulting in reduced sound levels.

INVERTER TECHNOLOGY – ENHANCED ECONOMICAL OPERATION

Duct free systems are inherently economical to operate. Individual rooms are heated or cooled only when required, and since the air is delivered directly to the space, there is no need to use additional energy to move the air in the ductwork. This economical operation is enhanced further when the inverter system output matches the load resulting in a more efficient system.

EASY-TO-USE CONTROLS

The high-wall systems have microprocessor-based controls to provide the ultimate in comfort and efficiency. The user friendly wireless remote control provides the interface between the user and the unit.

SECURE OPERATION

If security is an issue, outdoor and indoor units are connected only by refrigerant piping and wiring to prevent intruders from crawling through ductwork or wall openings. In addition since the 38GXM can be installed close to an outside wall, coils are protected from vandals and severe weather.

FAST INSTALLATION

This compact duct-free split system is simple to install. A mounting bracket is included with the indoor units and only wires and piping need to be run between the indoor and outdoor units. These units are fast and easy to install ensuring minimal disruption to customers in homes or workplace. This makes the 38/40GXM systems the equipment of choice for retrofit applications.

SIMPLE SERVICING AND MAINTENANCE

Removing the top panel of the outdoor unit provides immediate access to the control compartment, providing the service technician access to the diagnostic LEDs to facilitate the troubleshooting process. In addition, the draw-thru design of the outdoor unit means that dirt accumulates on the outside surface of the coil. Coils can be cleaned quickly from the inside using a pressure hose and detergent.

On the indoor units, service and maintenance expense is reduced due to the permanent easy to clean filters. Also, error codes are displayed on the front panel to alert the user to certain system malfunctions

BUILT-IN RELIABILITY

Duct-free split system indoor and outdoor units are designed to provide years of trouble-free operation.

Both the indoor and outdoor units are well protected. Whenever the microprocessor detects abnormal conditions, the unit will stop and an error code is displayed.

Inverter systems provide additional reliability due to soft start. This refers to the ability of the inverter to start the compressor motor using reduced voltage and reduced current. This feature is beneficial from an electrical standpoint (eliminates current spikes) as well as an overall reliability standpoint due to reduced stress on all associated system components.

ACCESSORIES

A condensate pump accessory is available to provide installation flexibility for those applications where gravity cannot be used to dispose of the condensate.

AGENCY LISTINGS

All systems are listed with AHRI (Air conditioning, Heating, and Refrigeration Institute) and are ETL certified per UL 1995 standard.

MODEL NUMBER NOMENCLATURE

INDOOR UNIT

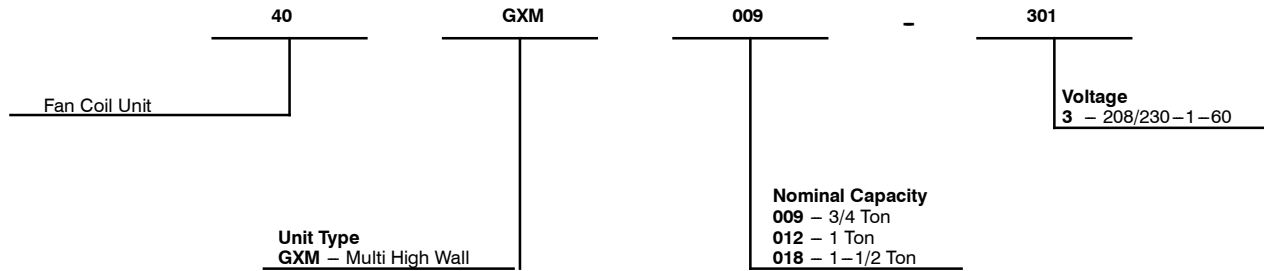

OUTDOOR UNIT

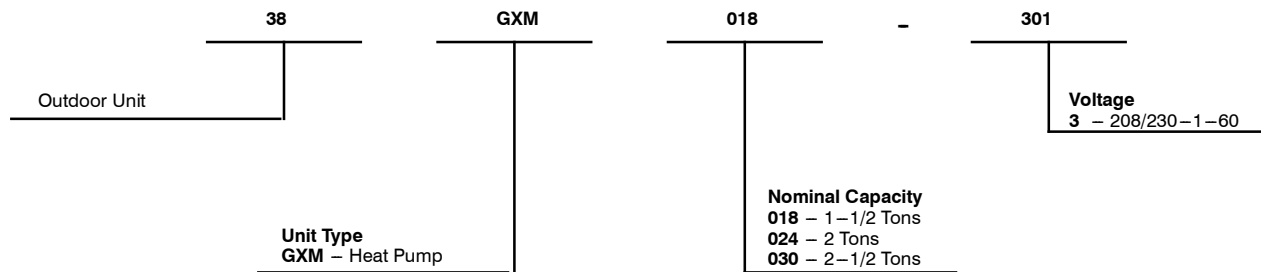

38/40GXM



Use of the AHRI Certified TM Mark indicates a manufacturer's participation in the program. For verification of certification for individual products, go to www.ahrirectory.org.



STANDARD FEATURES AND ACCESSORIES

Ease of Installation	
Mounting Bracket	S
Low Voltage Controls	S
Comfort Features	
Microprocessor Control	S
Wireless Remote Control	S
Rapid Cooling and Heating	S
Automatic Air Sweep	S
Cold Blow Prevention	S
Continuous Fan	S
Auto Restart Function	S
Auto Changeover	S
Energy Saving Features	
Inverter Driven Compressor	S
Sleep Mode	S
24 Hour Stop/Start Timer	S
Safety And Reliability	
Indoor Unit Freeze Protection	S
3 Minute Compressor Time Delay	S
High Compressor Discharge Temperature	S
Low Voltage Protection	S
Compressor Overload Protection	S
Compressor Over Current Protection	S
IPM Module Protection	S
Ease of Service	
Cleanable Filters	S
Diagnostic LED's On Outdoor Board	S
Error Messages Displayed On Front Panel	S
Application Flexibility	
Condensate Pumps	A
Standard Warranty	
6 Years Compressor limited Warranty*	S
2 year Parts Limited Warranty*	S
Extended Warranty	
6 – 10 Year Compressor Only	O
2 – 6 Year Parts Only	O
2 – 6 Year Parts; 1 – 6 Year Labor	O
2 – 6 Year Parts; 6 – 10 Yr Compr. Only; 1 – 6 Yr Labor	O

Legend

- S Standard
- A Accessory
- O Optional
- F Field Fabricated

* For Residential applications. For Commercial applications, warranty is 1 year for parts and 5 years for compressor.

INDOOR UNITS

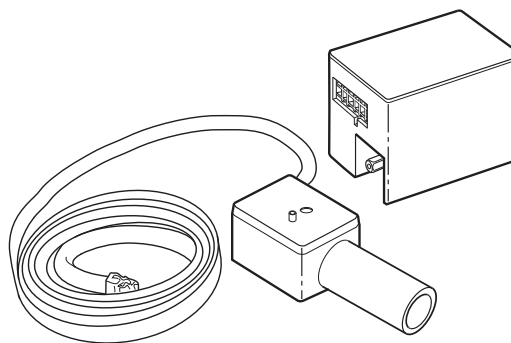

A07892

Fig. 1 – Condensate Pump Accessory

On high wall fan coils, the condensate pump accessory is recommended when adequate drain line pitch cannot be provided, or when the condensate must move up to exit.

The pump has a lift capability of 12 ft (3.6 m) on the discharge side if the pump is mounted in the fan coil or 6 ft (1.8 m) on the suction side if the pump is remote mounted.

AHRI* CAPACITY RATINGS

Model Numbers		Cooling			High Heating 47° F		Low Heating 17° F
Outdoor Unit	Indoor Unit	Capacity (Btuh)	EER	SEER	Capacity (Btuh)	HSPF	Capacity (Btuh)
38GXM218---3	2 x 40GXM009---3	16,500	8.9	14.0	18,000	7.9	12,000
38GXM224---3	2 x 40GXM012---3	24,000	9.6	14.5	27,000	8.3	17,065
38GXM430---3	4 x 40GXM009---3	26,000	8.0	14.5	28,000	8.4	17,350

*Air Conditioning, Heating & Refrigeration Institute

-- = N/A

Legend

- HSPF – Heating Seasonal Performance Factor
- SEER – Seasonal Energy Efficiency Ratio

NOTES:

- Ratings are net values reflecting the effects of circulating fan heat. Ratings are based on: Cooling Standard: 80°F (26.67°C) db, 67°F (19.44°C) wb air entering indoor unit and 95°F (35°C) db air entering outdoor unit. High Temperature Heating Standard: 70°F (21.11°C) db air entering indoor unit and 47°F (8.33°C) db, 43°F (6.11°C) wb air entering outdoor unit.
- Ratings are based on 25 ft. (7.62 m) of interconnecting refrigerant lines.
- All system ratings are based on fan coil units operating at high fan speed. Consult Physical Data tables for air flows at all available fan speeds.

DIMENSIONS - INDOOR

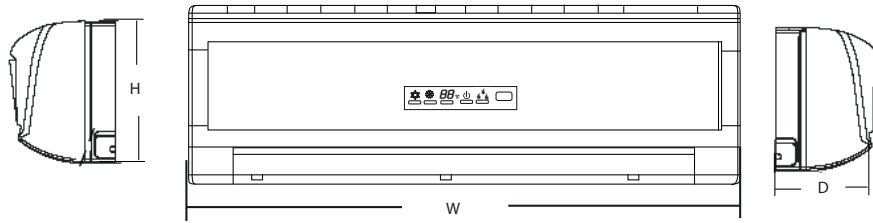

A08289

Unit Size	W In. (mm)	H In. (mm)	D In. (mm)	Net Operating Weight Lbs. (Kg)
9k	30.3 (770)	9.8 (249)	7.84 (199)	18.7 (8.5)
12k	32.7 (831)	11.2 (284)	8.9 (226)	24.2 (11)
18k	40.2 (1021)	12.2 (310)	9.0 (229)	28.6 (13)

DIMENSIONS - OUTDOOR

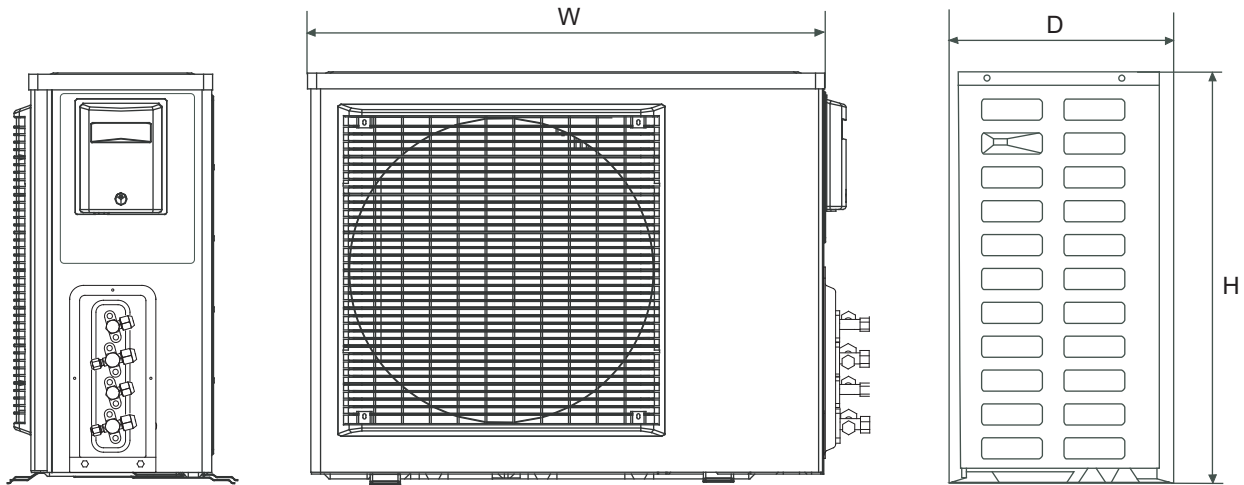

A08290

Unit Size	W In. (mm)	D In. (mm)	H In. (mm)	Net Operating Weight Lbs. (Kg)
18k	33.3 (846)	11.8 (300)	27.0 (685)	114.4 (52)
24k	37.4 (950)	16.5 (420)	33.1 (840)	150.0 (68)
30k	37.4 (950)	16.5 (420)	33.1 (840)	165.0 (75)

38/40GXIM

CLEARANCES - INDOOR

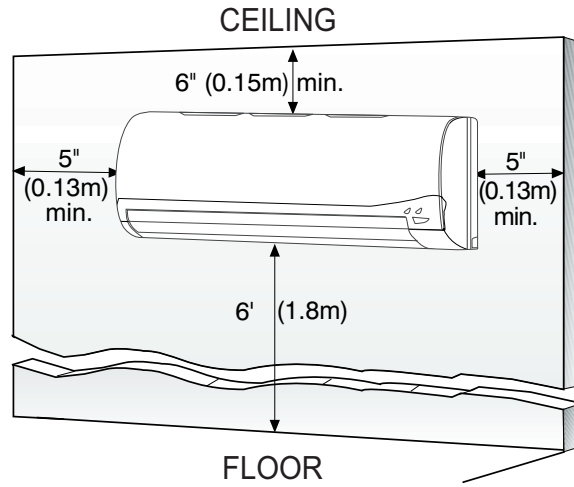

A07891

Fig. 2 – Indoor unit clearance

38/40GX

CLEARANCES - OUTDOOR

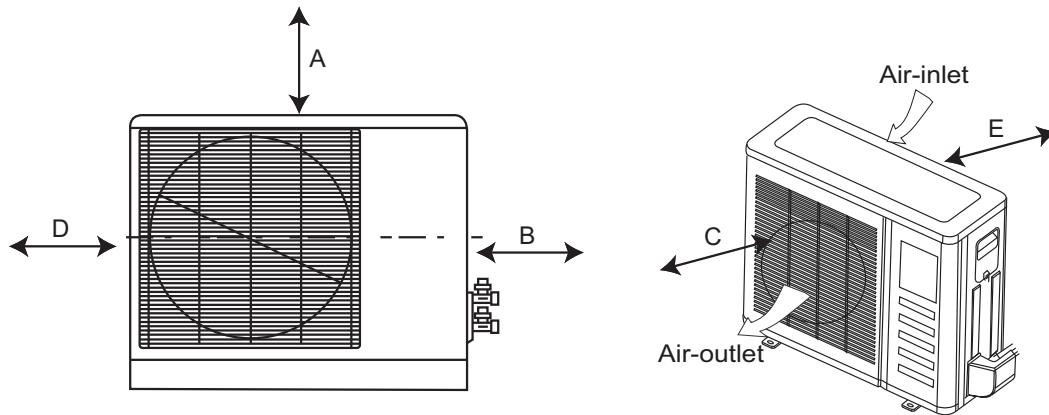

A07894

UNIT	12k in. (mm)
A	20 (508)
B	20 (508)
C	24 (610)
D	12 (305)
E	24 (510)

Fig. 3 – Outdoor Unit Clearance

PHYSICAL DATA - 38GXM

Outdoor Unit 38GXM	018	024	030
System Voltage	208/230 – 1 – 60		
Control Voltage	Low Voltage Pulse DC		
Rated Cooling Capacity (Btuh)	16,500	24,000	26,000
Rated Heating Capacity (Btuh)	18,000	27,000	28,000
Operating Weight lb (kg)	114.4 (52)	150.0 (68)	165 (75)
Refrigerant Type	R-410A		
Metering Device	EXV at Outdoor Unit		
Charge lb (kg)	3.5 (1.6)	5.5 (2.5)	7.3 (3.3)
Compressor			
Type	Inverter Driven Rotary		
Model	C-6RVN93H0V	C-7RZ233H1A	
Outdoor Fan			
CFM	TBD	TBD	TBD
RPM	780/600		860/760/540
Diameter (in) ... No. of Blades	18.7 ... 3		
Watts watts	60		
Outdoor Coil			
Face Area (sq.ft)	5.7	6.0	7.0
No. Rows	2		
No. of Circuits	TBD		
Fins per inch	18		
Refrigerant Lines			
Connection Type	Flare		
Liquid (Mix Phase) in OD	1/4"		
Vapor Line in OD	3/8"	1/2"	3/8"
Total Piping ft. (m.)	124 (38)*		230 (70)*
Max Piping to Any FCU ft. (m.)	82 (25)		
Max Lift (Fan Coil Above) ft	49 (15)		
Max Drop (Fan Coil Below) ft	33 (10)		
External Finish	White		

*Refer to Long Line Application section on page 11

38/40GXM

PHYSICAL DATA - 40GXM

Indoor Unit 40GXM	009	012	018
System Voltage	208/230 – 1 – 60		
Control Voltage	Low Voltage Pulse DC		
Electrical Connections	Indoor Unit Powered From Outdoor Unit		
Rated Cooling Capacity (Btuh)	16,500	24,000	26,000
Rated Heating Capacity (Btuh)	18,000	27,000	28,000
Operating Weight lb (kg)	18.7 (8.5)	24.2 (11)	26.4 (12)
Refrigerant Type	R-410A		
Metering Device	EXV at the outdoor unit		
Moisture Removal Rate (pints/hr)	TBD		
Indoor Fan			
RPM/CFM (Turbo)	1150/283	1250/341	1350/368
RPM/CFM (High)	1050/247	1050/288	1200/330
RPM/CFM (Medium)	900/212	950/253	1050/280
RPM/CFM (Low)	750/182	800/194	900/218
Motor Watts	14	14	14
Blower Quantity ... Size in	1 ... 3.8 x 23	1 ... 3.6 x 24.3	1 ... 3.8 x 31.4
Indoor Coil			
Face Area (sq.ft)	2.4	2.4	3.2
No. Of Rows	2		
Fins Per Inch	16	18	16
Number Of Circuits	2	3	3
Filters			
Quantity	2		
Controls			
Intergrated Microprocessor			
Wireless Remote	Standard		
Modes	Cool/Heat/Dry/Auto		
Fan Mode	High/Medium/Low/Auto		
Emergency Mode	Yes		
Defrost Method	Demand Defrost		
Diagnostics	Yes		
Air Sweep	Yes		
Soft Start	Yes		
Rapid Cooling/Heating	Yes		
Cold Blow Prevention	Yes		
Sleep Mode	Yes		
24 Hour Timer	Yes		
Auto Restart	Yes		
Freeze Protection On Indoor Unit	Yes		
Refrigerant Lines			
Connection Type	Flare		
Liquid (Mix Phase) in OD	1/4"		
Vapor Line in OD	3/8"	1/2"	3/8"
Total Piping ft. (m.)	124 (38)*		230 (70)*
Max Piping to Any FCU ft. (m.)	82 (25)		
Max Lift (Fan Coil Above) ft	49 (15)		
Max Drop (Fan Coil Below) ft	33 (10)		
Condensate Drain			
Size in	ID = 1/2" OD = 5/8"		
External Finish	White		

*Refer to Long Line Application section on page 11

38/40GXM

APPLICATION DATA

UNIT SELECTION

When selecting a variable speed system match the system capacity range to the anticipated load range. Since a variable speed system can accommodate a wide range of loads it is important to understand the percentage of time that the system will be required to run at the both the maximum and the minimum load points. This differential is most evident when a residential application is compared with a commercial application.

Generally there will be more load diversification in the residential application (shifting from low load to high load).

The commercial application will tend to be more steady during the normal day time hours, and will go to low load levels after normal business hours. If it is anticipated that the system will be required to run at the maximum load point for the majority of the time, the next larger system capacity should be selected.

The tables below are guidelines for selecting the proper size for the application.

CAPACITIES

18K - COOLING

Fan Coil Combinations	FCU 1 BTUH	FCU 2 BTUH	Cooling Capacity BTUH	Cooling Capacity Range BTUH
1 x 40GXM009-3	9,300	-	9,300	4,900 - 12,500
1 x 40GXM012-3	10,200	-	10,200	5,100 - 12800
2 x 40GXM009-3	8,800	8,800	17,600	3,750 - 19,600
1 x 40GXM009-3 1 x 40GXM012-3	8,500	9,800	18,300	3,450 - 21,300

18K - HEATING

Fan Coil Combinations	FCU 1 BTUH	FCU 2 BTUH	Heating Capacity BTUH	Heating Capacity Range BTUH
1 x 40GXM009-3	9,600	-	9,600	3,700 - 10,600
1 x 40GXM012-3	10,600	-	10,600	3,900 - 11,700
2 x 40GXM009-3	9,100	9,100	18,200	8,200 - 19,800
1 x 40GXM009-3 1 x 40GXM012-3	9,000	10,300	19,300	8,800 - 21,000

24K - COOLING

Fan Coil Combinations	FCU 1 BTUH	FCU 2 BTUH	Cooling Capacity BTUH	Cooling Capacity Range BTUH
1 x 40GXM009-3	14,100	-	14,100	12,700 - 16,700
1 x 40GXM012-3	15,600	-	15,600	14,200 - 18,600
2 x 40GXM009-3	11,400	11,400	22,800	11,800 - 25,500
1 x 40GXM009-3 1 x 40GXM012-3	11,000	13,000	24,000	12,300 - 26,800
1 x 40GXM012-3 1 x 40GXM012-3	12,775	12,775	25,050	12,850 - 28,000

24K - HEATING

Fan Coil Combinations	FCU 1 BTUH	FCU 2 BTUH	Heating Capacity BTUH	Heating Capacity Range BTUH
1 x 40GXM009-3	12,900	-	12,900	10,500 - 15,000
1 x 40GXM012-3	14,500	-	14,500	11,600 - 16,800
2 x 40GXM009-3	12,100	12,100	24,200	10,100 - 26,600
1 x 40GXM009-3 1 x 40GXM012-3	11,800	14,300	26,100	10,900 - 28,700
1 x 40GXM012-3 1 x 40GXM012-3	14,200	14,200	28,000	11,400 - 31,200

CAPACITIES (CONTINUED)

30K - COOLING

Fan Coil Combinations	FCU 1 BTUH	FCU 2 BTUH	FCU 3 BTUH	FCU 4 BTUH	Cooling Capacity BTUH	Cooling Capacity Range BTUH
2 x 40GXM009-3	8,530	8,530	-	-	17,600	11,200 - 22,800
1 x 40GXM009-3 1 x 40GXM012-3	8,500	11,900	-	-	20,400	11,200 - 26,600
1 x 40GXM009-3 1 x 40GXM018-3	8,800	15,300	-	-	24,100	11,200 - 32,400
2 x 40GXM012-3	11,900	11,900	-	-	23,800	11,200 - 28,000
1 x 40GXM012-3 1 x 40GXM018-3	11,900	12,300	-	-	24,200	11,200 - 32,400
3 x 40GXM009-3	8,100	8,100	8,100	-	24,300	11,200 - 32,400
2 x 40GXM009-3 1 x 40GXM012-3	7,200	7,200	9,900	-	24,300	11,200 - 32,400
2 x 40GXM009-3 1 x 40GXM018-3	7,500	7,500	9,200	-	24,200	11,200 - 32,400
1 x 40GXM009-3 2 x 40GXM012-3	6,500	8,900	8,900	-	24,300	11,200 - 32,400
1 x 40GXM009-3 1 x 40GXM012-3 1 x 40GXM018-3	7,200	7,800	9,200	-	24,200	11,200 - 32,400
2 x 40GXM012-3 1 x 40GXM018-3	7,800	7,800	8,500	-	24,100	11,200 - 32,400
4 x 40GXM009-3	6,800	6,800	6,800	6,800	27,200	11,200 - 32,400
3 x 40GXM009-3 1 x 40GXM012-3	6,000	6,000	6,000	9,400	27,400	11,200 - 32,400
3 x 40GXM009-3 1 x 40GXM018-3	5,500	5,500	5,500	11,100	27,600	11,200 - 32,400
2 x 40GXM009-3 2 x 40GXM012-3	5,100	5,100	8,500	8,500	27,200	11,200 - 34,100
1 x 40GXM009-3 2 x 40GXM012-3 1 x 40GXM018-3	5,400	5,600	5,600	11,000	27,600	11,200 - 34,100
4 x 40GXM012-3	6,800	6,800	6,800	6,800	27,200	11,200 - 34,100

38/40GXM

30K - HEATING

Fan Coil Combinations	FCU 1 BTUH	FCU 2 BTUH	FCU 3 BTUH	FCU 4 BTUH	Cooling Capacity BTUH	Cooling Capacity Range BTUH
2 x 40GXM009-3	10,900	10,900	-	-	21,800	8,700 - 28,000
1 x 40GXM009-3 1 x 40GXM012-3	10,900	13,600	-	-	24,500	8,700 - 29,000
1 x 40GXM009-3 1 x 40GXM018-3	9,900	17,100	-	-	27,000	10,200 - 31,700
1 x 40GXM012-3 1 x 40GXM012-3	13,300	13,300	-	-	26,600	10,200 - 31,700
1 x 40GXM012-3 1 x 40GXM018-3	12,300	15,400	-	-	27,700	10,600 - 33,800
3 x 40GXM009-3	9,200	9,200	9,200	-	27,600	10,600 - 33,800
2 x 40GXM009-3 1 x 40GXM012-3	8,500	8,500	10,600	-	27,600	10,600 - 33,800
2 x 40GXM009-3 1 x 40GXM018-3	8,000	8,000	11,600	-	27,600	10,600 - 33,800
1 x 40GXM009-3 2 x 40GXM012-3	7,500	10,400	10,400	-	28,300	10,600 - 33,800
1 x 40GXM009-3 1 x 40GXM012-3 1 x 40GXM018-3	7,500	9,200	10,900	-	27,600	10,600 - 33,800
2 x 40GXM012-3 1 x 40GXM018-3	8,500	8,500	10,600	-	27,600	10,600 - 33,800
4 x 40GXM009-3	8,200	8,200	8,200	8,200	32,800	11,300 - 37,500
3 x 40GXM009-3 1 x 40GXM012-3	7,500	7,500	7,500	10,200	32,700	11,300 - 37,500
3 x 40GXM009-3 1 x 40GXM018-3	7,200	7,200	7,200	11,200	32,800	11,300 - 37,500
2 x 40GXM009-3 2 x 40GXM012-3	7,200	7,200	9,200	9,200	32,800	11,300 - 37,500
1 x 40GXM009-3 2 x 40GXM012-3 1 x 40GXM018-3	7,100	8,000	8,100	10,300	33,400	11,300 - 37,500
4 x 40GXM012-3	8,250	8,250	8,250	8,250	33,000	11,300 - 37,500

UNIT MOUNTING (INDOOR)

Mounting Bracket – The fan coil units are furnished with mounting bracket to hang the unit.

Support – Adequate support must be provided to handle the weight of all fan coils. Refer to the Physical Data section for weights, and the base unit dimensional drawings.

Unit Leveling – For reliable operation, units should be level in all planes.

Clearances – Minimum clearance as shown in Fig. 2.

Unit location – Select a location which will provide the best air circulation for the room. These units should be positioned as high as possible on the wall for the best air circulation. The unit return and discharge should not be obstructed by furniture, curtains, or anything which may cause the unit to short cycle or air to recycle. Place the unit in the middle of the selected wall (if possible). Use an outside wall, if available, to make piping easier, and place the unit so it faces the normal location of room occupants.

UNIT MOUNTING (OUTDOOR)

Support – A location which can bear the weight of outdoor unit. Refer to the Physical Data section for weights, and base dimensional drawings.

Unit Leveling – For reliable operation, units should be level in all planes.

Clearances – Minimum clearances, as shown in Fig. 3, must be provided for airflow. The outdoor units are designed for free-blow applications. Air inlets and outlets should not be restricted.

Unit location – A location which is convenient to installation and not exposed to strong wind.

SYSTEM OPERATING CONDITIONS

Cooling operating range:

	Maximum		Minimum	
	DB °F (°C)	WB °F (°C)	DB °F (°C)	WB °F (°C)
Outdoor Unit	115 (46.1)	–	55 (12.8)	–
Indoor Unit	95 (35)	–	55 (12.8)	–

Heating operating range:

	Maximum		Minimum	
	DB °F (°C)	WB °F (°C)	DB °F (°C)	WB °F (°C)
Outdoor Unit	75 (23.9)	–	14 (–10)	–
Indoor Unit	80 (26.7)	–	55 (12.8)	–

METERING DEVICES

The outdoor unit has multiple electronic expansion valves to manage the refrigerant flow to the different indoor fan coils connected to that unit.

REFRIGERANT LINES

Routing – Refrigerant lines can be routed in any of the four directions shown in Fig. 4.

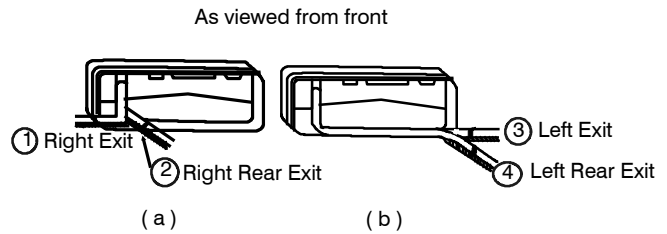

Fig. 4 – Refrigerant Line Routing

A08281

General Guidelines:

1. The 38GXM units are shipped with full charge of R-410A refrigerant. All charges, line sizing, and capacities are based on runs of 16 ft (9.1 m) for units sizes 18 and 24K, and 30 ft. (9.1 m.) for size 30K. For runs over the previous limits, consult long line section for charge adjustments.
2. Refrigerant lines should not be buried in the ground. If it is necessary to bury the lines, not more than 36 inches (914 mm) should be buried. Provide a minimum of 6 inch (152 mm) vertical rise to service valves to prevent refrigerant migration.
3. Both lines must be insulated. Use a minimum of ½-inch (12.7 mm) thick insulation. Closed-cell insulation is recommended in all long-line applications.
4. Special consideration should be given to isolating interconnecting tubing from the building structure. Isolate the tubing so that vibration or noise is not transmitted into the structure.

Long Line Applications:

1. No change in line sizing is required.
2. For line lengths above the mentioned in the general guidelines section, add 0.24 oz. per additional foot of piping up to the maximum allowed.

38/40GXM

DRAIN CONNECTIONS

Install drains to meet the local sanitation codes. If adequate gravity drainage cannot be provided, a field installed condensate pump accessory should be used. The pump has a lift capability of 12 ft (3.6 m) on the discharge side if the pump is mounted in the fan coil or 6 ft (1.8 m) on the suction side if the pump is remote mounted. See the Physical Data tables for drain sizes.

NOTE: The high wall fan coils have internal condensate trap. An external trap is not required.

Drain connections may be routed through alternate locations as shown in Fig. 5.

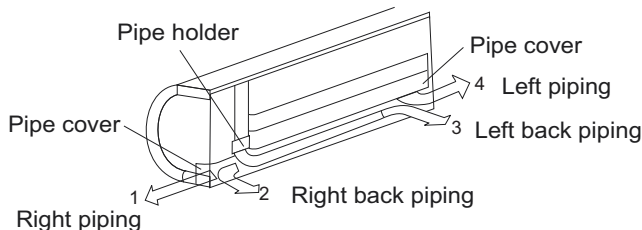

A09112

Fig. 5 – Piping Locations

WIRING

The main power is supplied to the outdoor unit. The field supplied connecting cables from the outdoor unit to each of the indoor units consists of 4 wires: L1, L2, Ground, and S for communication between the outdoor unit and each indoor unit.

CONTROL SYSTEM

The 38/40GXM unit is equipped with a microprocessor controls to operate the system and give optimum levels of comfort and operating efficiency.

There are microprocessor boards and thermistors located in both the indoor and outdoor units. The thermistors monitor the system operation and control the operating mode. The change in the settings or the modes of operation, use the factory supplied wireless remote control.

The 38/40GXM unit has the following operating modes:

- Fan Only
- Auto
- Heating (on Heat Pumps only)
- Cooling
- Dehumidification (Dry)

FAN ONLY - In Fan Only mode, the system filters and circulates the room air without changing the room air temperature.

AUTO - In Auto mode, the system will automatically select one of the following operating modes: cooling, heating or fan only based on the difference between the room temperature and the set point temperature.

HEATING - In the Heating mode, the system heats and filters room air.

COOLING - When in Cooling mode, the fan runs all the time and the system cools, dries and filters room air.

DEHUMIDIFICATION (DRY) - in Dehumidification (Dry) mode, the system dries, filters and slightly cools room temperature. This mode does not take place of a dehumidifier.

In addition to the above modes that are selected by using the remote control, the unit can run in emergency mode by using a manual button. This mode is used when the remote is misplaced or the batteries in the remote have died. In this mode, the unit will run in AUTO mode with a predetermined set point (76°F/24.4°C)

WIRELESS REMOTE CONTROL

1. A wireless remote control is supplied for system operation.
2. Each battery-operated wireless remote control may be used to control more than one unit.
3. The wireless remote control has a range of 25 ft. (7.6 m).

SEQUENCE OF OPERATION

Simultaneous heating and cooling is not allowed. At start-up, the first indoor unit to call for operation (heating or cooling) will control from the preset position, the mode of operation for the rest of the indoor units connected to the same outdoor unit. If the other units conflict in mode with the first unit an error message will be displayed on those units.

When a unit is set to COOL, HEAT or DRY mode, the electronic expansion valve is first initialized (closed) and then is opened to a preset position.

Superheat heat for each fan coil (the ones that are energized) is monitored and the position of the electronic expansion valve is adjusted to ensure that each fan coil gets the appropriate amount of refrigerant to maintain the required superheat. After the set point is satisfied and the fan coil shuts off, the electronic expansion valve stays open for a specified time to ensure that system pressures equalize.

When the system is set for COOL, HEAT or DRY mode, the compressor speed is varied by comparing the indoor air temperature with the set point and continuously adjusting the compressor speed (to keep the compressor running as long as possible) in an effort to maintain the greatest comfort possible.

The indoor fan can be running in MANUAL or AUTO mode. When the fan is running in AUTO mode, the speed is determined by comparing the room temperature to the set point.

In COOLING mode, when the set point is satisfied, the fan will continue running. In HEATING mode, when the set point is satisfied, the fan speed will be reduced and then will run continuously until the coil temperature drops to a point cold air is blown on the occupants in the space, at which time the indoor fan is de-energized.

When the unit goes through the defrost cycle, the indoor fans are de-energized and the refrigerant is circulated through all the fan coils (even if they were off or on standby before the defrost cycle) to maximize the heat transfer surface area available for defrost operation.

AIR THROW DATA

Model Number	Approximate Air Throw ft. (m)			
	Low	Medium	High	Turbo
40GXM009---3	20 (6.1)	22 (6.7)	25 (7.6)	28 (8.5)
40GXM012---3	22 (6.7)	25 (7.6)	27 (8.2)	31 (9.4)
40GXM018---3	23 (7.0)	29 (8.8)	32 (9.8)	35 (10.7)

SOUND RATINGS

Outdoor Units

Model Number	Sound Power dBA	Sound Pressure dBA
38GXM218---3 (cool/heat)	68/68	57/57
38GXM224---3 (cool/heat)	68/68	57/57
38GXM430---3 (cool/heat)	70/70	59/59

Indoor Units

Model Number	Low		Medium		High		Turbo	
	Sound Power dBA	Sound Pressure dBA	Sound Power dBA	Sound Pressure dBA	Sound Power dBA	Sound Pressure dBA	Sound Power dBA	Sound Pressure dBA
40GXM009---3 (cool/heat)	42.0	31.0	47.0	36.0	51.0	40.0	54.0	43.0
40GXM012---3 (cool/heat)	44.0	33.0	46.0	35.0	48.0	47.0	53.0	42.0
40GXM018---3 (cool/heat)	52.0	41.0	55.0	44.0	57.0	46.0	60.0	49.0

NOTES:

1. Sound power ratings are per AHRI 270 and AHRI 350
2. Sound pressure ratings are estimated sound pressure, 3 feet (.91 m) from the unit, based on sound power data.

ELECTRICAL DATA

UNIT SIZE	SYSTEM VOLTAGE	OPERATING VOLTAGE*	COMPRESSOR		OUTDOOR FAN			INDOOR FAN†				MCA	MAX FUSE/CB AMP
	VOLT-PH-HZ	MAX/MIN	RLA	LRA	FLA	HP	W	VOLTS	FLA	HP	W		
18 K	208/230-1-60	253/187	3.8	41	0.65	0.082	60	208/230-1-60	0.26	0.19	14	14	20
24 K			8.2	34								0.68	20
30 K			24	40									

* Permissible limits of the voltage range at which the unit will operate satisfactorily

† Indoor fan powered from outdoor unit.

LEGEND

FLA – Full Load Amps

LRA – Locked Rotor Amps

MCA – Minimum Circuit Amps

RLA – Rated Load Amps

PART 1 – GENERAL

1.01 System Description

- A. Outdoor air-cooled split system compressor sections suitable for on-the-ground, rooftop, wall hung or balcony mounting. Units shall consist of a variable speed rotary compressor, an air-cooled coil, propeller-type draw-through outdoor fan, reversing valve, accumulator, electronic expansion valves, multiple service valves, and controls that allows multiple indoor units to be connected to the outdoor unit. Units shall discharge horizontally as shown on the contract drawings. Units shall function as the outdoor component of an air-to-air heat pump system.
- B. Units shall be used in a refrigeration circuit matched to one, two, three or four High Wall duct-free heat pump fan coil units.

1.02 Agency Listings

- A. Unit construction shall comply with ANSI/ASHRAE 15, latest revision, and with NEC.\
- B. Units shall be evaluated in accordance with UL standard 1995.
- C. Units shall be listed in CEC directory.
- D. Unit cabinet shall be capable of withstanding 500-hour salt spray test per Federal Test Standard no. 141 (method 6061).
- E. Air-cooled condenser coils shall be leak tested at 573 psig.

1.03 Delivery, Storage, And Handling

Units shall be shipped in one piece and shall be stored and handled per manufacturer’s recommendations.

1.04 Warranty (For Inclusion By Specifying Engineer)

PART 2 – PRODUCTS

2.01 Equipment

A. General:

Factory assembled, single piece, air-cooled outdoor unit. Contained within the enclosure shall be all factory wiring, piping, controls, and compressor.

B. Unit Cabinet:

- 1. Unit cabinet shall be constructed of galvanized steel, bonderized and coated with baked-enamel finish on inside and outside.
- 2. Unit access panel should be removable with minimal screws and shall provide full access to the compressor, fan, and control components.
- 3. Outdoor compartment shall be isolated and have an acoustic lining to assure quiet operation.

C. Fans:

- 1. Outdoor fans shall be direct-drive propeller type, and shall discharge air horizontally. Fan shall draw air through the outdoor coil.
- 2. Outdoor fan motors shall be multi-speed, totally-enclosed, single phase motors with permanently lubricated ball bearings. Motor shall be protected by internal thermal overload protection.
- 3. Shaft shall have inherent corrosion resistance.
- 4. Outdoor fan openings shall be equipped with PVC metal/mesh coated protection grille over fan.

D. Compressor

- 1. Compressor shall be fully hermetic variable speed rotary type.
- 2. Compressor shall be three phase, inverter driven.
- 3. Compressor shall be equipped with oil system, operating oil charge, and motor.
- 4. Motor shall be suitable for operation in refrigerant and oil atmosphere.
- 5. Compressor assembly shall be installed on rubber vibration isolators.
- 6. The inverter and compressor shall be protected against over temperature and over current.

E. Outdoor Coil:

Coil shall be constructed of Aluminum fins mechanically bonded to seamless copper tubes, which are cleaned, dehydrated and sealed.

F. Refrigerant Components:

Refrigerant circuit components shall include multiple brass external liquid line service valves with service gauge port connections, multiple suction line service valves with service gage connection port, accumulator, reversing valve, electronic expansion valves.

G. Safeties:

Operating safeties shall be factory selected, assembled, and tested. The minimum functions shall include the following:

- 1. Compressor discharge over temperature protection.
- 2. System low voltage protection.
- 3. Compressor overload protection.
- 4. Compressor over current protection.
- 5. IPM module protection.

H. Electrical Requirements:

- 1. Units shall operate on single-phase, 60 Hz power at 208/230 v.
- 2. Unit electrical power shall be a single point connection.
- 3. All power and control wiring must be installed per NEC and all local electrical codes.
- 4. Units shall have multiple terminal blocks to connect to multiple indoor units.

INDOOR WALL-MOUNTED DUCT-FREE UNITS

Size Range: 3/4, 1 and 1-1/2 Ton Nominal Cooling and Heating Capacity

Carrier Model Number: **40GXM**

PART 1 – GENERAL

1.01 System Description

Indoor, wall-mounted, direct expansion fan coils are matched with heat pump outdoor units.

1.02 Agency Listings

Unit shall be rated per AHRI Standards 210/240 and listed in the AHRI directory as a matched system.

1.03 Delivery, Storage, And Handling

Units shall be shipped in one piece and shall be stored and handled per manufacturer’s recommendations.

1.04 Warranty (For Inclusion By Specifying Engineer)

PART 2 – PRODUCTS

2.01 Equipment

A. General:

Indoor, direct-expansion, wall-mounted fan coil. Unit shall be complete with cooling/heating coil, fan, fan motor, piping connectors, electrical controls, microprocessor control system, and integral temperature sensing. Unit shall be furnished with integral wall mounting bracket and mounting hardware.

B. Unit Cabinet:

Cabinet discharge and inlet grilles shall be attractively styled, high-impact polystyrene. Cabinet shall be fully insulated for improved thermal acoustic performance.

C. Fans:

1. Fan shall be tangential direct-drive blower type with air intake at the top of the unit and discharge at the bottom front. Automatic, motor-driven vertical air sweep shall be provided standard.
2. Air sweep operation shall be useable selectable. The vertical sweep may be adjusted (using the remote control) and the horizontal air direction maybe be set manually.

D. Coil:

Coil shall be copper tube with aluminum fins and galvanized steel tube sheets. Fins shall be bonded to the tubes by mechanical expansion. A drip pan under the coil shall have a drain connection for hose attachment to remove condensate. Condensate pan shall have internal trap.

E. Motors:

Motors shall be totally enclosed, permanently lubricated ball bearing with inherent overload protection. Fan motors shall be 4-speed.

F. Controls:

Controls shall consist of a microprocessor-based control system which shall control space temperature, determine optimum fan speed, and run self diagnostics. The temperature control range shall be from 62°F to 84°F (16.7°C to 28.9°C).

The unit shall have the following functions as a minimum:

1. Automatic restart after power failure at the same operating conditions as at failure.
2. A timer function to provide a minimum 24-hour timer cycle for system Auto Start/Stop.
3. Temperature sensing control to enter set points and operating conditions.
4. Wireless infrared remote control to enter set points and operating conditions.
5. Automatic air sweep control to provide on or off activation of air sweep louvers.
6. Dehumidification mode shall provide increased latent removal capability by modulating system operation and set point temperature.
7. Fan-only operation to provide room air circulation when no cooling is required.
8. Diagnostics shall provide continuous checks of unit operation and warn of possible malfunctions. Error messages shall be displayed at the unit.
9. Fan speed control shall be user-selectable: high, medium, low or microprocessor controlled automatic operation during all operating modes.
10. Cold blow prevention control to ensure that cold air is not blown into the occupied space after the compressor is de-energized in the heating cycle.

The unit shall be protected against the following:

1. Indoor coil freeze up
2. Indoor coil high temperature protection shall be provided to detect excessive indoor discharge temperature when unit is in heat pump mode.

G. Filters:

Units shall have filter track with factory-supplied cleanable filters.

H. Electrical Requirements:

Indoor fan motor to operate at 208/230 volts. Power is supplied from the indoor unit.

I. Operating Characteristics:

The 40GXM system shall have a minimum listed SEER (seasonal energy efficiency ratio) of up to 14.5 SEER at AHRI conditions, and HSPF of up to 8.4.

J. Refrigerant Lines:

All units should have refrigerant line connections that can be oriented to connect from the left, right, or back of unit. Both refrigerant lines need to be insulated (on heat pump units).

K. Special Features (Field Installed):

1. Condensate Pump: The condensate pump shall remove condensate from the drain pan when gravity drainage cannot be used. Pump shall be designed for quiet operation. Pump shall consist of two parts: an internal reservoir/sensor assembly, and a remote sound-shielded pump assembly. A liquid level sensor in the reservoir shall stop cooling operation if the liquid level in the reservoir is unacceptable.

