

**40QAQ024 with 38QRR018
13 SEER Underceiling System
Performance™ Series Heat Pump
with Puron® Refrigerant**



Turn to the Experts.™

Submittal Data

Job Data: _____ Location: _____
 Buyer: _____ Buyer P.O.# _____ Carrier # _____
 Unit Number: _____ Model Number: _____
 Performance Data Certified By: _____ Date: _____

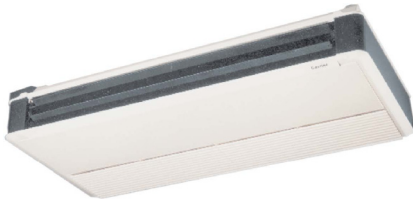

40QAQ



38QRR



FEATURES

- Mounting bracket
- Electro mechanical controls
- Built-in electric heat
- Auto restart after power failure
- User selectable fan speeds plus auto
- Cleanable filters
- Motorized louvers
- Accessory wired user interfaces
- Capable of connecting to an Energy Management system
- Up to 200 ft (61 m) total piping (accessories required)
- Accessory fresh air intake kit
- Low ambient operation down to -20°F (28.9°C) w/accessory
- Accessory condensate pump
- Power ventilation accessory
- Limited Warranty: 1-year parts / 5-year compressor
- Optional extended parts and labor warranty

Indoor Unit - 40QAQ / Outdoor Unit - 38QRR

(Unless otherwise indicated, data applies to both indoor and outdoor models)

SYSTEM SIZE	018
REFRIGERANT	R-410A
PERFORMANCE	
Cooling Nominal Capacity (Btuh)	18,000
Heating Nominal Capacity (Btuh)	18,000
SEER	13
HSPF	7.7
Moisture Removal Rate(Pints/hr)	4
Airflow (Low/Med/High)	320 / 400 / 480
SOUND PRESSURE (dBA)	
Indoor (Low/Med/High)	46.8 / 47.5 / 48.4
Outdoor	57
SOUND POWER (dBA)	
Indoor (Low/Med/High)	57.8 / 58.5 / 59.4
Outdoor	68
PERFORMANCE AT ACTUAL CONDITIONS:	
Attached <input type="checkbox"/>	Not Attached <input type="checkbox"/>

ELECTRICAL

System Voltage	208/230-1-60
MCA	
Indoor	9.29
Outdoor	12.1
MOCP	
Indoor	15
Outdoor	20
Fan Motor (Indoor) (FLA)50
Electric Heat (kW)	2.00

CONTROLS

Control Remote	Wired
Control Voltage	24v
Control Wiring (0-75 ft.)	18 AWG
Control Wiring (75-200 ft.)	16 AWG

REFRIGERANT LINES (Insulate vapor line)

Liquid Line (in.) OD	3/8
Vapor Line (in.) OD	5/8
Metering/Control Device	Accurater at indoor unit

* Refer to NEC and local codes for compliance requirements.

Thermostat Slim Line 7-day Programmable:	Required <input type="checkbox"/>	Not Required <input type="checkbox"/>
Flat Stat 7-day Programmable:	Required <input type="checkbox"/>	Not Required <input type="checkbox"/>
Thermostat Super T2 5-1-1 Commercial:	Required <input type="checkbox"/>	Not Required <input type="checkbox"/>
Remote Room Sensor Kit:	Required <input type="checkbox"/>	Not Required <input type="checkbox"/>
Condensate Pump:	Required <input type="checkbox"/>	Not Required <input type="checkbox"/>

Fresh Air Intake Kit:	Required <input type="checkbox"/>	Not Required <input type="checkbox"/>
Low Ambient Kit:	Required <input type="checkbox"/>	Not Required <input type="checkbox"/>
Isolation Relay:	Required <input type="checkbox"/>	Not Required <input type="checkbox"/>
Crankcase Heater:	Required <input type="checkbox"/>	Not Required <input type="checkbox"/>
Wind Baffle:	Required <input type="checkbox"/>	Not Required <input type="checkbox"/>

UNIT DIMENSIONS – INDOOR MODEL

UNIT SIZE	INDOOR MODEL	WIDTH (IN.) A	HEIGHT (IN.) B	DEPTH (IN.) C	WEIGHT (LB)
24	40QAQ024-3	50-15/16	9-15/16	23-1/8	110

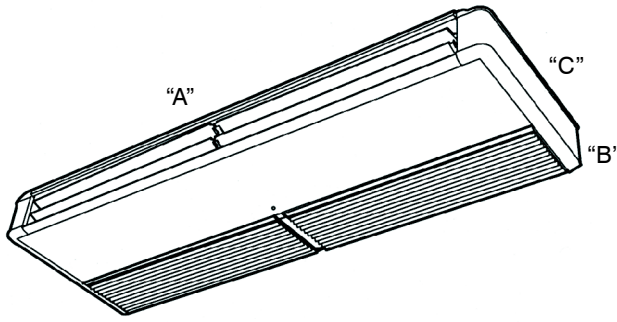

Fig. 1 – 40QAQ Dimensions

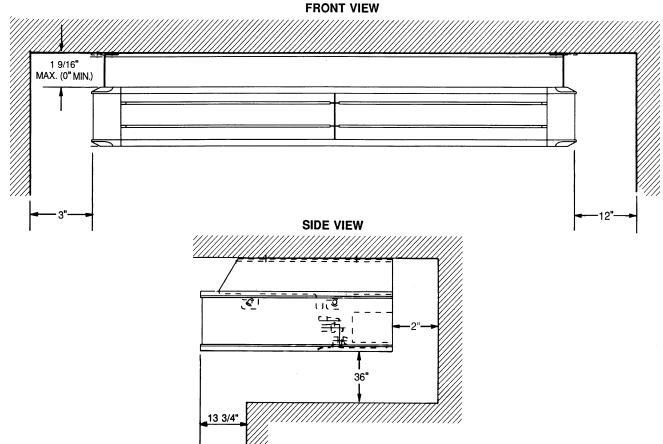
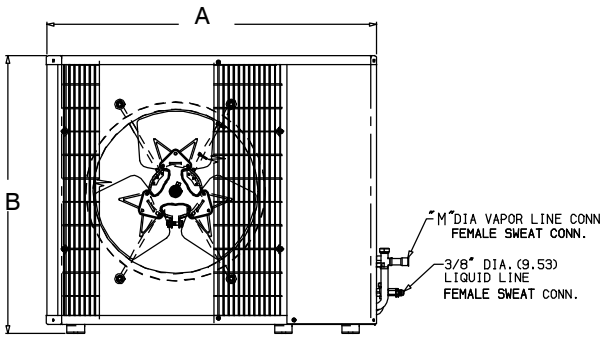
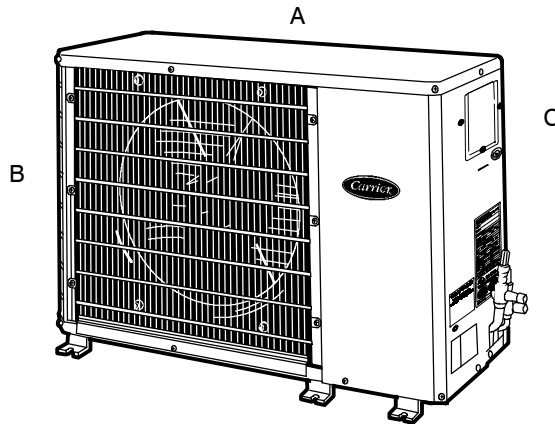

Fig. 2 – 40QAQ Clearance

UNIT DIMENSIONS – OUTDOOR MODEL

UNIT SIZE	OUTDOOR MODEL	WIDTH (IN.) A	HEIGHT (IN.) B	DEPTH (IN.) C	WEIGHT (LB)
18	38QRR018--3	36-15/16	25-1/8	14-9/16	166



FRONT VIEW

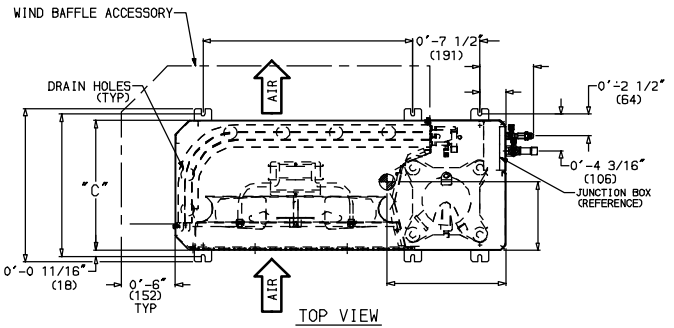

Fig. 3 – 38QRR DIMENSIONS