

CODE NO.



**Carrier**  
A United Technologies Company

THIS DOCUMENT IS THE PROPERTY OF CARRIER CORPORATION AND IS DELIVERED UPON THE EXPRESS CONDITION THAT THE CONTENTS WILL NOT BE DISCLOSED OR USED WITHOUT CARRIER CORPORATION'S WRITTEN CONSENT.

SUBMISSION OF THESE DRAWINGS OR DOCUMENTS DOES NOT CONSTITUTE PART PERFORMANCE OR ACCEPTANCE OF CONTRACT.

**40UH HORIZONTAL UNIT VENTILATOR**  
MODEL 40UHE6  
FRONT DISCHARGE PLENUM  
DOUBLE DEFLECTION GRILLE/DUCT COLLAR

**40UH**  
Design E

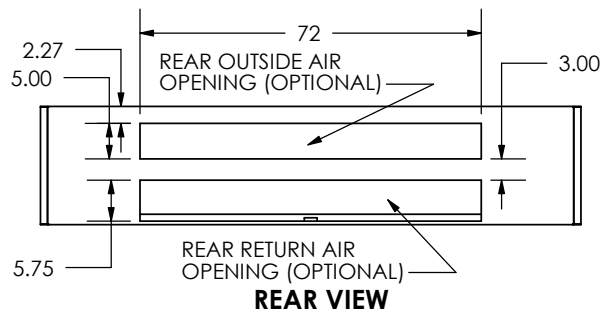
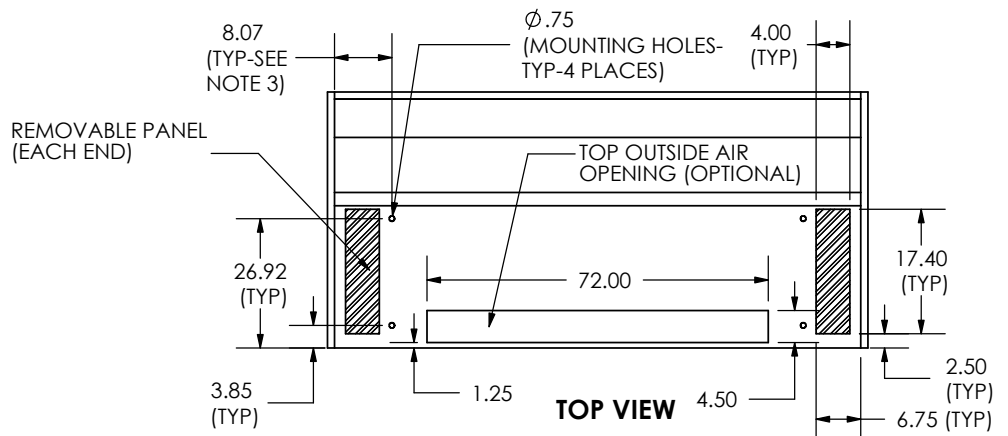
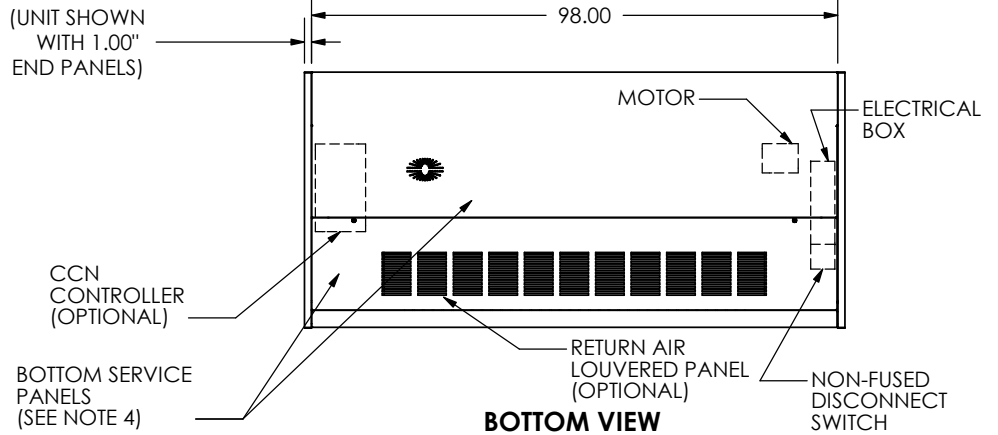
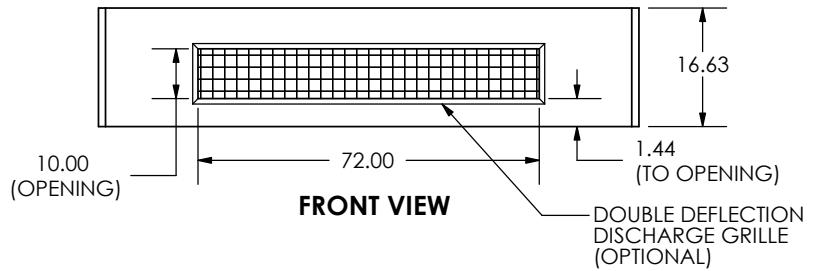
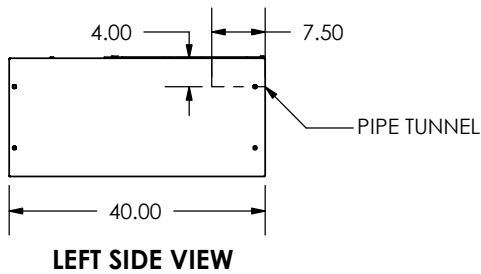

**NOTE:**

1. Drawing refers to Design "E" units.
2. All dimensions are in inches.
3. Dimension does not include end panels.
4. Two bottom panels provided for service access.
5. Motor and electrical power input box on right side of unit. Box includes Fan Speed switch, On/Off switch and non-fused disconnect switch.
6. Connection hand is determined by facing discharge of unit.
7. Approx shipping weight is 1020 lbs. Approx installed weight is 1000 lbs.

PRODUCT INFORMATION IS SUBJECT TO CHANGE WITHOUT NOTICE

2/2/2005

JOB NAME	JOB #	LOCATION	BUYER	BUYER #	DRAWING NO. <b>40UHE-303-1</b>	REV <b>A</b>
----------	-------	----------	-------	---------	--------------------------------	--------------