

LEFT SIDE VIEW

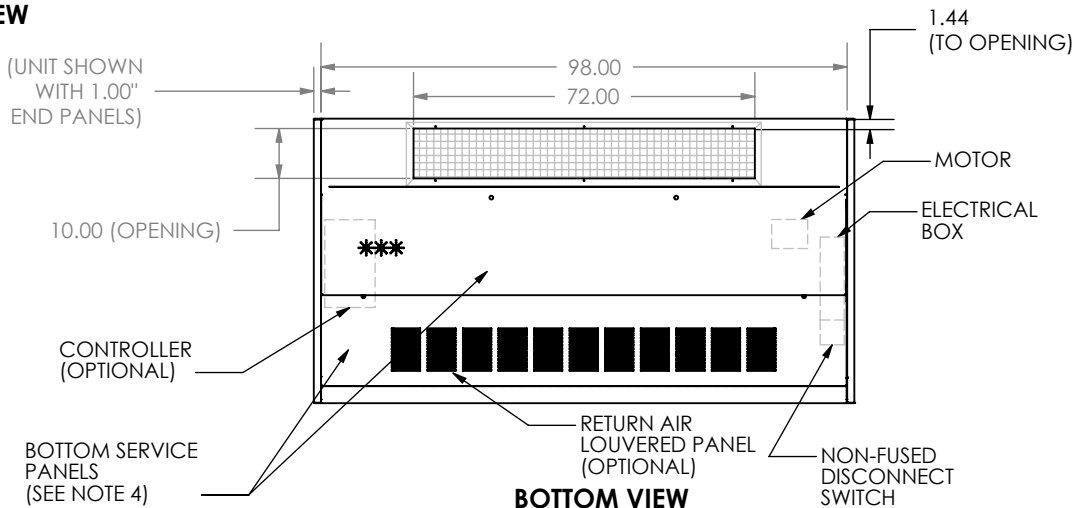

FRONT VIEW



BOTTOM VIEW

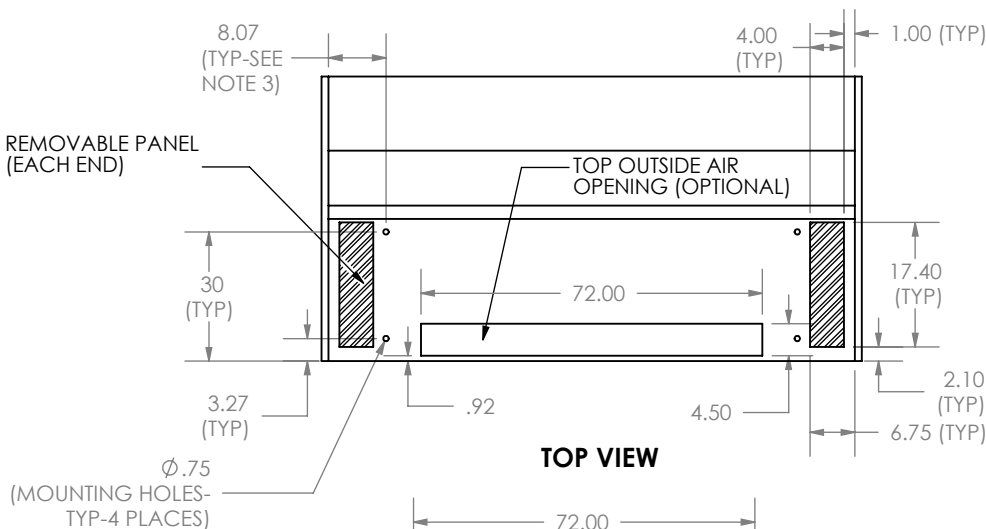

TOP VIEW

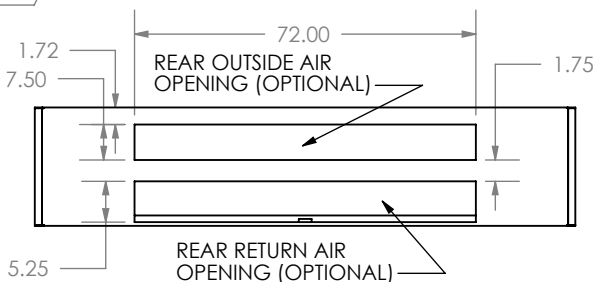

REAR VIEW

NOTE:

1. Drawing refers to Design "F" units.
2. All dimensions are in inches.
3. Dimension does not include end panels.
4. Two bottom panels provided for service access.
5. Motor and electrical power input box on right side of unit. Box includes Fan Speed switch, On/Off switch and non-fused disconnect switch.
6. Connection hand is determined by facing discharge of unit.
7. Approx shipping weight is 1050 lbs. Approx installed weight is 1030 lbs.