

**RIGHT SIDE VIEW**

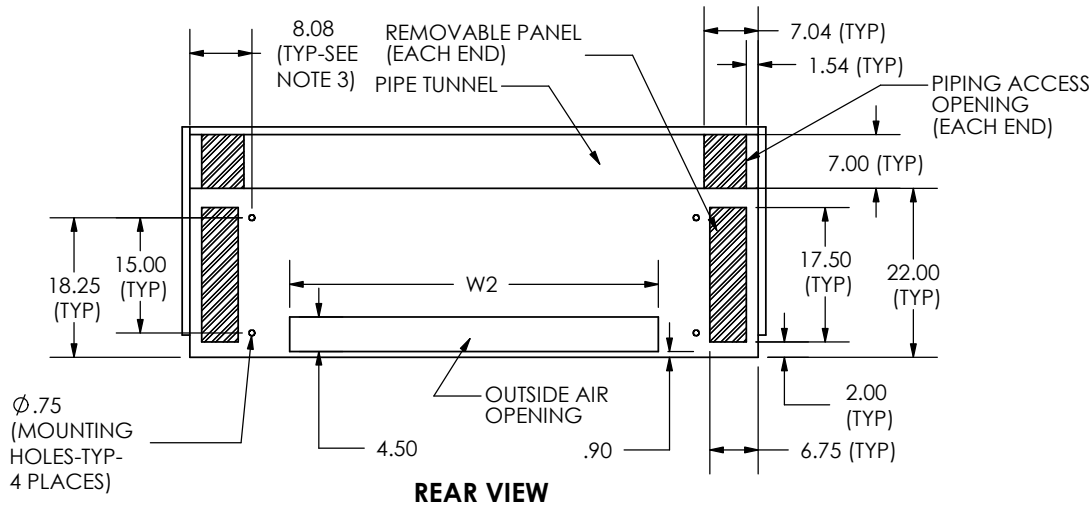

**REAR VIEW**

MODEL NO.	CFM	W1	W2	W3	APPROXIMATE SHIPPING WEIGHT (LBS)	APPROXIMATE INSTALLED WEIGHT (LBS)
40UVE1	500	50	24	16.60	330	315
40UVE2	750	62	36	31.67	400	380
40UVE3	1000	74	48	46.74	480	460
40UVE4	1250	86	60	61.81	590	570
40UVE5	1500	98	72	78.47	660	640

**NOTE:**

1. Drawing refers to Design "E" units.
2. All dimensions in inches.
3. Dimension does not include end panels.
4. Three front panels provided for service access.
5. Motor and electrical power input box on right side of unit. Box includes Fan Speed switch, On/Off switch and non-fused disconnect switch.
6. Connection hand is determined by facing discharge of unit.