



Installation Instructions

PART NO. CRSMKDET001D00, CRSMKSUP001B00, CRSMKSEN001A00

TABLE OF CONTENTS

GENERAL	1
SAFETY CONSIDERATIONS	1
INSTALLATION	2
Check Package Contents	2
Return Air Smoke Detector Installation	2
Supply Air Smoke Detector Installation	5
Sensor Installation	7
Configuring the <i>ComfortLink</i> ™ Controller	8
OPERATION	8
MAINTENANCE	9
Cleaning Procedure	9
Recommended Service Schedule	9
Sensor Tests	9
Controller Tests	9
TROUBLESHOOTING	10
Dirty LED	10
Power LED	10
Trouble LED	10

IMPORTANT: There are two different design revision 48/50HG units that have been produced. Because of these differences, there are two different versions of this accessory. This accessory literature covers accessories manufactured for units with design revision 1. This revision designator is found in the 13th digit of the unit model number located on the units' rating plate. Design revision 0 units are not covered in this accessory book. To determine the design revision, refer to the full unit model number. See Fig. 1 for an example of an HG model number. The design revision number in the model number nomenclature is located in position 13.

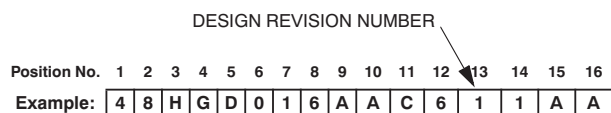

Fig. 1 – Model Number Chart

C07172

GENERAL

An HVAC (heating, ventilation and air-conditioning) system supplies conditioned air to virtually every area of a building. Smoke introduced into this air duct system will be distributed throughout the entire building. Smoke detectors designed for use inside the unit are used to sense the presence of smoke passing through the unit.

The smoke detector utilizes photoelectric technology for the detection of smoke. This detection method, when combined with an efficient ducting design, samples air passing through the unit. If sufficient smoke is sensed, an alarm signal is initiated and the *ComfortLink* controls will shut down the unit. With the unit shut down, the unit will not blow toxic smoke and fire gases throughout the areas served by the duct system.

The return air smoke detector is part number CRSMKDET001D00, which includes a Smoke Sensor and a Smoke Control Module combined with sampling tube, harnesses and hardware. The supply air smoke detector is part number CRSMKSUP001B00, which includes a Smoke Sensor and a Smoke Control Module combined with sampling tube, harnesses and hardware. Part number CRSMKSEN001A00 is a Smoke Sensor only for use as a second (Supply with existing Return, or Return with existing Supply) Air Smoke Detector with sampling tube, harnesses and hardware.

The Control Module can be attached to a Smoke Sensor and installed as an assembled unit, or it can be installed separate from a sensor. One Controller can be used to control up to two detectors (Smoke Sensors).

SAFETY CONSIDERATIONS

Installation and servicing of air-conditioning equipment can be hazardous due to system pressure and electrical components. Only trained and qualified service personnel should install, repair, or service air-conditioning equipment.

Untrained personnel can perform the basic maintenance functions of cleaning coils and filters and replacing filters. All other operations should be performed by trained service personnel. When working on air-conditioning equipment, observe precautions in the literature, tags and labels attached to the unit, and other safety precautions that may apply.

Follow all safety codes. Wear safety glasses and work gloves. Use care when handling and installing the accessory.

Recognize safety information. This is the safety-alert symbol . When you see this symbol on the unit and in instructions or manuals, be alert to the potential for personal injury.

Understand the signal words DANGER, WARNING, and CAUTION. These words are used with the safety-alert symbol. DANGER identifies the most serious hazards which **will** result in severe personal injury or death. WARNING signifies a hazard which **could** result in personal injury or death. CAUTION is used to identify unsafe practices which **may** result in minor personal injury or product and property damage. NOTE is used to highlight suggestions which **will** result in enhanced installation, reliability, or operation.

CRSMK

⚠ WARNING

ELECTRICAL SHOCK HAZARD

Failure to follow this warning could cause personal injury, death and/or equipment damage.

Disconnect all power to the unit before performing maintenance or service. Install Lock Out tags on disconnects or breakers.

⚠ WARNING

FIRE HAZARD

Failure to follow this warning could cause personal injury and/or death.

The National Fire Protection Association has established that DUCT DETECTORS MUST NOT BE USED AS A SUBSTITUTE FOR OPEN AREA DETECTOR PROTECTION as a means of providing life safety. Nor are they a substitute for early warning in a building's regular fire detection system. Carrier supports this position and strongly recommends that the user read NFPA Standards 90A, 72, and 101. This smoke detector is listed per UL 268A.

⚠ WARNING

ELECTRICAL SHOCK AND FIRE HAZARD

Failure to follow this warning could cause personal injury.

This device will not operate without electrical power. Fire situations may cause an interruption of power. The system safeguards should be discussed with your local fire protection specialist.

⚠ WARNING

FIRE HAZARD

Failure to follow this warning could cause personal injury and/or equipment damage.

This device will not sense smoke unless the ventilation system is operating and the cover is installed.

⚠ WARNING

ELECTRICAL SHOCK HAZARD

Failure to follow this warning could cause personal injury and/or equipment damage.

For this detector to function properly, it **MUST** be installed according to the instructions in this manual. The detector **MUST** be operated within ALL electrical and environmental specifications listed in this manual. Failure to comply with these requirements may prevent the detector from activating when smoke is present in the air duct.

INSTALLATION

⚠ CAUTION

EQUIPMENT DAMAGE HAZARD

Failure to follow this caution may result in equipment damage.

When installing the smoke detector in the unit, follow all local codes.

Check Package Contents

Remove accessory packaging and inspect shipment for damage. If any damage is found, file a claim with the shipping agent immediately. If any item is missing or any part does not assemble properly, notify the Carrier distributor.

Table 1 lists the accessory package contents. Fig. 2 shows the smoke detector.

Return Air Smoke Detector Installation (CRSMKDET001D00)

The return air smoke detector is to be installed in the predrilled holes located above compressor B1/A2 in the electrical/compressor section. (See Fig. 3.)

Table 1—Accessory Package Contents — Return Air Smoke Detector (CRSMKDET001D00), Supply Air Smoke Detector (CRSMKSUP001B00), Sensor (CRSMKSEN001A00)

UNIT	RETURN SMOKE DETECTOR CRSMKDET001D00			SUPPLY SMOKE DETECTOR CRSMKSUP001B00			ADDITIONAL SENSOR CRSMKSEN001A00		
	Description	Part Number	Quantity	Description	Part Number	Quantity	Description	Part Number	Quantity
48/50HG014-028, 48/50PG20-28	Sensor/Controller/ Harness/Tube	HK61ZT001	1	Controller/ RJ-45 Harness	HK28ZT001	1	Sensor Module	HK50ZT001	1
	Screw	AL56AU168	2	Screw	AL56AU168	5	Screw	AL56AU168	1
	Screw	AL48AM397	2	Sensor Module	HK50ZT001	1	Screw	AL48AM397	2
	Bracket	50TG501113	1	Tube	RN20ZT008	1	Bracket	50TG501113	1
	Large Bushing	HY93NH085	1	Cable Assy	RM91ZT015	1	Large Bushing	HY93NH085	1
	Sampling Tube	RN20ZT060	1	Plug	—	1	Sampling Tube	RN20ZT060	1
	Plug	—	1	Rubber Gasket	—	2	Plug	—	1
	Rubber Gasket	—	2	Sampling Tube Collar	—	1	Rubber Gasket	—	2
	Sampling Tube Collar	—	1	Snap-in Wire Tie	HY76TB110	2	Sampling Tube Collar	—	1
	Wire Tie	HY76TB125	1	Wire Tie	HY76TB125	2	Tube	RN20ZT008	1
	Bushing	HY93NH069	1	Bushing	HY93NH069	1	Cable Assy	RM91ZT015	1
	Harness Assy	50TG403507	1	Harness Assy	50TG403507	1	Snap-in Wire Tie	HY76TB110	5
	Exhaust Tube	—	1	Exhaust Tube	—	1	Wire Tie	HY76TB125	1
							Cable Assy	RM91ZT001	1
							Exhaust Tube	—	1

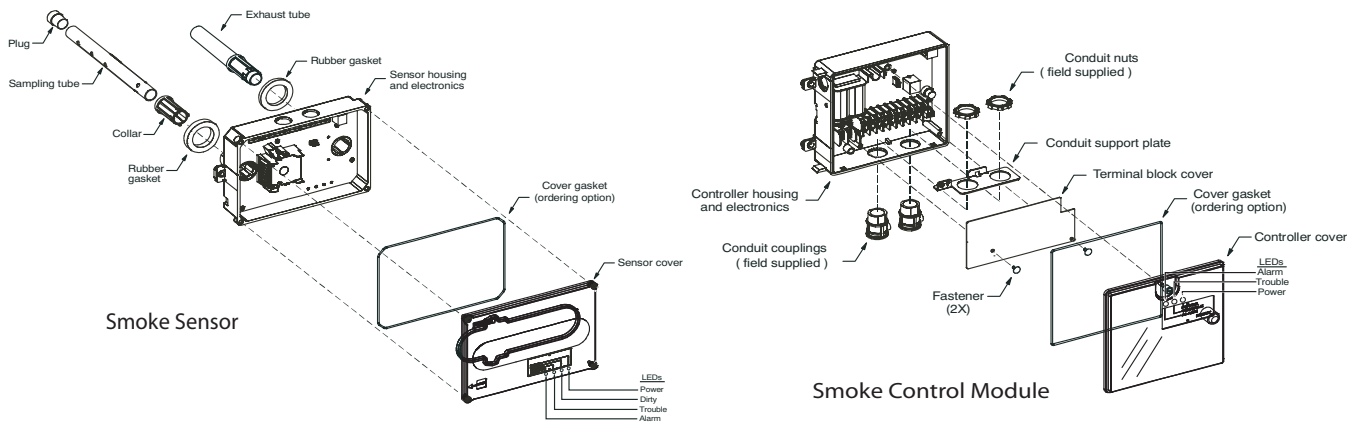

Fig. 2 – Smoke Detector

C07173

CRSMK

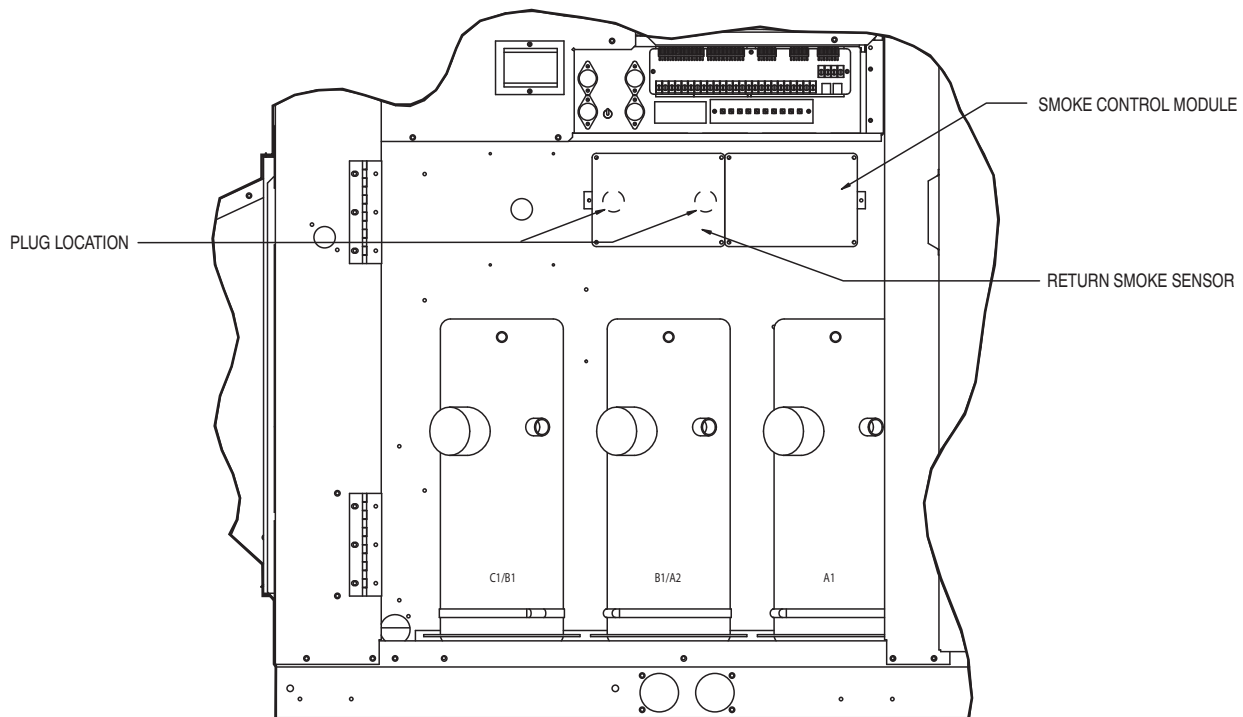

Fig. 3 – Return Air Smoke Detector Location

C07174

⚠ WARNING

ELECTRICAL SHOCK HAZARD

Failure to follow this warning could result in personal injury and/or death.

Prior to installation of this accessory, make sure all power is disconnected to the unit and locked out and tagged.

NOTE: For horizontal applications it is easiest to install the smoke detector prior to making duct connections.

1. Open the hinged electrical/compressor access door and secure.
2. Find the 2 plugs located above compressor B1/A2, remove and discard. Cut holes in the insulation located behind the partition.

3. Remove cover from smoke detector. The screws will remain captured in the cover.
4. Slide exhaust tube into the sensor. The exhaust tube should be inserted from the back of the sensor, into the hole with four slots, and locked into place. (See Fig. 2.)
5. Slide smoke detector into holes in partition with the terminal block to the right. Do not secure at this time.
6. Slide the sampling tube collar over the sampling tube until the tabs lock into the tube. (See Fig. 2.)
7. Slide long sampling tube (P/N RN20ZT060) into left-hand hole of smoke detector. It might be necessary to tilt the smoke detector upwards in order to properly align the sampling tube, **making sure that the sampling holes point DOWN.** (See Fig. 4.)
8. Install plug into far end of sampling tube.
9. Remove the unit side panel at the return end of the unit. Save screws for use later.

10. Mount the sampling tube support bracket to the cross member with two 1/4AB-14 5/8-in. screws (P/N AL48AM307) as shown in Fig. 5. Insert large snap bushing (P/N HY93NH085) into hole in bracket.
11. Slide sampling tube into bracket. (See Fig. 4.) Pull the sampling tube so that the locking collar snaps into the smoke detector.
12. Attach smoke detector to partition using two, 8-18 3/4-in. pan head screws (P/N AL56AU168).

⚠ CAUTION

EQUIPMENT DAMAGE HAZARD

Failure to follow this caution may result in equipment damage.

Do not overtighten the screws.

13. Replace the unit side panel.
14. Install the snap bushing (P/N HY93NH069) in the center knockout underneath the control terminal strips located in the bottom right-hand corner of the control box.
15. Feed wires through snap bushing and connect to appropriate terminals as shown in Fig. 6 for *ComfortLink*™ units or Fig. 7 for Electro-Mechanical units.

NOTE: This step is not needed with 48/50PG Humidi-MiZer™ units because they have plug 19 harness already installed in the control box. The harness assembly part number 50TG403507 that came with the accessory is not used. Factory installed PL-19 can be located outside the control box by its appropriate label. For Humidi-MiZer smoke detector wiring refer to Fig. 8.

16. Connect PL-19 from the smoke detector control module to the PL-19 on the control box harness installed in Step 15.

NOTE: On 48PG Humidi-MiZer units the control box harness has a jumper plug attached. This needs to be disconnected so PL-19 from the smoke detector can be snapped in.

17. Restore power to the unit.
18. Configure *ComfortLink* controller as specified in *Configuring the ComfortLink Controller*.
19. Perform Sensor and Controller tests. At a minimum, the Magnet test should be performed to verify smoke detector wiring.
20. Replace smoke detector cover.
21. Check for alarms. Correct any problems.

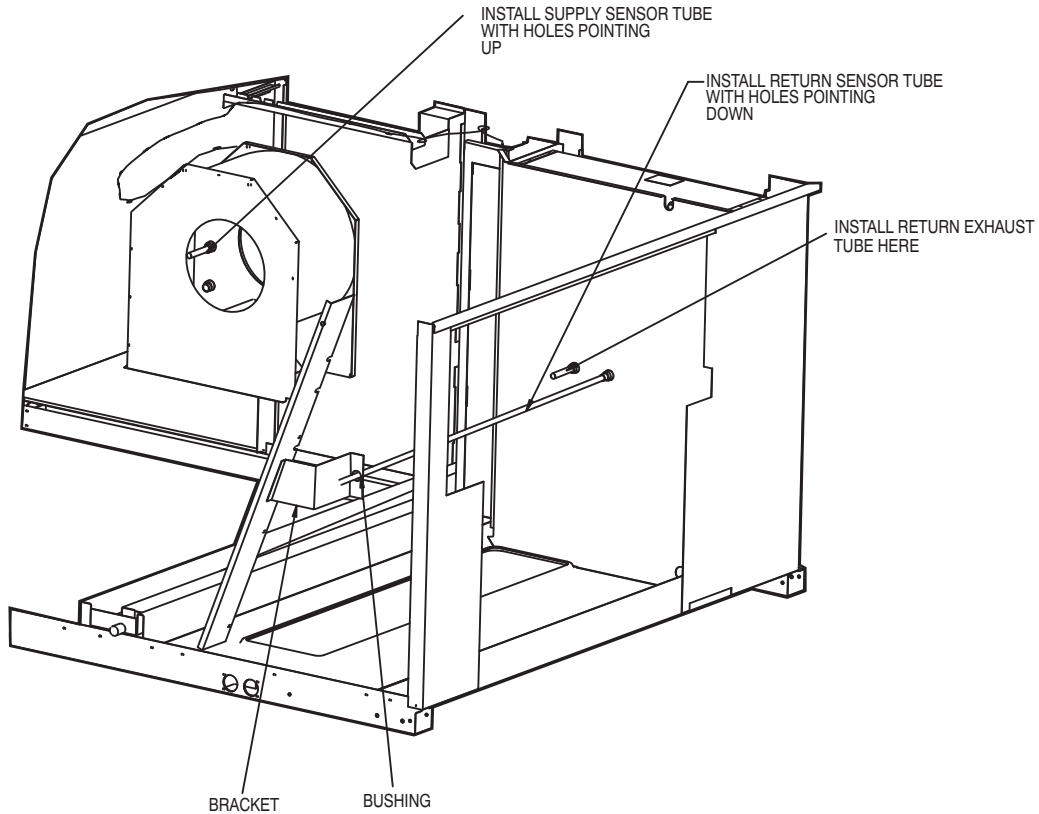

Fig. 4 – Supply and Return Sensor Tube

C07175

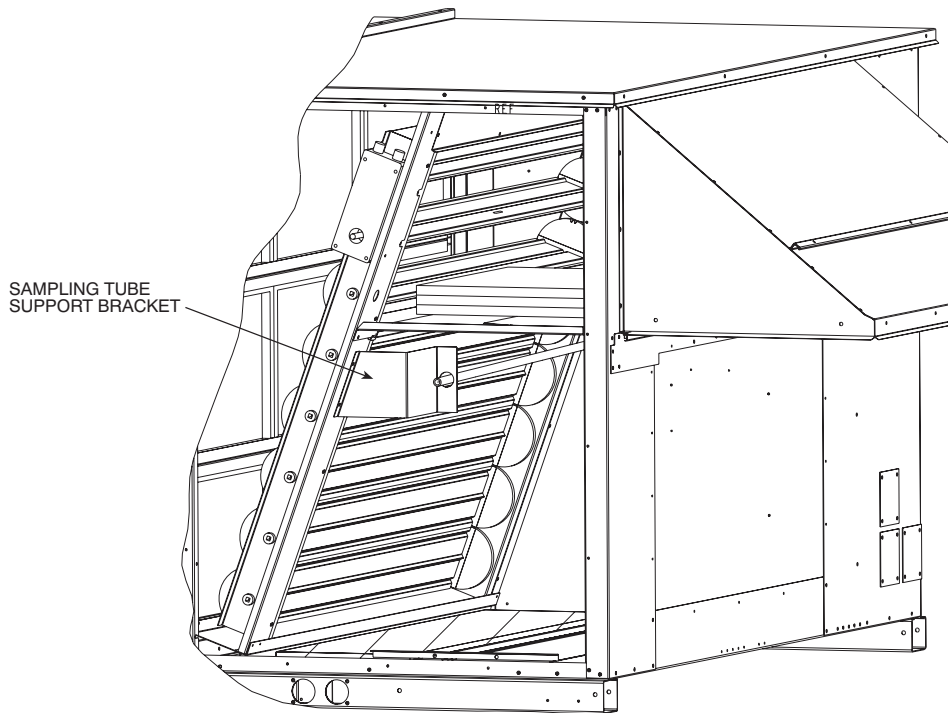

Fig. 5 – Sampling Tube Support Bracket

C07176

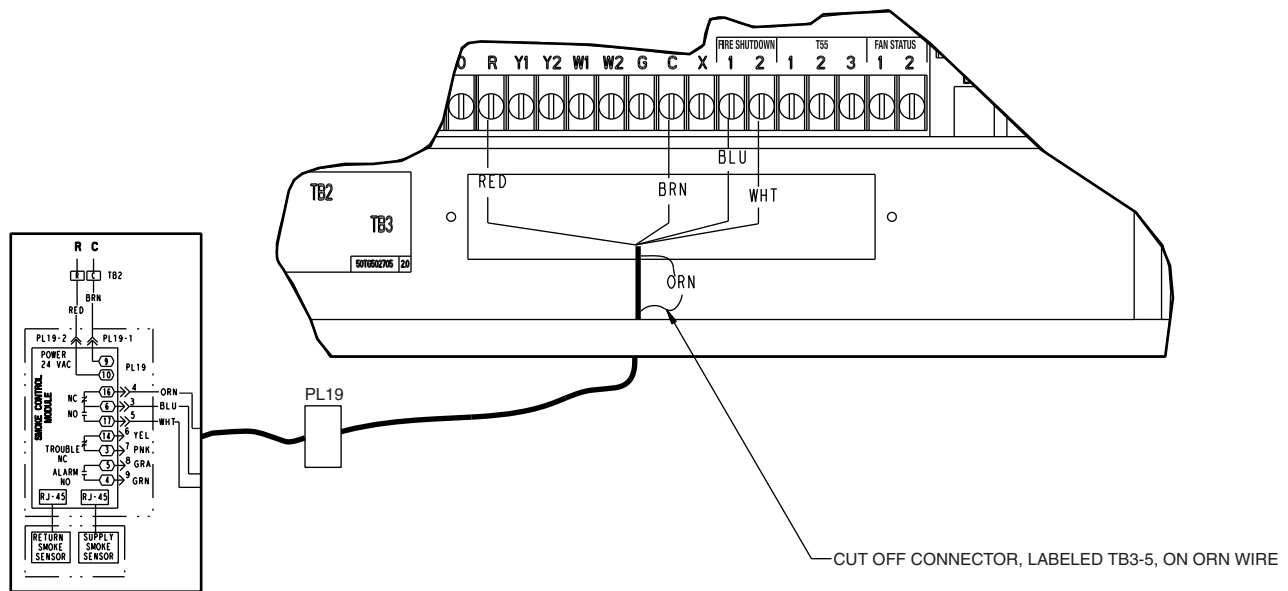

Fig. 6 – Return and Supply Air Smoke Detector Wiring on ComfortLink Units

C07177

Supply Air Smoke Detector Installation (CRSMKSUP001D00)

The supply air smoke detector is to be installed in the predrilled holes located on the front of the first indoor blower. (See Fig. 9.)

⚠ WARNING

ELECTRICAL SHOCK HAZARD

Failure to follow this warning could result in personal injury and/or death.

Prior to installation of this accessory, make sure all power is disconnected to the unit and locked out and tagged.

1. Open the indoor fan access door and secure.
2. Open and secure hinged electrical/compressor access door.
3. Disconnect wires located on the right-hand side of the fan deck. On gas heat units, the indoor fan plug and the limit switch quick connects must be disconnected. On units without gas heat, only the indoor fan plug must be disconnected.
4. Find the 2 plugs located in the blower side plate. Remove the plugs and discard. It will be necessary to remove some of the tape holding the plugs in place.
5. Remove cover from smoke detector. The screws will remain captured in the cover.

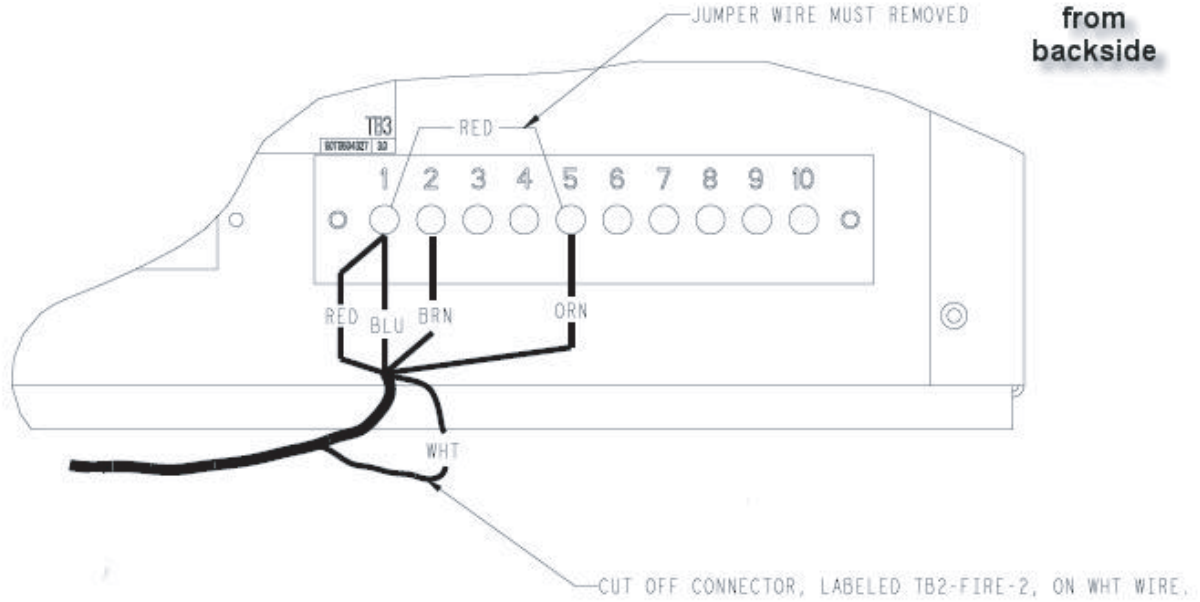

Fig. 7 – Smoke Detector Wiring on Electro-Mechanical Control Units

C07178

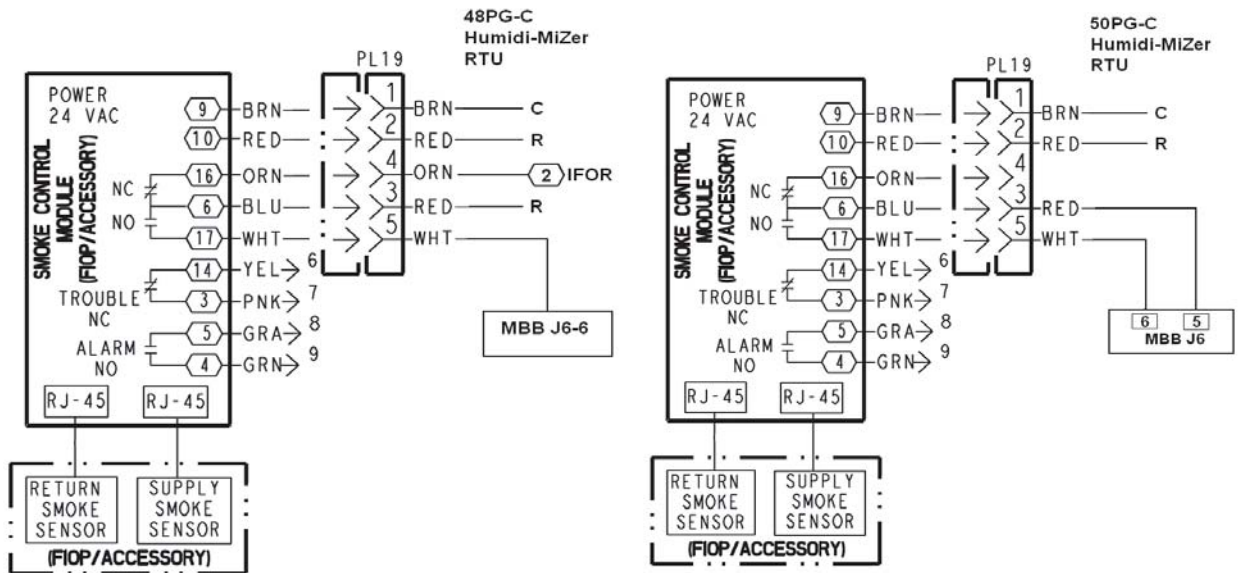

Fig. 8 – 48/50PG Humidi-MiZer™ Smoke Detector Wiring

C07179

6. Slide the sampling tube collar over the sampling tube until the tabs lock into the tube.
7. Slide sampling tube into smoke detector with eight slots. **Make sure sampling tube holes are aligned facing UP.**
8. Insert plug into far end of the sampling tube.
9. Place rubber gaskets over each sampling tube on smoke detector. (See Fig. 2.)
10. Remove one knockout from top of smoke detector.
11. Insert one end of RJ-45 wire harness through knockout and wire to smoke detector as shown in Fig. 10.
12. Slide smoke detector into holes in fan side plate with the terminal block at the top and secure using two, 8-18 ³/₄-in. pan head screws (P/N AL56AU168). Replace cover.

CAUTION

EQUIPMENT DAMAGE HAZARD

Failure to follow this caution may result in equipment damage.

Do not overtighten the screws.

13. Attach cable to fan side plate using snap-in wire ties. See Fig. 9 for clarification. Secure to center post.
14. Secure cable to back side of cable tray using three snap-in wire ties.
15. In the Electrical/Compressor section, install snap bushing in the center knockout underneath the terminal strips located in the bottom right-hand corner of control box.
16. Connect wires to terminal strips as shown in Fig. 6 for *ComfortLink*™ units or Fig. 7 for Electro-Mechanical Units.

NOTE: This step is not needed with 48/50PG Humidi-MiZer™ units because they have plug 19 harness already installed in the control box. The harness assembly part number 50TG403507 that came with the accessory is not used. Factory installed PL-19 can be located outside the control box by its appropriate label. For Humidi-MiZer smoke detector wiring refer to Fig. 8.

17. Remove cover from control module and remove knockout from side of module nearest the RJ-45 connector.
18. Using three 8-18 ³/₄-in. pan head screws (P/N AL56AU168) screws, secure control module to compressor partition above compressor B1/A2 location.
19. Connect PL-19 from control module to PL-19 from wiring harness installed in Step 16.

NOTE: On 48PG Humidi-MiZer units, the control box harness has a jumper plug attached. This needs to be disconnected so PL-19 from the smoke detector can be snapped in.

20. Route cable from supply smoke sensor, along the outside of the control box, through the control module knockout and connect to the J1 RJ-45 connector.
21. Using wire ties, secure the wiring so it does not interfere with unit operation.
22. Replace control module cover.
23. Restore power to the unit.
24. Configure *ComfortLink* controller as specified in Configuring the *ComfortLink* Controller below.
25. Perform Sensor and Controller tests. At a minimum, the Magnet test should be performed to verify smoke detector wiring.
26. Turn off power to the unit.
27. Reconnect the indoor fan plug and the limit switch wires if applicable.
28. Close the indoor fan section door.
29. Restore power to the unit and check for alarms. Correct any problems encountered.
30. Close Electrical/Compressor section door.

Sensor Installation (CRSMKSEN001A00)

When adding return smoke sensor to previously installed supply smoke detector:

1. Open electrical/compressor section access door/panel.
2. Disconnect PL-19 from control module to terminal strip by separating plug connectors.
3. Remove control module cover. Disconnect supply sensor RJ-45 wire from control module.
4. Remove three screws attaching control module to compressor partition and save screws for later use.
5. Remove control module from unit.
6. Slide feet of control module into receptacle on the return sensor housing and secure from the backside using one screw removed in Step 4. The J1 RJ-45 connector on sensor should be nearest the control module. Knockout holes should align. (See Fig. 11.)
7. Route short RJ-45 wire from J1 connector of sensor, through knockout holes, and connect to J1 connector of control module.
8. Follow steps 2-20 of instructions for installing return smoke detector.

IMPORTANT: Step 15 requires connecting the supply smoke sensor RJ-45 wire to connector J2 in the control module.

When adding supply smoke sensor to previously installed return smoke detector:

Follow steps 1-14 and 19-29 from supply smoke detector installation instructions.

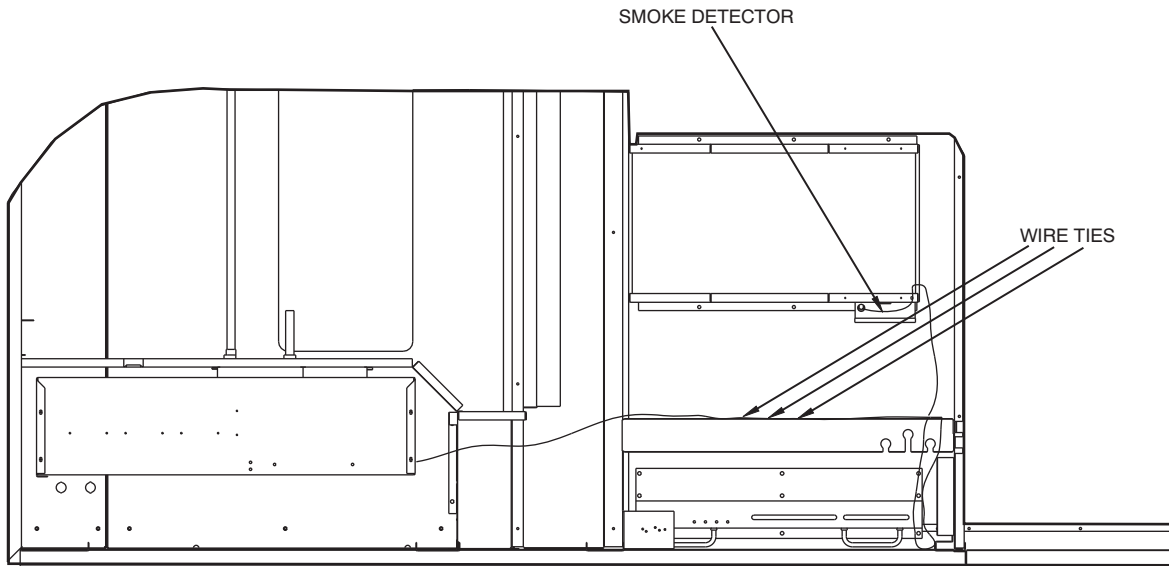

Fig. 9 – Supply Smoke Detector Location and Wire Routing (Top View)

C07180

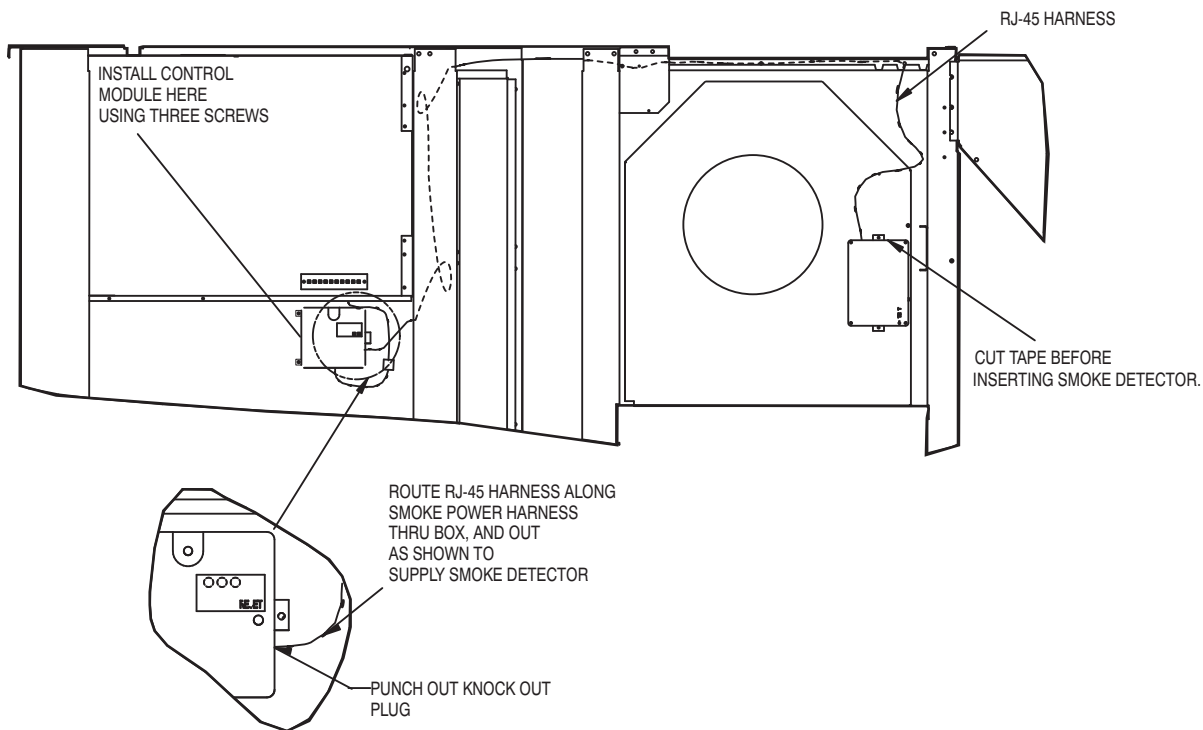



Fig. 10 – Supply Control Module Installation (Side View)

C07181

Configuring the ComfortLink™ Controller

Configuration settings for the ComfortLink controller are changed by using the Scrolling Marquee display. A password may be required to edit the configurations, depending on the previous settings configured in the unit. Default password is “1111.” Use the arrow keys to scroll the red LED on the display to the “Configuration” position and press **ENTER**. Scroll through the menu until UNIT is found and press **ENTER**. After reaching the UNIT sub-menu, scroll to FS.SW (Fire Shutdown Input) and press **ENTER** twice, change the value to 1 (Normal Open) with the arrow keys, press **ENTER** again. Press **ESCAPE** three times to return to the top level of the menu. Additional information about changing configurations can be found in the Control and Troubleshooting Guide for 48/50HG and 48/50PG units.

OPERATION

 CAUTION
<p>EQUIPMENT DAMAGE HAZARD</p> <p>Failure to follow this caution may result in damage to the unit.</p> <p>The smoke detector must be tested and maintained regularly following NFPA 72 requirements. The smoke detector should be cleaned at least once a year.</p>

The smoke detector contains a photoelectric detector approved for an extended air speed range of **100 to 4000 feet per minute** and an operational temperature range of -4° to 158°F . Do not operate the smoke detector out of these ranges.

The smoke detector operates on 24 vac, 120 vac, or 220/240 vac. The thermostat power terminals on the unit are used to power the smoke detector.

The cover of the controller contains the Alarm, Trouble, Dirty and Power LEDs. The cover of the sensor contains the Alarm, Trouble and Power LEDs. (See Fig 2.)

The smoke detector can be reset by a momentary power interruption, by the reset button on the front cover, by the control panel, or by the remote reset accessory.

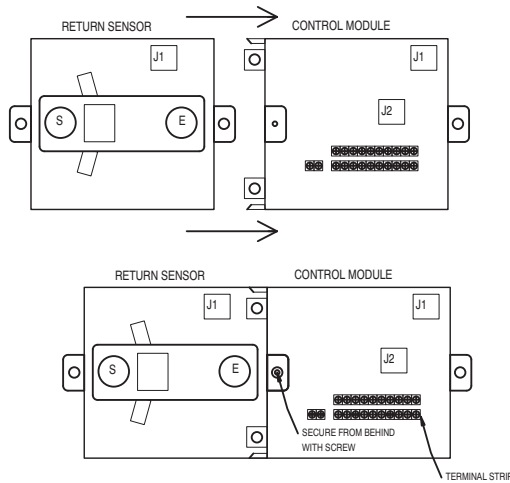

Fig. 11 – Sensor Installation

C07182

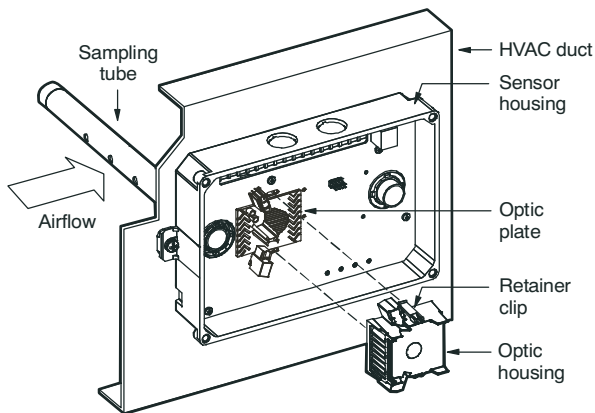

Fig. 12 – Sensor Cleaning Diagram

C07183

MAINTENANCE

IMPORTANT: Notify the proper authorities that the smoke detector system is undergoing maintenance, and that the system will temporarily be out of service. Disable the zone or system undergoing maintenance to prevent unwanted alarms and possible dispatch of the fire department.

Cleaning Procedure

1. Disconnect power from the duct detector then remove the sensor's cover.
2. Using a vacuum cleaner, clean compressed air, or a soft bristle brush, remove loose dirt and debris from inside the sensor housing and cover. (See Fig 12.) Use isopropyl alcohol and a lint-free cloth to remove dirt and other contaminants from the gasket on the sensor's cover.

3. Squeeze the retainer clips on both sides of the optic housing then lift the housing away from the printed circuit board.
4. Gently remove dirt and debris from around the optic plate and inside the optic housing.
5. Replace the optic housing and sensor cover.
6. Connect power to the duct detector then perform a sensor alarm test.

Recommended Service Schedule

- Visually inspect each sensor connected to the controller upon installation and once every 6 months thereafter.
- Perform a sensor alarm test on each sensor connected to the controller upon installation and once every 12 months thereafter.
- Perform a sensor dirty test upon installation and once every 6 months thereafter or more frequently, as conditions warrant.

Sensor Tests

Sensor Alarm Test

The sensor alarm test checks a sensor's ability to signal an alarm state. This test requires the use of a SD-MAG test magnet.

IMPORTANT: This test places the duct detector into the alarm state. Unless part of the test, disconnect all auxiliary equipment from the controller before performing the test. If duct detector is connected to a fire alarm system, notify the proper authorities before performing the test.

To perform a sensor alarm test:

1. Hold the test magnet where indicated on the side of the sensor housing for seven seconds. Verify that the sensor's Alarm LED turns on.
2. Reset the sensor by holding the test magnet against the sensor housing for two seconds. Verify that the sensor's Alarm LED turns off.

Sensor Dirty Test

The sensor dirty test provides an indication of the sensor's ability to compensate for gradual environmental changes. A sensor that can no longer compensate for environmental changes is considered 100% dirty and requires cleaning or replacing. This test requires the use of a SD-MAG test magnet.

To perform a sensor dirty test, hold the test magnet where indicated on the side of the sensor housing for seven seconds. Verify that the sensor's Dirty LED flashes.

IMPORTANT: Holding the test magnet against the sensor housing for longer than 7 seconds will put the duct detector into the alarm state and activate all automatic alarm responses.

The sensor's Dirty LED indicates the results of the dirty test as shown below.

FLASHES	DESCRIPTION
1	0 to 25% dirty. This is typical on a newly installed duct detector.
2	26 to 50% dirty
3	51 to 75% dirty
4	76 to 99% dirty

Controller Tests

Controller Alarm Test

The controller alarm test checks the controller's ability to initiate and indicate an alarm state.

IMPORTANT: This test places the duct detector into the alarm state. Unless part of the test, disconnect all auxiliary equipment from the controller before performing the test. If duct detector is connected to a fire alarm system, notify the proper authorities before performing the test.

To perform a controller alarm test:

1. Press the controller's test/reset switch for seven seconds. Verify that the controller's Alarm LED turns on.
2. After performing a controller alarm test, reset the sensor by pressing the test/reset switch for two seconds. Verify that the controller's Alarm LED turns off.

Controller Dirty Test

The controller dirty test checks the controller's ability to initiate a sensor dirty test and indicate its results.

To perform a sensor dirty test, press the controller's test/reset switch for two seconds. Verify that the controller's Trouble LED flashes.

TROUBLESHOOTING

Dirty LED

Sensor's Dirty LED is Flashing

Clean the sensor assembly as described in Cleaning Procedure.

Power LED

Sensor's Power LED is OFF

1. Check the controller's Power LED. If it is off, determine why the controller does not have power and make the necessary repairs.
2. Check the wiring between the sensor and the controller. If wiring is loose or missing, repair or replace as required.

Controller's Power LED is OFF

1. Make sure the circuit supplying power to the controller is operational. If not, make sure JP2 and JP3 are set correctly on the controller before applying power.

2. Verify that power is applied to the controller's supply input terminals. If power is not present, replace or repair wiring as required.

Trouble LED

Controller's Trouble LED is On

1. Check the Trouble LED on each sensor connected to the controller. If a sensor's Trouble LED is on, determine the cause and make the necessary repairs.
2. Check the wiring between the sensor and the controller. If wiring is loose or missing, repair or replace as required.

Controller's Trouble LED is Flashing

1. One or both of the sensors is 100% dirty. Determine which sensor's Dirty LED is flashing.
2. Clean the sensor assembly as described in Cleaning Procedure.

Sensor's Trouble LED is On

1. Check the sensor's Dirty LED. If it is flashing, the sensor is dirty and must be cleaned.
2. Check the sensor's cover. If it is loose or missing, secure the cover to the sensor housing.
3. Replace sensor assembly.

Sensor's Trouble LED is On But Controller's Trouble LED is Off

Remove JP1 on the controller.