

# Large Rooftop Units 12 to 25 Tons Accessory Motormaster® I Head Pressure Control Kit

Cancels: New

IHK 542J-150-22  
9/15/02

## Installation Instructions

Part Numbers: CRLOWAMB007A00 to 012A00

### CONTENTS

	Page
<b>SAFETY CONSIDERATIONS</b> .....	2
<b>GENERAL</b> .....	2
<b>BEFORE INSTALLING</b> .....	2
<b>INSTALLATION</b> .....	2-11
<b>Step 1 — Install Wind Baffles</b> .....	2
<b>Step 2 — Mount Motormaster I Control</b> .....	2
<b>Step 3 — Mount Sensor Assembly</b> .....	11

### Package Contents\*

ITEM	QTY
Motormaster I Control	1
Outdoor Fan Motor†	1
Transformer†	1
Wiring Harness	1 or 2**
Snap Bushing	1
Heater Contactor††	1
Mounting Bracket	1
No. 10 Sheet Metal Screw	4
Star Lockwasher	4
3/4-in. Lg, 4-40 Screw	2
Plate Washer	2
4-40 Nut	2
Wirenut	2
Sensor Assembly	1

\*This installation instruction is intended for use ONLY ON units with 3 or 6 condenser fans. Part numbers CRLOWAMB010A00, 011A00, and 012A00 contain 2 sets of motors, controllers, sensors, and brackets.

†460-v and 575-v Motormaster I Accessories only.

\*\*Quantity and type depend on which kit is ordered.

††Only used on 460-v and 575-v heat pump units.

#### NOTES:

1. On 460-v and 575-v units, the no. 1 (and no. 4 on 25 ton units) outdoor-fan motor must be replaced with the supplied 208/230-v motor (part no. HC44GE208 on all units except 25 ton units, part no. HC44GE209 [quantity 2] on 25 ton units). A supplied single-phase transformer (part no. HT01AH859 for 575-v units or part no. HT01AH851 on 460-v units) is also required.
2. The Motormaster I control is rated at 8 amps.

### Product Usage

UNIT	UNIT VOLTAGE	PART NUMBER	OPERATING TEMPERATURE LIMIT
12 and 15 Ton, High Tier Units (48/50HJ015,017 and 551A/581A155,180)	460	CRLOWAMB007A00	-20 F (-29 C)
	208/230	CRLOWAMB008A00	
	575	CRLOWAMB009A00	
12 and 15 Ton, Heat Pump Units (50HJQ014,016 and 542J150,180)	460	CRLOWAMB007A00	
	208/230	CRLOWAMB008A00	
	575	CRLOWAMB009A00	
15 and 17.5 Ton, Standard Tier ASHRAE 90.1 Compliant Units (48/50TM016,020 and 558F/580F180,210)	460	CRLOWAMB007A00	
	208/230	CRLOWAMB008A00	
	575	CRLOWAMB009A00	
25 Ton, Standard Tier ASHRAE 90.1 Compliant Units (48/50TM028 and 558F/580F300)	460	CRLOWAMB010A00	
	208/230	CRLOWAMB011A00	
	575	CRLOWAMB012A00	
15 and 17.5 Ton, Standard Tier Units (48/50TJ016,020 and 559F/579F180,216)	460	CRLOWAMB007A00	
	208/230	CRLOWAMB008A00	
	575	CRLOWAMB009A00	

Manufacturer reserves the right to discontinue, or change at any time, specifications or designs without notice and without incurring obligations.

## SAFETY CONSIDERATIONS

Installation, start-up, and servicing of this equipment can be hazardous due to system pressures, electrical components, moving parts, and equipment location.

Only trained, qualified installers and service mechanics should install, start up, and service this equipment. Untrained personnel can perform such basic maintenance functions as cleaning coils or replacing air filters. All other operations should be performed by trained service personnel only.

When working on equipment, observe precautions in literature; tags, stickers, and labels attached to equipment; and any other safety precautions that apply. Follow all safety codes, and wear safety glasses and work gloves. Use care in handling, rigging, and setting bulky equipment.

### ⚠ WARNING

Before performing service or maintenance operations on unit, turn off main power switch to unit. Electrical shock could result in personal injury.

### GENERAL

**IMPORTANT:** This accessory is designed for large rooftop units (12 to 25 tons) equipped with 3 outdoor-fan motors. The accessory low ambient kit and accessory winter start kit are required for installation.

The accessory Motormaster® I Solid-State Head Pressure Control is a fan speed control device actuated by a temperature sensor. It is specifically designed for use on Carrier equipment and controls the outdoor-fan motor speed in response to the saturated condensing temperature. For outdoor temperatures down to -20 F (-29 C), it maintains condensing temperatures at 100 F ± 10 F (38 C ± 5.5 C).

The Motormaster I controller must be used in conjunction with the Accessory Low Ambient Kit (part no. CRLOWAMB001A01). The Motormaster I device controls outdoor fan motor no. 1 while outdoor-fan motors no. 2 and 3 are sequenced off by the temperature switches in the accessory Low Ambient Kit. Refer to the Accessory Low Ambient Kit installation instructions for more information.

On 460-v and 575-v units, the no. 1 fan motor must be replaced with the supplied 208/230-v motor (part no. HC44GE208 for all units except 48/50TM028 and 559F/579F300 or part no. HC44GE209 for 48/50TM028 and 559F/579F300 units). A supplied single-phase transformer (part no. HT01AH859 for 575-v units or part no. HT01AH851 on 460-v units) is also required.

**IMPORTANT:** All units must be modified for winter start control. See instructions included with the accessory winter start control for more details.

The Motormaster I control consists of a solid-state circuit on a printed circuit board in an aluminum extrusion (to be fastened to a supplied bracket) and a sensor assembly (to be mounted to a return bend on the unit outdoor coil). A wire from the sensor is connected to the circuit board control box with wirenuts.

## BEFORE INSTALLING

Inspect the contents of this accessory package before installing. File a claim with the shipper if contents are damaged or parts are missing.

Parts necessary for mounting the control and sensor are included in the package. If the sensor assembly is damaged, it can be replaced separately.

## INSTALLATION

**Step 1 — Install Wind Baffles** — Wind baffles must be field fabricated for all units to ensure proper cooling cycle operation at low-ambient temperatures. See Fig. 1 and 2 for baffle details. Use 20-gage (4.1-mm diameter) galvanized sheet metal or similar corrosion-resistant materials for the baffles.

### ⚠ CAUTION

Use extreme care when drilling screw holes and screwing in fasteners near outdoor coil to avoid damage to tubing.

Use field-supplied screws to attach baffles to the unit. Screws should be 1/4-in. (6-mm) diameter or larger. Drill required screw holes for mounting baffles.

### Step 2 — Mount Motormaster I Control

48/50HJ,TJ,TM (EXCEPT 028) AND 551A/581A/559F/579F/558F/580F (EXCEPT 300) — 208/230-V UNITS

1. Turn off power to unit.
2. Open control box. Using a voltage meter, check that no power is present at unit terminal block.
3. Install accessory 0° F (-17.8 C) low ambient kit (part no. CRLOWAMB001A01) per instructions supplied with the kit.
4. Mount Motormaster I control on supplied bracket in the location shown in Fig. 3.
5. Insert the snap bushing (supplied) in the hole located in the bottom left hand corner of the control box and route Motormaster I harness (supplied, part no. 50TJ401124) through the bushing.

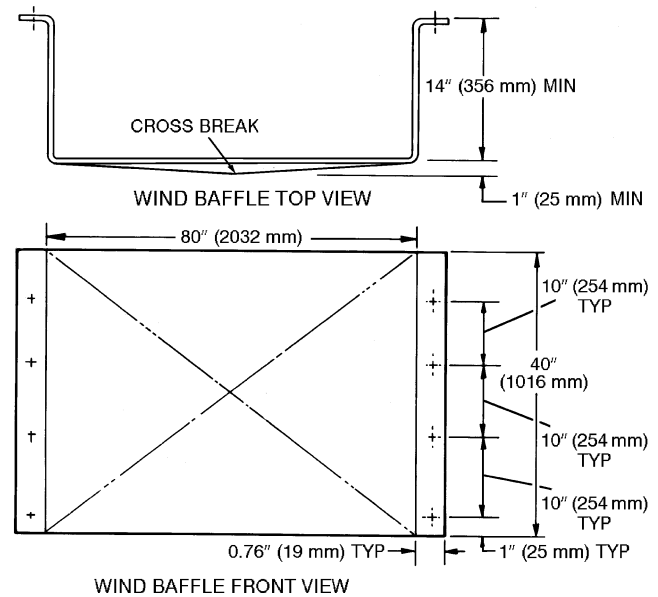

**Fig. 1 — Wind Baffle Detail  
(All Units Except 48/50TM028  
and 558F/580F300)**

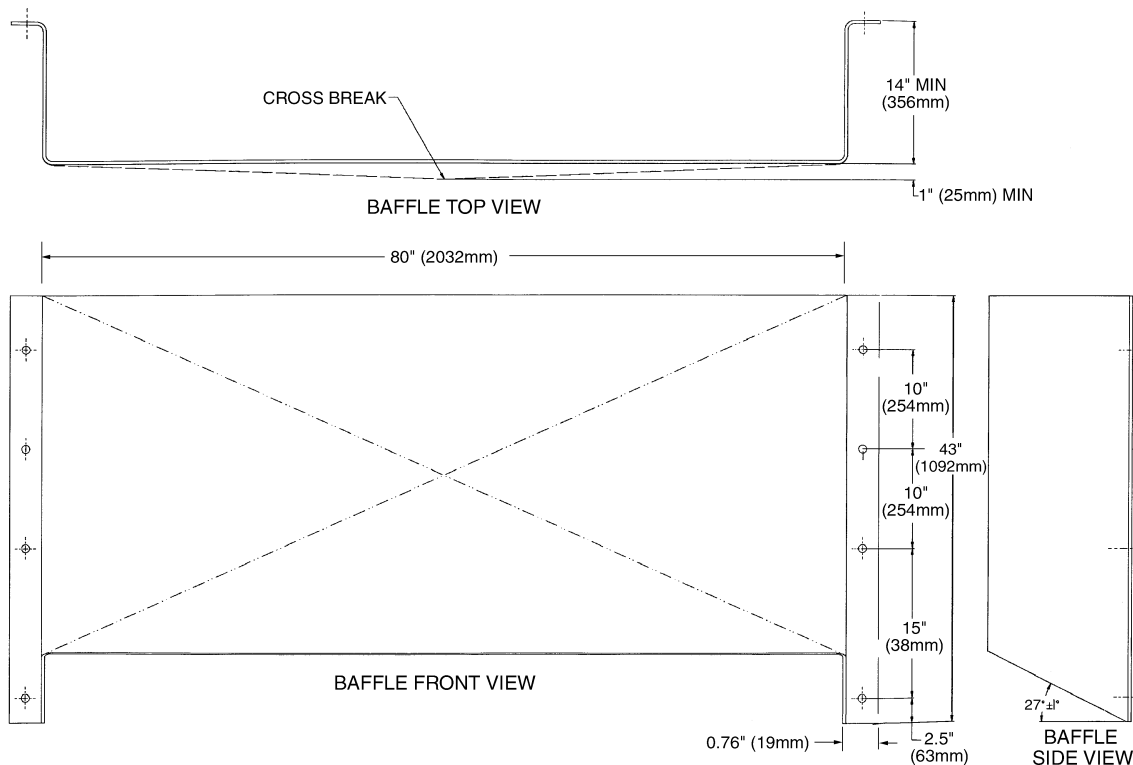

**Fig. 2 — Wind Baffle Details (48/50TM028 and 558F/580F300 Units)**

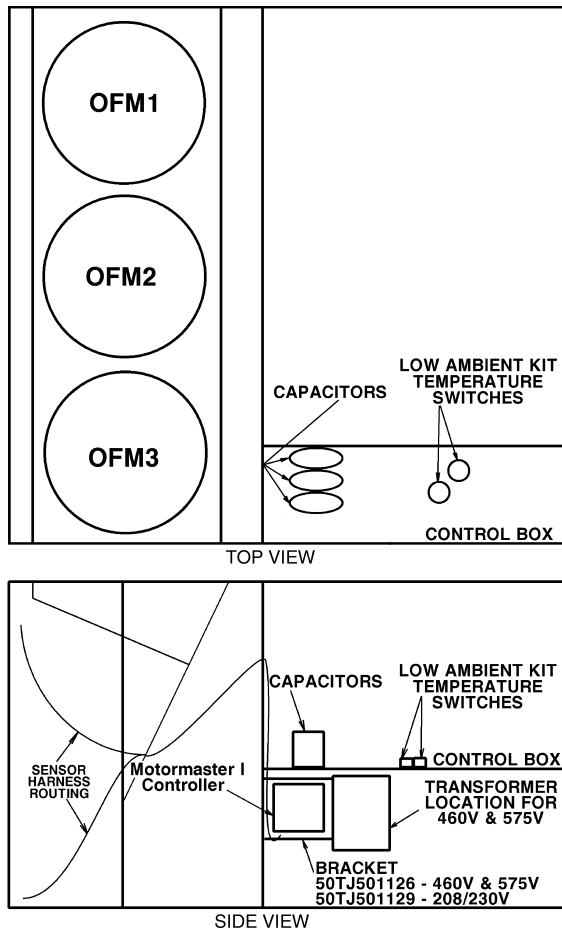

**Fig. 3 — Outdoor Fans and Motormaster® I Controller Locations (All Units Except 48/50TM028 and 558F/580F300)**

6. Rewire unit so that OFM1 is powered through the Motormaster I controller. See Fig. 4. The OFM2 and OFM3 will be powered by the line voltage. To rewire unit:
  - a. Connect GND on Motormaster I harness to control box with supplied screws. Attach bracket ground to Motormaster I bracket with supplied screws. On unit harness, locate the black wire connecting OFM1 to terminal C1-DU1. Remove the connection to terminal C1-DU1 and reconnect the wire to Motormaster I harness (OFM1-BLK). Connect C1 on Motormaster I harness to terminal C1-DU1 which OFM1 wire was connected.
  - b. Connect transformer terminals X2 and X3 together with a wire connector.
  - c. Complete all connections per harness wire labels. Wire tie the harness(s) and unused wires to the existing control box harness.
7. Replace all panels on unit and turn power on.

48/50HJ,TJ,TM (EXCEPT 028) AND 551A/581A/559F/579F558F/580F (EXCEPT 300) — 460-V AND 575-V UNITS

1. Turn off power to unit.
2. Open control box. Using a voltage meter, check that no power is present at unit terminal block.
3. Install accessory 0° F (-17.8 C) low ambient kit (part no. CRLOWAMB001A01) per instructions supplied with the kit.
4. Mount Motormaster I control on supplied bracket in the location shown in Fig. 3.
5. Mount supplied transformer (part no. HT01AH859 for 575-v units, HT01AH851 for 460-v units) and Motormaster I control on supplied bracket in the location shown in Fig. 1.

6. Replace outdoor-fan motor OFM1 with supplied 208/230-v motor (part no. HC44GE208). Make sure the motor wires go through the plastic conduit and the plastic conduit extends through the outdoor fan deck into the compressor section. Secure the motor wires to the fan deck so they do not come into contact with the rotating fans. Position the outdoor fan in the orifice using the other fans as a reference.
7. Punch out the 2-in. diameter knockout in the bottom of the control box. Insert the supplied snap bushing in the hole. Route the Motormaster® I harness through the bushing.
8. Rewire unit so that OFM1 is powered through the supplied 230-v transformer. See Fig. 5. The OFM2 and OFM3 will be powered by the line voltage.

9. To rewire unit:
  - a. Connect GND on supplied harness to control box with supplied screws. Attach bracket ground to supplied bracket with supplied screws. Attach MTRAN ground to the screw on the side of the transformer.
  - b. On unit harness, locate the black wire connecting OFM1 to terminal OFC-11 or C1-21. Remove the connection to terminal OFC-11 or C1-21 and connect the wire to Motormaster I harness (OFM1-BLK). Connect (LINE) on Motormaster I harness to terminal which OFM1 wire was connected (OFC-11 or C1-21).
  - c. Connect OFC1 on Motormaster I harness to terminal OFC-11 (single pole contactor) or OFC-13 (double pole contactor).

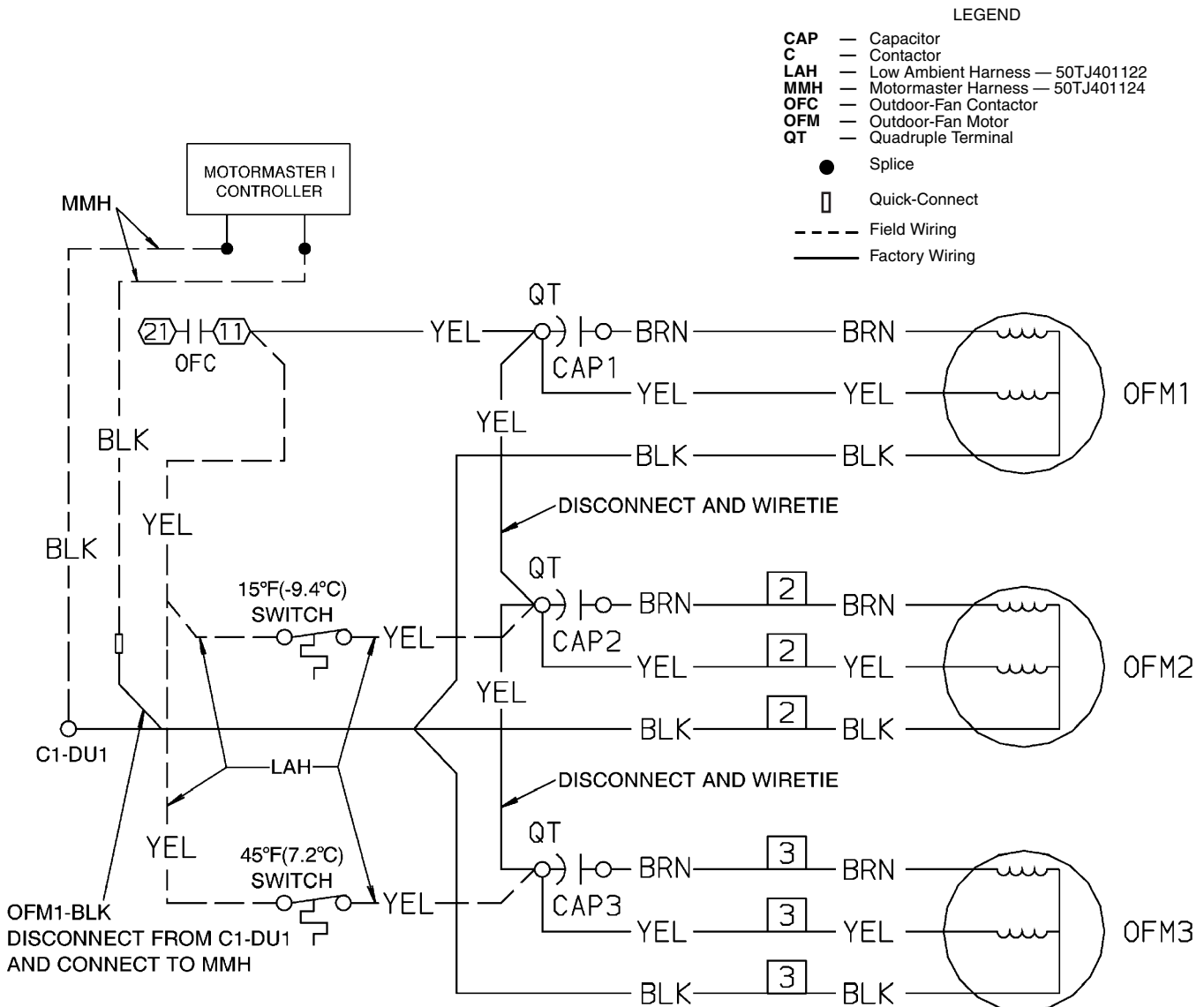



- d. Connect transformer terminals X2 and X3 (and for 460 v only — H2 and H3) together with a wire connector.
- e. Complete all connections per harness wire labels. Wire tie the harness(s) and unused wires to the existing control box harness.

10. Replace all panels on unit and turn power on.

**50HJQ AND 542J — 208/230-V UNITS**

1. Turn off power to unit.
2. Open control box. Using a voltage meter, check that no power is present at unit terminal block.
3. Install accessory 0° F (-17.8 C) low ambient kit (part no. CRLOWAMB001A01) per instructions supplied with the kit.
4. Mount Motormaster® I control on supplied bracket in the location shown in Fig. 3.
5. Insert the supplied snap bushing in the hole located in the bottom left hand corner of the control box and route Motormaster I harness through the bushing.
6. Rewire unit so that OFM1 is powered through the Motormaster I controller, but controlled by the heater

contactor. See Fig. 6. The OFM2 and OFM3 will be powered by the line voltage. To rewire unit:

- a. Connect GND on Motormaster I harness to control box with supplied screws. Attach bracket ground to supplied bracket with supplied screws.
- b. On unit harness, locate the black wire connecting OFM1 to terminal OFC-11. Remove the connection to terminal OFC-11 and connect the wire to Motormaster I harness (OFM1-BLK). Connect OFC1-11 on Motormaster I harness to OFC-11.
- c. Complete all connections per harness wire labels. Wire tie the harness(s) and unused wires to the existing control box harness.

7. Replace all panels on unit and turn power on.

**50HJQ AND 542J — 460-V AND 575-V UNITS**

1. Turn off power to unit.
2. Open control box. Using a voltage meter, check that no power is present at unit terminal block.
3. Install accessory 0° F (-17.8 C) low ambient kit (part no. CRLOWAMB001A01) per instructions supplied with the kit.

- LEGEND**
- CAP** — Capacitor
  - HC** — Heater Contactor (included in Low Ambient accessory kit)
  - HR** — Heater Relay
  - HPH** — Heat Pump Harness — 50HJ403218
  - LAH** — Low Ambient Harness — 50TJ401122
  - MMH** — Motormaster Harness — 50TJ403219
  - OFC** — Outdoor-Fan Contactor
  - OFM** — Outdoor-Fan Motor
  - QT** — Quadruple Terminal
  - TB** — Terminal Block
- Splice
  - Quick-Connect
  - Field Wiring
  - Factory Wiring

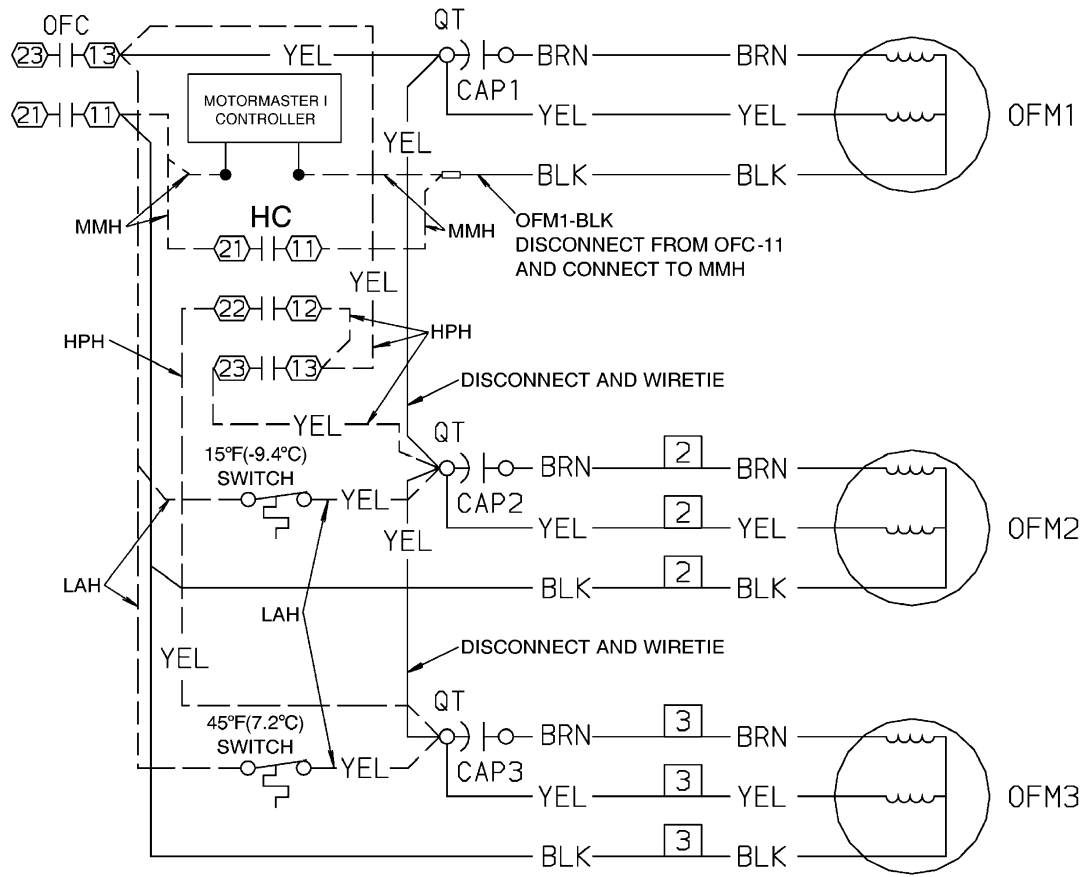
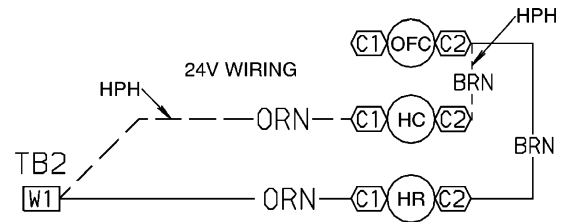

**Fig. 6 — Wiring Diagram — 50HJQ and 542J — 208/230-V Units**

4. Mount Motormaster® I control on supplied bracket in the location shown in Fig. 3.
5. Mount supplied transformer (part no. HT01AH859 for 575-v units, HT01AH851 for 460-v units) on supplied bracket in the location shown in Fig. 3.
6. Mount heater contactor no. 2 HC2 (supplied) near the outdoor-fan contactor (OFC) in the unit control box.
7. Replace outdoor-fan motor OFM1 with supplied 208/230-v motor. Make sure the motor wires go through the plastic conduit and the plastic conduit extends through the outdoor fan deck into the compressor section. Secure the motor wires to the fan deck so they do not come into contact with the rotating fans. Position the outdoor fan in the orifice using the other fans as a reference.
8. Punch out the 2-in. diameter knock-out in the bottom of the control box. Insert the snap bushing (supplied) in the hole and route Motormaster I harness through the bushing.
9. Rewire unit so that OFM1 is powered through the supplied 230-v transformer. See Fig. 7. The OFM2 and

OFM3 will be powered by the line voltage. To rewire unit:

- a. Connect GND on Motormaster I (50TJ401125) harness to control box with supplied screws. Attach bracket ground to supplied bracket with supplied screws. Attach MTRAN ground to the screw on the side of the transformer.
- b. On unit harness, locate the black wire connecting OFM1 to terminal OFC-11. Remove the connection to terminal OFC-11 and reconnect the wire to Motormaster I harness (OFM1-BLK). Connect (LINE) on Motormaster I harness to OFC-11.
- c. Connect OFC1 on Motormaster I harness to terminal OFC-13.
- d. Connect transformer terminals X2 and X3 (460 v only — H2 and H3) together with a wire connector. Use harness supplied (50HJ403220) for remaining HC1 to HC2 connections.
- e. Complete all connections per harness wire labels. Wire tie the harness(s) and unused wires to the existing control box harness.

10. Replace all panels on unit and turn power on.

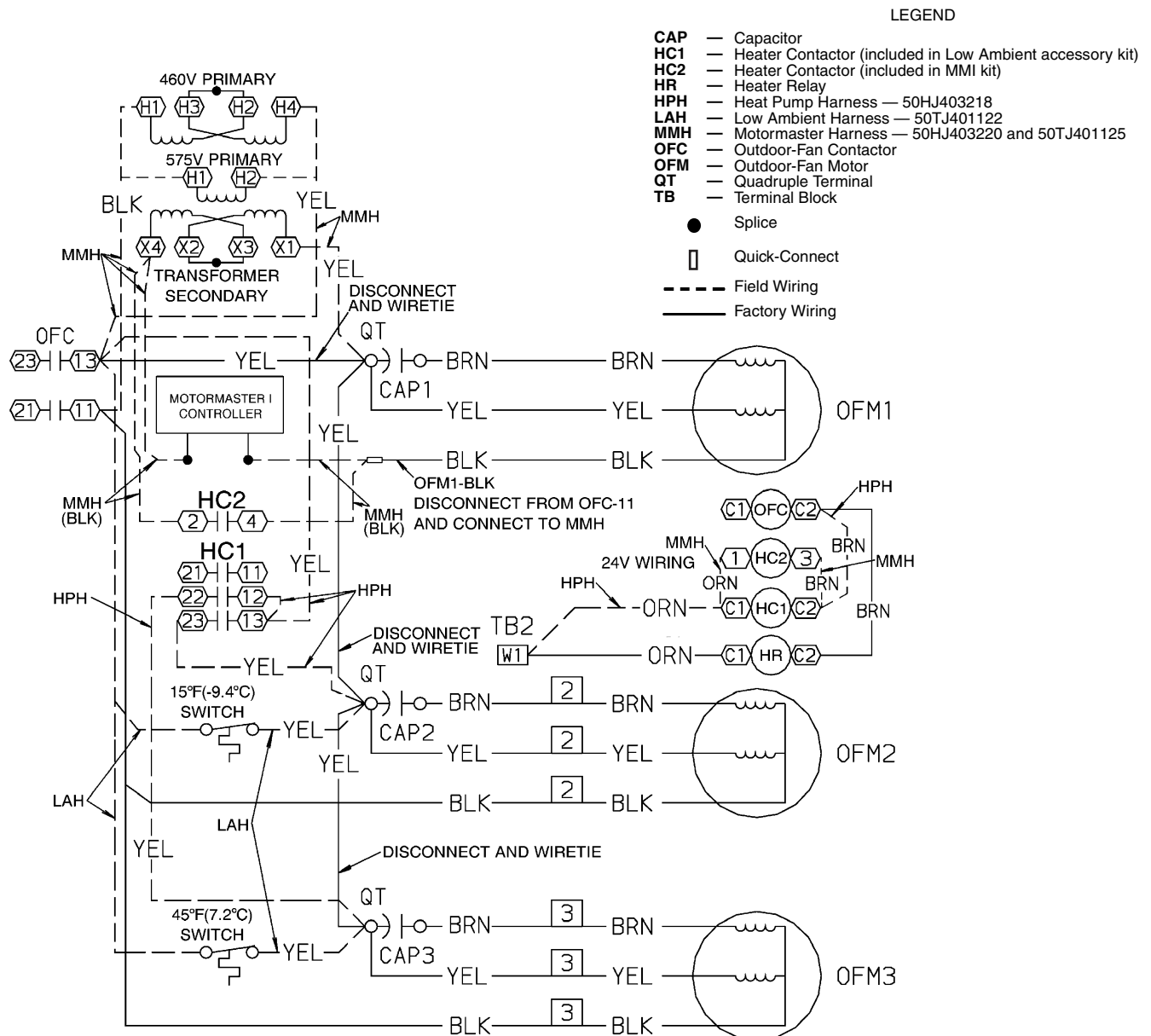

Fig. 7 — Wiring Diagram — 50HJQ and 542J — 460-V and 575-V Units

48/50TM028 AND 558F/580F300 — 208/230-V UNITS

1. Turn off power to unit.
2. Open control box. Using a voltage meter, check that no power is present at unit terminal block.
3. Install accessory 0° F (-17.8 C) low ambient kit (part no. CRLOWAMB001A01) per instructions supplied with the kit.
4. Mount two Motormaster® I controls (MM1 and MM2) on supplied brackets in the locations shown in Fig. 8.
5. Insert the snap bushing (supplied) in the hole and route Motormaster I harness through the bushing.
6. Rewire unit so that OFM1 and OFM4 are powered through the two Motormaster I controllers (MM1 and MM2). See Fig. 9. The OFM2, OFM3, OFM5 and OFM6 fan motors will be powered by the line voltage. To rewire unit:
  - a. Connect GND on Motormaster I harness to control box with supplied screws. Attach bracket ground
  - b. On unit harness, locate the black wire connecting OFM1 to terminal C1-DU1. Remove the connection to terminal C1-DU1 and reconnect the wire to first Motormaster I harness (OFM1-BLK). Connect C1 on first Motormaster I harness to terminal which OFM1 wire was connected (C1-DU1).
  - c. On unit harness, locate the black wire connecting OFM4 to terminal C2-DU1. Remove the connection to terminal C2-DU1 and reconnect the wire to remaining Motormaster I harness (OFM4-BLK). Connect C2 on remaining Motormaster I harness to terminal which OFM4 wire was connected (C2-DU1).
  - d. Complete all connections per harness wire labels. Wire tie the harness(s) and unused wires to the existing control box harness.
7. Replace all panels on unit and turn power on.

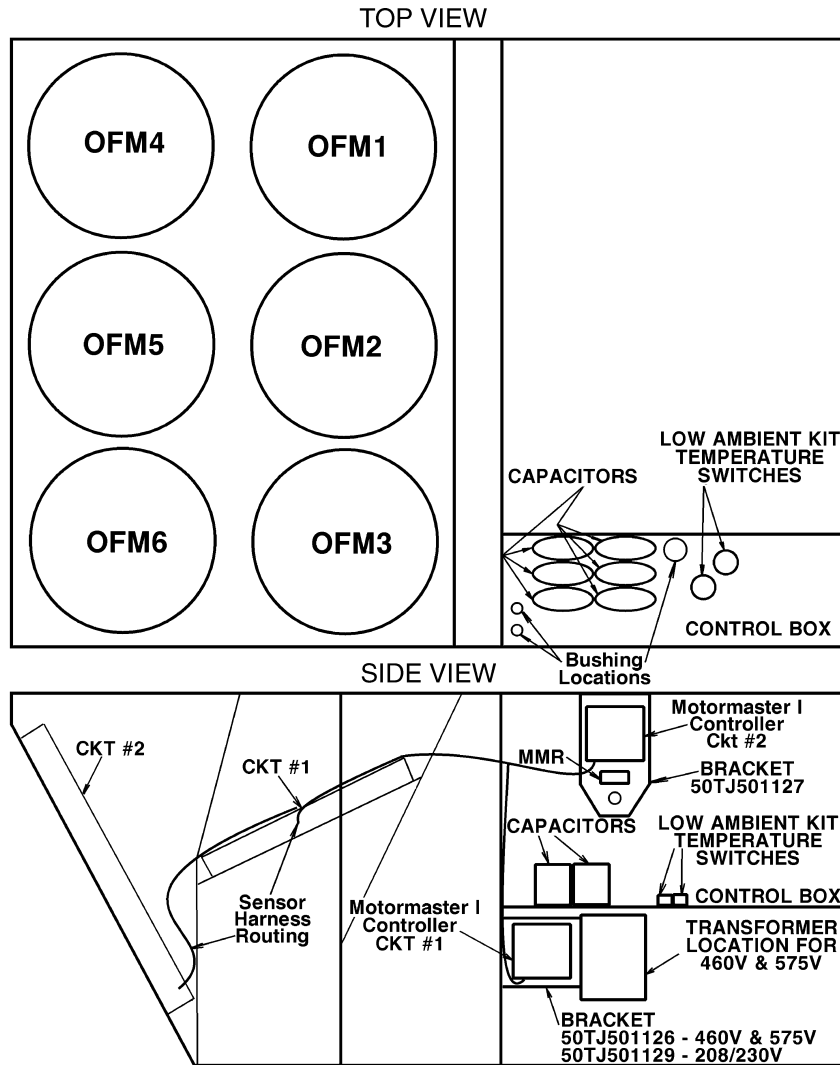
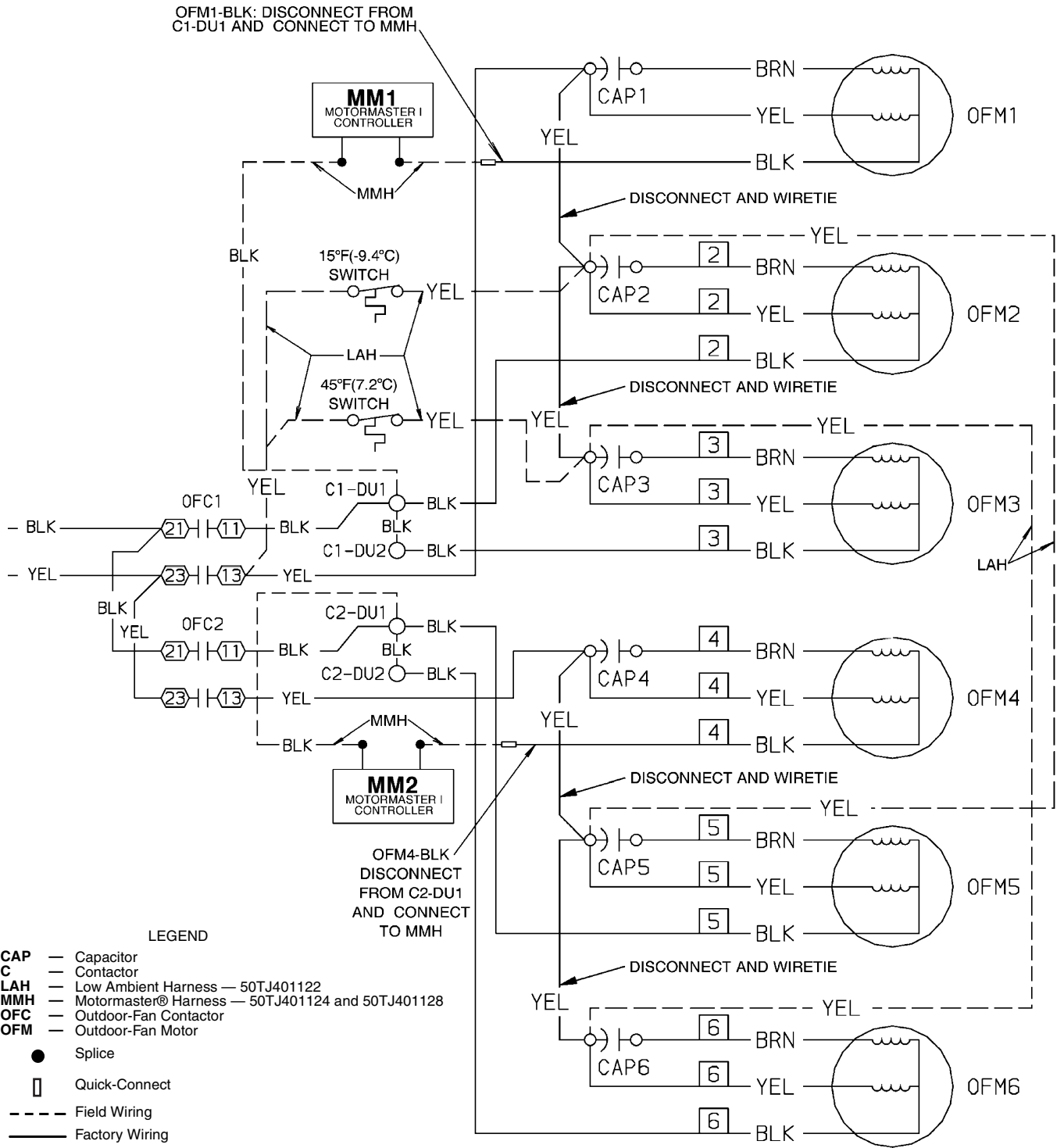

Fig. 8 — Outdoor Fans and Motormaster I Controller Locations — 48/50TM028 and 558F/580F300 Units



**Fig. 9 — Wiring Diagram — 48/50TM028 and 558F/580F300 — 208/230-V Units**

48/50TM028 AND 558F/580F300 — 460-V AND 575-V UNITS

1. Turn off power to unit.
2. Open control box. Using a voltage meter, check that no power is present at unit terminal block.
3. Install accessory 0° F (-17.8 C) low ambient kit (part no. CRLOWAMB001A01) per instructions supplied with the kit.
4. Mount two Motormaster® I controls on supplied brackets in the locations shown in Fig. 8.
5. Mount supplied transformer (part no. HT01AH859 for 575-v units, HT01AH851 for 460-v units) on supplied bracket in the location shown in Fig. 8.
6. Replace 2 outdoor-fan motors OFM1 and OFM4 with supplied 208/230-v motors (part no. HC44GE209). Position the outdoor fan in the orifice using the other fans as a reference.

7. Punch out the 2-in. diameter knockout in the bottom of the control box. Insert the snap bushing (supplied) in the hole and route Motormaster I harness through the bushing.
8. Rewire unit so that OFM1 and OFM4 are powered through the supplied 230-v transformer (OFM4 is powered by 230-v transformer but is controlled by the Motormaster I relay). See Fig. 10. The OFM2, OFM3, OFM5 and OFM6 will be powered by the line voltage. To rewire unit:

  - a. Connect GND on first Motormaster I harness to control box with supplied screws. Attach bracket ground to supplied bracket with supplied screws. Attach MTRAN ground to the screw on the side of the transformer.

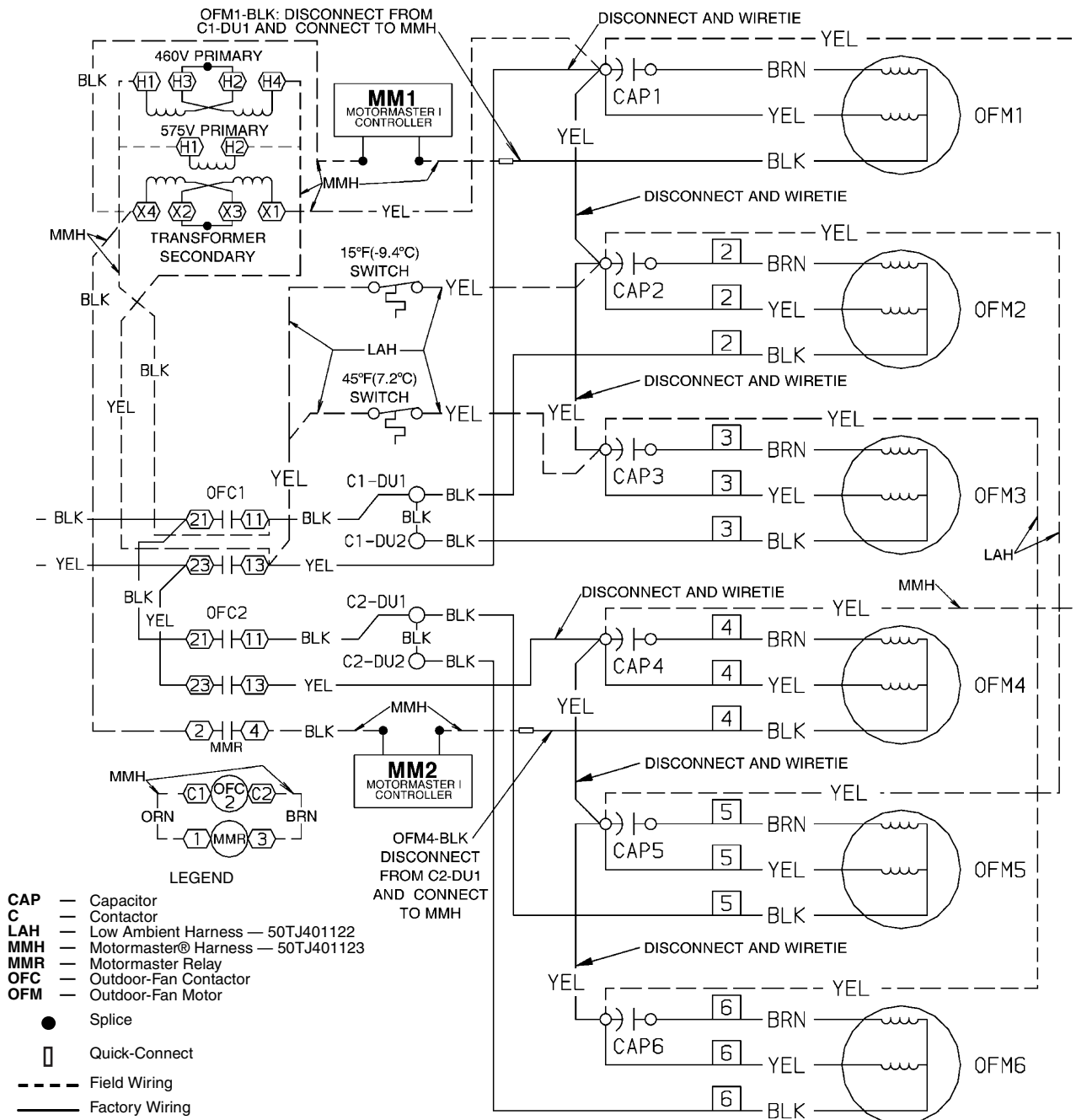
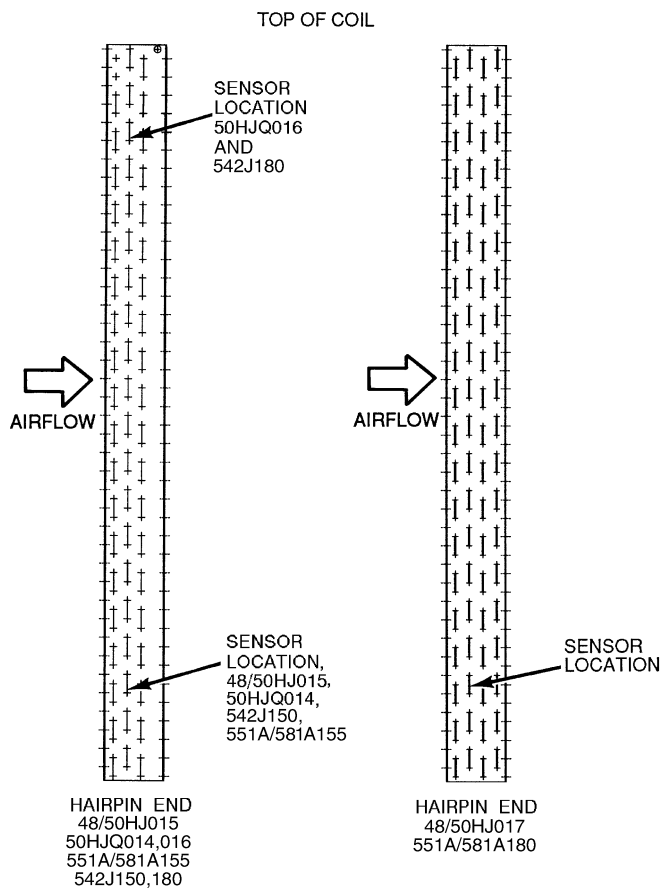

Fig. 10 — Wiring Diagram — 48/50TM028 and 558F/580F300 — 460-V and 575-V Units

- b. On unit harness, locate the black wire connecting OFM1 to terminal C1-DU1. Remove the connection to terminal C1-DU1 and reconnect the wire to first Motormaster® I harness (OFM1-BLK).
  - c. On unit harness, locate the black wire connecting OFM4 to terminal C2-DU1. Remove the connection to terminal C2-DU1 and reconnect the wire to remaining Motormaster I harness (OFM4-BLK).
  - d. Connect transformer terminals X2 and X3 (460 v only — H2 and H3) together with a wire connector.
  - e. Complete all connections per harness wire labels. Wire tie the harness(s) and unused wires to the existing control box harness.
9. Replace all panels on unit and turn power on.

### Step 3 — Mount Sensor Assembly

1. Remove outdoor-air section access panel on control box side of unit and corner post on hairpin end of outdoor coil.
2. Route sensor wire through the partition wall into outdoor section. See Fig. 3 and 8.
3. Mount sensor on an outdoor coil hairpin bend as shown in Fig. 11-13.
4. Secure the sensor on the coil hairpin bend with the 2 supplied no. 4-40 screws, plate washers, and 4-40 nuts.
5. Insert supplied snap bushing into  $\frac{7}{8}$ -in. hole in the bottom left-hand corner of the control box. Route sensor wire to area below the control box and then through bushing into control box. Connect sensor wire to Motormaster I control.
6. Coil up unused sensor wire and secure next to Motor-master I controller or sensor. Protect sensor wire from physical damage or wind movement as necessary.



**Fig. 11 — Sensor Location on Outdoor Coil, 48/50HJ; 50HJQ; 551A/581A/542J Units**

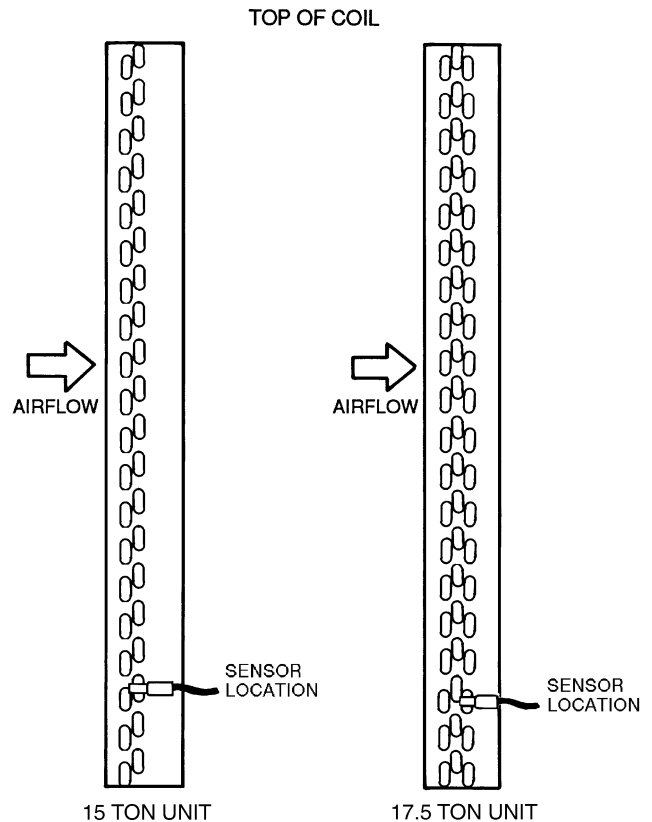

**Fig. 12 — Sensor Location on Outdoor Coil Hairpin Bend, 48/50TJ; 48/50TM016,020; 559F/579F; 558F/580F180,210 Units**

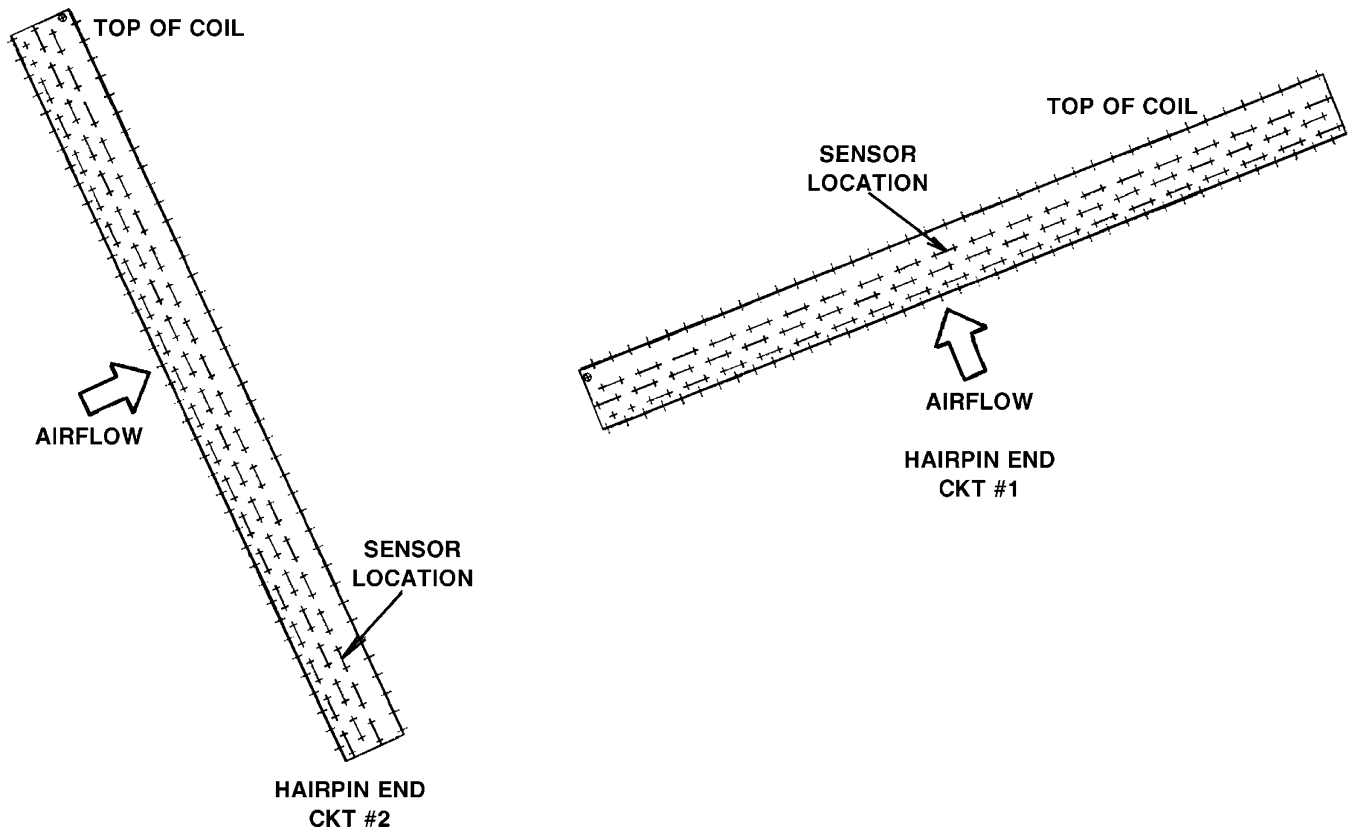

Fig. 13 — Sensor Location on Outdoor Coil Hairpin End, 48/50TM028 and 558F/580F300 Units