

Large Packaged Rooftop Units 12½ to 25 Tons 50/60 Hz Accessory Barometric Relief Damper

Cancels: New

IHK 542J-150-14
1/15/99

Installation Instructions

Part No. CRBARREL001A00

GENERAL

The accessory barometric relief damper part number CRBARREL001A00 is used on large packaged rooftop units to relieve building overpressurization.

NOTE: The barometric relief damper accessory cannot be used with the accessory horizontal supply roof curbs.

The barometric relief damper package contains:

- 1 — Accessory relief damper assembly (Fig. 1)
- 1 — Center post
- 1 — Insulated panel
- 7 — No. 10AB x ½-in. lg screws

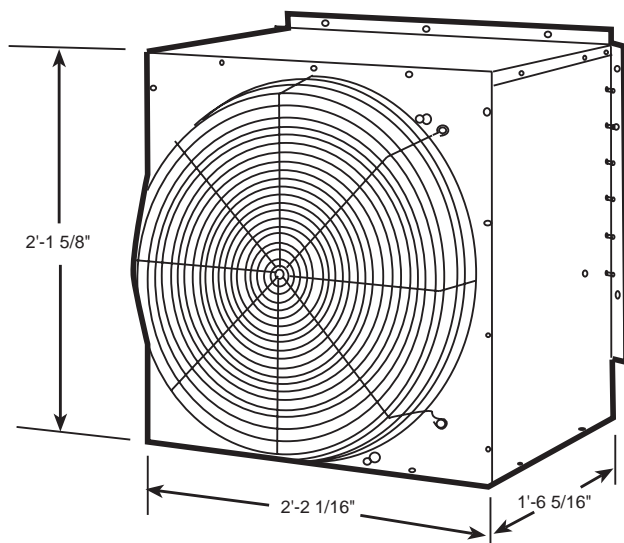

Fig. 1 — Accessory Relief Damper Assembly

INSTALLATION

1. Unpack accessory package.
2. Remove the alternate return air access panel (Fig. 2). Using screws just removed, install center post and insulated panel as shown in Fig. 3.
3. Position relief damper assembly in return air opening (Fig. 3). Use retainer on back of relief damper assembly to help with positioning (Fig. 4).
4. Using no. 10AB x ½ in. screws, fasten relief damper assembly to unit (Fig. 5).

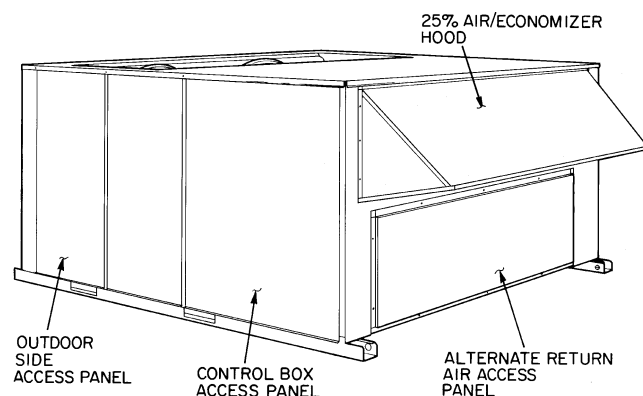

Fig. 2 — Typical Base Unit

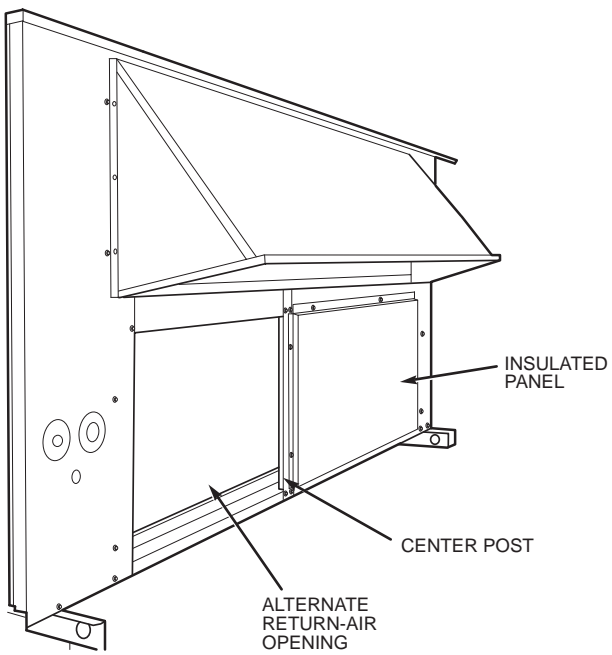

Fig. 3 — Base Unit Details

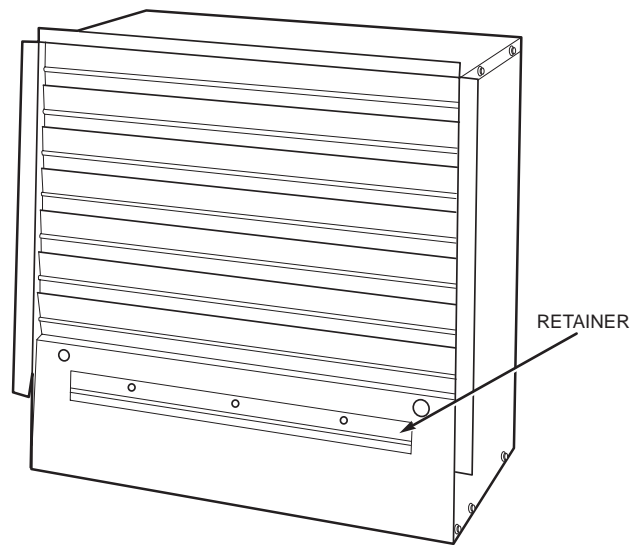

Fig. 4 — Relief Damper Assembly

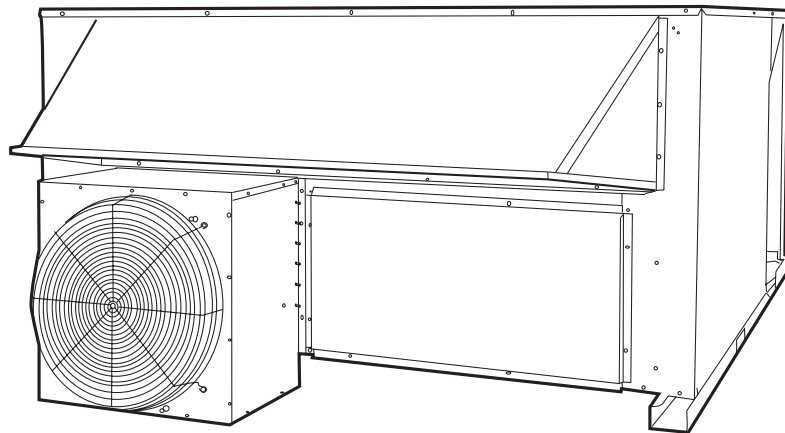

Fig. 5 — Base Unit with Relief Damper Assembly Installed