



# Installation Instructions

Part Number: CRHAILGD021A00

## SAFETY CONSIDERATIONS

Installation and servicing of air-conditioning equipment can be hazardous due to system pressure and electrical components. Only trained and qualified service personnel should install, repair, or service air-conditioning equipment.

Untrained personnel can perform basic maintenance functions of cleaning coils and filters and replacing filters. All other operations should be performed by trained service personnel. When working on air-conditioning equipment, observe precautions in the literature, tags and labels attached to the unit, and other safety precautions that may apply.

Follow all safety codes. Wear safety glasses and work gloves. Use quenching cloth for unbrazing operations. Have fire extinguishers available for all brazing operations.

## GENERAL

**IMPORTANT:** Read these instructions completely before attempting to install the accessory hail guard.

The accessory hail guard is designed to protect the condenser coil from hail, flying debris, and damage by large objects without increasing unit clearances or impacting unit efficiency.

## PACKAGE USAGE

UNIT 48/50PG	PART NUMBER
16	CRHAILGD021A00

## INSTALLATION

**⚠ WARNING**

Turn off unit power and lock out. Electrical shock and personal injury could result.

To install the hail guard, perform the following:

1. Make sure power supply is turned off and lockout tag is installed.
2. Remove the screws from around the perimeter of the condenser coil. Save screws. See Fig. 1.
3. Slide the top flange of the hail guard underneath the top flange of the unit.
4. With the hail guard in place, re-install the screws removed from Step 2 to secure the hail guard to the unit. See Fig. 1.

**⚠ CAUTION**

To avoid damage to the condenser coil, only install screws into the existing holes. Using self-drilling screws could damage the coil.

5. Remove lockout tag and restore power to unit.

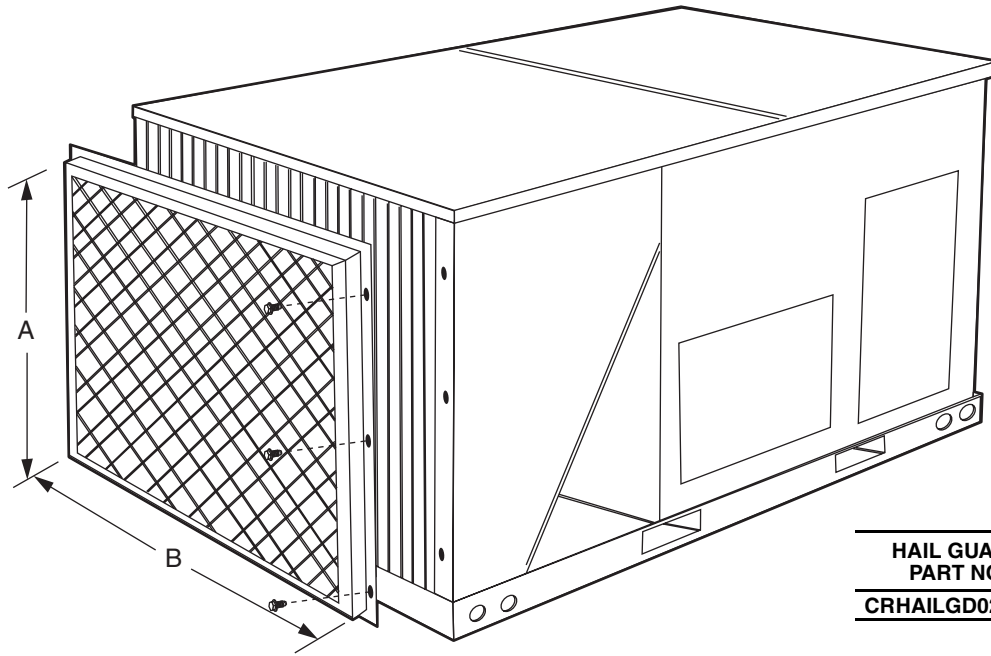

HAIL GUARD PART NO.	DIMENSIONS (in.)	
	A	B
CRHAILGD021A00	44.66	87.10

**Fig. 1 — Hail Guard Installation**