

48ES

Single-Packaged Gas Heating/Electric Cooling Units with Puron®  
(R-410A) Refrigerant Single- And Three-Phase Units  
1-1/2 to 5 Nominal Tons (Sizes 018-060)



Turn to the Experts.™

## Product Data

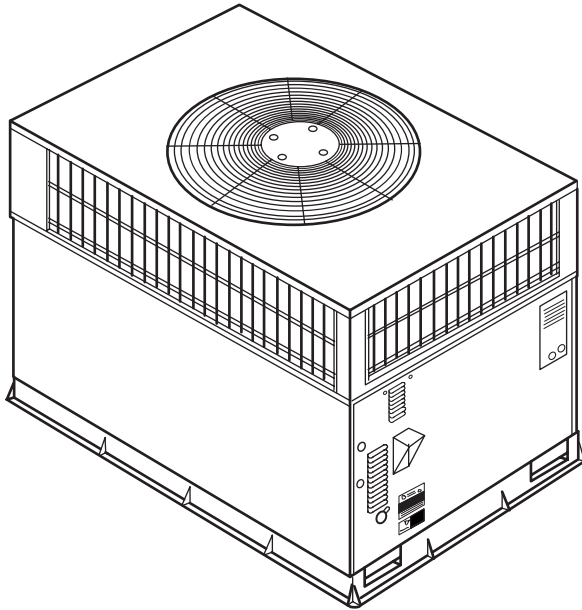

A99338

Unit 48ES

### FEATURES/BENEFITS

One-piece heating and cooling units with low sound levels, easy installation, low maintenance, and dependable performance.

**Puron Environmentally Sound Refrigerant** is Carrier's unique refrigerant designed to help protect the environment. Puron is an HFC refrigerant which does not contain chlorine that can harm the ozone layer. The most important advantage of Puron refrigerant is that it has not been banned in future air conditioning systems as the traditional refrigerant R-22 has been. Puron refrigerant is in service in over 100,000 systems proving highly reliable, environmentally sound performance.

#### Easy Installation

Factory-assembled package is a compact, fully self-contained, combination gas heating/electric cooling unit that is prewired, pre-piped, and pre-charged for minimum installation expense. These units are available in a variety of standard and optional heating/cooling size combinations with voltage options to meet residential and light commercial requirements. Units are lightweight and install easily on a rooftop or at ground level. The high tech composite base eliminates rust problems associated with ground level applications.

#### Convertible duct configuration

Unit is designed for easy use in either downflow or horizontal applications. Each unit is easily converted from horizontal to downflow with the two standard duct covers.

**Efficient operation High-efficiency design** offers SEER (Seasonal Energy Efficiency Ratios) of 13.0, and AFUE (Annual Fuel Utilization Efficiency) ratings as high as 81%.

Single-Packaged Products with Energy-Saving Features and Puron® refrigerant.

- 13 SEER
- Up to 81% AFUE
- Factory-Installed TXV
- Multi-Speed Blower-Standard
- Direct Spark Ignition
- Low Sound Levels

**Energy-saving, direct spark ignition** saves gas by operating only when the room thermostat calls for heating. Standard units are furnished with natural gas controls. A low-cost field installed kit for propane conversion is available for all units.

**48ESN units are dedicated Low NOx units** designed for California installations. These models meet the California maximum oxides of nitrogen (NOx) emissions requirement of 40 nanograms/joule or less as shipped from the factory and **MUST** be installed in California Air Quality Management Districts where a Low NOx rule exists. Low NOx option is available on single phase models only.

**Durable, dependable components Compressors** are designed for high efficiency. Each compressor is hermetically sealed against contamination to help promote longer life and dependable operation. Each compressor also has vibration isolation to provide quieter operation. All compressors have internal high pressure and overcurrent protection.

**Monoport inshot burners** produce precise air-to-gas mixture, which provides for clean and efficient combustion. The large monoport on the inshot (or injection type) burners seldom, if ever, requires cleaning. All gas furnace components are accessible in one compartment.

**Turbo-tubular™ heat exchangers** are constructed of aluminized steel for corrosion resistance and optimum heat transfer for improved efficiency. The tubular design permits hot gases to make multiple passes across the path of the supply air.

In addition, dimples located on the heat exchanger walls force the hot gases to stay in close contact with the walls, improving heat transfer.

**Direct-drive multi-speed blower motor** is standard on all 48ES models.

**Direct-drive PSC condenser-fan motors** are designed to help reduce energy consumption and provide for cooling operation down to 40°F (4.4°C) outdoor temperature. Motormaster® II low ambient kit is available as a field-installed accessory.

**Thermostat controls**

Time Guard® II anti-short cycle protection circuitry. If a non-corporate thermostat without anti-short cycle protection is used the Time Guard II field-installed anti-short cycle kit is recommended.

**Thermostatic Expansion Valve** - A hard shutoff, balance port TXV maintains a constant superheat at the evaporator exit (cooling cycle) resulting in higher overall system efficiency.

**Refrigerant system** is designed to provide dependability. Liquid filter driers are used to promote clean, unrestricted operation. Each unit leaves the factory with a full refrigerant charge. Refrigerant service connections make checking operating pressures easier.

**High and Low Pressure Switches** provide added reliability for the compressor.

**Indoor and Outdoor coils** are computer-designed for optimum heat transfer and efficiency. The indoor coil is fabricated from copper tube and aluminum fins and is located inside the unit for protection against damage. The outdoor coil is internally mounted on the top tier of the unit. Copper fin coils and pre-coated fin coils are available from the factory by special order. These coils are recommended in applications where aluminum fins are likely to be damaged due to corrosion. They are ideal for seacoast applications.

**TABLE OF CONTENTS**

Features/Benefits ..... 1–2  
 Model Number Nomenclature ..... 3  
 ARI Capacities ..... 4  
 Physical Data ..... 5  
 Options and Accessories ..... 6  
 Base Unit Dimensions ..... 8–9  
 Accessory Dimensions ..... 10  
 Selection Procedure ..... 11  
 Performance Data ..... 12–18  
 Typical Piping and Wiring ..... 19  
 Application Data ..... 20  
 Electrical Data ..... 21  
 Typical Wiring Schematics ..... 22–24  
 Controls ..... 25  
 Guide Specifications ..... 26–27

**Low sound ratings** ensure a quiet indoor and outdoor environment with sound ratings as low as 72dBA.

**Easy to service cabinets** provide easy single-panel accessibility to serviceable components during maintenance and installation. The basepan with integrated drain pan provides easy ground level installation with or without a mounting pad. Convenient handholds are provided to manipulate the unit on the jobsite. A nesting feature ensures a positive basepan to roof curb seal when the unit is roof mounted. A convenient 3/4-in. wide perimeter flange makes frame mounting on a rooftop easy.

**Standard metal duct covers** with insulation come with the unit and cover the horizontal duct openings. These can be left in place if the units are converted to downflow.

**Integrated Gas Control (IGC) board** provides safe and efficient control of heating and simplifies trouble-shooting through its built-in diagnostic function.

**Cabinets** are constructed of heavyduty, phosphated, zinc-coated prepainted steel capable of withstanding 500 hours in salt spray. Interior surfaces of the evaporator/heat exchanger compartment are insulated with cleanable semi-rigid insulation board, which keeps the conditioned air from being affected by the outdoor ambient temperature and provides improved indoor air quality. (Conforms to American Society of Heating, Refrigeration and Air Conditioning Engineers No. 62P.) The sloped drain pan minimizes standing water in the drain. An external drain is provided.

**Downflow operation** is easily provided in the field to allow vertical ductwork connections. The basepan utilizes knockout style seals on the bottom openings to ensure a positive seal in the horizontal air-flow mode.

# MODEL NUMBER NOMENCLATURE

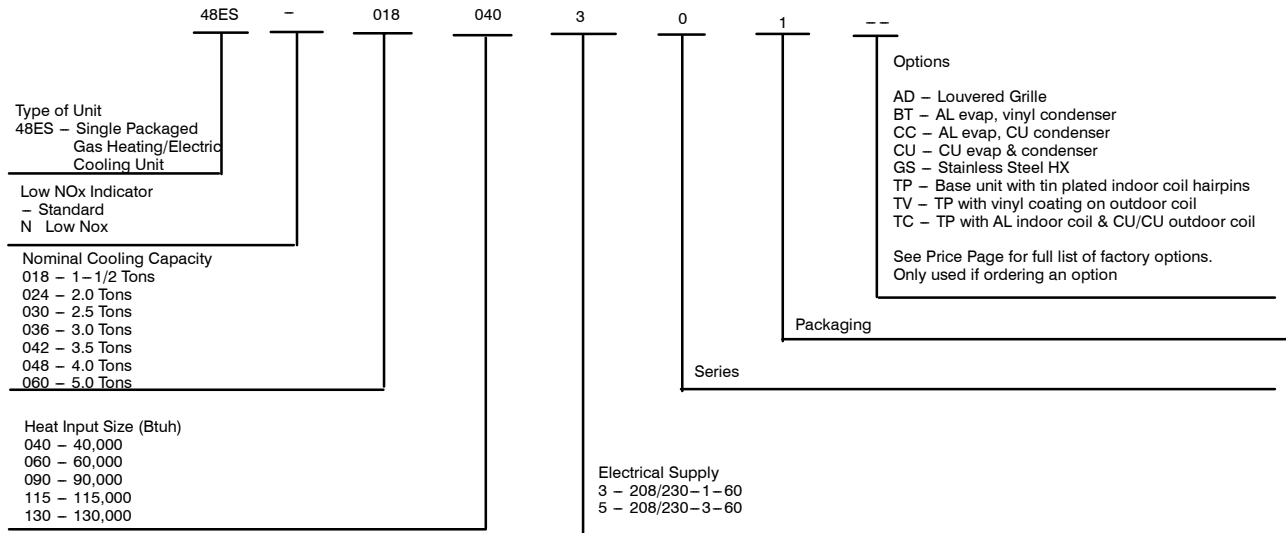

LEGEND  
 AL – Aluminum  
 CU – Copper

48ES



# ARI\* CAPACITIES

## COOLING CAPACITIES AND EFFICIENCIES

UNIT 48ES	NOMINAL TONS	STANDARD CFM	NET COOLING CAPACITIES (Btuh)	EER**	SEER†
018	1-1/2	650	18,000	10.7	13.0
024	2	800	23,000	11.2	13.2
030	2-1/2	1000	28,000	11.2	13.2
036	3	1200	34,000	11.2	13.5
042	3-1/2	1400	40,000	10.9	13.0
048	4	1600	46,500	10.9	13.2
060	5	1750	56,500	11.0	13.2

**LEGEND**

**dB**—Sound Levels (decibels)

**db**—Dry Bulb

**SEER**—Seasonal Energy Efficiency Ratio

**wb**—Wet Bulb

**COP**—Coefficient of Performance

**HSPF**—Heating Season Performance Factor

\* Air Conditioning & Refrigeration Institute.

\*\*At "A" conditions—80°F indoor db/67°F indoor wb & 95°F outdoor db.

† Rated in accordance with U.S. Government DOE Department of Energy) test procedures and/or ARI Standards 210/240—94.

**Notes:**

1. Ratings are net values, reflecting the effects of circulating fan heat.

Ratings are based on:

**Cooling Standard:** 80°F db, 67°F wb indoor entering—air temperature and 95°F db outdoor entering—air temperature.

2. Before purchasing this appliance, read important energy cost and efficiency information available from your retailer.

## GAS HEATING CAPACITIES AND EFFICIENCIES

UNIT 48ES	HEATING INPUT (Btuh)	OUTPUT CAPACITY (Btuh)	TEMPERATURE RISE RANGE (°F)	AFUE (%)
018040	40,000	32,000 (48ES) 31,000 (48ESN)	30-60	79.7 (48ES) 79.2 (48ESN)
024040 030040	40,000	32,000	20-50	80.1
024060 030060 036060 042060	60,000	47,000	35-65 35-65 25-55 25-55	78.4 78.4 78.7 78.7
036090 042090 048090 060090	90,000 90,000 90,000 90,000	72,000 72,000 71,000 71,000	40-70 40-70 25-55 25-55	79.9 79.9 78.5 78.6
048115 060115	115,000	93,000 (48ES) 90,000 (48ESN)	35-65	81.1 (48ES) 78.3 (48ESN)
048130 060130	130,000	104,000	40-70	80.3

**LEGEND**

**AFUE**—Annual Fuel Utilization Efficiency

NOTE: Before purchasing this appliance, read important energy cost and efficiency information available from your retailer.

## OUTDOOR SOUND: OCTAVE BAND DATA-DECIBELS

UNIT	48ES						
	018	024	030	036	042	048	060
Capacity							
Sound Ratings* dBA	72	76	73	76	74	79	78
Frequency (Hz)	dB						
125	58.0	61.5	63.0	64.5	61.5	66.5	64.0
250	60.5	65.0	64.5	70.0	65.5	70.5	71.0
500	67.5	71.5	68.5	70.0	68.0	73.0	69.5
1000	66.5	70.5	67.0	70.0	69.0	73.5	72.5
2000	62.5	66.5	64.0	66.5	66.5	69.5	71.0
4000	56.5	61.5	60.0	61.5	61.0	66.0	67.5
8000	48.5	55.0	54.0	53.0	56.5	59.5	60.0

\* Tested in accordance with ARI Standard 270—95 (not listed in ARI).

# PHYSICAL DATA

UNIT SIZE	018040	024040	024060	030040	030060	036060	036090	042060	042090
<b>NOMINAL CAPACITY (ton)</b>	1-1/2	2	2	2-1/2	2-1/2	3	3	3-1/2	3-1/2
<b>OPERATING WEIGHT lb.</b>	282	296	296	313	313	338	338	401	401
<b>OPERATING WEIGHT (kg)</b>	127.9	134.2	134.2	142.0	142.0	153.3	153.3	181.9	181.9
<b>COMPRESSORS</b>	Scroll								
Quantity	1								
<b>REFRIGERANT (R-410A)</b>									
Quantity (lb.)	5.0	6.9	6.9	8.0	8.0	9.2	9.2	8.8	8.8
Quantity (kg)	2.3	3.1	3.1	3.6	3.6	4.2	4.2	4.0	4.0
<b>REFRIGERANT METERING DEVICE</b>	TXV								
<b>CONDENSER COIL</b>									
Rows...Fins/in.	1...21	2...21	2...21	2...21	2...21	2...21	2...21	2...21	2...21
Face Area (sq ft)	10.2	10.2	10.2	11.9	11.9	13.6	13.6	15.5	19.4
<b>CONDENSER FAN</b>									
Nominal Cfm	2200	2200	2200	2800	2800	3000	3000	3500	3500
Diameter (in.)	22	22	22	22	22	22	22	22	22
Diameter (mm)	558.8	558.8	558.8	558.8	558.8	558.8	558.8	558.8	558.8
Motor Hp (Rpm)	1/8 (825)	1/8 (825)	1/8 (825)	1/8 (825)	1/8 (825)	1/8 (825)	1/8 (825)	1/8 (825)	1/8 (825)
<b>EVAPORATOR COIL</b>									
Rows...Fins/in.	3...17	3...17	3...17	3...17	3...17	4...17	4...17	3...17	3...17
Face Area (sq ft)	3.7	3.7	3.7	3.7	3.7	3.7	3.7	4.7	4.7
<b>INDOOR BLOWER</b>									
Nominal Airflow (Cfm)	650	800	800	1000	1000	1200	1200	1400	1400
Size (in.)	10x10	10x10	10x10	10x10	10x10	10x10	10x10	11x10	11x10
Size (mm)	254x254	254x254	254x254	254x254	254x254	254x254	254x254	279.4x254	279.4x254
Motor HP (RPM)	1/4 (825)	1/3 (1050)	1/3 (1050)	1/3 (1050)	1/3 (1050)	1/2 (1000)	1/2 (1000)	1/2 (1075)	1/2 (1075)
<b>FURNACE SECTION*</b>									
Burner Orifice No. (Qty...Drill Size)									
Natural Gas	2...44	2...44	2...38	2...44	2...38	2...38	3...38	2...38	2...38
Propane Gas	2...50	2...50	2...46	2...50	2...46	2...46	3...46	2...46	2...46
<b>HIGH-PRESSURE SWITCH (psig) Cut-out Reset (Auto)</b>	650 +/- 15 420 +/- 25								
<b>LOSS-OF-CHARGE / LOW-PRESSURE SWITCH (Liquid Line) (psig) cut-out Reset (auto)</b>	20 +/- 5 45 +/- 10								
<b>RETURN-AIR FILTERS†‡</b>	20x24x1 508x610x25 (mm)			24x30x1 610x762x25 (mm)			24x36x1 610x914x25 (mm)		

48ES

UNIT SIZE	048090	048115	048130	060090	060115	060130
<b>NOMINAL CAPACITY (ton)</b>	4	4	4	5	5	5
<b>OPERATING WEIGHT lb</b>	418	418	418	446	446	446
<b>OPERATING WEIGHT kg</b>	189.6	189.6	189.6	202.3	202.3	202.3
<b>COMPRESSORS</b>	Scroll					
Quantity	1					
<b>REFRIGERANT (R-410A)</b>						
Quantity (lb.)	9.0	9.0	9.0	10.5	10.5	10.5
Quantity (kg.)	4.1	4.1	4.1	4.8	4.8	4.8
<b>REFRIGERANT METERING DEVICE</b>	TXV					
<b>CONDENSER COIL</b>						
Rows...Fins/in.	2...21	2...21	2...21	2...21	2...21	2...21
Face Area (sq ft)	19.4	19.4	19.4	19.4	19.4	19.4
<b>CONDENSER FAN</b>						
Nominal Cfm	3500	3500	3500	4200	4200	4200
Diameter (in.)	22	22	22	22	22	22
Diameter (mm)	558.8	558.8	558.8	558.8	558.8	558.8
Motor Hp (Rpm)	1/4 (1100)	1/4 (1100)	1/4 (1100)	1/4 (1100)	1/4 (1100)	1/4 (1100)
<b>EVAPORATOR COIL</b>						
Rows...Fins/in.	3...17	3...17	3...17	4...17	4...17	4...17
Face Area (sq ft)	5.7	5.7	5.7	5.7	5.7	5.7
<b>INDOOR BLOWER</b>						
Max	1600	1600	1600	2000	2000	2000
Size (In.)	11x10	11x10	11x10	11x10	11x10	11x10
Size (mm)	279.4x254	279.4x254	279.4x254	279.4x254	279.4x254	279.4x254
Motor HP (RPM)	1/2 (1075)	1/2 (1075)	1/2 (1075)	1.0 (1040)	1.0 (1040)	1.0 (1040)
<b>FURNACE SECTION*</b>						
Burner Orifice No. (Qty...Drill Size)						
Natural Gas	3...38	3...33	3...31	3...38	3...33	3...31
Propane Gas	3...46	3...42	3...41	3...46	3...42	3...41
<b>HIGH-PRESSURE SWITCH (psig) Cut-out Reset (Auto)</b>	650 +/- 15 420 +/- 25					
<b>LOSS-OF-CHARGE / LOW-PRESSURE SWITCH (Liquid Line) (psig) cut-out Reset (auto)</b>	20 +/- 5 45 +/- 10					
<b>RETURN-AIR FILTERS (in.)†‡</b>	24x36x1 610x914x25 (mm)					

\*Based on altitude of 0 to 2000 ft.

† Required filter sizes shown are based on the larger of the ARI (Air Conditioning and Refrigeration Institute) rated cooling airflow or the heating airflow velocity of 300 ft/minute for throwaway type or 450 ft/minute for high-capacity type. Air filter pressure drop for non-standard filters must not exceed 0.08 in. wc.

‡ If using accessory filter rack refer to the filter rack installation instructions for correct filter sizes and quantity.

# OPTIONS AND ACCESSORIES

## Factory-installed options

**Louver grille** provides hail and vandalism protection. A wire grille is standard on all models. See model number nomenclature for louver grille options.

**Coil options** include copper/copper and vinyl-coated construction for refrigerant coils. Units are shipped standard with copper tube/aluminum fin construction. See model number nomenclature for coil options.

## Field-installed accessories

<b>Economizer with Solid-State Controls and Barometric Relief Dampers</b>
<b>Manual Air Damper (25% open)</b>
<b>Filter Rack</b>
<b>Flat Roof Curbs (8-in. and 14-in.)</b>
<b>Square-to-Round Duct Transition Kit</b>
<b>Thermostats</b>
<b>Crankcase Heater</b>
<b>Compressor Hard Start Kit (for use on single-phase units only)</b>
<b>Natural-to-propane Gas Conversion Kit</b>
<b>High Altitude Propane Conversion Kit</b>
<b>Propane-to-natural Gas Conversion Kit</b>
<b>Rigging Kit</b>
<b>Low Ambient Kit (Motormaster® II Control)</b>
<b>Solid-State Time Guard® II Device</b>

**Economizer with solid-state controls and barometric relief dampers** includes filter racks and provide outdoor air during cooling and reduce compressor operation.

**Manual outside air damper** includes hood and filter rack with adjustable damper blade for up to 25% outdoor air.

**Flat roof curbs** in both 8 in. and 14 in. sizes are available for roof mounted applications.

**Square-to-round duct transition kit** enables 018-048 size units to be fitted to 14 in. round ductwork.

**Compressor hard start kit** assists compressor start-up by providing additional starting torque on single phase units and prolongs compressor motor life.

**Corporate Thermostats** provide control for the system heating and cooling functions. Thermostat models are available in both programmable and non-programmable versions.

**Crankcase heater** provides anti-floodback protection for low-load cooling applications.

**Natural-to-propane gas conversion kit** allows for conversion from natural gas to propane gas for standard altitude (0 to 2000 ft above sea level).

**Rigging kit** includes lifting brackets which are inserted into the unit base rigging holds to lift unit for rooftop applications.

**Low-ambient kit (Motormaster II control)** allows the use of mechanical cooling down to outdoor temperatures as low as 0°F when properly installed.

**Solid-state Time Guard II device** provides short-cycling protection for the compressor. Not required with corporate electronic thermostats.

**Filter rack** features easy installation, serviceability, and high-filtering performance for vertical applications.

**High altitude propane conversion kit** is for use at 2001 to 6000 ft above sea level. Kit consists of propane gas orifices that compensate for gas heat operation at high altitude.

**Propane-to-natural conversion kit** is for use at standard altitudes (0 to 2000 ft above sea level). Kit contains natural gas orifices to convert the unit back to natural gas.

# ECONOMIZER

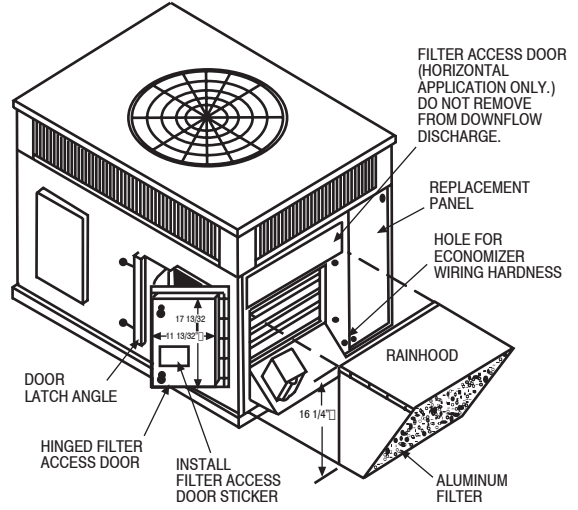
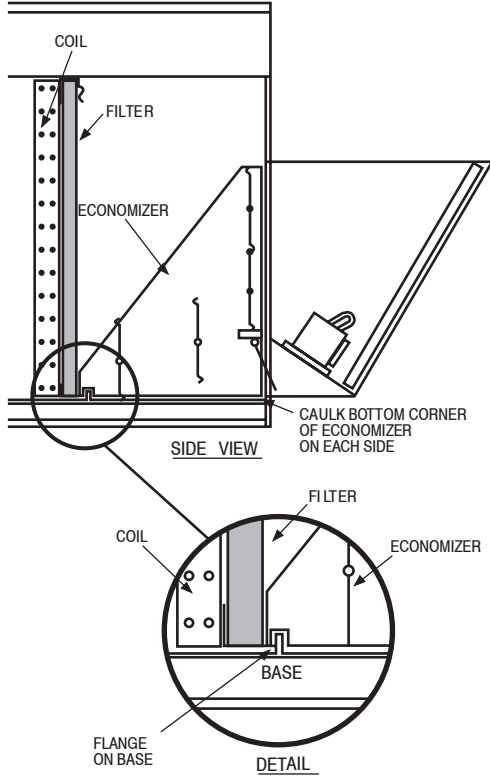

48ES

# FILTER RACK

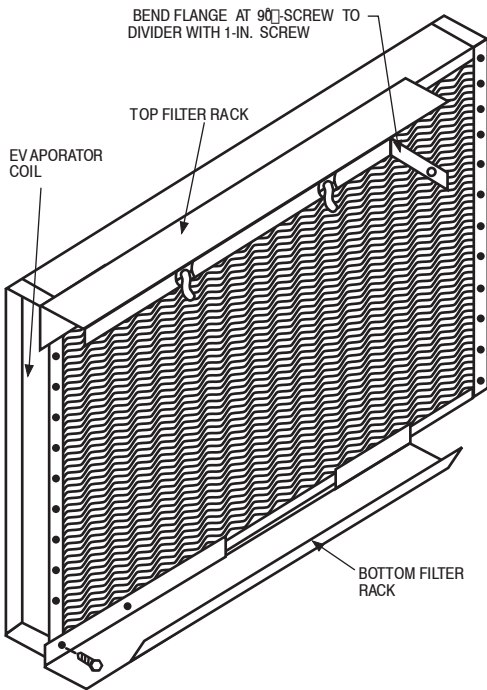

# MANUAL OUTSIDE AIR DAMPER

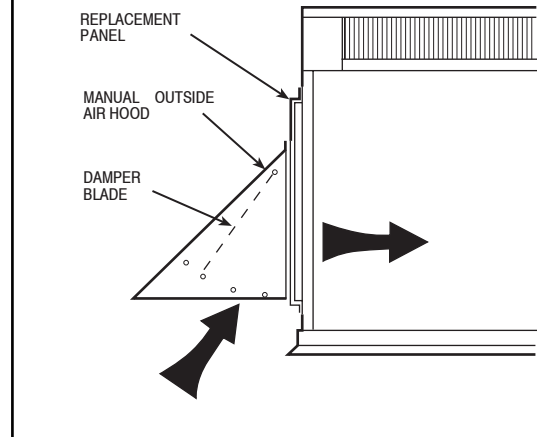

A05239

# UNIT DIMENSIONS - 48ES018-036

48ES

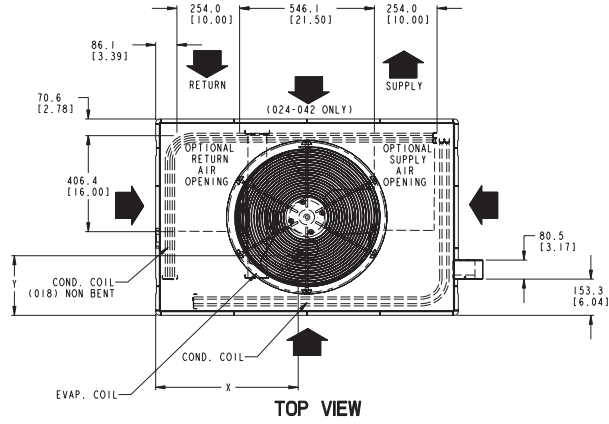
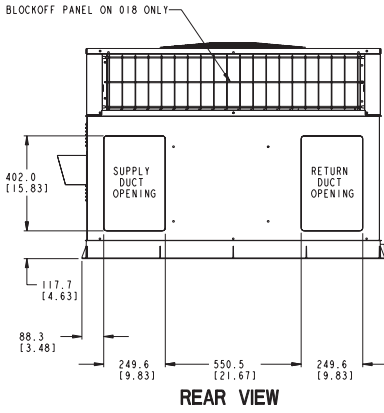

**REQUIRED CLEARANCE TO COMBUSTIBLE MATL**  
(Refer to Maximum Operating Clearances)

	INCHES	[mm]
TOP OF UNIT	14.00	[355.6]
DUCT SIDE OF UNIT	2.00	[50.8]
SIDE OPPOSITE DUCTS	14.00	[355.6]
BOTTOM OF UNIT	0.50	[12.7]

**NEC. REQUIRED CLEARANCES.**

	INCHES	[mm]
BETWEEN UNITS, POWER ENTRY SIDE	42.00	[1066.8]
UNIT AND UNGROUNDED SURFACES, POWER ENTRY SIDE	36.00	[914.0]
UNIT AND BLOCK OR CONCRETE WALLS AND OTHER GROUNDED SURFACES, POWER ENTRY SIDE	42.00	[1066.8]

**LEGEND**

- CG - Center of Gravity
- COND - Condensor
- EVAP - Evaporator
- NEC - National Electrical Code
- REQ'D - Required

NOTE: Dimensions are in in. [mm]

**REQUIRED CLEARANCE FOR OPERATION AND SERVICING**

	INCHES	[mm]
EVAP. COIL ACCESS SIDE	36.00	[914.0]
POWER ENTRY SIDE	42.00	[1066.8]
(EXCEPT FOR NEC REQUIREMENTS)		
UNIT TOP	48.00	[1219.2]
SIDE OPPOSITE DUCTS	36.00	[914.0]
DUCT PANEL	12.00	[304.8]

\*MINIMUM DISTANCES: IF UNIT IS PLACED LESS THAN 12.00 [304.8] FROM WALL SYSTEM, THEN SYSTEM PERFORMANCE MAYBE COMPROMISE.

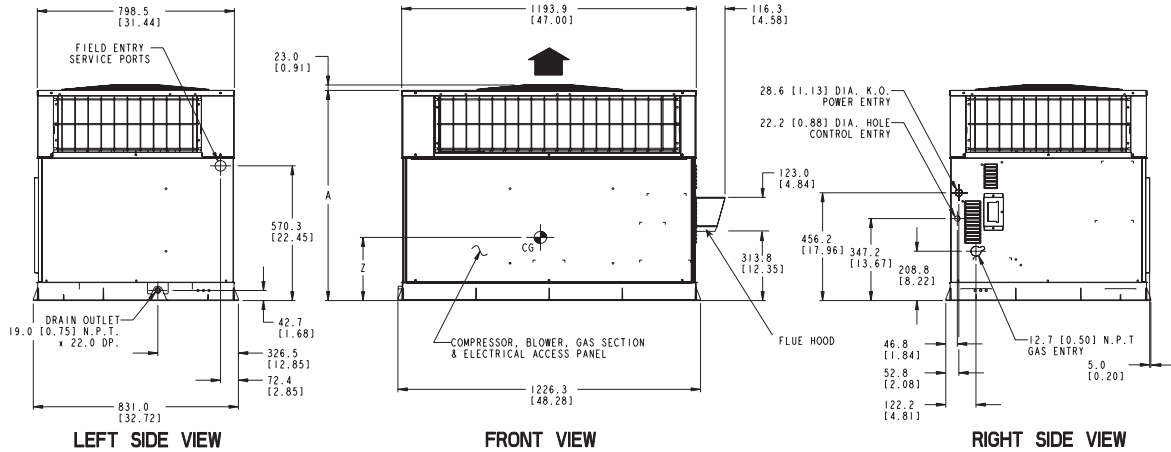

A05166

UNIT	ELECTRICAL CHARACTERISTICS	UNIT WEIGHT		UNIT HEIGHT IN. [MM] "A"	CENTER OF GRAVITY IN. [MM]		
		lb	kg		X	Y	Z
48ES018	208/230-1-60	282	127.9	37.02 [940]	23.3 [591.8]	15.5 [393.7]	15.5 [393.7]
48ES024	208/230-1-60	296	134.2	37.02 [940]	23.6 [599.4]	15.8 [401.3]	15.7 [398.8]
48ES030	208/230-1-60, 208/230-3-60	313	142.0	39.02 [991]	23.3 [591.8]	15.7 [398.8]	15.8 [401.3]
48ES036	208/230-1-60, 208/230-3-60, 460-3-60	338	153.3	41.02 [1042]	23.0 [584.2]	15.8 [401.3]	16.6 [421.6]

# UNIT DIMENSIONS - 48ES042-060

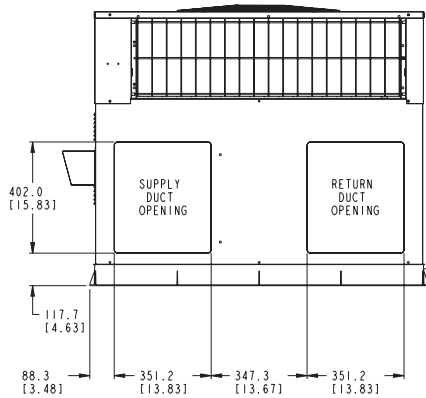

**REAR VIEW**

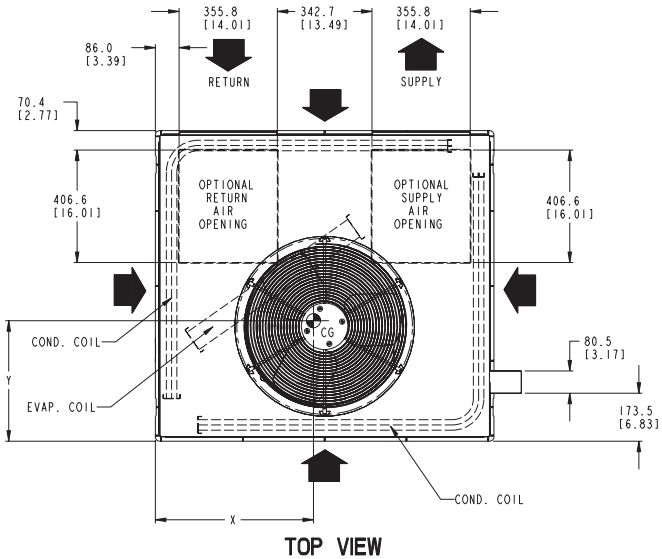

**TOP VIEW**

**48ES**

**REQUIRED CLEARANCE TO COMBUSTIBLE MATL**

	INCHES [mm]
TOP OF UNIT.....	14.00 [355.6]
DUCT SIDE OF UNIT.....	2.00 [50.8]
SIDE OPPOSITE DUCTS.....	14.00 [355.6]
BOTTOM OF UNIT.....	0.50 [12.7]
ELECTRIC HEAT PANEL.....	36.00 [914.4]

**NEC. REQUIRED CLEARANCES.**

	INCHES [mm]
BETWEEN UNITS, POWER ENTRY SIDE.....	42.00 [1066.8]
UNIT AND UNGROUNDED SURFACES, POWER ENTRY SIDE.....	36.00 [914.0]
UNIT AND BLOCK OR CONCRETE WALLS AND OTHER GROUNDED SURFACES, POWER ENTRY SIDE.....	42.00 [1066.8]

**REQUIRED CLEARANCE FOR OPERATION AND SERVICING**

	INCHES [mm]
EVAP. COIL ACCESS SIDE.....	36.00 [914.0]
POWER ENTRY SIDE.....	42.00 [1066.8]
(EXCEPT FOR NEC REQUIREMENTS)	
UNIT TOP.....	48.00 [1219.2]
SIDE OPPOSITE DUCTS.....	36.00 [914.0]
DUCT PANEL.....	12.00 [304.8] *

\*MINIMUM DISTANCES: IF UNIT IS PLACED LESS THAN 12.00 [304.8] FROM WALL SYSTEM, THEN SYSTEM PERFORMANCE MAYBE COMPROMISE.

**LEGEND**

- CG - Center of Gravity
- COND - Condenser
- EVAP - Evaporator
- NEC - National Electrical Code
- REQ'D - Required

NOTE: Dimensions are in in. [mm]

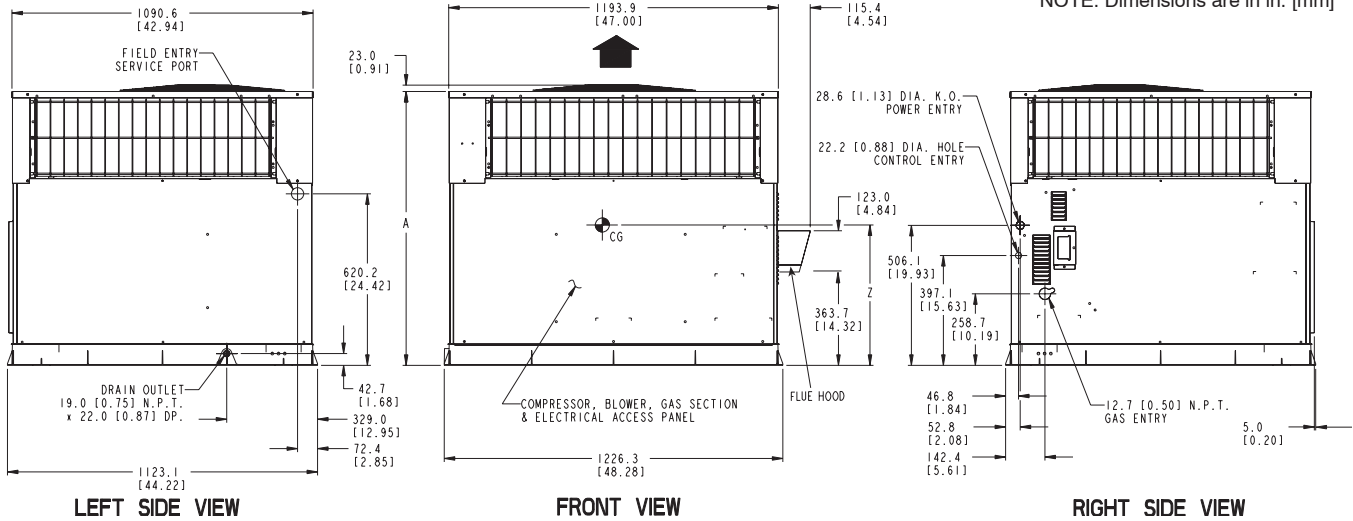

**LEFT SIDE VIEW**

**FRONT VIEW**

**RIGHT SIDE VIEW**

A05142

UNIT	ELECTRICAL CHARACTERISTICS	UNIT WEIGHT		UNIT HEIGHT IN. [MM] "A"	CENTER OF GRAVITY IN. [MM]		
		lb	kg		X	Y	Z
<b>48ES042</b>	208/230-1-60, 208/230-3-60, 460-3-60	401	181.9	42.98 [1092]	25.5 [647.7]	20.5 [520.7]	17.1 [434.3]
<b>48ES048</b>	208/230-1-60, 208/230-3-60, 460-3-60	418	189.6	42.98 [1092]	25.2 [640.1]	20.7 [525.8]	17.4 [442.0]
<b>48ES060</b>	208/230-1-60, 208/230-3-60, 460-3-60	446	202.3	46.98 [1193]	25.5 [647.7]	21.0 [533.4]	17.6 [447.0]

# ACCESSORY DIMENSIONS

48ES

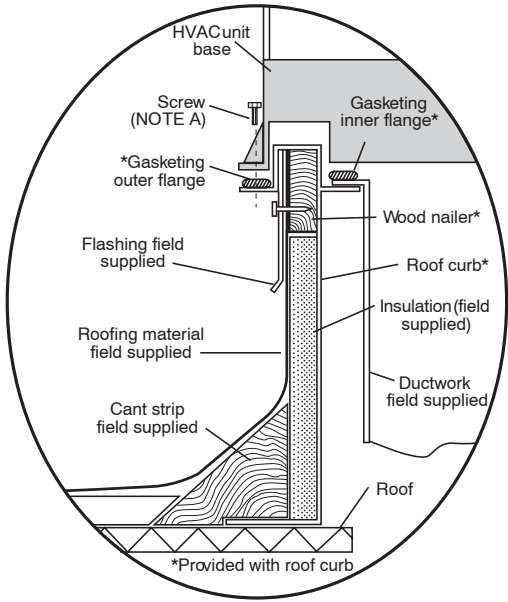

**Roof Curb for Small Cabinet**

Note A: When unit mounting screw is used, retainer bracket must also be used.

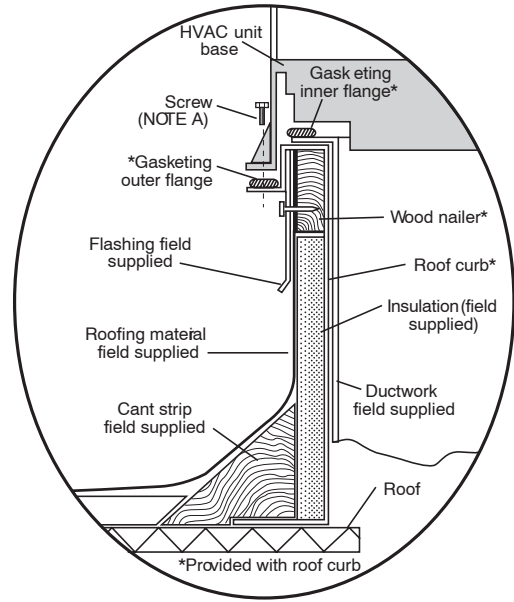

**Roof Curb for Large Cabinet**

Note A: When unit mounting screw is used, retainer bracket must also be used.

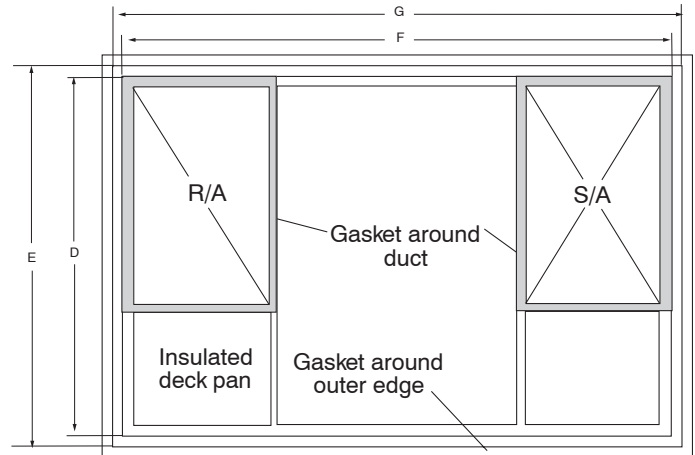
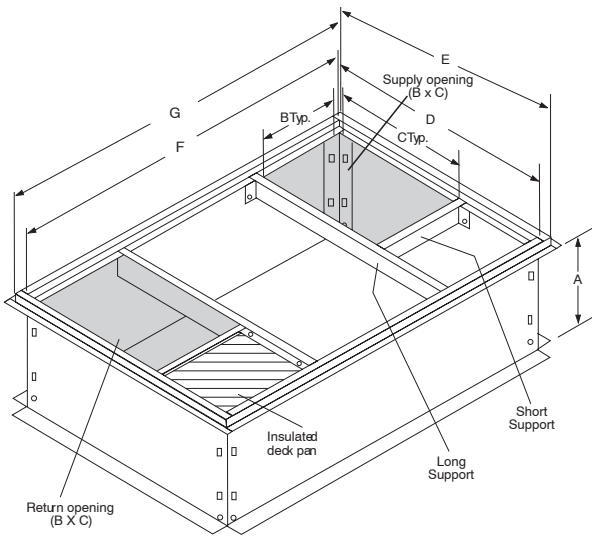

A05308

UNIT SIZE	ODS CATALOG NUMBER	A IN. (MM)	B IN. (MM)	C IN. (MM)	D IN. (MM)	E IN. (MM)	F IN. (MM)	G IN. (MM)
48ES018-036	CPRFCURB006A00	8 (203)	11 (279)	16-1/2 (419)	28-3/4 (730)	30-3/8 (771)	44-5/16 (1126)	45-15/16 (1167)
	CPRFCURB007A00	14 (356)	11 (279)	16-1/2 (419)	28-3/4 (730)	30-3/8 (771)	44-5/16 (1126)	45-15/16 (1167)
48ES042-060	CPRFCURB008A00	8 (203)	16-3/16 (411)	17-3/8 (441)	40-1/4 (1022)	41-15/16 (1065)	44-7/16 (1129)	46-1/16 (1169)
	CPRFCURB009A00	14 (356)	16-3/16 (411)	17-3/8 (441)	40-1/4 (1022)	41-15/16 (1065)	44-7/16 (1129)	46-1/16 (1169)

**NOTES:**

- Roof curb must be set up for unit being installed.
- Seal strip must be applied, as required, to unit being installed.
- Dimensions are in inches.
- Roof curb is made of 16-gauge steel.
- Attach ductwork to curb (flanges of duct rest on curb).
- Insulated panels: 1-in. thick fiberglass 1 lb. density.
- When unit mounting screw is used (see Note A), a retainer bracket must be used as well. This bracket must also be used when required by code for hurricane or seismic conditions. This bracket is available through Micrometl.

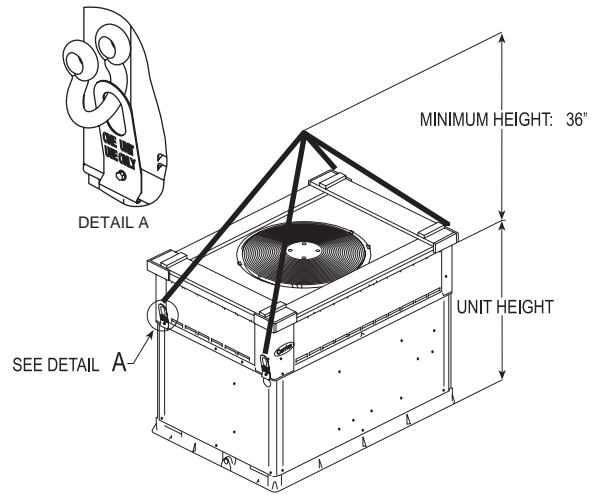
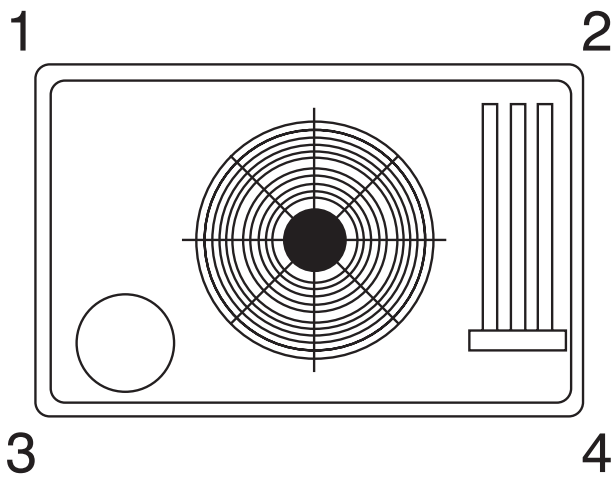

A07216

A05161

CORNER WEIGHTS (SMALL CABINET)									CORNER WEIGHTS (LARGE CABINET)						
Unit	018		024		030		036		Unit	042		048		060	
	lb	kg	lb	kg	lb	kg	lb	kg		Total Weight	lb	kg	lb	kg	lb
Total Weight	282	127.9	296	134.2	313	142.0	338	153.3	Total Weight	401	181.9	418	189.6	446	202.3
Corner Weight 1	73	33.1	59	26.8	55	25.1	72	32.5	Corner Weight 1	68	30.6	62	28.1	54	24.5
Corner Weight 2	60	27.4	84	38.0	95	42.9	89	40.3	Corner Weight 2	119	53.8	135	61.2	158	71.7
Corner Weight 3	95	43.0	81	36.8	78	35.2	95	43.0	Corner Weight 3	60	27.2	64	29.2	81	36.6
Corner Weight 4	54	24.4	72	32.6	85	38.7	83	37.5	Corner Weight 4	155	70.3	157	71.1	154	69.7
Rigging Weight	301	136.5	315	142.9	332	150.6	357	161.9	Rigging Weight	423	191.8	440	199.5	468	212.2
Shipping Weight	336	152.4	350	158.7	367	166.4	392	177.8	Shipping Weight	463	210.0	480	217.7	508	230.4

48ES

## SELECTION PROCEDURE (WITH EXAMPLE)

### 1. Determine cooling and heating requirements at design conditions:

Given:

Required Cooling Capacity (TC) . . . . . 34,000 Btuh  
 Sensible Heat Capacity (SHC) . . . . . 25,000 Btuh  
 Required Heating Capacity . . . . . 60,000 Btuh  
 Condenser Entering Air Temperature . . . . . 95°F  
 Indoor-Air Temperature . . . . . 80°F edb 67°F ewb  
 Evaporator Air Quantity . . . . . 1200 CFM  
 External Static Pressure . . . . . 0.100 in. wc  
 Electrical Characteristics . . . . . 208-1-60

### 2. Select unit based on required cooling capacity.

Enter Net Cooling Capacities table at condenser entering temperature of 95°F. Unit 036 at 1200 cfm and 67°F ewb (entering wet bulb) will provide a total capacity of 36,000 Btuh and a SHC of 27,400 Btuh. Calculate SHC correction, if required, using Note 4 under Cooling Capacities tables.

### 3. Select heating capacity of unit to provide design condition requirement.

In the Heating Capacities and Efficiencies table, note that the unit 036090 will provide 72,000 Btuh with an input of 90,000 Btuh.

### 4. Determine fan speed and power requirements at design conditions.

Before entering the air delivery tables, calculate the total static pressure required. From the given example, the Wet Coil Pressure Drop Table, and the Filter Pressure Drop Table:

External Static Pressure	0.100 in. wc
Filter	0.130 in. wc
Wet Coil Pressure Drop	<u>0.059 in. wc</u>
Total Static Pressure	0.289 in. wc

Enter the table for Dry Coil Air Delivery—horizontal and down-flow Discharge. For 208v operation, deduct 10% from the value given. At 0.33 ESP (external static pressure), the fan will deliver 1404 cfm at medium speed. The fan speed should be set at medium speed.

### 5. Select unit that corresponds to power source available.

The Electrical Data Table shows that the unit is designed to operate at 208-1-60.

# PERFORMANCE DATA

48ES018

EVAPORATOR AIR		CONDENSER ENTERING AIR TEMPERATURES deg F (C )																	
CFM / BF	EWB	75 (23.9)			85 (29.4)			95 (35.0)			105 (40.6)			115 (46.1)			125 (51.7)		
		Capacity MBtuh		Total System KW	Capacity MBtuh		Total System KW	Capacity MBtuh		Total System KW	Capacity MBtuh		Total System KW	Capacity MBtuh		Total System KW	Capacity MBtuh		Total System KW
		Total	Sens	Total	Sens	Total	Sens	Total	Sens	Total	Sens	Total	Sens	Total	Sens	Total	Sens	Total	Sens
	57	16.99	16.99	1.34	16.32	16.32	1.48	15.62	15.62	1.65	14.87	14.87	1.83	14.06	14.06	2.03	13.18	13.18	2.24
525 / 0.003	62	17.60	16.01	1.33	16.77	15.60	1.48	15.89	15.18	1.65	14.97	14.73	1.83	14.06	14.06	2.03	13.18	13.18	2.24
	63	17.97	12.99	1.33	17.12	12.59	1.48	16.22	12.19	1.63	15.28	11.75	1.83	14.25	11.30	2.03	13.16	10.81	2.24
	67	19.35	13.43	1.33	18.45	13.04	1.48	17.51	12.63	1.65	16.49	12.21	1.83	15.41	11.75	2.03	14.25	11.28	2.24
600 / 0.006	72	21.27	10.85	1.33	20.30	10.47	1.48	19.28	10.08	1.64	18.19	9.66	1.83	17.03	9.23	2.02	15.78	8.76	2.24
	57	17.74	17.74	1.36	17.03	17.03	1.51	16.28	16.28	1.67	15.48	15.48	1.85	14.62	14.62	2.05	13.69	13.69	2.26
	62	18.01	17.26	1.36	17.15	16.83	1.51	16.28	16.28	1.67	15.49	15.49	1.85	14.62	14.62	2.05	13.69	13.69	2.26
675 / 0.010	63	18.37	13.63	1.36	17.46	13.43	1.51	16.54	13.01	1.67	15.55	12.57	1.85	14.49	12.11	2.05	13.36	11.62	2.27
	67	19.77	14.33	1.36	18.83	13.93	1.51	17.84	13.51	1.67	16.78	13.08	1.85	15.66	12.62	2.05	14.46	12.13	2.26
	72	21.71	11.39	1.35	20.70	11.01	1.50	19.63	10.61	1.67	18.50	10.19	1.85	17.29	9.75	2.05	16.00	9.28	2.27
72	57	18.37	18.37	1.38	17.63	17.63	1.53	16.84	16.84	1.70	15.99	15.99	1.88	15.09	15.09	2.08	14.10	14.10	2.29
	62	18.37	18.37	1.38	17.63	17.63	1.53	16.84	16.84	1.70	15.99	15.99	1.88	15.09	15.09	2.08	14.10	14.10	2.29
	63	18.67	14.65	1.38	17.75	14.24	1.53	16.78	13.82	1.70	15.76	13.37	1.88	14.67	12.90	2.08	13.51	12.39	2.29
72	67	20.08	15.20	1.38	19.11	14.79	1.53	18.08	14.37	1.70	17.00	13.93	1.88	15.84	13.46	2.08	14.61	12.97	2.29
	72	22.04	11.92	1.38	20.99	11.53	1.53	19.89	11.12	1.69	18.72	10.70	1.88	17.48	10.25	2.08	16.15	9.78	2.29

48ES024

EVAPORATOR AIR		CONDENSER ENTERING AIR TEMPERATURES deg F (C )																	
CFM / BF	EWB	75 (23.9)			85 (29.4)			95 (35.0)			105 (40.6)			115 (46.1)			125 (51.7)		
		Capacity MBtuh		Total System KW	Capacity MBtuh		Total System KW	Capacity MBtuh		Total System KW	Capacity MBtuh		Total System KW	Capacity MBtuh		Total System KW	Capacity MBtuh		Total System KW
		Total	Sens	Total	Sens	Total	Sens	Total	Sens	Total	Sens	Total	Sens	Total	Sens	Total	Sens	Total	Sens
	57	22.08	22.08	1.62	21.24	21.24	1.81	20.35	20.35	2.01	19.40	19.40	2.24	18.38	18.38	2.49	17.26	17.26	2.76
700 / 0.004	62	22.78	19.89	1.62	21.71	19.41	1.81	20.59	18.91	2.01	19.43	19.35	2.24	18.38	18.38	2.49	17.26	17.26	2.76
	63	23.26	16.29	1.62	22.16	15.82	1.81	21.00	15.33	2.01	19.77	14.82	2.24	18.48	14.29	2.49	17.10	13.73	2.76
	67	25.03	16.83	1.62	23.84	16.36	1.81	22.60	15.87	2.01	21.29	15.36	2.24	19.91	14.83	2.49	18.43	14.27	2.76
800 / 0.007	72	27.53	13.73	1.62	26.23	13.26	1.81	24.86	12.78	2.01	23.43	12.27	2.24	21.92	11.75	2.49	20.29	11.20	2.76
	62	23.08	23.08	1.66	22.17	22.17	1.85	21.21	21.21	2.05	20.18	20.18	2.28	19.09	19.09	2.53	17.89	17.89	2.80
	63	23.33	21.47	1.66	22.23	22.07	1.85	21.21	21.21	2.05	20.18	20.18	2.28	19.08	19.08	2.53	17.89	17.89	2.80
900 / 0.011	63	23.76	17.40	1.66	22.60	16.91	1.85	21.38	16.41	2.05	20.10	15.89	2.28	18.76	15.35	2.53	17.33	14.77	2.80
	67	25.55	16.00	1.66	24.30	17.32	1.85	23.00	17.02	2.05	21.63	16.50	2.28	20.19	15.96	2.53	18.66	15.39	2.80
	72	28.08	14.47	1.66	26.72	14.00	1.85	25.28	13.50	2.06	23.79	12.98	2.28	22.21	12.45	2.53	20.52	11.89	2.80
72	57	23.91	23.91	1.70	22.94	22.94	1.89	21.92	21.92	2.09	20.83	20.83	2.32	19.66	19.66	2.57	18.40	18.40	2.84
	62	23.91	23.91	1.70	22.94	22.94	1.89	21.92	21.92	2.09	20.83	20.83	2.32	19.66	19.66	2.57	18.40	18.40	2.84
	63	24.13	18.47	1.70	22.92	17.97	1.89	21.66	17.46	2.09	20.35	16.92	2.32	18.96	16.37	2.57	17.50	15.77	2.84
72	67	25.93	19.14	1.70	24.64	18.65	1.89	23.29	18.14	2.09	21.88	17.61	2.32	20.40	17.05	2.57	18.82	16.46	2.84
	72	28.49	15.19	1.70	27.07	14.70	1.89	25.59	14.19	2.10	24.04	13.67	2.32	22.41	13.13	2.57	20.67	12.56	2.84



# PERFORMANCE DATA (CONT)

48ES030

EVAPORATOR AIR		CONDENSER ENTERING AIR TEMPERATURES deg F (C)																		
		75 (23.9)			85 (29.4)			95 (35.0)			105 (40.6)			115 (46.1)			125 (51.7)			
		CFM / BF	EWB	Total System KW	Capacity MBtuh	Sens	Total System KW	Capacity MBtuh	Sens	Total System KW	Capacity MBtuh	Sens	Total System KW	Capacity MBtuh	Sens	Total System KW	Capacity MBtuh	Sens	Total System KW	
	57	27.63	2.04	26.49	28.49	2.25	25.27	2.49	23.94	23.94	2.74	22.50	22.50	3.01	20.94	20.94	3.31	19.49	19.49	3.58
	62	28.17	2.04	26.78	24.51	2.25	25.33	2.49	23.94	23.94	2.74	22.50	22.50	3.01	20.94	20.94	3.31	19.49	19.49	3.58
<b>875 / 0.009</b>	63	28.67	2.04	27.24	19.59	2.25	25.71	18.94	24.08	18.25	2.74	22.34	17.53	3.01	20.49	16.76	3.30	18.26	16.76	3.57
	67	30.82	2.05	29.28	20.29	2.26	27.63	2.49	25.87	18.95	2.75	23.99	18.22	3.02	21.99	17.45	3.31	16.22	17.45	3.58
	72	33.80	16.64	32.10	16.03	2.27	30.28	15.38	20.36	14.71	2.75	26.28	13.98	3.03	24.08	13.23	3.32	21.54	13.23	3.59
<b>1000 / 0.013</b>	57	28.69	2.09	27.47	27.47	2.31	26.16	26.16	24.74	24.74	2.79	23.21	23.21	3.07	21.54	21.54	3.36	20.00	21.54	3.63
	62	28.77	2.09	27.47	27.47	2.31	26.16	26.16	24.74	24.74	2.79	23.21	23.21	3.07	21.54	21.54	3.36	20.00	21.54	3.63
	63	29.16	2.15	27.67	20.88	2.31	26.07	20.22	24.38	19.51	2.79	22.58	18.77	3.07	20.68	17.98	3.36	18.77	17.98	3.63
	67	31.33	2.10	29.72	21.67	2.31	28.00	21.00	26.18	20.30	2.80	24.24	19.55	3.07	22.17	18.76	3.36	17.45	18.76	3.63
	72	34.34	17.47	32.57	16.84	2.32	30.67	16.18	25.55	15.50	2.81	26.52	14.77	3.08	24.25	14.00	3.37	21.54	14.00	3.64
<b>1125 / 0.019</b>	57	29.57	2.15	28.28	28.28	2.36	26.88	26.88	25.39	25.39	2.85	23.77	23.77	3.12	22.01	22.01	3.42	20.50	22.01	3.69
	62	29.56	2.15	28.27	28.27	2.36	26.88	26.88	25.39	25.39	2.85	23.77	23.77	3.12	22.01	22.01	3.42	20.50	22.01	3.69
	63	29.52	2.15	27.98	22.13	2.36	26.34	21.44	24.60	20.72	2.85	22.76	19.95	3.12	20.82	19.11	3.41	18.22	19.11	3.68
	67	31.70	23.65	30.03	23.00	2.36	28.26	22.32	26.40	21.60	2.85	24.41	20.83	3.13	22.30	20.00	3.42	18.76	20.00	3.69
	72	34.73	18.26	32.90	17.63	2.37	30.94	16.96	28.89	16.27	2.86	26.67	15.53	3.13	24.34	14.76	3.42	18.76	14.76	3.69

48ES036

EVAPORATOR AIR		CONDENSER ENTERING AIR TEMPERATURES deg F (C)																				
		75 (23.9)			85 (29.4)			95 (35.0)			105 (40.6)			115 (46.1)			125 (51.7)					
		CFM / BF	EWB	Total System KW	Capacity MBtuh	Sens	Total System KW	Capacity MBtuh	Sens	Total System KW	Capacity MBtuh	Sens	Total System KW	Capacity MBtuh	Sens	Total System KW	Capacity MBtuh	Sens	Total System KW			
	57	32.76	32.76	2.31	31.53	31.53	30.22	30.22	2.84	28.82	28.82	3.15	27.30	27.30	3.48	25.63	25.63	3.85	24.18	24.18	4.12	
	62	33.56	29.11	2.31	32.01	28.44	2.56	30.39	27.73	2.84	28.82	28.82	3.15	27.30	27.30	3.48	25.63	25.63	3.85	24.18	24.18	4.12
<b>1050 / 0.002</b>	63	34.27	23.75	2.31	32.67	23.09	2.56	30.98	22.40	2.84	29.20	21.68	3.15	27.28	20.92	3.48	25.21	20.11	3.85	18.22	18.22	4.09
	67	36.87	24.54	2.31	35.16	23.89	2.57	33.36	23.20	2.85	31.45	22.49	3.15	29.40	21.73	3.49	27.19	20.92	3.85	16.22	16.22	4.06
	72	40.54	19.93	2.32	38.69	19.28	2.58	36.71	18.60	2.85	34.62	17.89	3.16	32.38	17.14	3.50	29.97	16.34	3.86	14.22	14.22	3.99
<b>1200 / 0.004</b>	57	34.22	34.22	2.36	32.89	32.89	2.62	31.49	31.49	2.90	29.98	29.98	3.20	28.34	28.34	3.54	26.55	26.55	3.91	24.54	24.54	4.22
	62	34.37	31.46	2.36	32.89	32.89	2.62	31.49	31.49	2.90	29.98	29.98	3.20	28.34	28.34	3.54	26.55	26.55	3.91	22.54	22.54	4.19
	63	34.97	25.40	2.37	33.30	24.72	2.62	31.54	24.02	2.90	29.68	23.28	3.20	27.69	22.50	3.54	25.55	21.67	3.90	18.22	18.22	4.16
	67	37.61	26.29	2.37	35.82	25.62	2.62	34.00	24.93	2.90	31.94	24.19	3.21	29.81	23.42	3.54	27.53	22.59	3.91	16.22	16.22	4.13
	72	41.33	21.04	2.38	39.38	20.37	2.63	37.31	19.68	2.91	35.13	18.95	3.22	32.80	18.19	3.55	30.30	17.38	3.91	14.22	14.22	4.10
<b>1350 / 0.008</b>	57	35.44	35.44	2.42	34.03	34.03	2.68	32.53	32.53	2.95	30.93	30.93	3.26	29.20	29.20	3.60	27.30	27.30	3.96	25.21	25.21	4.29
	62	35.44	35.44	2.42	34.03	34.03	2.68	32.53	32.53	2.95	30.93	30.93	3.26	29.20	29.20	3.60	27.30	27.30	3.96	23.21	23.21	4.26
	63	35.50	26.99	2.42	33.77	26.30	2.68	31.95	25.59	2.95	30.03	24.83	3.26	27.98	24.03	3.60	25.80	23.16	3.96	21.22	21.22	4.23
	67	38.16	27.99	2.43	36.31	27.31	2.68	34.36	26.60	2.96	32.30	25.85	3.27	30.11	25.06	3.60	27.77	24.21	3.96	18.22	18.22	4.20
	72	41.91	22.10	2.44	39.89	21.42	2.69	37.74	20.71	2.97	35.48	19.98	3.27	33.09	19.21	3.61	30.51	18.39	3.97	16.22	16.22	4.17

# PERFORMANCE DATA (CONT)

48ES042

EVAPORATOR AIR		CONDENSER ENTERING AIR TEMPERATURES deg F (C)																	
		75 (23.9)			85 (29.4)			95 (35.0)			105 (40.6)			115 (46.1)			125 (51.7)		
		CFM / BF	EWB	Total System KW	Capacity MBtuh	Total System KW	Capacity MBtuh	Total System KW	Capacity MBtuh	Total System KW	Capacity MBtuh	Total System KW	Capacity MBtuh	Total System KW	Capacity MBtuh	Total System KW	Capacity MBtuh	Total System KW	
			Total	Sens	Total	Sens	Total	Sens	Total	Sens	Total	Sens	Total	Sens	Total	Sens	Total		
	57	39.26	39.26	2.88	37.83	37.83	3.20	35.88	35.88	3.55	34.00	34.00	3.94	31.96	31.96	4.35	29.76	29.76	4.80
	62	40.35	36.68	2.89	38.34	35.70	3.21	36.22	34.84	3.56	34.03	33.95	3.94	31.96	31.96	4.35	29.76	29.76	4.80
	63	41.07	29.58	2.90	39.00	28.64	3.22	36.79	27.65	3.56	34.46	26.62	3.94	31.99	25.54	4.35	29.39	24.41	4.79
	67	44.14	30.58	2.93	41.87	29.62	3.24	39.47	28.82	3.59	36.94	27.57	3.97	34.25	26.48	4.37	31.44	25.34	4.81
	72	48.32	24.44	2.96	45.81	23.49	3.28	43.17	22.50	3.83	40.38	21.47	4.00	37.41	20.39	4.41	34.32	19.28	4.84
	57	40.77	40.77	2.97	39.02	39.02	3.29	37.13	37.13	3.64	35.10	35.10	4.02	32.92	32.92	4.44	30.58	30.58	4.88
	62	41.18	39.33	2.98	39.13	38.61	3.29	37.13	37.13	3.64	35.10	35.10	4.02	32.92	32.92	4.44	30.58	30.58	4.88
	63	41.80	31.43	2.98	39.62	30.46	3.30	37.31	29.45	3.64	34.89	28.39	4.02	32.32	27.28	4.43	29.64	26.11	4.87
	67	44.88	32.54	3.01	42.50	31.56	3.32	40.00	30.54	3.67	37.37	29.47	4.05	34.58	28.34	4.45	31.68	27.18	4.89
	72	49.11	25.59	3.05	46.48	24.62	3.36	43.73	23.62	3.71	40.83	22.57	4.08	37.75	21.47	4.49	34.56	20.35	4.92
	57	42.02	42.02	3.06	40.15	40.15	3.38	38.14	38.14	3.73	35.99	35.99	4.11	33.68	33.68	4.52	31.22	31.22	4.96
	62	42.02	42.02	3.06	40.14	40.14	3.38	38.14	38.14	3.73	35.99	35.99	4.11	33.68	33.68	4.52	31.22	31.22	4.96
	63	42.32	33.20	3.06	40.06	32.21	3.38	37.66	31.17	3.72	35.19	30.08	4.10	32.55	28.93	4.51	29.81	27.71	4.95
	67	45.41	34.43	3.09	42.95	33.43	3.40	40.37	32.39	3.75	37.66	31.29	4.12	34.80	30.13	4.53	31.84	28.92	4.97
	72	49.67	26.70	3.13	46.95	25.71	3.44	44.12	24.70	3.79	41.12	23.64	4.16	37.96	22.53	4.56	34.69	21.39	5.00

48ES048

EVAPORATOR AIR		CONDENSER ENTERING AIR TEMPERATURES deg F (C)																	
		75 (23.9)			85 (29.4)			95 (35.0)			105 (40.6)			115 (46.1)			125 (51.7)		
		CFM / BF	EWB	Total System KW	Capacity MBtuh	Total System KW	Capacity MBtuh	Total System KW	Capacity MBtuh	Total System KW	Capacity MBtuh	Total System KW	Capacity MBtuh	Total System KW	Capacity MBtuh	Total System KW	Capacity MBtuh	Total System KW	
			Total	Sens	Total	Sens	Total	Sens	Total	Sens	Total	Sens	Total	Sens	Total	Sens	Total		
	57	46.24	46.24	3.34	44.25	44.25	3.75	42.10	42.10	4.20	39.79	39.79	4.69	37.27	37.27	5.21	34.57	34.57	5.77
	62	47.38	41.31	3.34	44.96	40.19	3.75	42.39	38.97	4.20	39.78	39.78	4.69	37.27	37.27	5.21	34.57	34.57	5.77
	63	48.22	33.26	3.35	45.72	32.19	3.76	43.06	31.05	4.20	40.24	29.86	4.69	37.23	28.61	5.21	34.06	27.31	5.77
	67	51.54	34.27	3.36	48.83	33.18	3.77	45.97	32.05	4.22	42.91	30.85	4.70	39.67	29.60	5.22	36.28	28.30	5.77
	72	56.08	27.21	3.37	53.10	26.13	3.78	49.97	25.02	4.23	46.62	23.85	4.71	43.09	22.63	5.23	39.41	21.38	5.78
	57	47.90	47.90	3.43	45.77	45.77	3.84	43.47	43.47	4.29	40.98	40.98	4.77	38.30	38.30	5.29	35.44	35.44	5.85
	62	48.26	44.29	3.43	45.60	45.74	3.84	43.46	43.46	4.29	40.98	40.98	4.77	38.30	38.30	5.29	35.44	35.44	5.85
	63	48.98	35.32	3.43	46.37	34.22	3.84	43.61	33.07	4.29	40.67	31.85	4.77	37.96	30.57	5.29	34.30	29.23	5.85
	67	52.30	36.46	3.44	49.48	35.36	3.85	46.50	34.20	4.30	43.33	32.98	4.78	39.99	31.70	5.30	36.50	30.37	5.86
	72	56.88	28.48	3.46	53.77	27.39	3.87	50.52	26.26	4.31	47.05	25.07	4.79	43.40	23.84	5.31	39.62	22.58	5.86
	57	49.26	49.26	3.51	46.99	46.99	3.93	44.56	44.56	4.37	41.93	41.93	4.86	39.11	39.11	5.38	36.11	36.11	5.94
	62	49.26	49.26	3.51	46.99	46.99	3.93	44.56	44.56	4.37	41.93	41.93	4.86	39.11	39.11	5.38	36.11	36.11	5.94
	63	49.52	37.31	3.52	46.82	36.18	3.93	43.98	35.00	4.37	40.96	33.76	4.86	37.78	32.44	5.38	34.46	31.03	5.93
	67	52.84	38.59	3.53	49.92	37.46	3.94	46.86	36.28	4.38	43.60	35.04	4.87	40.18	33.72	5.38	36.63	32.34	5.94
	72	57.43	29.71	3.54	54.22	26.61	3.95	50.88	27.47	4.40	47.31	26.27	4.88	43.58	25.03	5.39	39.71	23.76	5.94



# PERFORMANCE DATA (CONT)

48ES060

EVAPORATOR AIR		CONDENSER ENTERING AIR TEMPERATURES deg F (C)																							
		75 (23.9)				85 (29.4)				95 (35.0)				105 (40.6)				115 (46.1)				125 (51.7)			
CFM / BF	EWB	Capacity MBtuh		Total System KW	Capacity MBtuh		Total System KW	Capacity MBtuh		Total System KW	Capacity MBtuh		Total System KW	Capacity MBtuh		Total System KW	Capacity MBtuh		Total System KW	Capacity MBtuh		Total System KW			
		Total	Sens		Total	Sens		Total	Sens		Total	Sens		Total	Sens		Total	Sens		Total	Sens		Total	Sens	Total
	57	57.18	57.18	4.12	54.74	54.74	4.57	52.17	52.17	5.08	49.44	49.44	5.62	46.49	46.49	6.21	43.26	43.26	6.85	40.26	40.26	7.49	37.10	37.10	
	62	58.24	58.24	4.13	55.28	55.28	4.58	52.26	52.26	5.08	49.44	49.44	5.62	46.49	46.49	6.21	43.26	43.26	6.85	40.26	40.26	7.49	37.10	37.10	
<b>1750 / 0.010</b>	63	59.21	43.22	4.14	56.15	41.90	4.59	52.95	40.53	5.08	49.60	39.12	5.62	46.07	37.65	6.21	42.28	36.10	6.84	38.93	38.93	7.61	34.86	34.86	
	67	63.23	44.50	4.18	59.93	43.17	4.63	56.50	41.81	5.13	52.90	40.40	5.67	48.09	38.93	6.25	45.01	37.38	6.87	36.27	36.27	8.18	32.73	32.73	
	72	68.86	35.81	4.24	65.24	34.48	4.69	61.48	31.73	5.19	57.53	31.73	5.72	53.35	30.27	6.30	48.86	28.73	6.92	28.73	28.73	8.18	26.60	26.60	
<b>2000 / 0.016</b>	57	58.38	59.38	4.25	56.75	56.75	4.70	53.98	53.98	5.21	51.04	51.04	5.75	47.89	47.89	6.34	44.43	44.43	6.97	41.87	41.87	7.61	37.10	37.10	
	62	59.48	57.25	4.25	56.75	56.75	4.70	53.98	53.98	5.21	51.04	51.04	5.75	47.89	47.89	6.34	44.43	44.43	6.97	41.87	41.87	7.61	37.10	37.10	
	63	60.17	46.05	4.25	56.97	44.70	4.70	53.64	43.31	5.20	50.17	41.87	5.74	46.52	40.37	6.32	42.63	38.78	6.95	38.78	38.78	8.18	34.86	34.86	
	67	64.20	47.51	4.29	60.76	46.16	4.75	57.19	44.78	5.24	53.46	43.34	5.78	49.53	41.85	6.36	45.33	40.26	6.98	40.26	40.26	8.18	34.86	34.86	
	72	69.84	37.64	4.35	66.07	36.31	4.81	62.17	34.94	5.30	58.07	33.52	5.84	53.75	32.04	6.41	49.12	30.48	7.03	30.48	30.48	8.18	34.86	34.86	
<b>2250 / 0.022</b>	57	61.17	61.17	4.37	58.37	58.37	4.83	55.44	55.44	5.33	52.32	52.32	5.86	48.98	48.98	6.46	45.33	45.33	7.09	45.33	45.33	8.18	34.86	34.86	
	62	61.16	61.16	4.37	58.37	58.37	4.83	55.43	55.43	5.33	52.32	52.32	5.86	48.98	48.98	6.46	45.33	45.33	7.09	45.33	45.33	8.18	34.86	34.86	
	63	60.89	48.82	4.37	57.57	47.44	4.82	54.15	46.02	5.31	50.59	44.55	5.85	46.85	43.00	6.43	42.92	41.27	7.06	41.27	41.27	8.18	34.86	34.86	
	67	64.91	50.45	4.41	61.36	49.08	4.86	57.69	47.87	5.36	53.86	46.21	5.89	49.84	44.67	6.47	45.58	43.00	7.09	43.00	43.00	8.18	34.86	34.86	
	72	70.53	39.43	4.47	66.85	38.07	4.92	62.63	36.69	5.42	58.41	35.26	5.95	53.97	33.76	6.52	49.23	32.19	7.14	32.19	32.19	8.18	34.86	34.86	

**LEGEND**

- BF — Bypass Factor
- edb — Entering Dry – Bulb
- Ewb — Entering Wet – Bulb
- KW — Total Unit Power Input
- SHC — Sensible Heat Capacity (1000 Btuh)
- TC — Total Capacity (1000 Btuh) (net)
- rh — Relative Humidity

**COOLING NOTES:**

1. Ratings are net; they account for the effects of the evaporator – fan motor power and heat.
2. Direct interpolation is permissible. Do not extrapolate.
3. The following formulas may be used:

$$t_{db} = t_{edb} - \frac{\text{Sensible capacity (Btuh)}}{1.10 \times \text{cfm}}$$

$$t_{wb} = \text{Wet-bulb temperature corresponding to enthalpy air leaving evaporator coil (} h_{lwb} \text{)}$$

Where:  $h_{wb}$  = Enthalpy of air entering evaporator coil

4. The SHC is based on 80° F (26.6°C) edb temperature of air entering evaporator coil. Below 80° F (26.6°C) edb, subtract (corr factor x cfm) from SHC.

Above 80° F (26.6°C) edb, add (corr factor x cfm) to SHC.

Correction Factor =  $1.10 \times (1 + BF) \times (edb + 80)$ .

5. Integrated capacity is maximum (instantaneous) capacity less the effect of frost on the outdoor coil and the heat required to defrost it.

# PERFORMANCE DATA (CONT)

## Dry Coil Air Delivery\* - Horizontal and Downflow Discharge - Unit 48ES024-036 (Deduct 10% for 208 Volts)

Unit	Heating Rise Range °F	Motor Speed		External Static Pressure (in. wc)								
				0.1	0.2	0.3	0.4	0.5	0.6	0.7	0.8	0.9
48ES(-,N)018040	30 – 60	Low <sup>1</sup>	Watts	260	243	229	217	209	--	--	--	--
			CFM	859	775	667	536	382	--	--	--	--
			Heating Rise °F	35	39	45	56	NA	NA	NA	NA	NA
		High	Watts	340	328	317	307	300	294	--	--	--
			CFM	1064	948	820	680	528	364	--	--	--
			Heating Rise °F	NA	32	37	44	57	NA	NA	NA	NA
48ES(-,N)024040	20 – 50	Low <sup>1</sup>	Watts	311	309	304	301	286	290	286	280	--
			CFM	935	885	820	757	686	583	423	263	--
			Heating Rise °F	32	34	37	40	44	NA	NA	NA	NA
		Medium	Watts	411	405	398	390	379	357	357	345	327
			CFM	1195	1155	1100	1028	957	868	769	647	365
			Heating Rise °F	25	26	27	29	31	35	39	46	NA
		High	Watts	528	518	509	492	477	467	447	435	421
			CFM	1484	1421	1368	1279	1185	1088	970	853	712
			Heating Rise °F	20	21	22	23	25	28	31	35	42
48ES(-,N)024060	35 – 65	Low <sup>1</sup>	Watts	311	309	304	301	286	290	286	280	--
			CFM	935	885	820	757	686	583	423	263	--
			Heating Rise °F	48	51	55	59	NA	NA	NA	NA	NA
		Medium	Watts	411	405	398	390	379	357	357	345	327
			CFM	1195	1155	1100	1028	957	868	769	647	365
			Heating Rise °F	38	39	41	44	47	52	59	NA	NA
		High	Watts	528	518	509	492	477	467	447	435	421
			CFM	1484	1421	1368	1279	1185	1088	970	853	712
			Heating Rise °F	NA	NA	NA	35	38	41	46	53	63
48ES(-,N)030040	20 – 50	Low	Watts	311	309	304	301	286	290	286	280	--
			CFM	935	885	820	757	686	583	423	263	--
			Heating Rise °F	32	34	37	40	44	NA	NA	NA	NA
		Medium <sup>1</sup>	Watts	411	405	398	390	379	357	357	345	327
			CFM	1195	1155	1100	1028	957	868	769	647	365
			Heating Rise °F	25	26	27	29	31	35	39	46	NA
		High	Watts	528	518	509	492	477	467	447	435	421
			CFM	1484	1421	1368	1279	1185	1088	970	853	712
			Heating Rise °F	20	21	22	23	25	28	31	35	42
48ES(-,N)030060	35 – 65	Low	Watts	311	309	304	301	286	290	286	280	--
			CFM	935	885	820	757	686	583	423	263	--
			Heating Rise °F	48	51	55	59	NA	NA	NA	NA	NA
		Medium <sup>1</sup>	Watts	411	405	398	390	379	357	357	345	327
			CFM	1195	1155	1100	1028	957	868	769	647	365
			Heating Rise °F	38	39	41	44	47	52	59	NA	NA
		High	Watts	528	518	509	492	477	467	447	435	421
			CFM	1484	1421	1368	1279	1185	1088	970	853	712
			Heating Rise °F	NA	NA	NA	35	38	41	46	53	63
48ES(-,N)036060	25 – 55	Low <sup>1</sup>	Watts	439	429	415	401	395	380	356	339	329
			CFM	1242	1170	1089	994	917	837	702	570	442
			Heating Rise °F	36	38	41	45	49	54	NA	NA	NA
		Medium	Watts	503	491	479	461	450	436	418	404	389
			CFM	1320	1244	1162	1081	1005	897	767	662	541
			Heating Rise °F	34	36	39	42	45	50	NA	NA	NA
		High	Watts	641	627	623	609	601	588	571	559	548
			CFM	1362	1288	1205	1119	1033	933	826	714	580
			Heating Rise °F	33	35	37	40	44	48	54	NA	NA
48ES(-,N)036090	40 – 70	Low <sup>1</sup>	Watts	439	429	415	401	395	380	356	339	329
			CFM	1242	1170	1089	994	917	837	702	570	442
			Heating Rise °F	54	58	62	68	NA	NA	NA	NA	NA
		Medium	Watts	503	491	479	461	450	436	418	404	389
			CFM	1320	1244	1162	1081	1005	897	767	662	541
			Heating Rise °F	51	54	58	62	67	NA	NA	NA	NA
		High	Watts	641	627	623	609	601	588	571	559	548
			CFM	1362	1288	1205	1119	1033	933	826	714	580
			Heating Rise °F	50	52	56	60	65	NA	NA	NA	NA

48ES

# PERFORMANCE DATA (CONT)

## Dry Coil Air Delivery\* - Horizontal and Downflow Discharge - Unit 48ES042-060 (Deduct 10% for 208 Volts)

Unit	Heating Rise Range °F	Motor Speed	External Static Pressure (in. wc)									
			0.1	0.2	0.3	0.4	0.5	0.6	0.7	0.8	0.9	
48ES(-,N)042060	25 – 55	Low <sup>1</sup>	Watts	559	540	522	503	483	464	445	425	406
			CFM	1405	1370	1330	1283	1230	1171	1106	1034	957
			Heating Rise °F	32	33	34	35	37	38	41	44	47
		Medium	Watts	665	647	629	609	589	567	545	521	497
			CFM	1593	1552	1505	1452	1394	1330	1260	1184	1102
			Heating Rise °F	28	29	30	31	32	34	36	38	41
		High	Watts	815	795	775	754	734	715	695	676	656
			CFM	1764	1710	1652	1591	1525	1456	1383	1306	1225
			Heating Rise °F	26	26	27	28	30	31	33	34	37
48ES(-,N)042090	40 – 70	Low <sup>1</sup>	Watts	559	540	522	503	483	464	445	425	406
			CFM	1405	1370	1330	1283	1230	1171	1106	1034	957
			Heating Rise °F	48	49	51	53	55	58	61	65	NA
		Medium	Watts	665	647	629	609	589	567	545	521	497
			CFM	1593	1552	1505	1452	1394	1330	1260	1184	1102
			Heating Rise °F	42	43	45	46	48	51	54	57	61
		High	Watts	815	795	775	754	734	715	695	676	656
			CFM	1764	1710	1652	1591	1525	1456	1383	1306	1225
			Heating Rise °F	NA	NA	41	42	44	46	49	52	55
48ES(-,N)048090	25 – 55	Low	Watts	627	617	607	584	567	548	528	503	480
			CFM	1550	1530	1493	1461	1414	1361	1320	1250	1177
			Heating Rise °F	44	44	45	46	48	50	51	54	NA
		Medium <sup>1</sup>	Watts	771	755	734	711	690	665	639	607	572
			CFM	1798	1771	1734	1687	1645	1595	1530	1449	1355
			Heating Rise °F	38	38	39	40	41	42	44	47	50
		High	Watts	969	941	908	887	858	827	804	767	748
			CFM	2124	2071	2000	1944	1876	1811	1735	1647	1555
			Heating Rise °F	32	33	34	35	36	37	39	41	43
48ES(-,N)048115	35 – 65	Low	Watts	627	617	607	584	567	548	528	503	480
			CFM	1550	1530	1493	1461	1414	1361	1320	1250	1177
			Heating Rise °F	56	56	58	59	61	63	65	NA	NA
		Medium <sup>1</sup>	Watts	771	755	734	711	690	665	639	607	572
			CFM	1798	1771	1734	1687	1645	1595	1530	1449	1355
			Heating Rise °F	48	49	50	51	52	54	56	60	64
		High	Watts	969	941	908	887	858	827	804	767	748
			CFM	2124	2071	2000	1944	1876	1811	1735	1647	1555
			Heating Rise °F	41	42	43	44	46	48	50	52	55
48ES(-,N)048130	40 – 70	Low	Watts	627	617	607	584	567	548	528	503	480
			CFM	1550	1530	1493	1461	1414	1361	1320	1250	1177
			Heating Rise °F	63	64	65	67	69	NA	NA	NA	NA
		Medium <sup>1</sup>	Watts	771	755	734	711	690	665	639	607	572
			CFM	1798	1771	1734	1687	1645	1595	1530	1449	1355
			Heating Rise °F	54	55	56	58	59	61	64	67	NA
		High	Watts	969	941	908	887	858	827	804	767	748
			CFM	2124	2071	2000	1944	1876	1811	1735	1647	1555
			Heating Rise °F	46	47	49	50	52	54	56	59	63
48ES(-,N)060090	25 – 55	Low <sup>1</sup>	Watts	786	769	754	736	722	705	684	658	616
			CFM	2027	1960	1901	1821	1759	1693	1616	1513	1354
			Heating Rise °F	33	34	36	37	38	40	42	45	50
		Medium	Watts	873	849	833	815	798	782	763	748	704
			CFM	2095	2026	1962	1887	1817	1748	1679	1583	1439
			Heating Rise °F	32	33	34	36	37	39	40	43	47
		High	Watts	1012	993	981	963	948	927	904	886	846
			CFM	2184	2109	2036	1963	1886	1812	1729	1647	1496
			Heating Rise °F	31	32	33	34	36	37	39	41	45
48ES(-,N)060115	35 – 65	Low <sup>1</sup>	Watts	786	769	754	736	722	705	684	658	616
			CFM	2027	1960	1901	1821	1759	1693	1616	1513	1354
			Heating Rise °F	43	44	45	47	49	51	53	57	64
		Medium	Watts	873	849	833	815	798	782	763	748	704
			CFM	2095	2026	1962	1887	1817	1748	1679	1583	1439
			Heating Rise °F	41	43	44	46	47	49	51	54	60
		High	Watts	1012	993	981	963	948	927	904	886	846
			CFM	2184	2109	2036	1963	1886	1812	1729	1647	1496
			Heating Rise °F	39	41	42	44	46	48	50	52	58
48ES(-,N)060130	40 – 70	Low <sup>1</sup>	Watts	786	769	754	736	722	705	684	658	616
			CFM	2027	1960	1901	1821	1759	1693	1616	1513	1354
			Heating Rise °F	48	50	51	54	55	58	60	64	NA
		Medium	Watts	873	849	833	815	798	782	763	748	704
			CFM	2095	2026	1962	1887	1817	1748	1679	1583	1439
			Heating Rise °F	47	48	50	52	54	56	58	62	68
		High	Watts	1012	993	981	963	948	927	904	886	846
			CFM	2184	2109	2036	1963	1886	1812	1729	1647	1496
			Heating Rise °F	45	46	48	50	52	54	56	59	65

\* Air delivery values are without air filter and are for dry coil (See Table 15 – 48ES Wet Coil Pressure Drop table).

<sup>1</sup> Factory-shipped heating/cooling speed

NA = Not allowed for heating speed

Note: Deduct field-supplied air filter pressure drop and wet coil pressure drop to obtain external static pressure available for ducting.

48ES

# PERFORMANCE DATA (CONT)

## Filter Pressure Drop Table (in. wc)

FILTER SIZE	CFM																			
	500	600	700	800	900	1000	1100	1200	1300	1400	1500	1600	1700	1800	1900	2000	2100	2200	2300	
20X20X1	0.05	0.07	0.08	0.1	0.12	0.13	0.14	0.15	—	—	—	—	—	—	—	—	—	—	—	
24X30X1	—	—	—	0.04	0.05	0.06	0.07	0.07	0.08	0.09	0.1	—	—	—	—	—	—	—	—	
24X36X1	—	—	—	—	—	—	—	0.06	0.07	0.07	0.08	0.09	0.09	0.10	0.11	0.12	0.13	0.14	0.14	

## 48ES Wet Coil Pressure Drop

UNIT SIZE	STANDARD CFM (S.C.F.M.)																
	500	600	700	800	900	1000	1100	1200	1300	1400	1500	1600	1700	1800	1900	2000	
018	0.011	0.013	0.018	0.022	-	-	-	-	-	-	-	-	-	-	-	-	
024	-	0.030	0.037	0.044	0.053	0.063	-	-	-	-	-	-	-	-	-	-	
030	-	-	0.037	0.044	0.053	0.063	0.072	0.081	0.105	-	-	-	-	-	-	-	
036	-	-	-	-	0.05	0.061	0.072	0.080	0.090	0.110	-	-	-	-	-	-	
042	-	-	-	-	-	0.044	0.051	0.059	0.065	0.072	0.080	0.088	0.095	0.105	-	-	
048	-	-	-	-	-	-	-	0.044	0.050	0.053	0.059	0.066	0.072	0.077	0.086	-	
060	-	-	-	-	-	-	-	-	-	-	-	0.079	0.087	0.095	0.102	0.113	0.123

## Economizer 1-in. Filter Pressure Drop (in. wc)

UNIT 48ES	PRESSURE DROP
018-036	0.20
042-060	0.25

## HIGH ALTITUDE COMPENSATION

### NATURAL GAS ONLY

#### ORIFICE CONVERSION—3.5 IN. WC MANIFOLD PRESSURE\*

ALTITUDE (ft)	INPUT (Btuh)	ORIFICE NUMBER†
0-2000	40,000	#44
	60,000	#38
	90,000	#38
	115,000	#33
	130,000	#31
2001-4500	32,800	#48
	49,200	#42
	73,800	#42
	94,300	#36
	106,600	#33

\*As the height above sea level increases, there is less oxygen per cubic ft of air. Therefore, heat input rate should be reduced at higher altitudes.

†Orifices available through your distributor.

### PROPANE GAS ONLY

#### ORIFICE CONVERSION—3.5 IN. WC MANIFOLD PRESSURE\*

ALTITUDE (ft)	INPUT (Btuh)	ORIFICE NUMBER†
0-2000	40,000	#50
	57,000	#46
	85,500	#46
	115,000	#42
	127,000	#41
2001-6000	31,200	#52
	46,800	#48
	70,200	#48
	89,700	#44
	101,400	#43

\*As the height above sea level increases, there is less oxygen per cubic ft of air. Therefore, heat input rate should be reduced at higher altitudes.

†Orifices available through your distributor.

48ES

# TYPICAL PIPING AND WIRING

48ES

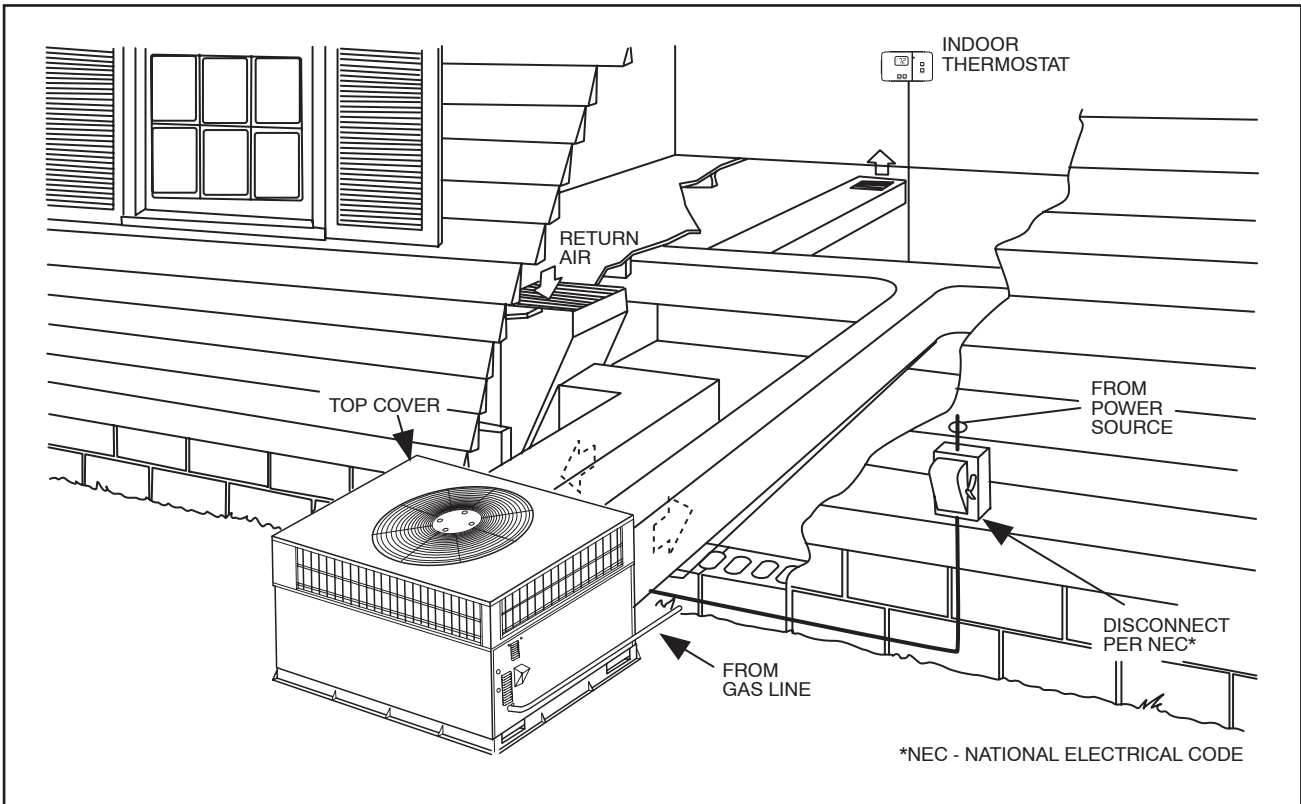
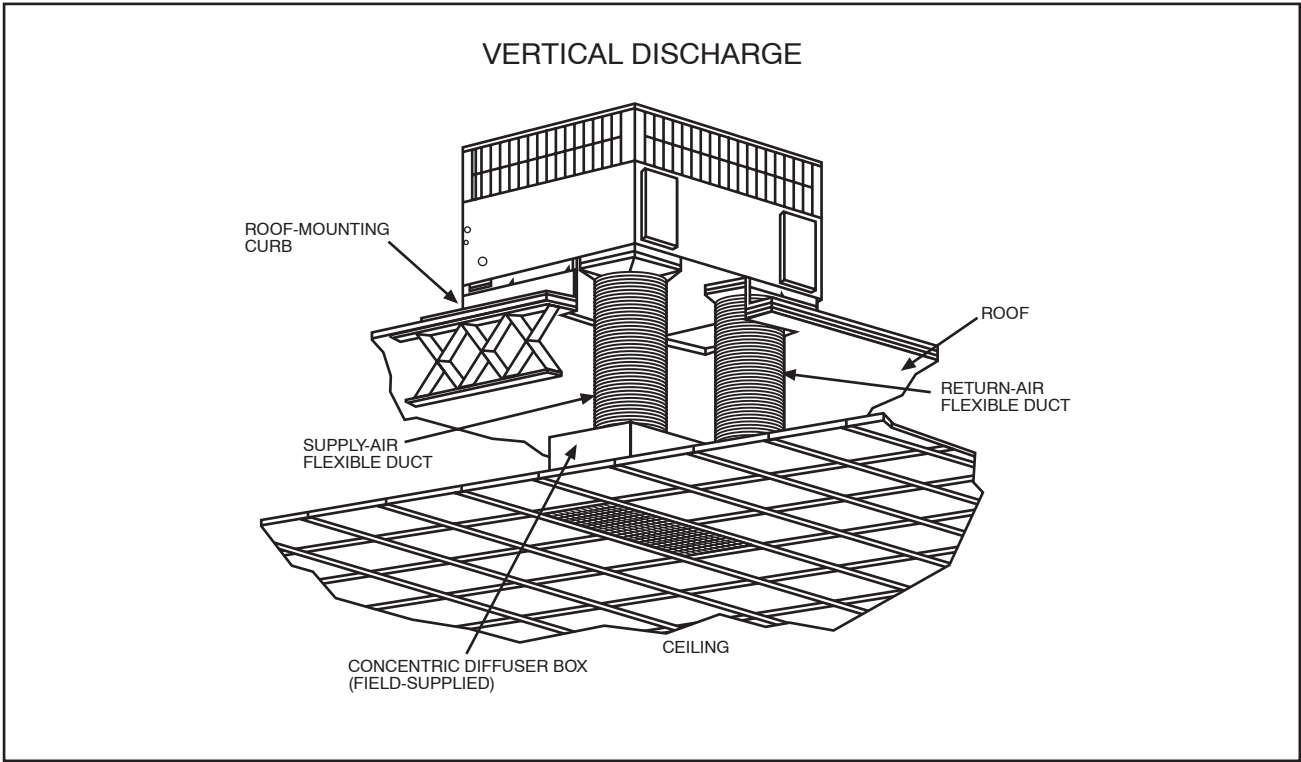

## APPLICATION DATA

**Condensate trap** — A 2-in. condensate trap must be field supplied.

**Ductwork** — Secure downflow discharge ductwork to roof curb. For horizontal discharge applications, attach ductwork to unit with flanges.

**To convert a unit to downflow discharge** — Units are equipped with factory-installed inserts in the down-flow openings. Removal of the inserts is similar to removing an electrical knock-out. Use the duct cover to seal the horizontal discharge openings in the unit. Units installed in horizontal discharge orientation do not require duct covers.

**Airflow** — Units are draw-thru in the cooling mode and blow-thru in the heating mode.

**Maximum cooling airflow** — To minimize the possibility of condensate blow-off from the evaporator, airflow through the units should not exceed 450 cfm per ton.

**Minimum cooling airflow** — Minimum cooling airflow is 350 cfm per ton.

**Minimum ambient cooling operation temperature** — All standard units have a minimum ambient operating temperature of 40°F (4°C). With accessory low ambient temperature kit, units can operate at temperatures down to 0°F (-17°C).

**Minimum temperature** — Air entering the heat exchanger in heating mode must be a minimum of 50°F (10°C) continuous and/or 45°F (7°C) intermittent.

# ELECTRICAL DATA

UNIT	NOMINAL V-PH-HZ	VOLTAGE RANGE		COMPRESSOR		OFM	IFM	POWER SUPPLY				
		MIN	MAX	RLA	LRA	FLA	FLA	MCA	FUSE OR HACR BKR			
48ES-018	208/230-1-60	187	253	9.0	48.0	0.9	1.8	13.9	20			
48ES-024				13.5	58.3	0.9	2.0	19.7	30			
48ES-030				12.8	64.0	0.9	2.0	18.9	30			
48ES-036				14.1	77.0	0.9	4.1	22.6	35			
48ES-042				17.9	112.0	0.9	4.1	27.4	40			
48ES-048				21.8	117.0	1.5	4.1	32.8	50			
48ES-060				26.4	134.0	1.5	6.2	40.7	60			
48ESN018				9.0	48.0	0.9	1.8	13.9	20			
48ESN024				13.5	58.3	0.9	2.0	19.7	30			
48ESN030				12.8	64.0	0.9	2.0	18.9	30			
48ESN036				14.1	77.0	0.9	4.1	22.6	35			
48ESN042				17.9	112.0	0.9	4.1	27.4	40			
48ESN048				21.8	117.0	1.5	4.1	32.8	50			
48ESN060				26.4	134.0	1.5	6.2	40.7	60			
48ES-030				208/230-3-60	187	253	10.1	58.0	0.9	2.0	15.5	25
48ES-036							9.2	71.0	0.9	4.1	16.5	25
48ES-042							13.5	88.0	0.9	4.1	21.9	30
48ES-048							13.8	83.1	1.5	4.1	22.9	35
48ES-060							17.7	110.0	1.5	6.2	29.8	40
48ESN030							10.1	58.0	0.9	2.0	15.5	25
48ESN036							9.2	71.0	0.9	4.1	16.5	25
48ESN042							13.5	88.0	0.9	4.1	21.9	30
48ESN048							13.8	83.1	1.5	4.1	22.9	35
48ESN060							17.7	110.0	1.5	6.2	29.8	40
48ES-036	460-3-60	414	506				5.6	38.0	0.6	1.9	9.5	15
48ES-042							6.0	44.0	0.6	1.9	10.0	15
48ES-048				6.2	41.0	0.8	1.9	10.5	15			
48ES-060				7.8	52.0	0.9	2.7	13.3	20			
48ESN036				5.6	38.0	0.6	1.9	9.5	15			
48ESN042				6.0	44.0	0.6	1.9	10.0	15			
48ESN048				6.2	41.0	0.8	1.9	10.5	15			
48ESN060				7.8	52.0	0.9	2.7	13.3	20			

48ES

### LEGEND

- FLA -- Full Load Amps
- LRA -- Locked Rotor Amps
- MCA -- Minimum Circuit Amps
- MOCP -- Maximum Overcurrent Protection
- RLA -- Rated Load Amps



EXAMPLE: Supply voltage is 230-3-60.

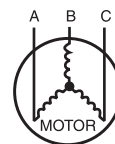

- AB = 228 v
- BC = 231 v
- AC = 227 v

$$\begin{aligned} \text{Average Voltage} &= \frac{228 + 231 + 227}{3} \\ &= \frac{686}{3} \\ &= 229 \end{aligned}$$

Determine maximum deviation from average voltage.

- (AB) 229 - 228 = 1 v
- (BC) 231 - 229 = 2 v
- (AC) 229 - 227 = 2 v

Maximum deviation is 2 v.

Determine percent of voltage imbalance

$$\begin{aligned} \% \text{ Voltage Imbalance} &= 100 \times \frac{2}{229} \\ &= 0.8\% \end{aligned}$$

This amount of phase imbalance is satisfactory as it is below the maximum allowable 2%.

**IMPORTANT:** If the supply voltage phase imbalance is more than 2%, contact your local electric utility company immediately.

A06564







# CONTROLS

## Operating sequence

**Heating** — When the thermostat calls for heating, terminal “W” is energized, starting the induced draft motor. When the hall-effect sensor on the induced-draft motor senses that it has reached the required speed, the burner ignition sequence begins. The indoor (evaporator) fan motor (IFM) is energized 45 seconds after flame is established. When the thermostat is satisfied and “W” is de-energized, the IFM stops after a 45-second time-off delay. Please note that the ignition control board (IGC) has the capability to automatically reduce the indoor fan motor on and off delays in the event of high duct static and/or partially-clogged filter. An adjustment of fan delays by the ignition control board is indicated by a flash code “1” on the LED on the IGC.

**Cooling** — When the system thermostat calls for cooling, 24 V is supplied to the “Y” and “G” terminals of the thermostat. This completes the circuit to the contactor coil (C) and indoor (evaporator) fan relay (IFR). The normally open contacts of energized C close and complete the circuit through compressor motor (COMP) to outdoor (condenser) fan motor (OFM). Both motors start instantly. The set of normally open contacts of energized IFR close and complete the circuit through IFM. The IFM starts instantly.

On the loss of the thermostat call for cooling, 24 V is removed from both the “Y” and “G” terminals (provided the fan switch is in the “AUTO” position) de-energizing the compressor contactor and opening the contacts supplying power to compressor/OFM. After a 30-second delay, the IFM shuts off. If the thermostat fan selector switch is in the “ON” position, the IFM will run continuously.

**NOTE:** On units with a Time Guard® II device: Once the compressor has started and then stopped, it cannot be restarted again until 5 minutes have elapsed.

# GUIDE SPECIFICATIONS

## Packaged Gas Heating/Electric Cooling Units Constant Volume Application

### HVAC Guide Specifications

Size Range: **1-1/2 to 5 Tons, Nominal Cooling  
40,000 to 130,000 Btuh,  
Nominal Heating Input**

Carrier Model Number: 48ES

#### Part 1 — General

##### SYSTEM DESCRIPTION

Outdoor rooftop mounted, gas heating/electric cooling unit utilizing a hermetic scroll compressor for cooling duty. Unit shall discharge supply air vertically or horizontally as shown on contract drawings. Condenser fan/coil section shall have a draw-thru design with vertical discharge for minimum sound levels.

##### QUALITY ASSURANCE

- A. Unit shall be rated in accordance with ARI Standards 210/240-03 and 270-95.
- B. Unit shall be designed in accordance with UL Standard 1995.
- C. Unit shall be manufactured in a facility registered to ISO 9001 manufacturing quality standard.
- D. Unit shall be UL listed and c-UL certified as a total package for safety requirements.
- E. Roof curb shall be designed to conform to NRCA Standards.
- F. Insulation and adhesives shall meet NFPA 90A requirements for flame spread and smoke generation.
- G. Cabinet insulation shall meet ASHRAE Standard 62P.

##### DELIVERY, STORAGE AND HANDLING

Unit shall be stored and handled per manufacturer's recommendations.

#### Part 2 — Products

##### EQUIPMENT

###### A. General:

Factory-assembled, single-piece, heating and cooling unit. Contained within the enclosure shall be all factory wiring, piping, controls, refrigerant charge with R-410A refrigerant, and special features required prior to field start-up.

###### B. Unit Cabinet:

1. Unit cabinet shall be constructed of phosphated, zinc-coated, pre-painted steel capable of with-standing 500 hours in salt spray.
2. Normal service shall be through a single removable cabinet panel.
3. The unit shall be constructed on a rust proof unit base that has an externally trapped, integrated sloped drain.
4. Evaporator fan compartment top surface shall be insulated with a minimum 1/2-in. thick, flexible fiberglass insulation, coated on the air side and retained by adhesive and mechanical means. The evaporator wall sections will be insulated with a minimum semi-rigid foil-faced board capable of being wiped clean. Aluminum foil-faced fiberglass insulation shall be used in the entire indoor air cavity section.
5. Unit shall have a field-supplied condensate trap.

###### C. Fans:

1. The evaporator fan shall be 3-speed (2-speed 018 size), direct-drive, as shown on equipment drawings.
2. Fan wheel shall be made from steel, be double-inlet type with forward curved blades with corrosion resistant finish. Fan wheel shall be dynamically balanced.

3. Condenser fan shall be direct drive propeller type with aluminum blades riveted to corrosion resistant steel spiders, be dynamically balanced, and discharge air vertically.

###### D. Compressor:

1. Fully hermetic compressors with factory-installed vibration isolation.
2. Scroll compressors shall be standard on all units.

###### E. Coils:

Evaporator and condenser coils shall have aluminum plate fins mechanically bonded to seamless copper tubes with all joints brazed (Copper/copper and vinyl-coated construction available as option). Tube sheet openings shall be belled to prevent tube wear.

###### F. Heating Section:

1. Induced-draft combustion type with energy saving direct spark ignition system and redundant main gas valve.
2. Induced-draft motors shall be provided with solid-state hall-effect sensor to ensure adequate airflow for combustion.
3. The heat exchangers shall be constructed of aluminized steel for corrosion resistance.
4. Burners shall be of the in-shot type constructed of aluminum coated steel.
5. All gas piping and electric power shall enter the unit cabinet at a single location.

###### G. Refrigerant Components:

Refrigerant expansion device shall be of the TXV (thermostatic expansion valve) type.

###### H. Filters:

Filter section shall consist of field-installed, throwaway, 1-in. thick fiberglass filters of commercially available sizes.

###### I. Controls and Safeties:

1. Unit controls shall be complete with a self-contained low voltage control circuit.
2. Compressors shall incorporate a solid-state compressor protector that provides reset capability.

###### J. Operating Characteristics:

1. Unit shall be capable of starting and running at 125°F (51°C) ambient outdoor temperature per maximum load criteria of ARI Standard 210.
2. Compressor with standard controls shall be capable of operation down to 40°F (4°C) ambient outdoor temperature.
3. Units shall be provided with fan time delay to prevent cold air delivery before the heat exchanger warms up.
4. Unit shall be provided with 30-second fan time delay after the thermostat is satisfied.

###### K. Electrical Requirements:

All unit power wiring shall enter the unit cabinet at a single location.

###### L. Motors:

1. Compressor motors shall be of the refrigerant-cooled type with line-break thermal and current overload protection.
2. All fan motors shall have permanently lubricated bearings, and inherent, automatic reset, thermal overload protection.
3. Condenser fan motor shall be totally enclosed.

## GUIDE SPECIFICATIONS (CONT)

### M. Special Features Available:

1. Louvered Grille:  
Wire grille shall be standard on all units. Louvered grille shall be available as a factory-installed option to provide hail guard and vandalism protection.
2. Coil Options:  
Shall include factory-installed optional copper/copper and vinyl-coated refrigerant coils.
3. Economizer:
  - a. Economizer controls capable of providing free cooling using outside air.
  - b. Equipped with low leakage dampers not to exceed 3% leakage, at 1.0 in. wc pressure differential.
  - c. Spring return motor shuts off outdoor damper on power failure.
4. Flat Roof Curb:  
Curbs shall have seal strip and a wood nailer for flashing and shall be installed per manufacturer's instructions.
5. Manual Outdoor Air Damper:  
Package shall consist of damper, birdscreen, and rainhood which can be preset to admit outdoor air for year-round ventilation.
6. Thermostat:  
To provide for one-stage heating and cooling in addition manual or automatic changeover and indoor fan control.
7. Natural-to-Propane Conversion Kit:  
Shall be complete with all required hardware to convert to propane gas operation at 3.5 in. wc manifold pressure.
8. Propane-to-Natural Conversion Kit  
Shall be complete with all hardware to convert to natural gas at standard altitude (0 to 2000 ft above sea level).
9. Low Ambient Package:  
Shall consist of a solid-state control and condenser coil temperature sensor for controlling condenser-fan motor operation, which shall allow unit to operate down to 0°F outdoor ambient temperature when properly installed.
10. Filter Rack Kit:  
Shall provide filter mounting for downflow applications.
11. Square-To-Round Duct Transitions (018-048):  
Shall have the ability to convert the supply and return openings from rectangular to round.
12. Compressor Protection:  
Solid-state control shall protect compressor by preventing "short cycling."
13. Crankcase Heater:  
Shall provide anti-floodback protection for low-load cooling applications.
14. High Altitude Propane Conversion Kit:  
Shall consist of natural gas orifices to compensate for gas heat operation at 2001 to 6000 ft above sea level.
15. Low NOx:  
Shall provide NOx reduction to values below 40 nanograms/joule to meet California emission requirements as shipped from factory.
16. Compressor Hard Start Kit (single phase units only):  
Shall provide additional starting torque for single-phase compressors.

48ES