

**48PD and 50PD-05, 06  
Displacement Ventilation or Single-Zone Variable Airflow Rooftop Units  
Single Package, Electric Cooling, Gas or Optional Electric Heating  
with PURON® (R-410A) Refrigerant and COMFORTLink™ Controls**

# Advanced Product Data

This manual provides product information related with the usage and application of the Centurion 48/50PD product series. It is to be used in conjunction with the Packaged RTU Builder software for performance data and unit selection until replaced by the product data manual.

## TABLE OF CONTENTS

FEATURES AND BENEFITS .....	1
UNIT OPERATION SUMMARY .....	2
MODEL NUMBER NOMENCLATURE .....	3
ARI CAPACITY RATINGS .....	4
HEATING TABLES .....	5
PHYSICAL DATA .....	7
FACTORY OPTIONS AND ACCESSORIES .....	10
OPTIONS & ACCESSORY WEIGHTS .....	11
BASE UNIT DIMENSIONS .....	12
CURB DIMENSIONS .....	14
SELECTION PROCEDURE .....	15
COOLING CAPACITY DATA .....	16
INDOOR FAN DATA .....	18
ELECTRICAL DATA .....	19
TYPICAL WIRING SCHEMATICS .....	24
SEQUENCE OF OPERATION .....	27
APPLICATION DATA .....	30
GUIDE SPECIFICATIONS .....	32

## FEATURES AND BENEFITS

The Centurion 48/50PD rooftop units use Puron® (R-410A) refrigerant and *ComfortLink*™ DDC controls. These units are intended to be used in a either a displacement ventilation or a single-zone variable air volume application. In addition the standard features and benefits of a Centurion rooftop unit, the PD units include a factory installed variable capacity compressor and variable frequency drive indoor fan motor.

### PERFORMANCE FEATURES INCLUDE:

- Puron (R-410A) HFC refrigerant
- SEER up to 15.2, EER up to 12.8
- ARI certified outdoor sound levels as low as 72 db
- Fully hermetic, digital scroll compressors with capacity modulation provide any capacity between 15 and 100%.
- ComfortLINK Direct Digital Controls (DDC)
- Phase loss and compressor reverse rotation protection
- TXV refrigerant metering system on each circuit
- High Pressure, Low Pressure/Loss of charge, and Freeze protection.
- Solid core liquid line filter drier on each circuit.
- Ambient cooling operation from 0°F up to 125°F
- Foil faced insulation throughout entire unit
- Pre-painted exterior panels and primer-coated interior panels tested to 500 hours ASTM B117 (scribed specimen)salt spray protection

- Rust-proof, internally sloped condensate pan conforms to ASHRAE 62 standards
- Evaporator fan motor system with high performance belt drives and variable speed motors from 20% to 100%
- Internally protected, shaft down totally enclosed condenser motors
- 2 inch filter standard, field convertible to 4 inch capability
- 24 volt control system with resettable circuit breakers
- Induced draft combustion (gas units)
- Redundant gas valves with up to two stages of heating (gas units)
- Models 48/50PD 05-06 units are ENERGY STAR qualified

### MAINTENANCE FEATURES:

- Single slab, single pass evaporator and condenser coils with dual side access panels
- Hinged access doors with, quick turn latches and door retainers
- Slide out indoor fan assembly for added service convenience
- Dedicated, fully insulated compressor compartment
- Rust-proof, slide out evaporator condensate pan
- Permanently lubricated evaporator, condenser and inducer motors

### INSTALLATION FEATURES:

- Thru the bottom and side weather tight electrical access plate
- Thru the bottom and side gas connection capabilities
- Single point electrical and gas connections
- Return and supply duct fits between 24" on center joist
- Field convertible from vertical to horizontal airflow
- Single piece outdoor air hoods
- Full perimeter base rail with built-in rigging adapters and fork truck slots

### FACTORY INSTALLED OPTIONS INCLUDE:

- Supply and/or return air smoke detectors
- Powered or non-powered 115 volt convenience outlet
- Non-fused disconnect switch or circuit breaker
- Dry bulb or enthalpy economizer with/without return air CO<sub>2</sub> sensor
- Two-position motorized outdoor damper
- Barometric relief damper
- Power Exhaust
- Condenser coil guard
- Copper/Copper coils
- Pre-coated condenser coil
- E-coated coils
- Fan status and filter status switches
- High static indoor fan and drive systems
- Factory or field installed electric heaters (electric heat units)
- Stainless steel gas heat exchanger (gas units)
- Low NOx models that meet California Air Quality Management requirements (gas units)

## UNIT SUMMARY

There are two key elements that separate a Centurion PD unit from other Centurion units; the use of a variable speed fan and a modulating compressor. The modulating compressor allows the fan speed to slow down without the refrigerant coil freezing during low load, and also allows for variable supply air temperatures. In general, a space temperature input is used to control the airflow and a supply air temperature input is used to control the compressor load. All other components of this machine are similar to concepts used on other Carrier package units. An economizer is used to take advantage of any free cooling opportunities in addition to providing the required outside air. Additionally, all units will come standard with factory installed *ComfortLink* controls which makes demand controlled ventilation easy to install and implement. If this unit is to be integrated with an open protocol type building automation system a translator card or LEI card can be installed and the unit can be viewed on an up front system. If humidity is a concern, a humidistat can be installed in the zone, and the indoor fan will slow down to ensure proper moisture removal from the supply air.

Although this unit was designed for the requirements of a displacement ventilation system, it can also be used in a single-zone variable air volume application. However, the use of a supply air pressure input to control the Centurion PD unit is not supported nor recommended; the unit is not designed to provide a constant supply air pressure.

Centurion PD units are ideal on buildings that are looking for either maintenance friendly units or trying to achieve LEED certification. The units have a high SEER value, but more importantly, the modulating compressor and fan system allow a significant reduction in overall energy consumption beyond what is quantified by the SEER value. This can contribute significantly to the LEED intent of achieving overall lower building energy consumption. Initial studies have shown that a Centurion PD unit can use up to 35% fewer kilowatts than a typical constant volume unit over the cooling season.

## DISPLACEMENT VENTILATION SUMMARY

Displacement Ventilation (DV) systems are very closely related to the design of underfloor air systems. Although the air delivery method is slightly different, the design philosophy is the same. Displacement ventilation discharges air horizontally near the floor at very low velocities and near laminar flow conditions. The goal is to use only the buoyancy effects to create air motion within the space and maintain the stratification layer above the controlled zone that is not mixed. The air is introduced at the floor level at approximately 65°F and the air moves upward through the space taking both heat and any contaminants that might be in the air up out of the occupied space to the ceiling. Unlike displacement

ventilation a mixing ventilation system requires more cooling capacity since air must be cooled significantly before it is introduced into the classroom or office. Displacement ventilation does not require the same cooling capacity; it uses warmer air delivered at 63° to 68° to achieve that same space set point.

The DV system use is a feasible alternative to the current practice of mixing air distribution systems. It is energy efficient, quiet and distributes air more efficiently than other ventilation systems. It improves the indoor air quality (IAQ) by providing supply air directly to building occupants and saves energy by conditioning only the lower occupied portion of a space. Displacement Ventilation is a means of providing cool supply air directly to the occupants in a room such as a classroom or auditorium. In the case of a school classroom, cooling is localized where the occupants are located. The air is heated or cooled so that it enters the room at ~65°F, considerably warmer than with a conventional air conditioning system. The fresh air, supplied near the floor at a very low velocity, falls towards the floor due to gravity and spreads across the room until it comes in contact with heat sources, such as people and computers. As this cool air picks up heat from the school's occupants and equipment it slowly rises. This creates a vertical airflow pattern near each occupant: often called a thermal plume. Contaminants such as germs are caught in the thermal plume and removed from each occupant toward the ceiling, where they exit the classroom or auditorium.

Refer to Carrier Application Data for the 45XC (Catalog No. 04-51450001-01) for the design of Underfloor Air Distribution Systems for additional details on Displacement Ventilation Application and Design.

## SINGLE-ZONE VAV SUMMARY

A Single-Zone Variable Air Volume (VAV) concept utilizes a variable capacity compressor system and a variable speed fan system to modulate the cooling, dehumidification and airflow as required meeting the space needs. Unlike traditional VAV applications, there are no mixing boxes or bypass ducts because the application is a single zone. The space temperature can be set and maintained very accurately using a space temperature sensor (not a thermostat). Space humidity control is a built in feature with the addition of a humidistat. Supply air temperatures and airflows will vary based on the demand from the space.

Design parameters of the system should be based around the maximum cooling and heating design parameters, just like on a constant volume system. The unit will modulate the cooling, dehumidification and airflow to meet not only the design cooling demand, but the part-load cooling and dehumidification demand as well.

## 48PD and 50PD Model Number Nomenclature

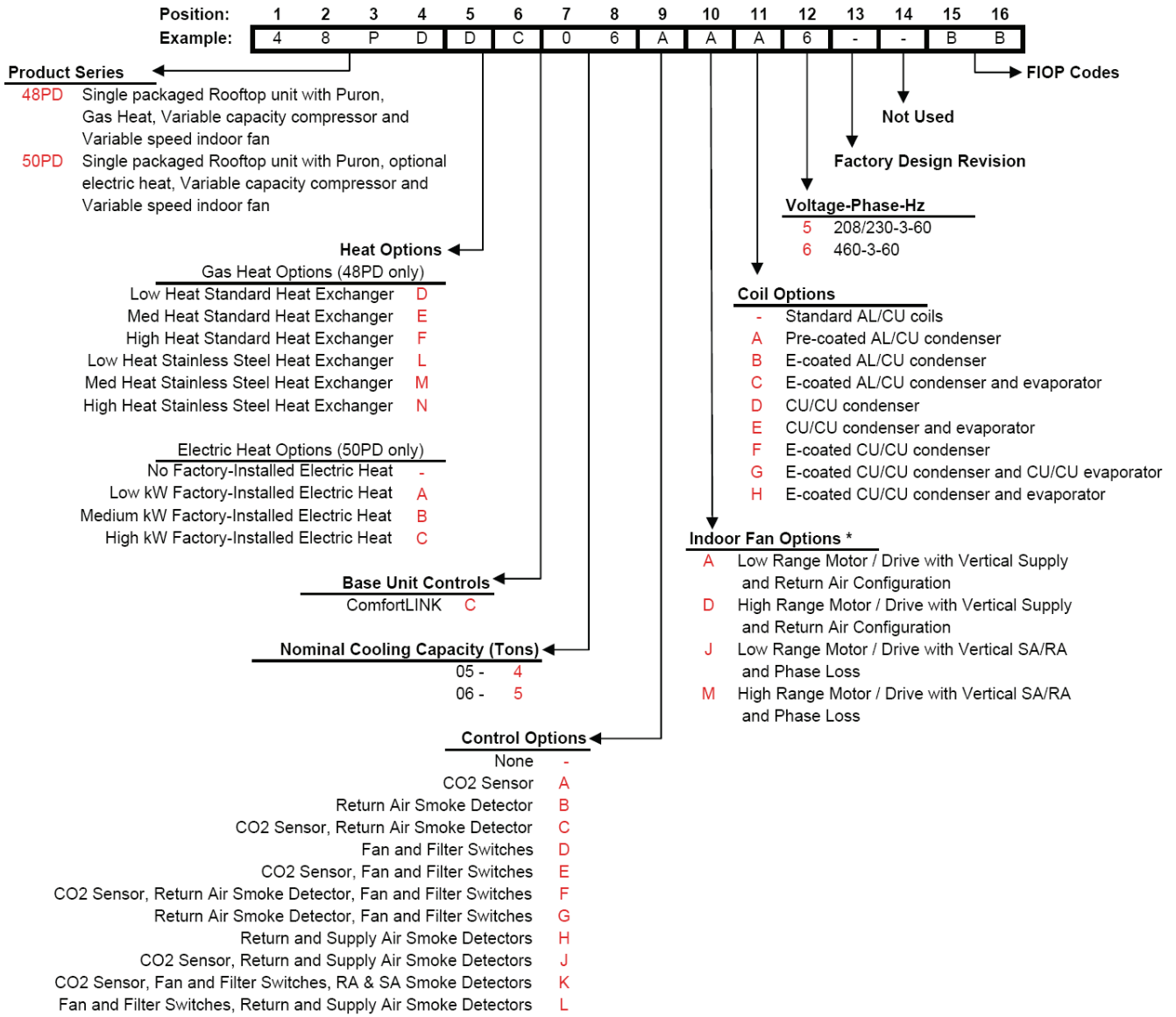

\* Units are field convertible to horizontal supply and/or return air configuration. Horizontal conversion may require different accessory devices.

## ARI CAPACITY RATINGS

Model	Nominal Tons *	Cooling Capacity (MBTUH)	SEER	EER	Rated CFM	SOUND RATING (dB)
48PD 05	4	47,500	15.2	12.8	1,600	72
48PD 06	5	58,500	14.8	12.2	1,750	78

Model	Nominal Tons *	Cooling Capacity (MBTUH)	SEER	EER	CFM	SOUND RATING (dB)
50PD 05	4	47,500	15.2	12.8	1,600	72
50PD 06	5	58,500	14.8	12.2	1,750	78

\* Nominal cooling tons shown is the maximum design capacity value.

### LEGEND

ARI - Air Conditioning and Refrigeration Institute.

dB - decibel

EER - Energy Efficiency Ratio

SEER --- Seasonal Energy Efficiency Ratio

### NOTES:

1. Tested in accordance with ARI Standards 210---94
2. Ratings are net values, reflecting the effects of circulating fan heat.
3. Ratings are based on:  
**Cooling Standard:** 80 F db, 67 F wb indoor entering---air temperature and 95 F db air entering outdoor unit.
4. All 48/50PD units are in compliance with ENERGY STAR® and ASHRAE 90.1-2004 Energy Standard for minimum SEER and EER requirements.
5. Units are rated in accordance with ARI sound standards 270 or 370.



### 48PD & 50PD - OUTDOOR SOUND POWER (TOTAL UNIT)

UNIT SIZE	ARI RATING (dB)	A-WEIGHTED (db)	OCTAVEBANDS							
			63	125	250	500	1000	2000	4000	8000
05	72	82.6	80.1	81.1	78.8	77.2	77.4	76.4	72.4	70
06	78	83.8	82.4	83.4	81.6	79.1	78.8	76.9	72.9	70.2

### LEGEND

ARI — Air Conditioning and Refrigeration Institute

Db – decibels

**NOTE:** Indoor sound power is available via Carrier's Electronic Catalog Program for specific operating parameters.

## 48PD 05-06 GAS HEAT CAPACITIES AND EFFICIENCIES

### VERTICAL & HORIZONTAL SUPPLY UNITS (NATURAL GAS) - SINGLE PHASE

48PD		Heating Input (Btuh)	Output Capacity (Btuh)	Temperature Rise Min - Max (F)	Minimum Heating CFM **	Thermal Efficiency (%)	AFUE (%)
Standard	Stainless Steel						
—	L05*	51,000	39,400	25 ---70	500		
D05	—	56,000	43,300	25 ---70	600	81	80
E05	M05*	75,000	58,800	20 ---60	940		
F05	N05*	113,000	89,900	30 ---75	1,130		
D06	L06*	75,000	58,800	20 ---60	940	81	80
E06	M06*	113,000	89,900	30 ---75	1,130		
F06	N06*	151,000	121,500	45 ---75	1,510		

### VERTICAL & HORIZONTAL SUPPLY UNITS (NATURAL GAS) - THREE PHASE

48PD		Heating Input Stage 2 (Btuh)	Heating Input Stage 1 (Btuh)	Output Capacity Stage 2 (Btuh)	Temperature Rise Min - Max (F)	Minimum Heating CFM **	Thermal Efficiency (%)
Standard	Stainless Steel						
—	L05*	51,000	35,700	41,300	25 ---70	500	81
D05	—	56,000	39,200	45,400	25 ---70	600	
E05	M05	75,000	52,500	60,800	20 ---60	940	
F05	N05*	113,000	79,100	91,500	30 ---75	1,130	
D06	L06*	75,000	52,500	60,800	20 ---60	940	81
E06	M06*	113,000	79,100	91,500	30 ---75	1,130	
F06	N06*	151,000	105,700	122,300	45 ---75	1,510	

### VERTICAL & HORIZONTAL SUPPLY UNITS (PROPANE) - SINGLE PHASE

48PD		Heating Input (Btuh)	Output Capacity (Btuh)	Temperature Rise Min - Max (F)	Minimum Heating CFM **	Thermal Efficiency (%)	AFUE (%)
Standard	Stainless Steel						
D05	L05	55,000	42,500	25 ---70	600	81	80
E05	M05	74,000	58,000	20 ---60	940		
F05	N05	111,000	88,400	30 ---75	1,130		
D06	L06	74,000	58,000	20 ---60	940	81	80
E06	M06	111,000	88,400	30 ---75	1,130		
F06	N06	148,000	119,100	45 ---75	1,510		

### VERTICAL & HORIZONTAL SUPPLY UNITS (PROPANE) - THREE PHASE

48PD		Heating Input Stage 2 (Btuh)	Heating Input Stage 1 (Btuh)	Output Capacity Stage 2 (Btuh)	Temperature Rise Min - Max (F)	Minimum Heating CFM **	Thermal Efficiency (%)
Standard	Stainless Steel						
D05	L05	55,000	38,500	44,600	25 ---70	600	81
E05	M05	74,000	51,800	60,000	20 ---60	940	
F05	N05	111,000	77,700	90,000	30 ---75	1,130	
D06	L06	74,000	51,800	60,000	20 ---60	940	81
E06	M06	111,000	77,700	90,000	30 ---75	1,130	
F06	N06	148,000	103,600	120,000	45 ---75	1,510	

#### 48PD - NG Altitude Compensation\*

ELEVATION (ft)	NATURAL GAS ORIFICE †	LP GAS ORIFICE †
0-1,999	45	52
2,000	47	52
3,000	47	53
4,000	47	53
5,000	48	53
6,000	48	53
7,000	48	53
8,000	49	54
9,000	49	54
10,000	50	54
11,000	51	54
12,000	51	55
13,000	52	55
14,000	52	56

#### 48PD - Orifice Quantity

UNIT	05	06
Low Heat (D/L)	3	4
Medium Heat (E/M)	4	6
High Heat (F/N)	6	8

\*As the height above sea level increases, there is less oxygen per cubic foot of air. Therefore, heat input rate should be reduced at higher altitudes. Includes a 4% input reduction per each 1000 ft.

† Orifices available through your Carrier dealer.

## 50PD 05-06 ELECTRIC HEAT CAPACITIES

50PD UNIT SIZE	NOMINAL POWER SUPPLY	FIELD INSTALLED ELECTRIC HEAT			Single point kit
	Volt-Ph-Hz	Heater Number	FLA	Nom. kW	
05	208-3-60	-	0.0	-	
		CRHEATER208A00	10.0	3.8	-
		CRHEATER209A00	15.0	5.6	-
		CRHEATER210A00	20.0	7.5	-
		CRHEATER211A00	30.0	11.3	-
		CRHEATER212A00	40.0	15.0	031
	230-3-60	-	0.0	-	
		CRHEATER208A00	11.5	5.0	-
		CRHEATER209A00	17.3	7.5	-
		CRHEATER210A00	23.1	10.0	-
		CRHEATER211A00	34.6	15.0	-
		CRHEATER212A00	46.2	20.0	031
	460-3-60	-	0.0	-	
		CRHEATER215A00	5.8	5.0	-
		CRHEATER216A00	8.7	7.5	-
		CRHEATER217A00	11.5	10.0	-
		CRHEATER218A00	17.3	15.0	-
		CRHEATER219A00	23.1	20.0	-
06	208-3-60	-	0.0	-	
		CRHEATER208A00	10.0	3.8	-
		CRHEATER209A00	15.0	5.6	-
		CRHEATER210A00	20.0	7.5	-
		CRHEATER211A00	30.0	11.3	-
		CRHEATER212A00	40.0	15.0	031
	230-3-60	-	0.0	-	
		CRHEATER208A00	11.5	5.0	-
		CRHEATER209A00	17.3	7.5	-
		CRHEATER210A00	23.1	10.0	-
		CRHEATER211A00	34.6	15.0	-
		CRHEATER212A00	46.2	20.0	031
	460-3-60	-	0.0	-	
		CRHEATER215A00	5.8	5.0	-
		CRHEATER216A00	8.7	7.5	-
		CRHEATER217A00	11.5	10.0	-
		CRHEATER218A00	17.3	15.0	-
		CRHEATER219A00	23.1	20.0	-
		CRHEATER220A00	28.9	25.0	-

## 48PD PHYSICAL DATA TABLE

	48PD--05	48PD--06
<b>NOMINAL CAPACITY (TONS)</b>	4	5
<b>OPERATING WEIGHT (lbs) *</b>		
BASE UNIT	901	921
Economizer Vertical / Horizontal	40 / 50	40 / 50
Roof Curb 14-in / 24-in	122 / 184	122 / 184
<b>REFRIGERANT SYSTEM</b>		
Refrigerant	Puron (410a)	
Metering Device	Balanced-Port TXV with Bypass	
# Circuits / # Compressors	1 / 1	1 / 1
Charge (lbs)	14.5	16.0
High Pressure Switch Cutout (psig)	660 +/- 10	660 +/- 10
High Pressure Switch Auto Reset (psig)	505 +/- 20	505 +/- 20
<b>COMPRESSOR</b>		
Oil Type	Copeland Digital Scroll Copeland 3MA	
Oil (oz)	42	42
<b>CONDENSER COIL</b>		
	Round Tube Plate Fin	
Circuit	Outer / Inner	Outer / Inner
Rows / FPI	2 / 17	2 / 17
Face Area (sq ft)	12.6	12.6
<b>CONDENSER FAN (type)</b>		
	Propeller	
Quantity / Diameter (in.)	1 / 24	1 / 24
Nominal CFM (Total, all fans)	3500	3500
Motor Nominal Hp / Watts	0.125 / 227	0.25 / 351
Nominal RPM	825	1100
<b>EVAPORATOR COIL</b>		
	Round Tube Plate Fin	
Standard coil Tube / Fins	Cu/Al	Cu/Al
Rows / FPI	2 / 15	3 / 15
Face Area (sq ft)	9.3	9.3
Condensate drain conn. Size (in.)	3/4 NPT	3/4 NPT
<b>EVAPORATOR FAN (see motor &amp; drive tables)</b>		
Fan Quantity / Type	1 / Belt	1 / Belt
Belt Size (in.)	12 x 9	12 x 9
Blower Pulley Type	Fixed	Fixed
Fan type	Centrifugal	Centrifugal
Fan Bearing Type	Ball - Concentric Lock	Ball - Concentric Lock
Maximum Fan RPM	2000	2000
Blower Shaft Diameter (in.)	0.75	0.75
Motor Max HP	2.4	2.4
Motor Frame Size	56HZ	56HZ
<b>FILTERS</b>		
Unit Filter Type	Fiberglass fill, non-pleated	Fiberglass fill, non-pleated
Unit Filter Qty / size (in)	4 / 16 x 20 x 2	4 / 16 x 20 x 2
Economizer OA inlet screen Qty / size (in)	1 / 25.8 x 16.4	1 / 25.8 x 16.4

\* Aluminum Evaporator Coil / Aluminum Condenser Coil with Low Heat

## 48PD PHYSICAL DATA TABLE – CONT'D

GAS HEAT SECTION			
		# of Gas Valves	1
		Gas Supply Line Pressure Range (in. wg.)	5.0 - 13.0
		Gas Supply Line Pressure Range (PSIG)	0.180 - 0.469
		Manifold Pressure (in. wg.)	0.180 - 0.469
		Natural Gas Vertical / Horizontal	3.50 / 3.50
		Liquid Propane Vertical / Horizontal	3.50 / 3.50
		Thermostat Heat Anticipator Setting (amps)	NA †
		Field Gas Connection Size (in.)	1/2
Natural Gas			
LOW HEAT		# of burners (total)	3
		Rollout switch opens / closes (deg F)	195 / 115
		Temperature Rise Min - Max (deg F)	25 - 70
		Burner Orifice Diameter (in. /drill size)**	0.0820/45
MEDIUM HEAT		# of burners (total)	4
		Rollout switch opens / closes (deg F)	195 / 115
		Temperature Rise Min - Max (deg F)	20 - 60
		Burner Orifice Diameter (in. /drill size)**	0.0820/45
HIGH HEAT		# of burners (total)	6
		Rollout switch opens / closes (deg F)	225 / 175
		Temperature Rise Min - Max (deg F)	30 - 75
		Burner Orifice Diameter (in. /drill size)**	0.0820/45
Liquid Propane			
LOW HEAT		# of burners (total)	3
		Rollout switch opens / closes (deg F)	195 / 115
		Temperature Rise Min - Max (deg F)	25 - 70
		Burner Orifice Diameter (in. /drill size)**	0.0650 / 52
MEDIUM HEAT		# of burners (total)	4
		Rollout switch opens / closes (deg F)	195 / 115
		Temperature Rise Min - Max (deg F)	20 - 60
		Burner Orifice Diameter (in. /drill size)**	0.0650 / 52
HIGH HEAT		# of burners (total)	6
		Rollout switch opens / closes (deg F)	225 / 175
		Temperature Rise Min - Max (deg F)	30 - 75
		Burner Orifice Diameter (in. /drill size)**	0.0650 / 52

\*\* For applications less than 2000ft elevation.

† PD unit does not support the use of Conventional Y1/W1 Thermostat

## 50PD PHYSICAL DATA TABLE

	50PD--05	50PD--06
<b>NOMINAL CAPACITY (TONS)</b>	4	5
<b>OPERATING WEIGHT (lbs)</b>		
Base Unit *	901	921
Economizer Vertical / Horizontal	40 / 50	40 / 50
Roof Curb 14-in / 24-in	122 / 184	122 / 184
<b>REFRIGERANT SYSTEM</b>		
Refrigerant	Puron (410a)	
Metering Device	Balanced-Port TXV with Bypass	
# Circuits / # Compressors	1 / 1	1 / 1
Charge (lbs)	14.5	16.0
High Pressure Switch Cutout (psig)	660 +/- 10	660 +/- 10
High Pressure Switch Auto Reset (psig)	505 +/- 20	505 +/- 20
<b>COMPRESSOR</b>		
Oil Type	Copeland Digital Scroll Copeland 3MA	
Oil (oz)	42	42
<b>CONDENSER COIL</b>		
	Round Tube Plate Fin	
Circuit	Outer / Inner	Outer / Inner
Rows / FPI	2 / 17	2 / 17
Face Area (sq ft)	12.6	12.6
<b>CONDENSER FAN (type)</b>		
	Propeller	
Quantity / Diameter (in.)	1 / 24	1 / 24
Nominal CFM (Total, all fans)	3500	3500
Motor Nominal Hp / Watts	0.125 / 227	0.25 / 351
Nominal RPM	825	1100
<b>EVAPORATOR COIL</b>		
	Round Tube Plate Fin	
Standard coil Tube / Fins	Cu/Al	Cu/Al
Rows / FPI	2 / 15	3 / 15
Face Area (sq ft)	9.3	9.3
Condensate drain conn. Size (in.)	3/4 NPT	3/4 NPT
<b>EVAPORATOR FAN (see motor &amp; drive tables)</b>		
Fan Quantity / Type	1 / Belt	1 / Belt
Belt Size (in.)	12 x 9	12 x 9
Blower Pulley Type	Fixed	Fixed
Fan type	Centrifugal	Centrifugal
Fan Bearing Type	Ball - Concentric Lock	Ball - Concentric Lock
Maximum Fan RPM	2000	2000
Blower Shaft Diameter (in.)	0.75	0.75
Motor Max HP	2.4	2.4
Motor Frame Size	56HZ	56HZ
<b>FILTERS</b>		
Unit Filter Type	Fiberglass fill, non-pleated	Fiberglass fill, non-pleated
Unit Filter Qty / size (in)	4 / 16 x 20 x 2	4 / 16 x 20 x 2
Economizer OA inlet screen Qty / size (in)	1 / 25.8 x 16.4	1 / 25.8 x 16.4

\* Aluminum Evaporator Coil / Aluminum Condenser Coil

† PD unit does not support the use of Conventional Y1/W1 Thermostat

**48PD 05-06FIOP and Accessory Table**

Category	ITEM	STANDARD FEATURE	OPTION*	ACCESSORY†
Cabinet	Hinged Access Panels	X	X	
	Thru-the-Bottom Connections Gas			X
	Thru-the-Bottom Connections Electrical	X		
Coil Options	Copper Fins - condenser coil		X	
	Copper Fins - evaporator and condenser coil		X	
	E-Coat outdoor coil (Al / Cu) and indoor coil (Al / Cu)		X	
	E-Coat outdoor coil (Al / Cu)		X	
	E-Coat outdoor coil (Cu / Cu)		X	
	Pre-Coated Aluminum condenser fins		X	
Condenser Protection	Condenser Coil Grille		X	X
	High Pressure / Loss of Charge Switch	X		
	Low Pressure / Loss of Charge Switch	X		
	Evaporator Freeze protection switch	X		
Dehumidification & IAQ	Slide out, rust proof, sloped condensate pan	X		
	Foil Faced, cleanable insulation	X		
	Demand Control Ventilation CO2 Sensors			X
	Ultra-Violet Lights			X
	4-inch filter capability	X		
	MERV-8 Filters		X	
Economizers & Outdoor Air	EconoMi\$er - OA Temperature (includes barometric relief)		X	X
	EconoMi\$er - Single Enthalpy (includes barometric relief)		X	X
	100% Two-Position Damper (motorized)			X
	25% Two-Position Damper (motorized)			X
	Manual Outdoor-Air Damper			X
	Power Exhaust (prop fan)			X
Economizer Sensors	Return Air Temperature Sensor			X
	Return Air Enthalpy Sensor			X
	Outdoor Air Differential Temperature Sensor			X
	Outdoor Air Differential Enthalpy Sensor			X
	Return Air CO2 Sensor (duct mounted)			X
	Space CO2 Sensor (wall mounted)			X
Electrical & Controls	ComfortLink Communicating Controller	X		X
	HACR Breaker		X	
	Unit-Mounted Non-Fused Disconnect		X	
	Powered Convenience Outlet (Load or Line Side powered)		X	
	Non-Powered Convenience Outlet		X	
	Fan/Filter Status switches			X
48PD Gas Heat Exchanger	Stainless Steel Heat exchanger		X	
	Flue Discharge Deflector			X
	Low NOx heat exchanger		X	
	LP (Liquid Propane) Conversion Kit			X
50PD Electric Heat	Electric Heat		X	X
Indoor Motor & Drive	Standard Static Indoor Fan Drive		X	
	High-Static Indoor Fan Drive		X	
Low Ambient Control	Included with ComfortLink™ DDC Communicating Controller	X		
Roof Curbs	Roof Curbs 14" (Vertical or Horizontal Supply/Return)			X
	Roof Curbs 24" (Vertical or Horizontal Supply/Return)			X
	Burglar Bars			X
Thermostats & Sensors	Thermostats are not applicable to this product.	N/A	N/A	N/A
	Communicating Space Temperature Sensors with/without over-ride			X
	Relative Humidity Sensor (Space, Duct or Outdoor)			X

\* Factory Installed

† Field Installed

## Accessory Weight Adders

48PD Accessory Weights	05		06	
	lbs	kg	lbs	kg
2-position damper	30	14	30	14
4-in Filter Capability	No Additional Weight			
Barometric damper	No Additional Weight			
CO2 Sensor	5	2	5	2
Cu Condenser and Evaporator Coils	175	79	175	79
Cu Condenser Coils	100	45	100	45
Differential Enthalpy Sensor	3	1	3	1
Economizer Horizontal	50	23	50	23
Economizer Vertical	55	25	55	25
Enthalpy Sensor	2	1	2	1
Fan Status	2	1	2	1
Gas Heat - Low	No Additional Weight			
Gas Heat - High	30	14	30	14
Gas Heat - Medium	15	7	15	7
HACR Breaker	20	9	20	9
Hail Guard	50	23	50	23
Manual Damper	30	14	30	14
Non-Fused Disconnect	15	7	15	7
Non-Powered Conv Outlet	20	9	20	9
Plugged Filter Indicator	2	1	2	1
Power Exhaust	30	14	30	14
Powered Conv Outlet	35	16	35	16
Return Smoke Detector	5	2	5	2
Roof Curb 14-in	145	66	145	66
Roof Curb 24-in	155	70	155	70
Supply Smoke Detector	5	2	5	2

NOTE: All weights do NOT include packaging.

50PD Accessory Weights	05		06	
	lbs	kg	lbs	kg
2-position damper	30	14	30	14
4-in Filter Capability	No Additional Weight			
Barometric damper	No Additional Weight			
CO2 Sensor	5	2	5	2
Cu Condenser and Evaporator Coils	175	79	175	79
Cu Condenser Coils	100	45	100	45
Differential Enthalpy Sensor	3	1	3	1
Economizer Horizontal	50	23	50	23
Economizer Vertical	55	25	55	25
Electric Heat	30	14	30	14
Enthalpy Sensor	2	1	2	1
Fan Status	2	1	2	1
HACR Breaker	20	9	20	9
Hail Guard	50	23	50	23
Manual Damper	30	14	30	14
Non-Fused Disconnect	15	7	15	7
Non-Powered Conv Outlet	20	9	20	9
Plugged Filter Indicator	2	1	2	1
Power Exhaust	30	14	30	14
Powered Conv Outlet	35	16	35	16
Return Smoke Detector	5	2	5	2
Roof Curb 14-in	145	66	145	66
Roof Curb 24-in	155	70	155	70
Supply Smoke Detector	5	2	5	2

NOTE: All weights do NOT include packaging.

UNIT	STD. UNIT WEIGHT (LBS.)	UNIT WEIGHT (KG.)	CORNER WEIGHT (LBS.)	CORNER WEIGHT (KG.)	CORNER WEIGHT (LBS.)	CORNER WEIGHT (KG.)	CORNER WEIGHT (LBS.)	CORNER WEIGHT (KG.)
48PG03	774	351	170	77	142	65	210	95
48PG04	786	357	173	78	145	66	214	97
48PG05	901	409	198	90	166	75	245	111
48PG06	921	418	202	92	169	77	250	113
48PG07	961	436	211	96	177	80	261	118
48PD05	901	409	198	90	166	75	245	111
48PD06	921	418	202	92	169	77	250	113

DO NOT DRILL IN AREA BELOW BEAD

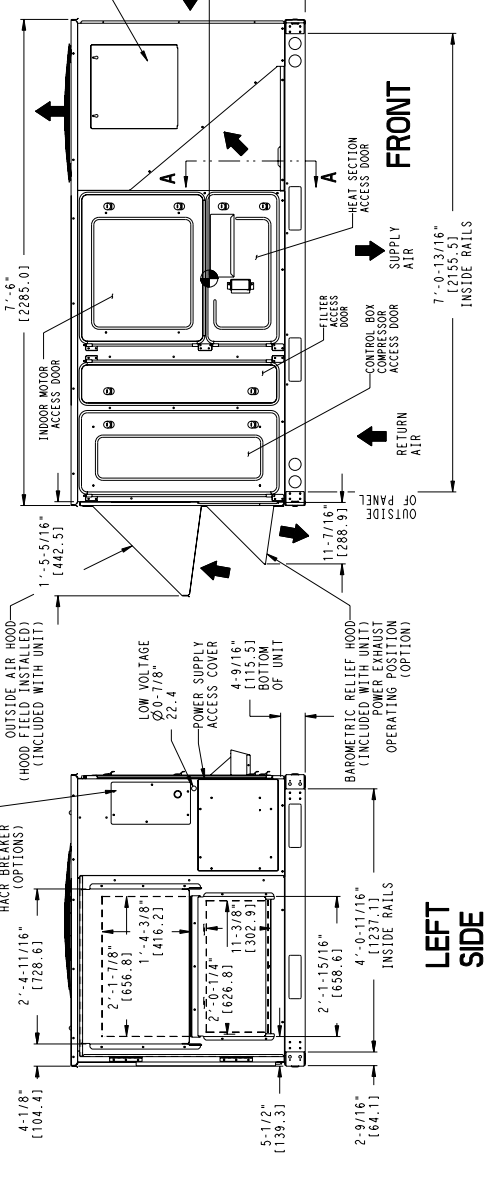
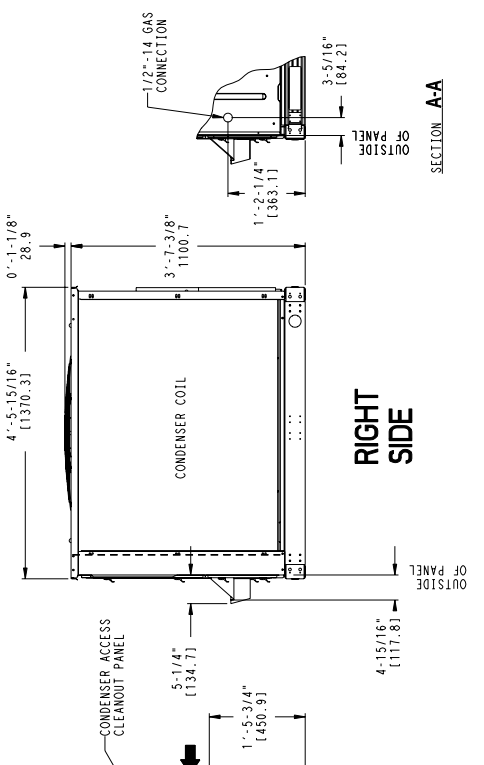
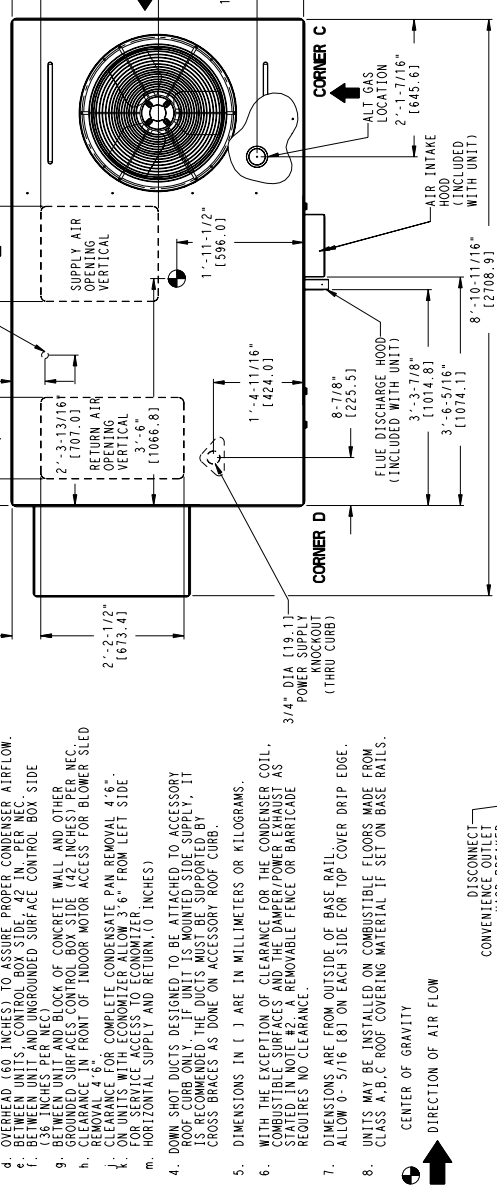
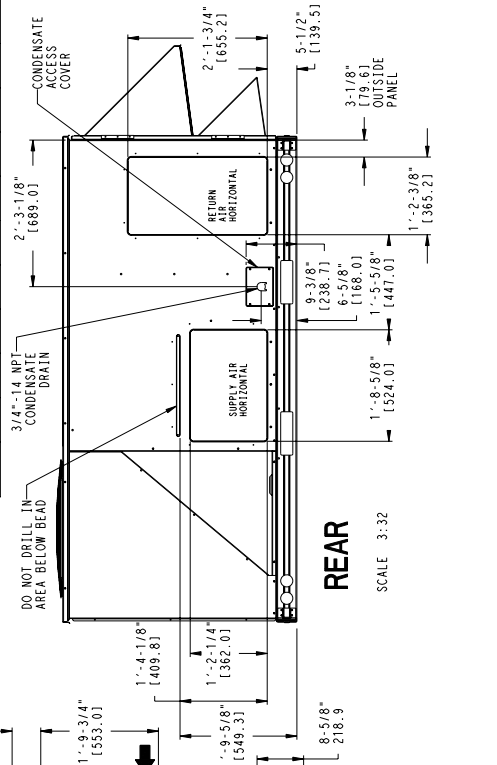
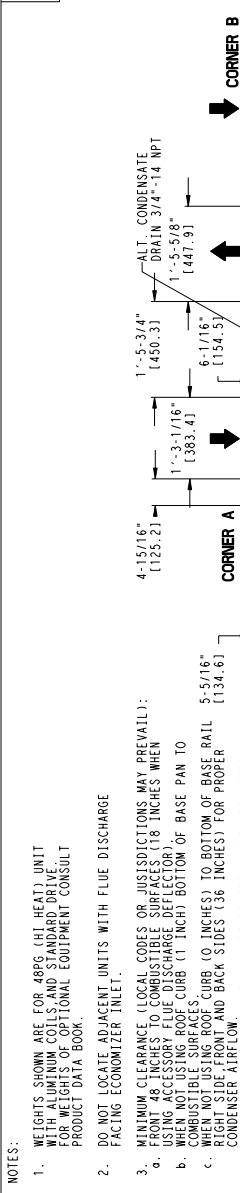

NOTES:

- WEIGHTS SHOWN ARE FOR 48PG (HI HEAT) UNIT WITH ALUMINUM COILS AND STANDARD DRIVE. FOR WEIGHTS OF OPTIONAL EQUIPMENT CONSULT PRODUCT DATA BOOK.
- DO NOT LOCATE ADJACENT UNITS WITH FLUE DISCHARGE FACING ECONOMIZER INLET.
- MINIMUM CLEARANCE (LOCAL CODES OR JURISDICTIONS MAY PREVAIL):
  - FROM ROOF CURB TO TOP OF UNIT (8 INCHES WHEN USING ACCESSORY FLUE DISCHARGE DEFLECTOR)
  - WHEN NOT USING ROOF CURB (1 INCH) BOTTOM OF BASE PAN TO COMBUSTIBLE SURFACES.
  - WHEN NOT USING ROOF CURB (0 INCHES) TO BOTTOM OF BASE PAN TO COMBUSTIBLE SURFACES.
  - OVERHEAD (60 INCHES) TO ASSURE PROPER CONDENSER AIRFLOW.
  - BETWEEN UNITS, CONTROL BOX SIDE, 42 IN. PER NEC.
  - BETWEEN UNIT AND UNGRAUNDED SURFACE CONTROL BOX SIDE
  - FROM UNIT TO BLOCK OF CONCRETE WALL AND OTHER GROUNDED SURFACES CONTROL BOX SIDE (42 INCHES) PER NEC.
  - CLEARANCE IN FRONT OF INDOOR MOTOR ACCESS FOR BLOWER SLED REMOVAL 4' 6" COMPLETE CONDENSATE PAN REMOVAL 4' 8".
  - ON UNITS WITH ECONOMIZER AIRFLOW 3' 6" FROM LEFT SIDE FOR SERVICE ACCESS TO ECONOMIZER.
  - HORIZONTAL SUPPLY AND RETURN, (0 INCHES)
- DOWN SLOTT DUCTS DESIGNED TO BE ATTACHED TO ACCESSORY ROOF CURB. THIS UNIT IS NOT DESIGNED TO SUPPORT 1", 1 1/2" DUCTS. IF DUCTS MUST BE SUPPORTED BY CROSS BRACES AS DONE ON ACCESSORY ROOF CURB.
- DIMENSIONS IN ( ) ARE IN MILLIMETERS OR KILOGRAMS.
- WITH THE EXCEPTION OF CLEARANCE FOR THE CONDENSER COIL, COMBUSTIBLE SURFACES AND THE DAMPER/POWER EXHAUST AS STATED IN NOTE #2, A REMOVABLE FENCE OR BARRICADE REQUIRES NO CLEARANCE.
- DIMENSIONS ARE FROM OUTSIDE OF BASE PAIL. ALLOW 0 - 5/16 (8) ON EACH SIDE FOR TOP COVER DRIP EDGE.
- UNITS MAY BE INSTALLED ON COMBUSTIBLE FLOORS MADE FROM CLASS A-B-C ROOF COVERING MATERIAL IF SET ON BASE RAILS. CENTER OF GRAVITY

THIS DOCUMENT IS THE PROPERTY OF UNITED TECHNOLOGIES STRAKECO, NY. IT IS TO BE USED ONLY FOR THE PROJECT AND NOT BE REPRODUCED OR TRANSMITTED IN ANY FORM OR BY ANY MEANS, ELECTRONIC OR MECHANICAL, INCLUDING PHOTOCOPYING, RECORDING, OR BY ANY INFORMATION STORAGE AND RETRIEVAL SYSTEM. PERMISSION IS GRANTED TO MAKE A LIMITED NUMBER OF COPIES OF THIS DOCUMENT FOR PERSONAL OR INTERNAL USE ONLY. ALL OTHER RIGHTS ARE RESERVED. SUBMISSION OF THESE DRAWINGS OR DOCUMENTS DOES NOT CONSTITUTE AN ACCEPTANCE OF LIABILITY OR WARRANTY BY UNITED TECHNOLOGIES STRAKECO, NY.

UNIT	STD. WEIGHT (LBS.)	UNIT WEIGHT (LBS.)	CORNER WEIGHT (A) (LBS.)	CORNER WEIGHT (B) (LBS.)	CORNER WEIGHT (C) (LBS.)	CORNER WEIGHT (D) (LBS.)
50P603	704	319	162	73	142	64
50P604	704	319	162	73	142	64
50P605	775	352	178	81	156	71
50P606	829	376	191	86	167	76
50P607	874	396	201	91	176	80
50P605	775	352	178	81	156	71
50P606	829	376	191	86	167	76
50P607	874	396	201	91	176	80

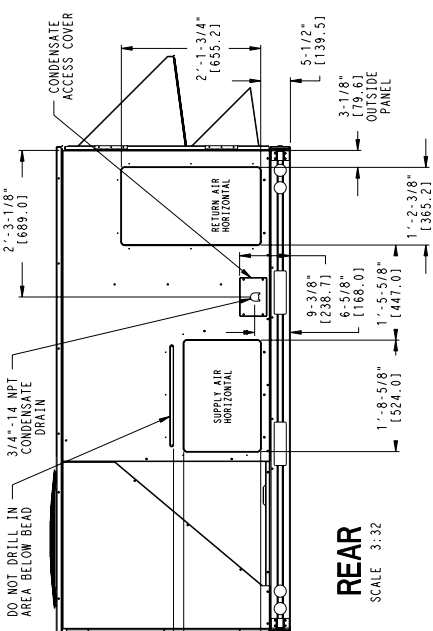
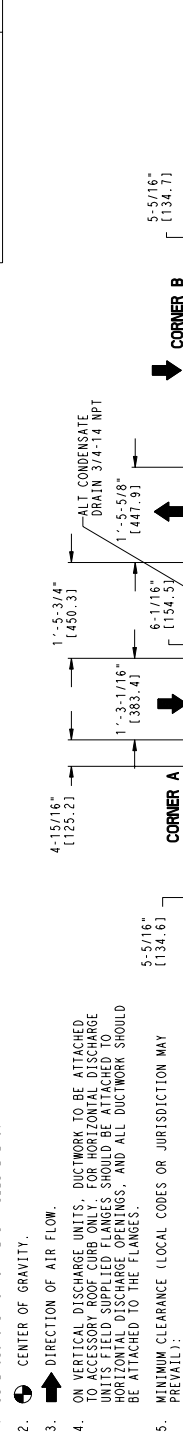

REAR  
 SCALE 3:32

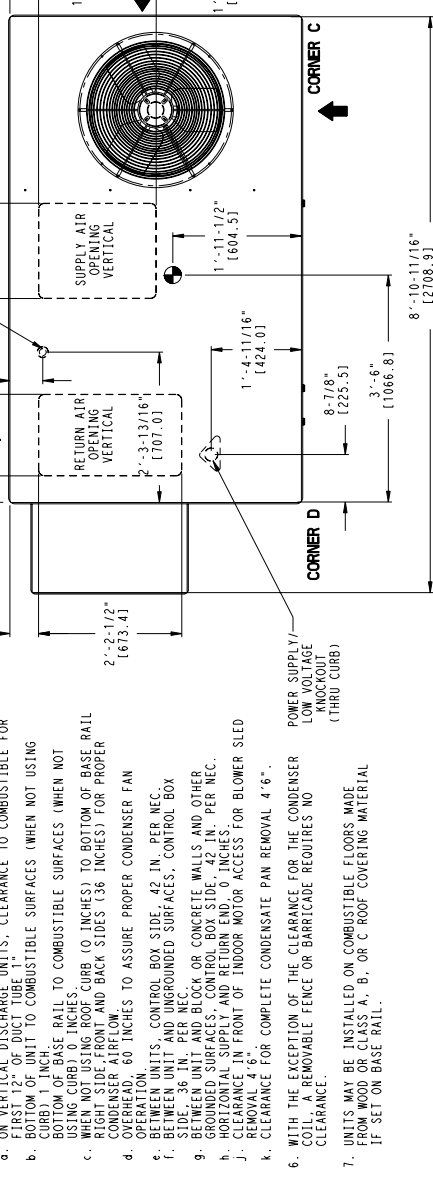

FRONT

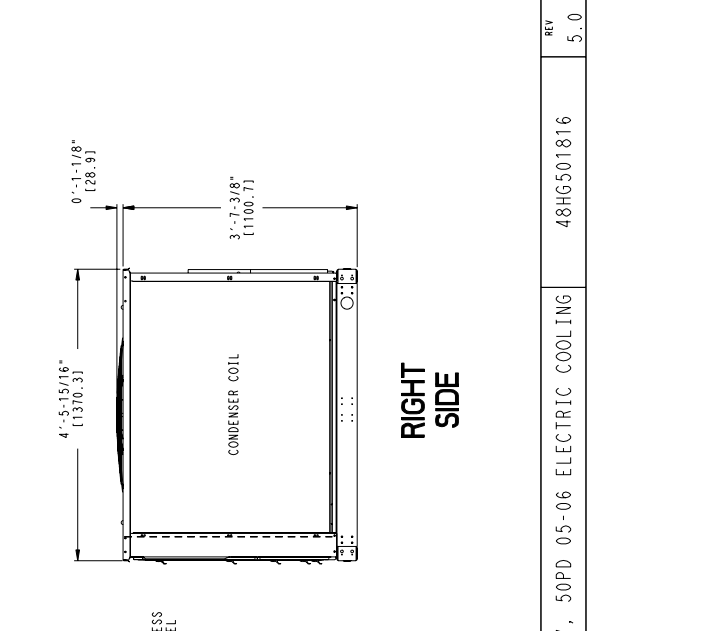

LEFT SIDE

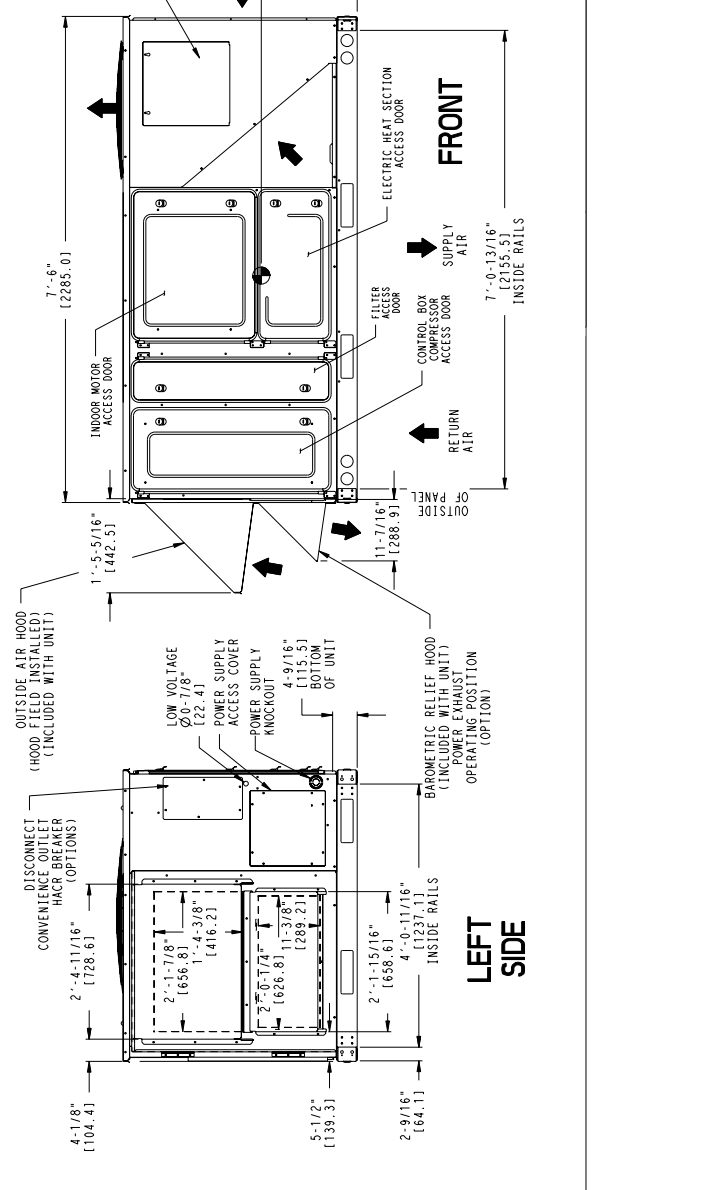

RIGHT SIDE

- NOTES:
- DIMENSIONS IN ( ) ARE IN MILLIMETERS.
  - CENTER OF GRAVITY.
  - DIRECTION OF AIR FLOW.
  - ON VERTICAL DISCHARGE UNITS, DUCTWORK TO BE ATTACHED TO ACCESSORY ROOF CURB ONLY. FOR HORIZONTAL DISCHARGE UNITS FIELD SUPPLIED FLANGES SHOULD BE ATTACHED TO HORIZONTAL DISCHARGE OPENINGS, AND ALL DUCTWORK SHOULD BE ATTACHED TO THE FLANGES.
  - MINIMUM CLEARANCE (LOCAL CODES OR JURISDICTION MAY PREVAIL):
    - ON VERTICAL DISCHARGE UNITS, CLEARANCE TO COMBUSTIBLE FOR FIRST 12" OF DUCT TUBE 1" (25.4).
    - BOTTOM OF UNIT TO COMBUSTIBLE SURFACES (WHEN NOT CURB) 1" (25.4).
    - ON BASE RAIL TO COMBUSTIBLE SURFACES (WHEN NOT CURB) 6" (152.4).
    - WHEN NOT USING ROOF CURB (0 INCHES) TO BOTTOM OF BASE RAIL:
      - RIGHT SIDE FRONT AND BACK SIDES (36 INCHES) FOR PROPER CONDENSER AIRFLOW.
      - OVERHEAD: 60 INCHES TO ASSURE PROPER CONDENSER FAN OPERATION.
      - BETWEEN UNITS: CONTROL BOX SIDE: 42 IN. PER NEC.
      - ON VERTICAL DISCHARGE UNITS: CONTROL BOX SIDE: 60 IN. PER NEC.
      - BETWEEN UNIT AND BLOCK OR CONCRETE WALLS AND OTHER GROUNDED SURFACES: CONTROL BOX SIDE: 42 IN. PER NEC.
      - HORIZONTAL SUPPLY AND RETURN END: 0 INCHES.
      - CLEARANCE IN FRONT OF INDOOR MOTOR ACCESS FOR BLOWER SLED REMOVAL: 4".
      - CLEARANCE FOR COMPLETE CONDENSATE PAN REMOVAL: 4".
    - WITH THE EXCEPTION OF THE CLEARANCE FOR THE CONDENSER COIL, A REMOVABLE FENCE OR BARRICADE REQUIRES NO CLEARANCE.
    - UNITS MAY BE INSTALLED ON COMBUSTIBLE FLOORS MADE FROM WOOD OR CLASS A, B, OR C ROOF COVERING MATERIAL IF SET ON BASE RAIL.



## 48/50PD SELECTION PROCEDURE

### I. Determine cooling and heating requirements at design conditions given the following data:

Vertical or Horizontal supply/return configuration  
Evaporator Air Quantity (CFM)  
External Duct Static Pressure (inwg)  
Electrical Characteristics (Volts-Ph-Hz)

#### Cooling

Required Gross Cooling Capacity (TC)  
Gross Sensible Capacity (SHC)  
Condenser Entering Air Temperature (OATc)  
Indoor Air (Return Air) Temperature (RATc)

#### Heating

Required Heating Capacity (HC)  
Ambient Air Temperature (OATh)  
Indoor Air (Return Air) Temperature (RATh)

### II. Select unit size

The unit size should be based on required cooling capacity at design conditions.

1. Using the design cooling data, enter the cooling capacity table (or software selection program) and determine the unit Total Cooling and Sensible Cooling Capacities.
2. Compare unit performance to required TC and SHC values.

**NOTE:** Unit ratings are gross capacities and do not include the effect of indoor fan motor heat. To calculate net capacities, see Step V.

### III. Select heating capacity

The unit heat option should be chosen to meet the heating requirements at the design conditions.

1. For gas heat units, utilize heat output values from the Gas Heating Capacities and Efficiencies table. Compare the heating output value to the design criteria. Calculate the heating leaving air temperature value using the formula:  
$$EAT = (\% RA)(RATh) + (\%OA)(OATh)$$
$$\text{Heat Output in BTU} = (CFM)(1.08)(EAT - LAT)$$
2. For electric heat units, compare the heating output value to the design criteria per the electric heater option for the desired electrical requirements (voltage-phase-hertz). Calculate the heating leaving air temperature value using the formula:  
$$EAT = (\% RA)(RATh) + (\%OA)(OATh)$$
$$(\text{Heat Output in Watts})(3.412) = (CFM)(1.08)(EAT - LAT)$$

### IV. Determine fan speed and power requirements at design conditions.

48/50PD units use the same fan performance tables as the similar size PG units. The variable fan system for a PD unit uses the 100% fan speed to satisfy the design cooling & heating capacities (same fan speed). The unit will modulate the fan system to lower speeds from that setting. See unit Application Data and Sequence of Operation sections of this manual for additional information.

1. Before entering the Fan Performance tables, calculate the total static pressure required due to duct design and any selected options/accessories.
2. Tabulated fan performance includes unit casing, filters, and wet evaporator coil. User only has to add effect of duct static pressure and options/accessories added to base unit. If using the software selection program, the options/accessory static pressure effects are automatically added in the selection software, so user only has to determine the appropriate duct static pressure.
3. Enter Fan Performance tables for the appropriate unit and determine the fan speed (RPM) and horsepower (bhp).
4. Compare fan speed and motor horsepower to speed ranges of each drive per the fan tables. If using the software selection program and more than one option is compatible with the desired operating point, the program will automatically default to the lower cost option.

### V. Determine net cooling capacities.

Listed cooling capacities are gross capacities and do not include indoor fan motor (IFM) heat. When desired, calculate the net cooling capacity as follows:

1. Determine input power to the motor, by entering the Fan Performance tables and determining the motor calculated input watts:  
$$\text{InputWatts} = (746 \times \text{Bhp}) / (\text{motor eff})$$
2. Determine net cooling capacity and net sensible cooling capacity using the following formulas:

$$\text{IFM Heat} = \text{Input Watts} \times 3.412 \text{ Btuh/Watt}$$

$$\text{Net Capacity} = \text{Gross Capacity} - \text{IFM Heat}$$

### VI. Select compatible controls & sensors.

The 48/50PD units cannot be operated using a conventional Y1/Y2 thermostat. A space temperature sensor must be used with or without a humidity or CO2 input.

**48PD05 AND 50PD05 (4 Tons) — MAXIMUM COOLING CAPACITY TABLE**

Condenser Air Temp (EdB)		Evaporator Entering Air (CFM)																	
		1200						1600						2000					
		Evaporator Entering wB (F)						Evaporator Entering wB (F)						Evaporator Entering wB (F)					
		80	72	67	62	58	54	80	72	67	62	58	54	80	72	67	62	58	54
60	TC	66.6	58.4	53.6	49.1	45.7	44.5	70.5	61.9	57	52.3	49.2	49.2	72.9	64.1	59.1	54.3	52.7	52.7
	SHC	18.3	27.8	33.8	39.6	43.4	44.5	18.6	31	38.6	45.8	49.2	49.2	18.7	33.7	42.7	51	52.7	52.7
	BF	0.00	0.00	0.24	0.22	0.23	0.37	0.00	0.27	0.23	0.23	0.30	0.47	0.00	0.26	0.24	0.25	0.39	0.55
70	TC	64.4	56.4	51.8	47.5	44.1	43.3	67.9	59.5	54.8	50.4	47.8	47.8	70	61.6	56.8	52.1	51.1	51.1
	SHC	17.6	27.2	33.2	38.9	42.3	43.3	17.8	30.2	37.8	45.1	47.8	47.8	17.9	32.8	41.9	49.7	51.1	51.1
	BF	0.00	0.36	0.22	0.20	0.24	0.39	0.00	0.25	0.22	0.22	0.31	0.49	0.00	0.25	0.24	0.26	0.41	0.56
75	TC	63.2	55.4	50.8	46.6	43.4	42.7	66.4	58.3	53.7	49.4	47	47	68.4	60.2	55.6	51.1	50.3	50.3
	SHC	17.2	26.9	32.8	38.6	41.8	42.7	17.4	29.8	37.3	44.7	47	47	17.5	32.4	41.4	49.1	50.3	50.3
	BF	0.00	0.29	0.22	0.20	0.24	0.40	0.00	0.24	0.22	0.22	0.33	0.50	0.00	0.25	0.24	0.27	0.42	0.57
85	TC	60.6	53.1	48.8	44.7	41.7	41.3	63.5	55.7	51.4	47.2	45.4	45.4	65.3	57.5	53.1	49	48.5	48.5
	SHC	16.3	26.1	32	37.7	40.3	41.3	16.5	28.9	36.5	43.6	45.4	45.4	16.6	31.4	40.5	47.6	48.5	48.5
	BF	0.00	0.26	0.20	0.19	0.27	0.41	0.00	0.23	0.21	0.22	0.35	0.51	0.00	0.24	0.23	0.28	0.44	0.58
95	TC	57.9	50.7	46.6	42.7	39.9	39.9	60.4	53.1	48.9	44.9	43.7	43.7	62	54.6	50.5	46.6	46.5	46.6
	SHC	15.5	25.2	31.2	36.8	39.9	39.9	15.6	28	35.5	42.4	43.7	43.7	15.7	30.5	39.5	46.6	46.5	46.6
	BF	0.00	0.23	0.19	0.19	0.24	0.43	0.00	0.22	0.21	0.22	0.37	0.53	0.00	0.23	0.23	0.28	0.46	0.60
105	TC	54.8	48	44.2	41.9	38.3	38.3	57	50.2	46.3	42.6	41.9	41.9	58.3	51.6	47.7	44.5	44.5	44.5
	SHC	14.5	24.3	30.2	31	38.3	38.3	14.6	27	34.5	41	41.9	41.9	14.7	29.5	38.4	44.2	44.5	44.5
	BF	0.00	0.21	0.18	0.18	0.27	0.45	0.00	0.21	0.21	0.23	0.40	0.55	0.00	0.23	0.23	0.32	0.48	0.61
115	TC	51.3	45.2	41.6	38.3	36.6	36.6	53.2	47.1	43.5	40.2	39.9	39.9	54.3	48.3	44.7	42.2	42.2	42.2
	SHC	13.5	23.2	29.2	34.9	36.6	36.6	13.5	25.9	33.4	39.3	39.9	39.9	13.6	28.3	37.3	42.2	42.2	42.2
	BF	0.00	0.19	0.18	0.18	0.30	0.48	0.00	0.21	0.20	0.26	0.42	0.57	0.00	0.23	0.23	0.34	0.51	0.63
125	TC	47.4	41.9	38.7	35.7	34.6	34.6	48.9	43.4	40.3	37.5	37.5	37.5	49.9	44.5	41.3	39.5	39.5	39.5
	SHC	12.3	22.1	28	33.5	34.6	34.6	12.3	24.7	32.2	37.5	37.5	37.5	12.4	27.1	35.9	39.5	39.5	39.5
	BF	0.00	0.18	0.17	0.18	0.34	0.50	0.00	0.20	0.20	0.27	0.46	0.59	0.01	0.22	0.23	0.38	0.54	0.66

**LEGEND**

- BF - Bypass Factor
- Edb - Entering Dry-Bulb
- Ewb - Entering Wet-Bulb
- kW - Compressor Motor Power Input
- ldb - Leaving Dry-Bulb
- lwb - Leaving Wet-Bulb
- SHC -- Sensible Heat Capacity (1000 Btuh) Gross
- TC - Total Capacity (1000 Btuh) Gross

**NOTES:**

1. Direct interpolation is permissible. Do not extrapolate.
2. The following formulas may be used:

$$t_{ldb} = t_{edb} - \frac{\text{sensible capacity (Btuh)}}{1.10 \times \text{cfm}}$$

$t_{lwb}$  = Wet-bulb temperature corresponding to enthalpy of air leaving evaporator coil ( $h_{lwb}$ )

$$h_{lwb} = h_{ewb} - \frac{\text{total capacity (Btuh)}}{4.5 \times \text{cfm}}$$

Where:  $h_{ewb}$  = Enthalpy of air entering evaporator coil

3. The SHC is based on 80F edb temperature of air entering evaporator coil. Below 80F edb, subtract (corr factor x cfm) from SHC. Above 80F edb, add (corr factor x cfm) to SHC.

BYPASS FACTOR (BF)	ENTERING AIR DRY-BULB TEMP (F)					
	79	78	77	76	75	under 75
	81	82	83	84	85	over 85
	Correction Factor					
.05	1.04	2.07	3.11	4.14	5.18	Use formula shown below.
.10	.98	1.96	2.94	3.92	4.90	
.20	.87	1.74	2.62	3.49	4.36	
.30	.76	1.53	2.29	3.05	3.82	

Interpolation is permissible.  
Correlation Factor =  $1.09 \times (1 - BF) \times (edb - 80)$ .

**48PD06 AND 50PD06 (5 Tons) — MAXIMUM COOLING CAPACITY TABLE**

Condenser Air Temp (EdB)	Evaporator Entering Air (CFM)																		
	1200						2000						2500						
	Evaporator Entering wB (F)						Evaporator Entering wB (F)						Evaporator Entering wB (F)						
	80	72	67	62	58	54	80	72	67	62	58	54	80	72	67	62	58	54	
60	TC	83.9	73.6	67.9	62.6	58.8	57.3	88.6	78.1	72.0	66.7	63.2	63.2	91.2	80.8	74.9	69.4	67.6	67.6
	SHC	23.0	35.7	43.4	51.1	55.7	57.2	23.4	39.9	49.6	59.3	63.1	63.1	23.5	43.2	55.3	65.6	67.5	67.5
	BF	0.00	0.17	0.16	0.16	0.20	0.37	0.00	0.17	0.17	0.18	0.29	0.47	0.00	0.20	0.19	0.22	0.39	0.55
70	TC	81.1	71.3	65.8	60.6	56.7	55.7	85.4	75.4	69.4	64.4	61.4	61.5	87.8	78.0	72.2	67.0	65.8	65.7
	SHC	22.1	34.9	42.6	50.1	54.2	55.6	22.5	38.8	48.6	58.1	61.4	61.4	22.6	42.2	54.2	64.1	65.7	65.7
	BF	0.00	0.16	0.16	0.16	0.21	0.39	0.00	0.17	0.17	0.18	0.31	0.49	0.00	0.20	0.19	0.23	0.41	0.56
75	TC	79.9	70.1	64.7	59.5	55.6	54.8	83.8	73.9	68.1	63.2	60.6	60.6	85.9	76.4	70.8	65.7	64.8	64.8
	SHC	21.7	34.4	42.1	49.4	53.6	54.8	22.0	38.3	48.1	57.5	60.5	60.5	22.0	41.7	53.6	63.3	64.7	64.7
	BF	0.00	0.16	0.16	0.16	0.21	0.40	0.00	0.17	0.17	0.18	0.32	0.50	0.00	0.20	0.19	0.24	0.42	0.57
85	TC	76.9	67.5	62.2	57.2	53.7	53.3	80.3	70.9	65.4	60.6	58.6	58.6	82.0	73.2	67.8	63.0	62.5	62.5
	SHC	20.8	33.5	41.1	48.7	52.0	53.2	21.0	37.2	46.8	56.0	58.5	58.6	20.9	40.6	52.3	61.4	62.5	62.5
	BF	0.00	0.15	0.15	0.15	0.23	0.42	0.00	0.17	0.18	0.19	0.34	0.52	0.00	0.20	0.20	0.25	0.44	0.58
95	TC	73.6	64.5	59.5	54.8	51.5	51.5	76.4	67.7	62.4	57.9	56.5	56.5	77.9	69.7	64.6	60.1	60.1	60.1
	SHC	19.7	32.4	40.1	47.4	51.4	51.4	19.8	36.1	45.9	54.6	56.4	56.4	19.8	39.4	51.2	60.0	60.0	60.1
	BF	0.00	0.15	0.15	0.16	0.23	0.44	0.00	0.17	0.17	0.20	0.37	0.53	0.00	0.20	0.19	0.26	0.46	0.60
105	TC	69.8	61.3	56.6	52.1	49.4	49.3	72.1	64.2	59.2	55.0	54.1	54.1	73.3	66.0	61.2	57.7	57.4	57.5
	SHC	18.6	31.2	38.9	46.2	49.3	49.3	18.6	34.8	44.6	52.8	54.1	54.1	18.5	38.1	49.9	56.2	57.4	57.4
	BF	0.00	0.15	0.15	0.15	0.26	0.46	0.00	0.17	0.17	0.21	0.39	0.55	0.00	0.20	0.20	0.31	0.48	0.62
115	TC	65.6	57.8	53.4	49.0	47.0	47.1	67.4	60.3	55.8	51.8	51.5	51.4	68.3	61.9	57.5	54.5	54.6	54.6
	SHC	17.3	30.0	37.7	44.8	47.0	47.0	17.3	33.5	43.2	50.5	51.4	51.4	17.2	36.7	48.4	54.5	54.5	54.5
	BF	0.00	0.15	0.14	0.15	0.30	0.49	0.00	0.17	0.17	0.23	0.42	0.57	0.00	0.20	0.20	0.33	0.51	0.64
125	TC	60.8	53.8	49.7	45.7	44.5	44.5	62.0	56.0	51.7	48.4	48.4	48.4	62.6	57.4	53.3	51.0	51.1	51.1
	SHC	15.9	28.5	36.1	42.9	44.4	44.5	15.8	32.0	41.6	47.8	48.3	48.3	15.6	35.0	46.7	51.0	51.0	51.0
	BF	0.00	0.15	0.14	0.17	0.34	0.51	0.00	0.18	0.17	0.27	0.46	0.60	0.00	0.21	0.20	0.38	0.54	0.66

**LEGEND**

- BF - Bypass Factor
- Edb - Entering Dry-Bulb
- Ewb - Entering Wet-Bulb
- kW - Compressor Motor Power Input
- ldb - Leaving Dry-Bulb
- lwb - Leaving Wet-Bulb
- SHC -- Sensible Heat Capacity (1000 Btuh) Gross
- TC - Total Capacity (1000 Btuh) Gross

**NOTES:**

1. Direct interpolation is permissible. Do not extrapolate.
2. The following formulas may be used:

$$t_{ldb} = t_{edb} - \frac{\text{sensible capacity (Btuh)}}{1.10 \times \text{cfm}}$$

$t_{lwb}$  = Wet-bulb temperature corresponding to enthalpy of air leaving evaporator coil ( $h_{lwb}$ )

$$h_{lwb} = h_{ewb} - \frac{\text{total capacity (Btuh)}}{4.5 \times \text{cfm}}$$

Where:  $h_{ewb}$  = Enthalpy of air entering evaporator coil

3. The SHC is based on 80F edb temperature of air entering evaporator coil. Below 80F edb, subtract (corr factor x cfm) from SHC. Above 80F edb, add (corr factor x cfm) to SHC.

BYPASS FACTOR (BF)	ENTERING AIR DRY-BULB TEMP (F)					
	79	78	77	76	75	under 75
	81	82	83	84	85	over 85
	Correction Factor					
.05	1.04	2.07	3.11	4.14	5.18	Use formula shown below.
.10	.98	1.96	2.94	3.92	4.90	
.20	.87	1.74	2.62	3.49	4.36	
.30	.76	1.53	2.29	3.05	3.82	

Interpolation is permissible.  
Correlation Factor =  $1.09 \times (1 - BF) \times (edb - 80)$ .

**INDOOR FAN DATA**

<b>48PD and 50PD Fan Motor and Drive Data Vertical Supply/Return</b>		
<b>UNIT SIZE</b>	<b>05</b>	<b>06</b>
<b>Voltage (volts)</b>	<b>208/230 and 460</b>	<b>208/230 and 460</b>
<b>LOW STATIC DRIVE OPTION</b>		
Motor HP	2.4	2.4
Motor Nominal RPM	1725	1725
Maximum Continuous BHP	2.0	2.0
Maximum Continuous Watts	2000	2000
Motor Frame Size	56HZ	56HZ
Motor shaft diameter (in.)	5/8	5/8
Motor Pulley Pitch Diameter Min - Max (in)	1.9 - 2.9	2.4 - 3.4
Fan RPM Range	596-910	690-978
Blower Pulley Pitch Diameter (in.)	5.5	6.0
Pulley center line distance (in.)	16.2-20.2	16.2-20.2
Belt Quantity / Type / Pitch Length (in.)	1- AX48- 49.3	1- AX48- 49.3
Speed change per turn of adjustable pulley (RPM)	63	58
Moveable pulley maximum full turns	5	5
Factory Speed setting (RPM)	596	690
<b>HIGH STATIC DRIVE OPTION</b>		
Motor HP	2.4	2.4
Motor Nominal RPM	1725	1725
Maximum Continuous BHP	2.0	2.0
Maximum Continuous Watts	2000	2000
Motor Frame Size	56HZ	56HZ
Motor shaft diameter (in.)	5/8	5/8
Motor Pulley Pitch Diameter Min - Max (in)	2.4 - 3.4	2.8 - 3.8
Fan RPM Range	828-1173	929-1261
Blower Pulley Pitch Diameter (in.)	5.0	5.2
Pulley center line distance (in.)	16.2-20.2	16.2-20.2
Belt Quantity - Type - Pitch Length (in.)	1- AX48- 49.3	1- AX48- 49.3
Speed change per turn of adjustable pulley (RPM)	69	67
Moveable pulley maximum full turns	5	5
Factory Speed setting (RPM)	828	929

<b>48PD and 50PD Fan Motor and Drive Data Horizontal Supply/Return</b>		
<b>UNIT SIZE</b>	<b>05</b>	<b>06</b>
<b>Voltage (volts)</b>	<b>208/230 and 460</b>	<b>208/230 and 460</b>
<b>LOW STATIC DRIVE OPTION</b>		
Motor HP	2.4	2.4
Motor Nominal RPM	1725	1725
Maximum Continuous BHP	2.0	2.0
Maximum Continuous Watts	2000	2000
Motor Frame Size	56HZ	56HZ
Motor shaft diameter (in.)	5/8	5/8
Motor Pulley Pitch Diameter Min - Max (in)	1.9 - 2.9	2.4 - 3.4
Fan RPM Range	596-910	690-978
Blower Pulley Pitch Diameter (in.)	5.5	6.0
Pulley center line distance (in.)	16.2-20.2	16.2-20.2
Belt Quantity / Type / Pitch Length (in.)	1- AX48- 49.3	1- AX48- 49.3
Speed change per turn of adjustable pulley (RPM)	63	58
Moveable pulley maximum full turns	5	5
Factory Speed setting (RPM)	596	690
<b>HIGH STATIC DRIVE OPTION</b>		
Motor HP	2.4	2.4
Motor Nominal RPM	1725	1725
Maximum Continuous BHP	2.0	2.0
Maximum Continuous Watts	2000	2000
Motor Frame Size	56HZ	56HZ
Motor shaft diameter (in.)	5/8	5/8
Motor Pulley Pitch Diameter Min - Max (in)	2.4 - 3.4	2.8 - 3.8
Fan RPM Range	828-1173	929-1261
Blower Pulley Pitch Diameter (in.)	5.0	5.2
Pulley center line distance (in.)	16.2-20.2	16.2-20.2
Belt Quantity - Type - Pitch Length (in.)	1- AX48- 49.3	1- AX48- 49.3
Speed change per turn of adjustable pulley (RPM)	69	67
Moveable pulley maximum full turns	5	5
Factory Speed setting (RPM)	828	929

**ELECTRICAL DATA**

**48PD 05 - 06 WITHOUT POWERED CONVENIENCE OUTLET**

48PD UNIT SIZE	NOMINAL POWER SUPPLY	VOLTAGE RANGE	COMP.		OFM		COMBUSTION FAN MOTOR (FLA)	Conv Outlet	PWR EXH (FLA)	IFM		POWER SUPPLY		DISCONNECT SIZE	
	Volts	Min-Max	RLA	LRA	Qty	FLA (ea)				TYPE	FLA	MCA	MOCP	FLA	LRA
05	208/230-3-60	187-253	16.1	110	1	1.0	0.52	none	-	STD	5.2	26.3/26.3	40/40	26/26	142/142
										ALT	5.2	26.3/26.3	40/40	26/26	142/142
									1.4	STD	5.2	27.7/27.7	40/40	27/27	144/144
										ALT	5.2	27.7/27.7	40/40	27/27	144/144
	460-3-60	414-506	7.8	52	1	0.5	0.30	none	-	STD	2.6	12.9	20	13	68
										ALT	2.6	12.9	20	13	68
									0.6	STD	2.6	13.5	20	13	69
										ALT	2.6	13.5	20	13	69

**48PD 05 - 06 WITH POWERED CONVENIENCE OUTLET**

48PD UNIT SIZE	NOMINAL POWER SUPPLY	VOLTAGE RANGE	COMP.		OFM		COMBUSTION FAN MOTOR (FLA)	Conv Outlet	PWR EXH (FLA)	IFM		POWER SUPPLY		DISCONNECT SIZE	
	Volts	Min-Max	RLA	LRA	Qty	FLA (ea)				TYPE	FLA	MCA	MOCP	FLA	LRA
05	208/230-3-60	187-253	16.1	110	1	1.0	0.52	YES	-	STD	5.2	31.1/31.1	45/45	31/31	147/147
										ALT	5.2	31.1/31.1	45/45	31/31	147/147
									1.4	STD	5.2	32.5/32.5	45/45	33/33	149/149
										ALT	5.2	32.5/32.5	45/45	33/33	149/149
	460-3-60	414-506	7.8	52	1	0.5	0.30	YES	-	STD	2.6	15.1	20	15	70
										ALT	2.6	15.1	20	15	70
									0.6	STD	2.6	15.7	20	16	71
										ALT	2.6	15.7	20	16	71

**Notes:**  
† Fuse or Breaker

ELECTRICAL DATA – CONT'D

50PD-05 WITHOUT POWERED CONVENIENCE OUTLET

50PD UNIT SIZE	NOMINAL POWER SUPPLY Volt-Ph-Hz	VOLTAGE RANGE	COMP.		OFM		CONV OUTLET	PWR EXH	IFM		ELECTRIC HEAT			POWER SUPPLY		Single point kit	DISCONNECT SIZE	
			Min-Max	RLA	LRA	Qty			FLA	FLA (ea)	TYPE	FLA	Part Number	FLA	Nom. kW		MCA	MOCP
05	208/230-3-60	187-253	16.1	110	1	1.0	none	-	STD	5.2	-	-	-	26.3/26.3	40/40	-	26/26	142/142
											CRHEATER208A00	10.0/11.5	3.8/5.0	26.3/26.3	40/40	-	26/26	142/142
											CRHEATER209A00	15.0/17.3	5.6/7.5	26.3/28.1	40/40	-	26/26	142/142
											CRHEATER210A00	20.0/23.1	7.5/10.0	31.5/35.4	40/40	-	29/33	142/142
											CRHEATER211A00	30.0/34.6	11.3/15.0	44.0/49.8	45/50	-	40/46	142/142
											CRHEATER212A00	40.0/46.2	15.0/20.0	56.5/64.3	60/70	031	52/59	142/142
											-	-	-	26.3/26.3	40/40	-	26/26	142/142
											CRHEATER208A00	10.0/11.5	3.8/5.0	26.3/26.3	40/40	-	26/26	142/142
											CRHEATER209A00	15.0/17.3	5.6/7.5	26.3/28.1	40/40	-	26/26	142/142
											CRHEATER210A00	20.0/23.1	7.5/10.0	31.5/35.4	40/40	-	29/33	142/142
											CRHEATER211A00	30.0/34.6	11.3/15.0	44.0/49.8	45/50	-	40/46	142/142
											CRHEATER212A00	40.0/46.2	15.0/20.0	56.5/64.3	60/70	031	52/59	142/142
	460-3-60	414-506	7.8	52	1	0.5	none	-	STD	2.6	-	-	-	27.7/27.7	40/40	-	27/27	144/144
											CRHEATER208A00	10.0/11.5	3.8/5.0	27.7/27.7	40/40	-	27/27	144/144
											CRHEATER209A00	15.0/17.3	5.6/7.5	27.7/29.9	40/40	-	27/27	144/144
											CRHEATER210A00	20.0/23.1	7.5/10.0	33.3/37.1	40/40	-	31/34	144/144
											CRHEATER211A00	30.0/34.6	11.3/15.0	45.8/51.5	50/60	-	42/47	144/144
											CRHEATER212A00	40.0/46.2	15.0/20.0	58.3/66.0	60/70	031	54/61	144/144
											-	-	-	27.7/27.7	40/40	-	27/27	144/144
											CRHEATER208A00	10.0/11.5	3.8/5.0	27.7/27.7	40/40	-	27/27	144/144
											CRHEATER209A00	15.0/17.3	5.6/7.5	27.7/29.9	40/40	-	27/27	144/144
											CRHEATER210A00	20.0/23.1	7.5/10.0	33.3/37.1	40/40	-	31/34	144/144
											CRHEATER211A00	30.0/34.6	11.3/15.0	45.8/51.5	50/60	-	42/47	144/144
											CRHEATER212A00	40.0/46.2	15.0/20.0	58.3/66.0	60/70	031	54/61	144/144
460-3-60	414-506	7.8	52	1	0.5	none	-	STD	2.6	-	-	-	12.9	20	-	13	68	
										CRHEATER215A00	5.8	5.0	12.9	20	-	13	68	
										CRHEATER216A00	8.7	7.5	14.1	20	-	13	68	
										CRHEATER217A00	11.5	10.0	17.6	20	-	16	68	
										CRHEATER218A00	17.3	15.0	24.9	25	-	23	68	
										CRHEATER219A00	23.1	20.0	32.1	35	-	30	68	
										-	-	-	12.9	20	-	13	68	
										CRHEATER215A00	5.8	5.0	12.9	20	-	13	68	
										CRHEATER216A00	8.7	7.5	14.1	20	-	13	68	
										CRHEATER217A00	11.5	10.0	17.6	20	-	16	68	
										CRHEATER218A00	17.3	15.0	24.9	25	-	23	68	
										CRHEATER219A00	23.1	20.0	32.1	35	-	30	68	
460-3-60	414-506	7.8	52	1	0.5	none	-	STD	2.6	-	-	-	13.5	20	-	13	69	
										CRHEATER215A00	5.8	5.0	13.5	20	-	13	69	
										CRHEATER216A00	8.7	7.5	14.9	20	-	14	69	
										CRHEATER217A00	11.5	10.0	18.4	20	-	17	69	
										CRHEATER218A00	17.3	15.0	25.6	30	-	24	69	
										CRHEATER219A00	23.1	20.0	32.9	35	-	30	69	
										-	-	-	13.5	20	-	13	69	
										CRHEATER215A00	5.8	5.0	13.5	20	-	13	69	
										CRHEATER216A00	8.7	7.5	14.9	20	-	14	69	
										CRHEATER217A00	11.5	10.0	18.4	20	-	17	69	
										CRHEATER218A00	17.3	15.0	25.6	30	-	24	69	
										CRHEATER219A00	23.1	20.0	32.9	35	-	30	69	

ELECTRICAL DATA – CONT'D

50PD-06 WITHOUT POWERED CONVENIENCE OUTLET

50PD UNIT SIZE	NOMINAL POWER SUPPLY Volt-Ph-Hz	VOLTAGE RANGE Min-Max	COMP.		OFM		CONV OUTLET	PWR EXH FLA (ea)	IFM		ELECTRIC HEAT			POWER SUPPLY		Single point kit	DISCONNECT SIZE	
			RLA	LRA	Qty	FLA			TYPE	FLA	Part Number	FLA	Nom. KW	MCA	MOCP		FLA	LRA
06	208/230-3-60	187-253	17.9	110	1	1.5	none	-	STD	5.2	-	-	-	29.1/29.1	45/45	-	28/28	143/143
											CRHEATER208A00	10.0/11.5	3.8/5.0	29.1/29.1	45/45	-	28/28	143/143
											CRHEATER209A00	15.0/17.3	5.6/7.5	29.1/29.1	45/45	-	28/28	143/143
											CRHEATER210A00	20.0/23.1	7.5/10.0	31.5/35.4	45/45	-	29/33	143/143
											CRHEATER211A00	30.0/34.6	11.3/15.0	44.0/49.8	45/50	-	40/46	143/143
											CRHEATER212A00	40.0/46.2	15.0/20.0	56.5/64.3	60/70	031	52/59	143/143
									CRHEATER213A00	50.0/57.7	18.8/25.0	69.0/78.6	70/80	031	63/72	143/143		
									ALT	5.2	-	-	-	29.1/29.1	45/45	-	28/28	143/143
											CRHEATER208A00	10.0/11.5	3.8/5.0	29.1/29.1	45/45	-	28/28	143/143
											CRHEATER209A00	15.0/17.3	5.6/7.5	29.1/29.1	45/45	-	28/28	143/143
											CRHEATER210A00	20.0/23.1	7.5/10.0	31.5/35.4	45/45	-	29/33	143/143
											CRHEATER211A00	30.0/34.6	11.3/15.0	44.0/49.8	45/50	-	40/46	143/143
	CRHEATER212A00	40.0/46.2	15.0/20.0	56.5/64.3	60/70	031	52/59	143/143										
	CRHEATER213A00	50.0/57.7	18.8/25.0	69.0/78.6	70/80	031	63/72	143/143										
	STD	5.2	-	-	-	30.5/30.5	45/45	-	30/30	145/145								
			CRHEATER208A00	10.0/11.5	3.8/5.0	30.5/30.5	45/45	-	30/30	145/145								
			CRHEATER209A00	15.0/17.3	5.6/7.5	30.5/30.5	45/45	-	30/30	145/145								
			CRHEATER210A00	20.0/23.1	7.5/10.0	33.3/37.1	45/45	-	31/34	145/145								
			CRHEATER211A00	30.0/34.6	11.3/15.0	45.8/51.5	50/60	-	42/47	145/145								
			CRHEATER212A00	40.0/46.2	15.0/20.0	58.3/66.0	60/70	031	54/61	145/145								
	CRHEATER213A00	50.0/57.7	18.8/25.0	70.8/80.4	80/90	031	65/74	145/145										
	ALT	5.2	-	-	-	30.5/30.5	45/45	-	30/30	145/145								
			CRHEATER208A00	10.0/11.5	3.8/5.0	30.5/30.5	45/45	-	30/30	145/145								
			CRHEATER209A00	15.0/17.3	5.6/7.5	30.5/30.5	45/45	-	30/30	145/145								
CRHEATER210A00			20.0/23.1	7.5/10.0	33.3/37.1	45/45	-	31/34	145/145									
CRHEATER211A00			30.0/34.6	11.3/15.0	45.8/51.5	50/60	-	42/47	145/145									
CRHEATER212A00			40.0/46.2	15.0/20.0	58.3/66.0	60/70	031	54/61	145/145									
CRHEATER213A00	50.0/57.7	18.8/25.0	70.8/80.4	80/90	031	65/74	145/145											
06	460-3-60	414-506	7.8	52	1	0.8	none	-	STD	2.6	-	-	-	13.2	20	-	13	69
											CRHEATER215A00	5.8	5.0	13.2	20	-	13	69
											CRHEATER216A00	8.7	7.5	14.1	20	-	13	69
											CRHEATER217A00	11.5	10.0	17.6	20	-	16	69
											CRHEATER218A00	17.3	15.0	24.9	25	-	23	69
											CRHEATER219A00	23.1	20.0	32.1	35	-	30	69
									CRHEATER220A00	28.9	25.0	39.4	40	-	36	69		
									ALT	2.6	-	-	-	13.2	20	-	13	69
											CRHEATER215A00	5.8	5.0	13.2	20	-	13	69
	CRHEATER216A00	8.7	7.5	14.1	20	-	13	69										
	STD	2.6	-	-	-	13.8	20	-	14	70								
			CRHEATER215A00	5.8	5.0	13.8	20	-	14	70								
			CRHEATER216A00	8.7	7.5	14.9	20	-	14	70								
			CRHEATER217A00	11.5	10.0	18.4	20	-	17	70								
			CRHEATER218A00	17.3	15.0	25.6	30	-	24	70								
			CRHEATER219A00	23.1	20.0	32.9	35	-	30	70								
	CRHEATER220A00	28.9	25.0	40.1	45	-	37	70										
	ALT	2.6	-	-	-	13.8	20	-	14	70								
CRHEATER215A00			5.8	5.0	13.8	20	-	14	70									
CRHEATER216A00			8.7	7.5	14.9	20	-	14	70									
CRHEATER217A00	11.5	10.0	18.4	20	-	17	70											
CRHEATER218A00	17.3	15.0	25.6	30	-	24	70											
CRHEATER219A00	23.1	20.0	32.9	35	-	30	70											
CRHEATER220A00	28.9	25.0	40.1	45	-	37	70											

ELECTRICAL DATA – CONT'D

50PD-05 WITH POWERED CONVENIENCE OUTLET

50PD UNIT SIZE	NOMINAL POWER SUPPLY Volt-Ph-Hz	VOLTAGE RANGE Min-Max	COMP.		OFM		CONV OUTLET	PWR EXH FLA (ea)	IFM		ELECTRIC HEAT			POWER SUPPLY		Single point kit	DISCONNECT SIZE	
			RLA	LRA	Qty	FLA			TYPE	FLA	Part Number	FLA	Nom. KW	MCA	MOCP		FLA	LRA
05	208/230-3-60	187-253	16.1	110	1	1.0	YES	-	STD	5.2	none	-	-	31.1/31.1	45/45	-	31/31	147/147
											CRHEATER208A00	10.0/11.5	3.8/5.0	31.1/31.1	45/45	-	31/31	147/147
											CRHEATER209A00	15.0/17.3	5.6/7.5	31.3/34.1	45/45	-	31/31	147/147
											CRHEATER210A00	20.0/23.1	7.5/10.0	37.5/41.4	45/45	-	35/38	147/147
											CRHEATER211A00	30.0/34.6	11.3/15.0	50.0/55.8	60/60	-	46/51	147/147
											CRHEATER212A00	40.0/46.2	15.0/20.0	62.5/70.3	70/80	031	58/65	147/147
									ALT	5.2	none	-	-	31.1/31.1	45/45	-	31/31	147/147
											CRHEATER208A00	10.0/11.5	3.8/5.0	31.1/31.1	45/45	-	31/31	147/147
											CRHEATER209A00	15.0/17.3	5.6/7.5	31.3/34.1	45/45	-	31/31	147/147
											CRHEATER210A00	20.0/23.1	7.5/10.0	37.5/41.4	45/45	-	35/38	147/147
											CRHEATER211A00	30.0/34.6	11.3/15.0	50.0/55.8	60/60	-	46/51	147/147
											CRHEATER212A00	40.0/46.2	15.0/20.0	62.5/70.3	70/80	031	58/65	147/147
	460-3-60	414-506	7.8	52	1	0.5	YES	-	STD	2.6	none	-	-	15.1	20	-	15	70
											CRHEATER215A00	5.8	5.0	15.1	20	-	15	70
											CRHEATER216A00	8.7	7.5	16.9	20	-	16	70
											CRHEATER217A00	11.5	10.0	20.4	25	-	19	70
											CRHEATER218A00	17.3	15.0	27.6	30	-	25	70
											CRHEATER219A00	23.1	20.0	34.9	35	-	32	70
									ALT	2.6	none	-	-	15.1	20	-	15	70
											CRHEATER215A00	5.8	5.0	15.1	20	-	15	70
											CRHEATER216A00	8.7	7.5	16.9	20	-	16	70
											CRHEATER217A00	11.5	10.0	20.4	25	-	19	70
											CRHEATER218A00	17.3	15.0	27.6	30	-	25	70
											CRHEATER219A00	23.1	20.0	34.9	35	-	32	70
STD	2.6	none	-	-	15.7	20	-	16	71									
		CRHEATER215A00	5.8	5.0	15.7	20	-	16	71									
		CRHEATER216A00	8.7	7.5	17.6	20	-	16	71									
		CRHEATER217A00	11.5	10.0	21.1	25	-	19	71									
		CRHEATER218A00	17.3	15.0	28.4	30	-	26	71									
		CRHEATER219A00	23.1	20.0	35.6	40	-	33	71									
ALT	2.6	none	-	-	15.7	20	-	16	71									
		CRHEATER215A00	5.8	5.0	15.7	20	-	16	71									
		CRHEATER216A00	8.7	7.5	17.6	20	-	16	71									
		CRHEATER217A00	11.5	10.0	21.1	25	-	19	71									
		CRHEATER218A00	17.3	15.0	28.4	30	-	26	71									
		CRHEATER219A00	23.1	20.0	35.6	40	-	33	71									

ELECTRICAL DATA – CONT'D

50PD-06 WITH POWERED CONVENIENCE OUTLET

50PD UNIT SIZE	NOMINAL POWER SUPPLY Volt-Ph-Hz	VOLTAGE RANGE	COMP.		OFM		CONV OUTLET	PWR EXH FLA (ea)	IFM		ELECTRIC HEAT			POWER SUPPLY		Single point kit	DISCONNECT SIZE		
			Min-Max	RLA	LRA	Qty			FLA	TYPE	FLA	Part Number	FLA	Nom. kW	MCA		MOCP	FLA	LRA
06	208/230-3-60	187-253	16.1	110	1	1.0	YES	-	STD	5.2	none	-	-	33.9/33.9	50/50	-	34/34	148/148	
											CRHEATER208A00	10.0/11.5	3.8/5.0	33.9/33.9	50/50	-	34/34	148/148	
											CRHEATER209A00	15.0/17.3	5.6/7.5	33.9/34.1	50/50	-	34/34	148/148	
											CRHEATER210A00	20.0/23.1	7.5/10.0	37.5/41.4	50/50	-	35/38	148/148	
											CRHEATER211A00	30.0/34.6	11.3/15.0	50.0/55.8	60/60	-	46/51	148/148	
											CRHEATER212A00	40.0/46.2	15.0/20.0	62.5/70.3	70/80	031	58/65	148/148	
									CRHEATER213A00	50.0/57.7	18.8/25.0	75.0/84.6	80/90	031	69/78	148/148			
									ALT	5.2	none	-	-	33.9/33.9	50/50	-	34/34	148/148	
											CRHEATER208A00	10.0/11.5	3.8/5.0	33.9/33.9	50/50	-	34/34	148/148	
											CRHEATER209A00	15.0/17.3	5.6/7.5	33.9/34.1	50/50	-	34/34	148/148	
											CRHEATER210A00	20.0/23.1	7.5/10.0	37.5/41.4	50/50	-	35/38	148/148	
											CRHEATER211A00	30.0/34.6	11.3/15.0	50.0/55.8	60/60	-	46/51	148/148	
	CRHEATER212A00	40.0/46.2	15.0/20.0	62.5/70.3	70/80	031	58/65	148/148											
	CRHEATER213A00	50.0/57.7	18.8/25.0	75.0/84.6	80/90	031	69/78	148/148											
	460-3-60	414-506	7.8	52	1	0.5	YES	-	STD	2.6	none	-	-	15.4	20	-	15	71	
											CRHEATER215A00	5.8	5.0	15.4	20	-	15	71	
											CRHEATER216A00	8.7	7.5	16.9	20	-	16	71	
											CRHEATER217A00	11.5	10.0	20.4	25	-	19	71	
											CRHEATER218A00	17.3	15.0	27.6	30	-	25	71	
											CRHEATER219A00	23.1	20.0	34.9	35	-	32	71	
									CRHEATER220A00	28.9	25.0	42.1	45	-	39	71			
									ALT	2.6	none	-	-	15.4	20	-	15	71	
											CRHEATER215A00	5.8	5.0	15.4	20	-	15	71	
											CRHEATER216A00	8.7	7.5	16.9	20	-	16	71	
CRHEATER217A00											11.5	10.0	20.4	25	-	19	71		
CRHEATER218A00											17.3	15.0	27.6	30	-	25	71		
CRHEATER219A00	23.1	20.0	34.9	35	-	32	71												
CRHEATER220A00	28.9	25.0	42.1	45	-	39	71												
460-3-60	414-506	7.8	52	1	0.5	YES	-	STD	2.6	none	-	-	16.0	20	-	16	72		
										CRHEATER215A00	5.8	5.0	16.0	20	-	16	72		
										CRHEATER216A00	8.7	7.5	17.6	20	-	16	72		
										CRHEATER217A00	11.5	10.0	21.1	25	-	19	72		
										CRHEATER218A00	17.3	15.0	28.4	30	-	26	72		
										CRHEATER219A00	23.1	20.0	35.6	40	-	33	72		
								CRHEATER220A00	28.9	25.0	42.9	45	-	39	72				
								ALT	2.6	none	-	-	16.0	20	-	16	72		
										CRHEATER215A00	5.8	5.0	16.0	20	-	16	72		
										CRHEATER216A00	8.7	7.5	17.6	20	-	16	72		
										CRHEATER217A00	11.5	10.0	21.1	25	-	19	72		
										CRHEATER218A00	17.3	15.0	28.4	30	-	26	72		
CRHEATER219A00	23.1	20.0	35.6	40	-	33	72												
CRHEATER220A00	28.9	25.0	42.9	45	-	39	72												

# 24V CONTROL SCHEMATIC 48PD C05-C06 COMFORTLINK

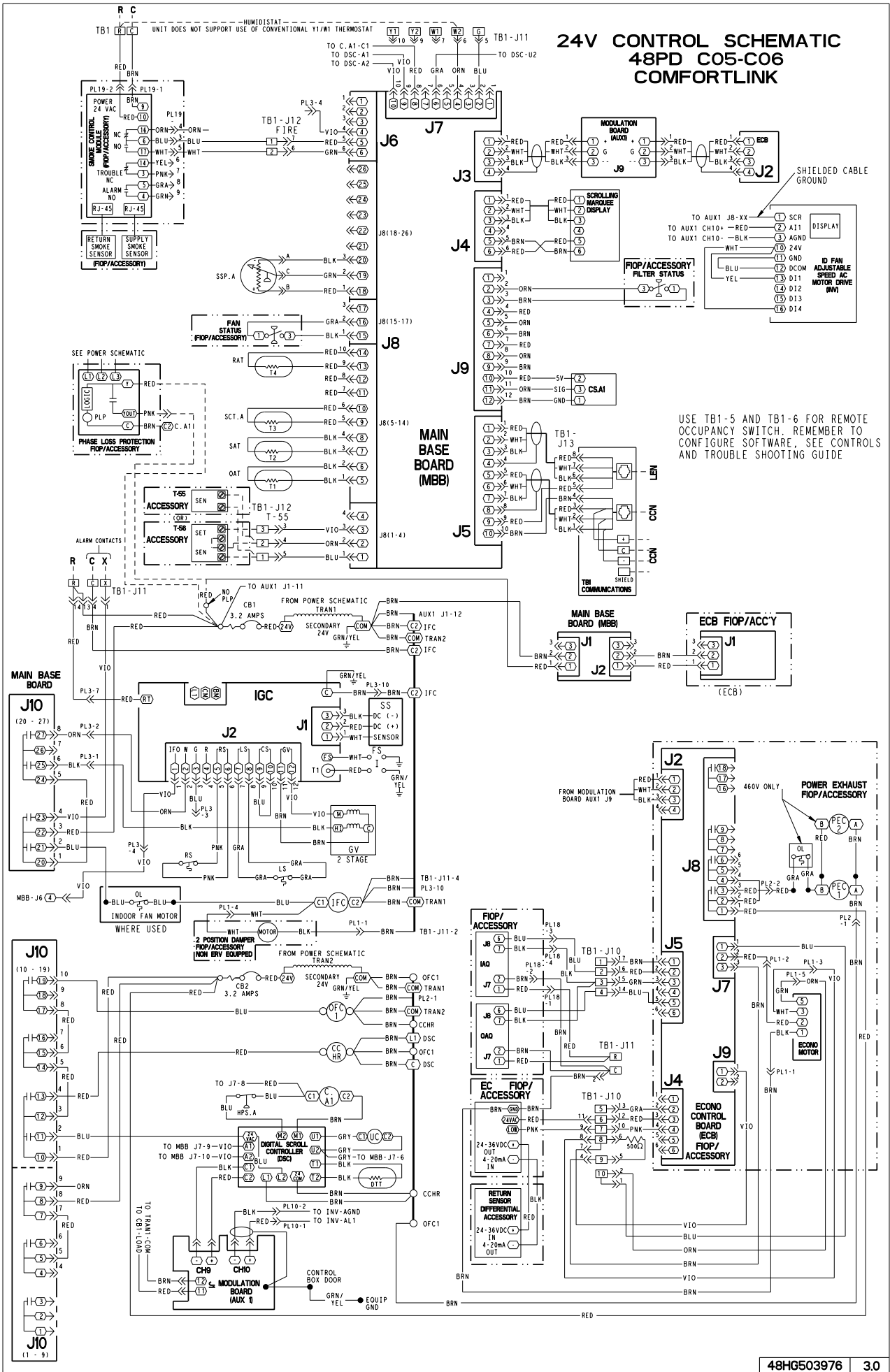

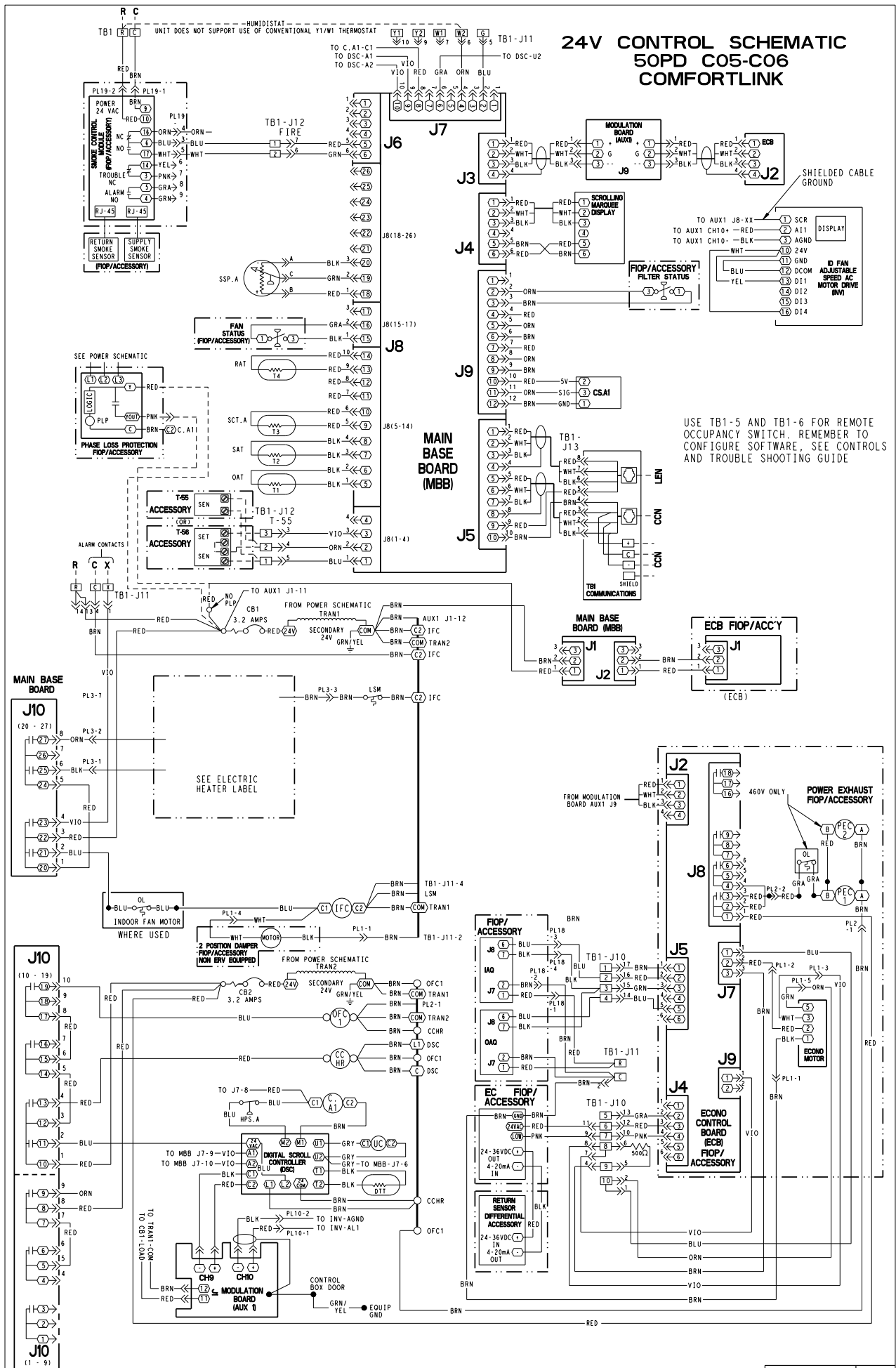

**POWER SCHEMATIC 48/50 PD.C05,C06 208/230,460-3-60 COMFORTLINK**

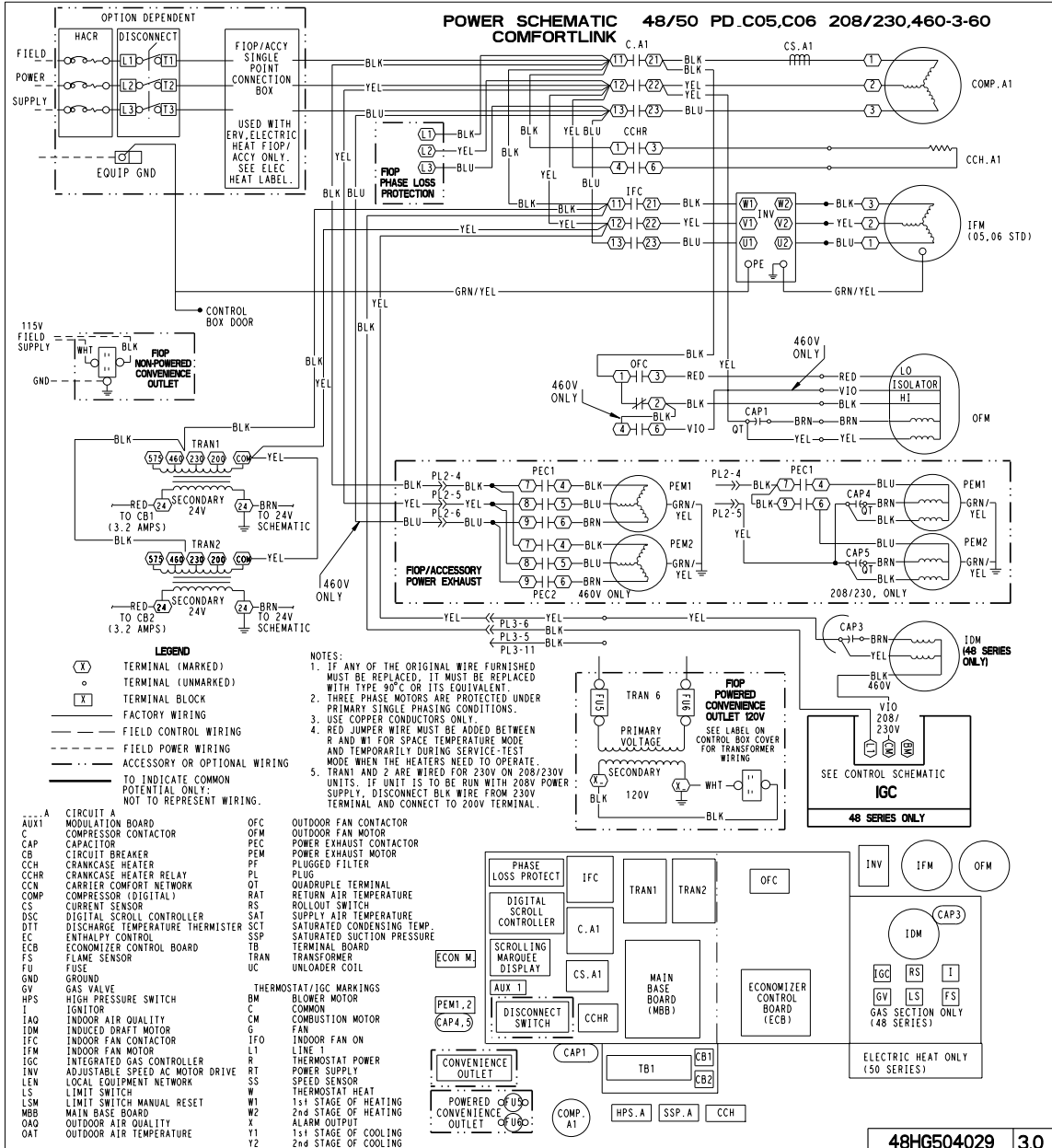

- LEGEND**
- (X) TERMINAL (MARKED)
  - o TERMINAL (UNMARKED)
  - [X] TERMINAL BLOCK
  - FACTORY WIRING
  - FIELD CONTROL WIRING
  - FIELD POWER WIRING
  - ACCESSORY OR OPTIONAL WIRING
  - TO INDICATE COMMON POTENTIAL ONLY; NOT TO REPRESENT WIRING.

- NOTES:**
1. IF ANY OF THE ORIGINAL WIRE FURNISHED MUST BE REPLACED, IT MUST BE REPLACED WITH TYPE 90°C OR ITS EQUIVALENT.
  2. THREE PHASE MOTORS ARE PROTECTED UNDER PRIMARY SINGLE PHASING CONDITIONS.
  3. USE COPPER CONDUCTORS ONLY.
  4. RED JUMPER WIRE MUST BE ADDED BETWEEN R AND W1 FOR SPACE TEMPERATURE MODE AND TEMPORARILY DURING SERVICE-TEST MODE WHEN THE HEATERS NEED TO OPERATE.
  5. TRAN1 AND 2 ARE WIRED FOR 230V ON 208/230V UNITS. IF UNIT IS TO BE RUN WITH 208V POWER SUPPLY, DISCONNECT BLK WIRE FROM 230V TERMINAL AND CONNECT TO 200V TERMINAL.

<ul style="list-style-type: none"> <li>AUX1 MODULATION BOARD</li> <li>C COMPRESSOR CONTACTOR</li> <li>CAP CAPACITOR</li> <li>CB CIRCUIT BREAKER</li> <li>CCH CRANKCASE HEATER</li> <li>CCN CARRIER COMFORT NETWORK</li> <li>COMP COMPRESSOR (DIGITAL)</li> <li>CS CURRENT SENSOR</li> <li>DSC DIGITAL SCROLL CONTROLLER</li> <li>DTT DISCHARGE TEMPERATURE THERMISTOR</li> <li>EC ENTHALPY CONTROL</li> <li>ECB ECONOMIZER CONTROL BOARD</li> <li>FS FLAME SENSOR</li> <li>FU FUSE</li> <li>GND GROUND</li> <li>GV GAS VALVE</li> <li>HPS HIGH PRESSURE SWITCH</li> <li>I IGNITOR</li> <li>IAQ INDOOR AIR QUALITY</li> <li>IDM INDUCED DRAFT MOTOR</li> <li>IFC INDOOR FAN CONTACTOR</li> <li>IFM INDOOR FAN MOTOR</li> <li>IGC INTEGRATED GAS CONTROLLER</li> <li>INV ADJUSTABLE SPEED AC MOTOR DRIVE</li> <li>LS LOCAL EQUIPMENT NETWORK</li> <li>LSM LIMIT SWITCH</li> <li>LSM LIMIT SWITCH MANUAL RESET</li> <li>MBB MAIN BASE BOARD</li> <li>OAQ OUTDOOR AIR QUALITY</li> <li>OAT OUTDOOR AIR TEMPERATURE</li> </ul>	<ul style="list-style-type: none"> <li>OFC OUTDOOR FAN CONTACTOR</li> <li>OFM OUTDOOR FAN MOTOR</li> <li>PEC POWER EXHAUST CONTACTOR</li> <li>PEM POWER EXHAUST MOTOR</li> <li>PF PLUGGED FILTER</li> <li>PL PLUS</li> <li>PLUG QUADRUPLE TERMINAL</li> <li>RAT RETURN AIR TEMPERATURE</li> <li>RS ROLLOUT SWITCH</li> <li>SAT SUPPLY AIR TEMPERATURE</li> <li>SCT SATURATED CONDENSING TEMP.</li> <li>SSP SATURATED SUCTION PRESSURE</li> <li>TB TERMINAL BOARD</li> <li>TRAN TRANSFORMER</li> <li>UC UNLOADER COIL</li> </ul>	<ul style="list-style-type: none"> <li>THERMOSTAT/IGC MARKINGS</li> <li>BM BLOWER MOTOR</li> <li>C COMMON</li> <li>CM COMBUSTION MOTOR</li> <li>G FAN</li> <li>IFO INDOOR FAN ON</li> <li>LINE 1 LINE 1</li> <li>R THERMOSTAT POWER</li> <li>RT POWER SUPPLY</li> <li>SS SPEED SENSOR</li> <li>W THERMOSTAT HEAT</li> <li>W1 1st STAGE OF HEATING</li> <li>W2 2nd STAGE OF HEATING</li> <li>X ALARM OUTPUT</li> <li>Y1 1st STAGE OF COOLING</li> <li>Y2 2nd STAGE OF COOLING</li> </ul>
---	---	---

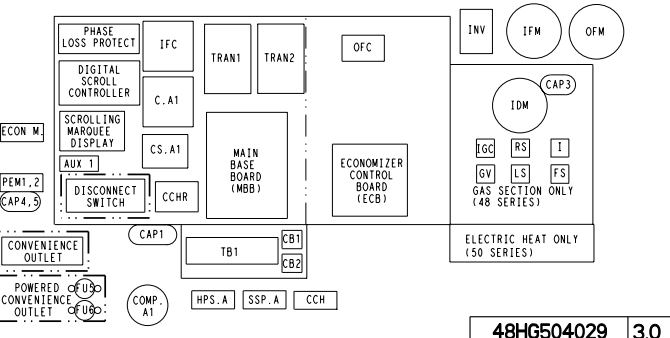

## 48/50PD Sequence of Operation

### GENERAL

The 48PD and 50PD rooftop units use Puron® (R-410A) refrigerant and ComfortLink™ DDC controls. The PD units are intended to be used in either a displacement ventilation or a single-zone variable air volume application. The PD unit includes a factory installed variable capacity compressor and variable frequency drive indoor fan motor. The unit is controlled by space temperature via space temperature sensor T-55, T-56 or T58 and will not operate with a conventional R, Y1, Y2, W1, W2, G, C thermostat. When a T-55, T-56 or T58 space temperature sensor is connected to the low voltage terminal board as shown in the Installation Instructions Manual, the unit will try to maintain the Space Temperature (SPACE\_T) at one of four set points:

- Occupied Cool Set Point (OCSF)
- Unoccupied Cool Set Point (UCSF)
- Occupied Heat Set Point (OHSP)
- Unoccupied Heat Set Point (UHSP)

The building's occupancy is affected by a number of different factors (see Controls and Troubleshooting Guide for details). When the building is in occupied mode, the occupied set points are active. When the building is in unoccupied mode, the unoccupied set points are active. The unit controls will switch automatically between cooling and heating to maintain temperature. However, to minimize unnecessary cool to heat and heat to cool changes, there is a 10 minute delay after the last stage turns off before the control will switch modes.

NOTE: Use of a supply air pressure input to control the Centurion PD unit to a constant supply air pressure value is not supported nor recommended. The space temperature sensor is a thermistor input to the main base board. Electrical input to the main control board

(MBB) is a resistance value corresponding to a temperature in the space. This input will only respond to resistance of the device connected to it. A free pressure transducer input is available on the MBB and there are also pressure transducer inputs on the AUX1 board. However, use of these inputs from a supply air pressure sensor will not be interpreted by the ComfortLink in the desired manner and consequently, proper unit control will not be achieved.

### Cooling Mode Using Space Temperature Sensors: T55, T56, or T58 (No Economizer)

In the cooling mode, the unit will maintain the Occupied Cool Set Point (OCSF) (or the Unoccupied Cool Set Point (UCSF)) by modulating the indoor fan speed to supply more or less airflow to the conditioned space. The compressor will modulate to maintain the supply air temperature at the Cool Supply Air Set Point. Additional factors such as humidity control (Cooling Supply Air Reset), economizer usage, Demand Control Ventilation and ventilate mode can also affect this sequence.

**Cooling Supply Air Set Point** - The Cool Supply Air Set Point can be configured between 45F and 75F. The compressor will modulate to maintain a Supply Air Temperature at the Cool Supply Air Set Point (SASF).

**Cooling Demand Window** - The PD unit indoor fan is controlled via Cooling Demand Window fan speed logic sequence. See Figure 1. When the temperature in the conditioned space is higher than the Occupied Cool Set Point (OCSF) plus the Fan Speed Control Demand (SPEEDDMD) configuration variable (or Unoccupied Cool Set Point (UCSF) plus the Fan Speed Control Demand (SPEEDDMD) configuration variable) the indoor fan will run at 100%. When the temperature in the conditioned space is between the Occupied Cool Set Point (OCSF) and Occupied Cool Set Point (OCSF) plus the Fan Speed Control Demand (SPEEDDMD) configuration variable the indoor fan modulates to satisfy the Occupied Cool Set Point (OCSF) or Unoccupied Cool Set Point (UCSF). When the temperature in the conditioned space falls to 0.5F below the Occupied Cool Set Point (OCSF) or Unoccupied Cool Set Point (UCSF) for 5 minutes the controls will run unit in ventilation mode. See ventilation mode sequence of operation for details on this mode.

**Cooling Supply Air Set Point Reset** - The PD unit can be configured to allow for reset of the Cool Supply Air Set Point (SASF). This is needed for applications where a high Cool Supply Air Set Point (SASF) is required or where dramatic load changes occur over short time periods. In these situations a high supply air temperature may not provide enough cooling to reduce the Space Temperature (SPACE\_T) to the Occupied Cool Set Point (OCSF) or the Unoccupied Cool Set Point (UCSF) over a reasonable time period.

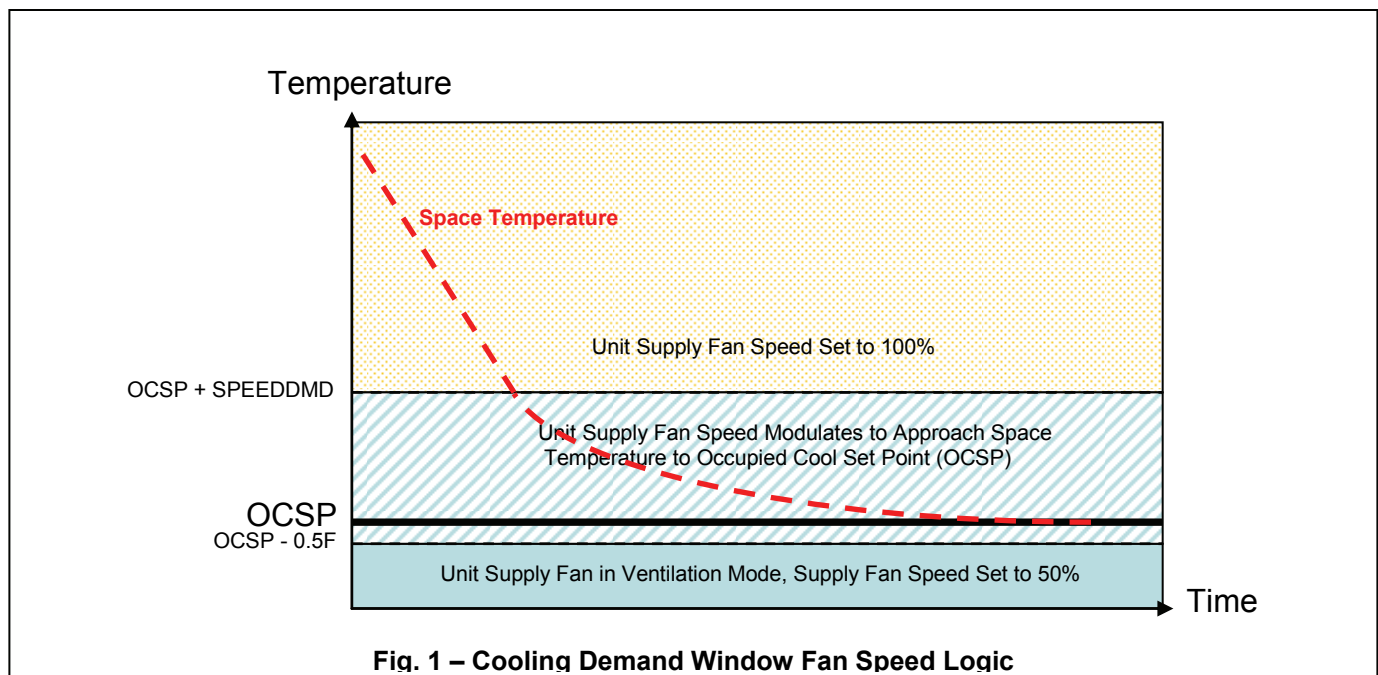

Reset of the Cooling Supply Air Set Point is set by the configuration variables SASP Maximum Reset Down (SASPMAXD) and SASP Maximum Reset Up (SASPMAXU).

The SASP Maximum Reset Down (SASPMAXD) configuration variable can be set from -20 to 0 F and will allow the Supply Air Temperature to be Reset to as much as 20 F below the Cool Supply Air Set Point (SASP).

The SASP Maximum Reset Up (SASPMAXU) configuration variable can be set from 0 to 20 F and will allow the Supply Air Temperature to be Reset to as much as 20 F above the Cool Supply Air Set Point (SASP).

These two configuration variables can be set independently and do not need to be equal values above and below the Supply Air Set Point. For example, the SASP Maximum Reset Down (SASPMAXD) configuration variable can be set to -10 and the SASP Maximum Reset Up (SASPMAXU) configuration variable can be set to 0 giving the range of Cool Supply Air Set Point (SASP) reset of +0 and -10 F. See Figure 2.

In normal operation when the Space Temperature (SPACE\_T) is within the speed demand window the unit control will modulate the indoor fan speed and supply air temperature along a defined curve to bring the Space Temperature to Occupied or Unoccupied Cool Set Point (OCSP or UCSP). Since this curve is independent of the conditioned space load the control scheme will adapt to any load present in the conditioned space by adjusting the fan speed and supply air temperature and move the space temperature along the defined time temperature curve to Occupied or Unoccupied Cool Set Point (OCSP OR UCSP).

When the space temperature rises above the Occupied Cool Set Point + Speed Demand (OCSP + SPEEDDMD) for over 2 minutes or is outside the speed demand window and there is some amount of SASP Maximum Reset Down (SASPMAXD) configured the indoor fan will be locked at 100% and the unit controls will subtract a calculated amount of temperature reset to the Supply Air Set Point (SASP). The indoor fan speed will be locked at 100% as long as reset is applied. The Supply Air Temperature will now adjust to this new control point. The controls will continue to subtract a calculated amount of temperature reset cumulatively to a value equal to the Supply Air Temperature Set Point – SASP Maximum Reset Down (SASP+SASPMAXD). When the reset is no longer needed the

the Supply Air Temperature Control Point is back to the original Supply Air Set Point (SASP). The indoor fan will then modulate lower than 100% to move the space temperature along the defined time temperature curve to Occupied or Unoccupied Cool Set Point (OCSP OR UCSP).

### Cooling Mode with Economizer Using Space Temperature Sensor T55, T56, or T58

When the space temperature is above the Occupied Cool Set Point (OCSP) and the economizer is installed, the unit controls will always try to meet space cooling demand using the economizer before turning on a compressor, per the ASHRAE 90.1 requirement for energy efficient integrated economizer operation. The economizer will provide free cooling when the following outside air conditions are true.

Condition 1 - For all units with Economizers, the outdoor temperature is below the Econo Cool Hi Temp Limit (EH.LO) and above the Econo Cool Lo Temp Limit (EL.LO).

Condition 2 - For units with Enthalpy Control, the outdoor enthalpy is low and the outdoor temperature is below the Econo Cool Hi Temp Limit (EH.LO) and above the Econo Cool Lo Temp Limit (EL.LO).

If the conditions above are not true, the economizer will move to the Configurable Economizer Minimum Position (MP.xx) where MP.xx selects the minimum economizer damper position based on the indoor fan speed. This is done to maintain a constant airflow through the economizer by opening the dampers more as the indoor fan speed is reduced. The shape of the Economizer Minimum Position vs. Fan Speed curve is determined by the configuration parameters: Econ Min at Min Fan speed (MP.MN), Econ Min at 25% Fan speed (MP.25), Econ Min at 50% Fan speed (MP.50), Econ Min at 75% Fan speed (MP.75), Econ Min at Max Fan speed (MP.MX) and Econo Cool Max Position (MAX.P). The compressor will turn on and supply cooling to the conditioned space. See Figure 3.

If the economizer is available for cooling but it is unable to cool the conditioned space, the compressor will turn on and provide additional cooling to the conditioned space.

If the indoor fan is not operating, the economizer will be closed.

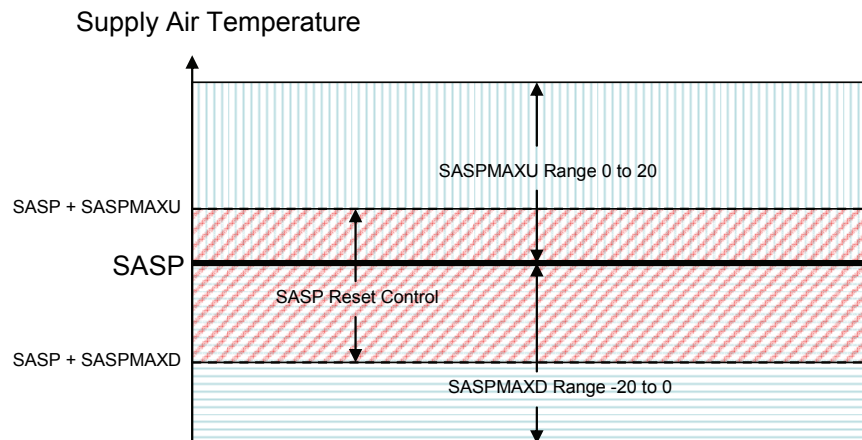

Fig. 2 – Cooling Supply Air Set Point Reset

control will remove Down Reset to until all reset is removed and

### Cooling Mode Using Space Temperature Sensor T55, T56 or T58 and Humidistat

Enhanced dehumidification can be provided when a humidistat (HL38MG029, TSTATCCPLH01-B or 33CS2PPRH-01) is connected. When the humidistat contacts close and provide a 24VAC signal, the unit will reset the supply air temperature by one degree F lower than the Supply Air Set Point (SASP) or the current control point if the Supply Air Set Point has already been modified. After 5 minutes if the humidistat contacts are still closed and 24 VAC is being supplied to the W2 terminal the PD unit will reset the supply air temperature lower by one more degree F. This reset cycle will continue to lower the supply air temperature every 5 minutes until the supply air temperature control point is equal to the Supply Air Set Point + SASP Maximum Reset Down ((SASP+SASPMAXD). The unit will continue to operate at this reduced supply air temperature control point until the humidistat contacts open and 24VAC is no longer supplied to the W2 terminal.

When the dehumidification signal is no longer supplied, the supply air control point will be reset higher by one degree F, in 3 minute intervals until the supply air temperature control point is equal to the Supply Air Set Point (SASP) or the supply air control point if reset was being applied due to cooling requirements that reset the Supply Air Set Point (SASP).

Whenever the Relative Humidity Reset is applied, the space temperature is controlled by modulating the fan speed even if the fan was locked at 100% due to SASP reset.

### Cooling Mode Using Space Temperature Sensor T55, T56, or T58 and Humidity Sensor

Enhanced dehumidification can be provided when a humidity sensor (HL39ZZ007 or 33ZCSENHRH-01) is connected. When the relative humidity in the space is above the relative humidity set point the PD unit controls will reset the supply air per the same logic as described for a humidistat above.

### Ventilation Mode

When the space temperature falls 0.5F below the Occupied Cool Set Point (OCSP) the compressor will turn off, the indoor fan speed will be set to 50% and the economizer will open to the position that will supply minimum ventilation air at 50% fan speed.

### Demand Control Ventilation

The PD units can also be equipped with optional CO2 sensors for additional indoor air quality control using a Demand Control Ventilation system. Consult the Controls and Troubleshooting Guide for more information on IAQ features.

### Heating Mode Using Space Temperature Sensor T55, T56, or T58

In heating mode the PD unit will maintain the Occupied Heat Set Point (OHSP) or the Unoccupied Heat Set Point (UHSP) by turning on or off the Stage 1 and Stage 2 Heat at 100% indoor fan speed. For units with an economizer, the outdoor air damper stays at the Economizer Minimum Position while the evaporator fan is operating and shuts when the indoor fan is off.

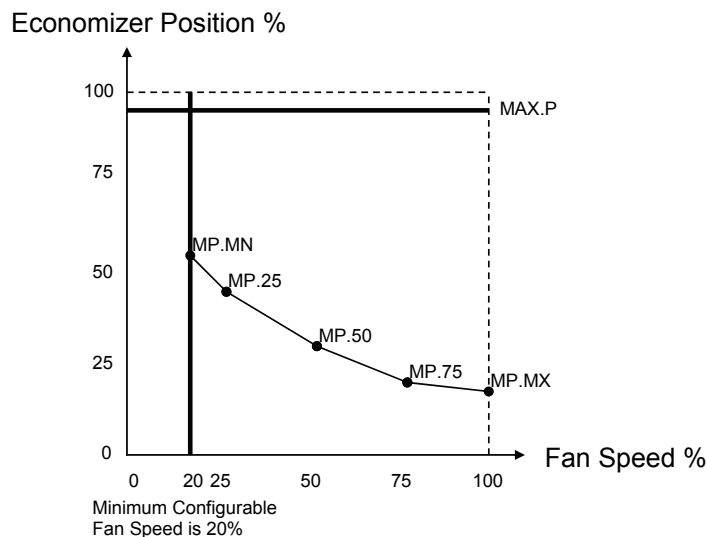

Fig. 3 – Economizer Logic

## APPLICATION DATA

### Ductwork

Ductwork should be attached to the curb on all units. Ductwork should NOT be attached to the unit. Interior installation may be placed before unit is set in place on roof.

### Thru-the-Bottom Service Connections

Roof curb connections allow field power wires and control wires to enter through the roof curb opening and bottom of unit through the removable plate in the bottom of the compressor compartment.

### Space Temperature Sensor

A space temperature sensor is required for all units.

### Airflow

Units are draw-thru for cooling and blow-thru for heating.

### Maximum Airflow

The maximum unit airflow is 500 cfm/nominal ton.

### Minimum Airflow

The minimum design airflow for cooling is 300 cfm/nominal ton. Operation Air Quantity Limits table for minimum airflow cfm for heating. The PD unit will modulate the fan speed up/down from the design value according the logic in the sequence of operation.

**IMPORTANT:** The minimum heating cfm must be maintained to ensure proper operation in the Heating mode. The minimum heating cfm value takes precedence over the minimum cooling cfm value.

### Minimum Ambient Cooling Operation Temperature

All units with *ComfortLink* controls are designed to allow operation down to ambient outdoor temperatures of 0°F.

### Maximum Operating Outdoor--Air Temperature

For cooling, the maximum operating ambient temperature is 125°F.

### High Altitude

A change to the gas orifice may be required at high altitudes. Refer to Altitude Compensation charts.

### Minimum Heating Entering Air Temperature

For operation with heat exchanger entering air temperatures below 50°F continuous / 45°F intermittent, a stainless steel heat exchanger is strongly recommended.

Additionally, a field-supplied outdoor air thermostat is recommended to initiate both stages of heat when the entering air is below the following limits:

Aluminized Steel: 50°F continuous / 45°F intermittent

Stainless Steel: 40°F continuous / 35°F intermittent

This will minimize cold air dumping into the space due to initiating both stages of heat for full fire operation. Wire the outdoor air thermostat (part no. HH22AG106) in series with the second stage gas valve as shown below. Set the outdoor air thermostat at 35°F for stainless steel heat exchangers or 45°F for aluminum heat exchangers.

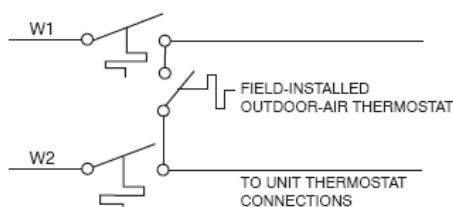

C07529

### Sizing a PD Rooftop Unit

The Centurion PD rooftop unit utilizes variable compressor loading and variable fan speed to modulate the rooftop unit's capacity from full design capacity down to part-load requirements.

Bigger is not necessarily better. While an air conditioner needs to have enough capacity to meet the design loads, excess capacity results in poor part-load performance and humidity control. Using higher design temperatures than ASHRAE recommends for your location and adding "safety factors" to the calculated load, are all signs of over-sizing air conditioners.

Over-sizing the air conditioner leads to poor humidity control, reduced efficiency, higher utility bills, larger indoor temperature swings, excessive noise, and increased wear and tear on the air conditioner. Rather than over-sizing an air conditioner, designers should "right-size" or even slightly undersize air conditioners. Correctly sizing an air conditioner results in better control of space humidity, promotes efficiency, reduces utility bills, extends equipment life, and maintains even, comfortable temperatures. Please contact your local Carrier representative for further assistance.

### Outdoor Air Application Strategies

Any of the following devices can be used for outdoor/ventilation air: manual damper, two position damper, economizer or an energy recovery device.

#### Manual and Two Position Dampers

Manual and two position dampers increase the load and operating expense on the RTU because they are fixed and not variable. Additionally, these devices will contribute to unsatisfactory space conditioning because they will not modulate with the changing outdoor air conditions.

#### Economizers

As promulgated by ASHRAE, economizers reduce operating expenses and compressor run time by providing a source of free cooling and a means of ventilation to match changing application needs. When properly designed (per ASHRAE standards), the economizer will control the amount of outdoor air allowed into the building and is integrated with the operation of the compressors.

Carrier economizers are properly designed and allow free cooling to occur when the outdoor air is suitable depending upon the control strategy chosen. As a result, they should be considered for most applications in lieu of manual or two position dampers. It has also been proven (by multiple sources) that using economizers with a Demand Control Ventilation (CO<sub>2</sub>) strategy will result in considerable energy savings over a manual damper, two-position damper or no damper applications.

#### Energy Recovery Device

Energy recovery devices typically result in substantial energy savings over other outdoor air devices. They typically add sensible and latent capacity, and additional stages of cooling and heating operation to the unit. Due to the variable capacity compressor and fan system, care must be taken when incorporating an energy recovery unit with a Centurion PD unit. The energy recovery fan operation must be controlled in conjunction with the varying speed of the RTU fan.

Please contact your local Carrier representative for further assistance.

## Low Ambient Applications

In most low ambient cooling situations, the optional Carrier economizer can adequately cool the space by bringing in low temperature outside air. In fact, when an economizer is used, accessory low-ambient kits are typically not necessary. Additionally, unless the outdoor air is excessively contaminated, economizer based “free cooling” is the preferred less costly and energy conscious method of low ambient cooling.

In low ambient applications where outside air might not be desired (such as contaminated air applications), a head pressure control device can control the condenser head pressure to allow compressor operation down to ambient temperatures of 0F. Please contact your local Carrier representative for further assistance in choosing an appropriate low ambient device.

## Condenser Coil Protection (Enviro-Shield™)

**Pre-coated aluminum--fin coils** have a durable epoxyphenolic coating applied to the fin prior to the fin stamping process to provide protection in mildly corrosive coastal environments.

Pre-coated coils have an inert barrier between the aluminum fin and copper tube. This barrier electrically disconnects the dissimilar metals to minimize the potential for galvanic corrosion. This economical option provides substantial corrosion protection for mild coastal environments beyond the standard uncoated coil construction.

**Copper-fin coils** provide increased corrosion resistance in moderate coastal environments where industrial air pollution is not present. All copper coils eliminate bi--metallic construction to eliminate the potential for galvanic corrosion. Use of copper fin coils in industrial environments is not recommended due to potential attack from sulfur, sulfur oxide, nitrogen oxides, carbon and several other industrial air--borne contaminants. In moderate seacoast environments, copper--fin coils have extended life compared to standard or pre--coated aluminum-fin coils.

**E-Coated aluminum-fin coils** undergo a precisely controlled scientific process that bonds an impermeable epoxy coating to the specially prepared fin coil surface. E-Coating produces a smooth, consistent coating that is less brittle, more resilient and more durable than previous post coating processes. E-Coated aluminum-fin coils offer economical protection and improved coil life in industrial and combined coastal and industrial environments.

**E-Coated copper-fin coils** provide maximum protection in virtually all environments, this option combines the continuous, impenetrable barrier of the E-Coating process with the natural resistance of an all-copper construction. E-Coated copper-fin coil assemblies ensure long life in severe coastal conditions.

## Indoor Air Quality

An indoor air quality sensor, which senses CO<sub>2</sub>, is a factory-installed option. The sensor in conjunction with the economizer is used to maintain indoor air quality. By selecting this option, the minimum economizer position can be reduced because the control will adjust economizer position to maintain indoor air quality to the desired set point. A wall-mounted indoor air quality sensor is a field-installed accessory.

## Enthalpy Sensor

Enthalpy switches are available as field-installed accessories. If only one switch is used, it is used to measure return air enthalpy. If two switches are used they should be wired in a differential configuration to measure the difference in the return and outdoor enthalpies. The enthalpy switches signify when the outdoor air is suitable for free cooling.

## Plugged Filter Indicator

A plugged filter indicator (filter status switch) is available as a factory-installed option and a field-installed accessory. By measuring the pressure differential across the evaporator section, it signals when the evaporator filters should be cleaned.

## Fan Status

A fan status switch is available as a factory--installed option and a field--installed accessory. By sensing the pressure differential generated by the indoor fan, it signals the *ComfortLink* system when the indoor fan blower is operating and therefore it is very useful for detecting broken belts, etc.

## GUIDE SPECIFICATIONS

### 48PD - Packaged Rooftop Electric Cooling Unit with Gas Heat Variable Capacity, Variable Air Volume Cooling Constant Air Volume Heating with Puron R-R410A Refrigerant and COMFORTLink™ Controls

#### Cooling Size Range:

4 to 5 Tons, Nominal Cooling  
48,000 to 60,000 BTUH

#### Heating Size Range:

35,700 to 121,500 MBtuh (Gas heat output)

#### Carrier Model Numbers: 48PD

### Part 1 — General

#### 1.01 SYSTEM DESCRIPTION

Outdoor only, rooftop mounted, electrically controlled, heating and cooling unit utilizing fully hermetic digital scroll compressors with on demand crankcase heaters for cooling duty and induced draft gas combustion for heating duty. Supply air shall be discharged downward or horizontally. Supply air fan system shall be a variable air flow design to deliver a variable quantity and temperature of air to meet the space cooling and heating demand. Controls shall adjust supply air quantity and temperature to adapt to conditioned space load demand. Units shall be of ultra high cooling efficiency and utilize environmentally friendly Puron (R-410A) refrigerant.

#### 1.02 QUALITY ASSURANCE

- A. Unit shall well exceed ASHRAE 90.1-2004 and ENERGY STAR efficiency standards. SEER shall be as high as 15.
- B. Unit shall be rated in accordance with ARI Standards 210.
- C. Units shall be designed in accordance with UL Standard 1995. Unit shall be UL and UL Canada, tested as a total package.
- D. Unit shall be rated in accordance with ARI sound standards 270.
- E. Unit shall be designed to conform to ASHRAE 15.
- F. Roof curb shall be designed to conform to NRCA Standards.
- G. Insulation and adhesive shall meet NFPA 90A requirements for flame spread and smoke generation.
- H. Unit casing shall be capable of withstanding 500-hour salt spray exposure per ASTM B117 (scribed specimen).
- I. Unit shall be manufactured in a facility registered to ISO 9001:2000.
- J. Each unit shall be subjected to a completely automated run testing on the assembly line.

#### 1.03 DELIVERY, STORAGE, AND HANDLING

Unit shall be stored and handled per manufacturer's recommendations.

### Part 2 — Products

#### 2.01 EQUIPMENT (STANDARD)

##### A. General

The unit shall be a fully factory assembled, pre-tested, single-piece heating and cooling unit. Contained within the unit enclosure shall be all factory wiring, piping, controls, Puron refrigerant charge (R-410A), and all special features required prior to field start-up.

##### B. Unit Cabinet

1. Constructed of galvanized steel, bonderized and coated with a pre-painted baked enamel finish on all externally exposed surfaces. Internal surfaces shall be of a primer coated finish.
2. All air stream interior surfaces shall be insulated with a minimum 1/2-in. thick, 1 lb density foil faced cleanable insulation. Insulation shall be bonded with a thermosetting resin (8 to 12% by weight nominal, phenol formaldehyde typical), and coated with an acrylic or other material that meets the NFPA 90 flame retardance requirements and has an "R" value of 3.70. Insulation shall also be encapsulated with panel design or tape edges ensuring secure fit.
3. Cabinet panels shall be hinged with integrated non-corrosive hinges. Large area hinged access panels for the filter, compressors, evaporator fan, and control box and heat section areas. Each panel shall use multiple quarter-turn latches and handles. Each major external hinged access panel shall be double-wall construction and permanently attached to the rooftop unit. Panels shall also include tiebacks.
4. Return air filters shall be accessible through a dedicated hinged access panel and be on a slide-out track using standard size filters. Filter shall be standard off the shelf sizes and be the size per cabinet. Capability for 2 or 4 inch filters shall be on all sizes.
5. Holes shall be provided in the base rails (minimum 16 gauge) for rigging shackles and level travel and movement during overhead rigging operations.
6. Fork lift slots shall be available from three sides of the unit (end and 2 sides).
7. Unit shall have a factory--installed internally sloped condensate drain pan, providing a minimum 3/4--in.—14 NPT connection to prevent standing water from accumulating. Pan shall be fabricated of high impact polycarbonate material and shall slide out for cleaning and or maintenance. An alternate vertical drain (3/4-in. NPT) connection shall also be available. All drain pans conform to ASHRAE 62 self draining provisions.
8. Unit shall have standard thru-the-bottom power and control wiring connection capability.

##### C. Fans

1. Indoor blower (evaporator fan):
  - a. Centrifugal supply air blower shall have rubber--isolated, cartridge type ball bearings and adjustable belt drive.
  - b. Fan wheel shall be made from steel with a corrosion resistant finish. It shall be a dynamically balanced, double--inlet type with forward--curved blades.
  - c. The indoor fan system (blower wheels, motors, belts, and both bearings) shall slide out for easy access.
  - d. Evaporator--fan motors shall be continuous operation, open drip--proof. Bearings shall be sealed, permanently lubricated ball bearing type for longer life and lower maintenance.
  - e. Fan belt shall be located on opposite side of evaporator coil to prevent damage from broken fan belts.
  - f. Evaporator fan motor Adjustable Speed AC drive -- shall follow the provisions of UL 508C, shall have casing material rated for plenum use, shall control the motor from 20% to 100% of the 60Hz speed with input signal derived from the space temperature. AC drive shall have a display for setting drive parameters that can be mounted remote from the AC drive.
2. Condenser fans shall be of the direct-driven propeller type, with corrosion-resistant aluminum blades riveted to corrosion-resistant steel supports. They shall be dynamically balanced and discharge air upwards. Condenser-fan motors shall be totally enclosed, thermally protected, and be of a shaft down design to protect from direct contact from harsh environments.

3. Induced-draft blower shall be of the direct driven, single inlet, forward-curved, centrifugal type. It shall be made from aluminized steel with a corrosion-resistant finish and shall be dynamically balanced.

#### **D. Compressor(s)**

1. Fully hermetic, digital scroll type with capacity modulation accomplished by separation of the scroll volutes by pulse width modulation control to provide any capacity between 15 and 100%. Compressor shall have internal high-pressure and temperature protection. Crankcase heaters shall energize on demand.
2. Factory mounted on rubber grommets and internally spring mounted for vibration isolation.
3. Compressor shall be mounted on dedicated mounting plate to ensure secure design and reduced sound levels.
4. Compressor shall be equipped with sound shield to reduce differences in compressor sound between the loaded and unloaded states.

#### **E. Coils**

1. Standard evaporator and condenser coils shall have aluminum lanced plate fins mechanically bonded to seamless internally grooved copper tubes with all joints brazed.
2. Condenser and evaporator coils shall be single slab, single pass design to facilitate easy coil cleaning. Composite coils or coils that require unit top panels removed shall be unacceptable.
3. Coils shall be leak tested at 170 psig and pressure tested at 1875 psig.
4. Optional Coils:
  - a. Optional pre-coated aluminum-fin coils shall have a durable epoxy-phenolic coating to provide protection in mildly corrosive coastal environments. Coating shall be applied to the aluminum fin stock prior to the fin stamping process to create an inert barrier between the aluminum fin and copper tube. Epoxy-phenolic barrier shall minimize galvanic action between dissimilar metals.
  - b. Optional copper-fin coils shall be constructed of copper fins mechanically bonded to copper tubes and copper tube sheets. Galvanized steel tube sheets shall not be acceptable. A polymer strip shall prevent coil assembly from contacting the sheet metal coil pan to minimize potential for galvanic corrosion between coil and pan. All copper construction shall provide protection in moderate coastal environments.
  - c. Optional E-Coated aluminum-fin coils shall have a flexible epoxy polymer coating uniformly applied to all coil surface areas without material bridging between fins. Coating process shall ensure complete coil encapsulation. Color shall be high gloss black with gloss -- 60 deg of 65 to 90% per ASTM D523-89. Uniform dry film thickness from 0.8 to 1.2 mil on all surface areas including fin edges. Superior hardness characteristics of 2H per ASTM D3363-92A and crosshatch adhesion of 4B-5B per ASTM D3359-93. Impact resistance shall be up to 160 in./lb (ASTM D2794-93). Humidity and water immersion resistance shall be up to minimum 1000 and 250 hours respectively (ASTM D2247-92 and ASTM D870-92). Corrosion durability shall be confirmed through testing to be no less than 1000 hours salt spray per ASTM B117-90. Coil construction shall be aluminum fins mechanically bonded to copper tubes. E-Coated aluminum-fin coils shall provide protection in industrial and industrial and coastal combined environments.
  - d. Optional E-Coated copper-fin coils shall have a flexible epoxy polymer coating uniformly applied to all coil surface areas without material bridging between fins. Coating process shall ensure complete coil encapsulation. Color shall be high

gloss black with gloss - 60 deg of 65 to 90% per ASTM D523-89. Uniform dry film thickness from 0.8 to 1.2 mil on all surface areas including fin edges. Superior hardness characteristics of 2H per ASTM D3363-92A and crosshatch adhesion of 4B-5B per ASTM D3359-93. Impact resistance shall be up to 160 in./lb (ASTM D2794-93). Humidity and water immersion resistance shall be up to minimum 1000 and 250 hours respectively (ASTM D2247-92 and ASTM D870-92). Corrosion durability shall be confirmed through testing to be no less than 1000 hours salt spray per ASTM B117-90. Coil construction shall be copper fins mechanically bonded to copper tubes with copper tube sheets. Galvanized steel tube sheets shall not be acceptable. A polymer strip shall prevent coil assembly from contacting sheet metal coil pan to maintain coating integrity and minimize corrosion potential between coil and pan. E-Coated copper-fin coils shall provide protection in severe coastal environments.

#### **F. Heating Section**

1. Induced-draft combustion type with energy saving direct-spark ignition system and redundant main gas valve with 2-stage capability on all 3-phase units.
2. Heat Exchanger:
  - a. The standard aluminized heat exchanger shall be of the tubular-section type constructed of a minimum of 20-gage steel coated with a nominal 1.2 mil aluminum-silicone alloy for corrosion resistance.
  - b. The optional stainless steel heat exchanger shall be of the tubular-section type, constructed of a minimum of 20-gage type 409 stainless steel, including stainless steel tubes, vestibule plate, and collector box.
3. Burners shall be of the in-shot type constructed of aluminum-coated steel.
4. All gas piping shall enter the unit at a single location. Gas entry shall be capable through side or bottom for unit.
5. All factory-installed orifices are for operation up to 2,000 feet of altitude. For altitudes between 2,000 ft and 7,000 ft, a factory certified kit shall be furnished for field installation.
6. The integrated gas controller (IGC) board shall include gas heat operation fault notification using an LED (light-emitting diode).
7. Unit shall be equipped with anti-cycle protection with one short cycle on unit flame rollout switch or 4 continuous short cycles on the high-temperature limit switch. Fault indication shall be made using an LED.
8. The IGC board shall contain algorithms that modify evaporator-fan operation to prevent future cycling on high-temperature limit switch.
9. The LED shall be visible without removal of control box access panel.
10. Gas burner tray, when disconnected, shall easily slide out for maintenance.

#### **G. Refrigerant Components**

Each refrigerant circuit shall include:

1. One balanced port thermostatic expansion valve (TXV) with removable power element.
2. Solid core refrigerant filter driers with pressure ports.
3. Refrigerant pressure gage ports and connections on suction, discharge, and liquid lines.

#### **H. Filter Section**

1. Standard filter section shall consist of factory installed 2-in. thick disposable fiberglass filters and shall be on a dedicated slide out track to easily facilitate access and replacement.
2. Filter section shall use standard size filters and be of common sizes within cabinet sizes.

3. Optional MERV-8 pleated filters of commercially available sizes shall be available.
4. Standard 2-in. filter rack shall be field convertible to 4-in. by removing a spacer.

#### I. Controls and Safeties

1. Unit shall include DDC controls (*ComfortLink*) as a standard feature.
  - a. Scrolling Marquee display.
  - b. CCN (Carrier Comfort Network) capable protocol.
  - c. Unit control with standard suction pressure transducer and condensing temperature thermistor.
  - d. Shall provide a 5F temperature difference between cooling and heating set points to meet ASHRAE 90.1 Energy Standard.
  - e. Shall provide and display a current alarm list and an alarm history list.
  - f. Service run test capability.
  - g. Shall accept input from a CO2 sensor (both indoor and outdoor).
  - h. Configurable alarm light shall be provided which activates when certain types of alarms occur.
  - i. Compressor minimum run time (3 minutes) and minimum off time (5 minutes) are provided.
  - j. Service diagnostic mode.
  - k. Economizer control (optional).
  - l. Adaptive conditioned space control logic that matches the compressor capacity and evaporator air flow to the space cooling requirements.
  - m. Unit shall be complete with self-contained low-voltage control circuit.
  - n. Shall include low ambient head pressure control to allow cooling operation down to 0F ambient.
2. Safeties:
  - a. Unit shall incorporate a solid-state compressor lockout that provides optional reset capability through CCN (Carrier Comfort Network), should any of the following safety devices trip and shut off compressor:
    1. Compressor lockout protection provided for either internal or external overload.
    2. Low-pressure protection.
    3. Freeze protection (evaporator coil).
    4. High-pressure protection (high pressure switch or internal).
    5. Compressor reverse rotation protection.
    6. Loss of charge protection.
  - b. Supply-air sensor shall be located in the unit and detect cooling operation.
  - c. Induced draft heating section shall be provided with the following minimum protections:
    1. High-temperature limit switch.
    2. Induced--draft motor speed sensor.
    3. Flame rollout switch.
    4. Flame proving controls.
    5. Redundant gas valve.
3. Compressor Control:  
Compressor shall be controlled by a Pulse width modulated control scheme that operates an unloading solenoid valve connected to the digital scroll compressor. The pressure differential across a pressure actuator inside the compressor lifts the upper scroll away from the lower scroll and provides the compressor unloading.

#### J. Operating Characteristics

1. Unit shall be capable of starting and running at 125F ambient outdoor temperature per maximum load criteria of ARI Standard 210.
2. Unit shall be capable of operating in cooling mode down to an outdoor ambient temperature of 0F.

3. Unit shall be provided with fan time delay to prevent cold air delivery in heating mode.

#### K. Electrical Requirements

All unit power wiring shall enter unit cabinet at a single location through the unit side or bottom.

#### L. Motors

1. Compressor motors shall be cooled by refrigerant gas passing through motor windings and shall have line break thermal and current overload protection.
2. Evaporator fan motor shall have permanently lubricated, sealed bearings and inherent automatic-reset thermal overload protection. Evaporator motors are designed specifically for Carrier and do not have conventional horsepower (hp) ratings listed on the motor nameplate. Motors are designed and qualified in the "air-over" location downstream of the cooling coil and carry a maximum continuous bhp rating that is the maximum application bhp rating for the motor; no "safety factors" above that rating may be applied. Evaporator fan motors shall be designed for use with variable speed AC drive controller.
3. Totally enclosed condenser-fan motor shall have permanently lubricated, sealed bearings, and inherent automatic-reset thermal overload protection.
4. Induced-draft motor shall have permanently lubricated sealed bearings and inherent automatic-reset thermal overload protection.

#### M. Special Features

Certain features are not applicable when the features designated \* are specified. For assistance in amending the specifications, contact your local Carrier Sales Office.

1. \* Full Perimeter Roof Curbs (Horizontal and Vertical Supply and/or Return Duct Applications):
  - a. Formed of 16-gage galvanized steel with wood nailer strip and shall be capable of supporting entire unit weight. Roof curb corners shall be interlocking design.
  - b. Permits installing and securing ductwork to curb prior to mounting unit on the curb. Field assembly required.
  - c. Shall be available in both 14-in. and 24-in. height.
2. \* Adapter Roof Curb:  
Shall be available for fit up to previously installed Carrier DJ, TJ, LJ, TF, HJ, TM roof curb (03-07 sizes).
3. \* Integrated Economizer:
  - a. Tilt-out economizer shall be furnished and installed complete with outside air dampers and controls.
  - b. Low-leakage (less than 2%), opposing, gear-driven dampers with UL approved gears.
  - c. Capable of introducing up to 100% outdoor air for minimum ventilation as well as free cooling.
  - d. Damper actuator shall be fully modulating design with electronic control via 4-20 mA signal from *ComfortLink* controller
  - e. Economizer outdoor hood shall be pre-painted and fully assembled.
  - f. Economizer shall be available for field or factory installation.
4. \* Two-Position Motorized Outdoor Air Damper:
  - a. The damper shall admit up to 50% outdoor air. Spring return damper closes when unit is off.
  - b. The package shall include a multiple--blade damper and motors.
  - c. Shall be available as factory--installed option and field--installed accessory.

5. \* Manual Outdoor Air Damper:
  - a. The damper shall admit up to 33% outdoor air.
  - b. Shall include hood, damper plate, and screen.
  - c. Shall be available as factory--installed option and field--installed accessory.
6. \* Barometric Relief Damper Package:
  - a. Package shall include damper, seals, hardware, and hoods to relieve excess internal pressure.
  - b. Integrated barometric relief capabilities on economizer shall be available.
  - c. Damper shall close due to gravity upon unit shutdown.
7. \* Power Exhaust:
  - a. Shall include two (2) propeller exhaust fans, 0.25 Hp 208/230 v, 460 v direct-drive motor on each, and damper for units with economizer to control over-pressurization of building. Single-stage control.
  - b. Power exhaust shall fit on both vertical and horizontal configured unit.
  - c. Shall be available as factory--installed option and field--installed accessory.
8. Single Enthalpy Sensor:
 

The enthalpy sensor shall provide economizer control based on outdoor air enthalpy. The economizer control shall include logic to calculate the wet bulb and dry bulb temperatures of the outdoor air.
9. Differential Enthalpy Sensor:
  - a. For use with economizer only.
  - b. Capable of comparing heat content (temperature and humidity) of outdoor air and indoor air and controlling economizer cut-in point at the most economical level.
10. Convenience Outlet:
  - a. Optional factory--installed powered convenience outlet shall be internally mounted with an externally accessible 115--v, 2--plug female receptacle with hinged cover. Shall include 15 amp GFI with independent fuse protection and service receptacle disconnect. The convenience outlet is powered from the unit main power wiring through a factory-installed step down transformer. The power wiring for the transformer needs to be field connected per local codes. This may mean wiring before the disconnect switch or after.
  - b. Optional factory-installed non-powered convenience outlet shall be internally mounted with an externally accessible 115-v, 2-plug female receptacles with hinged cover. There is no step down transformer installed from the factory.
11. \* Non-Fused Disconnect Switch:
 

Shall be factory-installed, internally mounted, NEC and UL approved. Non-fused switch shall provide unit power shutoff. Shall be accessible from outside the unit and shall provide power off lockout capability.
12. \* Unit Circuit Breaker:
 

Shall be factory-installed, internally mounted, NEC and UL approved. Breaker shall provide unit power shutoff. Shall be accessible from outside the unit and shall provide power off lockout capability.
13. CO2 Sensor:
 

The duct--mounted or wall-mounted CO2 sensor shall have the ability to monitor CO2 levels and relay information to the controller. The controller will use CO2 level information to modulate the economizer and provide demand control ventilation. The sensor shall be available as field or factory-installed.
14. Return Air/Supply Air Smoke Detector:
 

The smoke detector shall send input to the controller to shut down the unit in case smoke is detected. The smoke detector shall be factory installed in the return air section or shall be available as a field-installed accessory.
15. Filter Status:
 

The filter status switch shall be a pressure switch and will indicate a dirty filter. The switch shall be available as field or factory-installed.
16. Fan Status:
 

The fan status switch shall be a pressure switch and will indicate indoor fan operation. The switch shall be available as field or factory installed.
17. \* MERV-8 Pleated Return Air Filters:
 

The filters shall be MERV--8 efficient. The filters shall be 2-in., pleated filters.
18. \* Four-inch Return Air Filter Capability:
 

The unit shall be capable of accepting field supplied 4--in. filters by removing a spacer rack.
19. \* Low Range Fan Performance Motor/Drive:
 

This motor/drive option shall provide low range motor and drive capability to enhance evaporator fan performance.
20. \* High Fan Performance Motor/Drive:
 

This motor/drive offering shall provide high range motor and drive capability to enhance evaporator fan performance.
21. Hail Guard, Condenser Coil Grille:
 

Shall protect the condenser coil from hail, flying debris, and damage by large objects without increasing unit clearances.
25. Phase Loss Protection:
 

Shall provide unit shutdown when an electrical phase loss is detected. Shall be automatic reset type.
26. Roof Curb Burglar Bar:
 

Shall be 1/2-in diameter rod with 9-in. on center design grid pattern. Shall mount in roof curb openings.
27. \* Space Temperature Sensor:
 

Shall provide means to sense the space temperature from and adjust the evaporator fan airflow to satisfy the space temperature to set point.

## GUIDE SPECIFICATIONS

### 50PD Packaged Rooftop Electric Cooling Unit with Optional Electric Heat Variable Capacity, Variable Air Volume Cooling Constant Air Volume Heating with Puron R-R410A Refrigerant and COMFORTLink™ Controls

#### Cooling Size Range:

4 to 5 Tons, Nominal Cooling  
48,000 to 60,000 BTUH

#### Heating Size Range:

5 to 25 kW Nominal (Electric Heating)

#### Carrier Model Numbers: 50PD

## Part 1 — General

### 1.01 SYSTEM DESCRIPTION

Outdoor only, rooftop mounted, electrically controlled heating and cooling unit utilizing fully hermetic digital scroll compressors with on demand crankcase heaters for cooling duty and optional electric resistance heaters for heating duty. Supply air shall be discharged downward or horizontally, as shown on contract drawings. Supply air fan shall deliver the correct quantity and temperature of air to meet the space cooling and heating demand. Controls shall adjust supply air quantity and temperature to adapt to conditioned space load demand. Units shall be of ultra high cooling efficiency and utilize environmentally friendly Puron (R-410A) refrigerant.

### 1.02 QUALITY ASSURANCE

- A. Unit shall well exceed ASHRAE 90.1-2004 and ENERGY STAR efficiency standards. SEER shall be as high as 15.
- B. Unit shall be rated in accordance with ARI Standards 210.
- C. Units shall be designed in accordance with UL Standard 1995. Unit shall be UL and UL Canada, tested as a total package
- D. Unit shall be rated in accordance with ARI sound standards 270.
- E. Unit shall be designed to conform to ASHRAE 15.
- F. Roof curb shall be designed to conform to NRCA Standards.
- G. Insulation and adhesive shall meet NFPA 90A requirements for flame spread and smoke generation.
- H. Unit casing shall be capable of withstanding 500-hour salt spray exposure per ASTM B117 (scribed specimen).
- I. Unit shall be manufactured in a facility registered to ISO 9001:2000.
- J. Each unit shall be subjected to a completely automated run testing on the assembly line.

### 1.03 DELIVERY, STORAGE, AND HANDLING

Unit shall be stored and handled per manufacturer's recommendations.

## Part 2 — Products

### 2.01 EQUIPMENT (STANDARD)

#### A. General

The 50PG unit shall be a fully factory assembled, pre-tested, single-piece heating and cooling unit. Contained within the unit enclosure shall be all factory wiring, piping, controls, Puron refrigerant charge (R-410A), and special features required prior to field start-up.

#### B. Unit Cabinet

1. Constructed of galvanized steel, bonderized and coated with a pre-painted baked enamel finish on all externally exposed surfaces. Internal surfaces shall be of a primer coated finish.
2. All air stream interior surfaces shall be insulated with a minimum 1/2-in. thick, 1 lb density foil faced cleanable insulation. Insulation shall be bonded with a thermosetting resin (8 to 12% by weight nominal, phenol formaldehyde typical), and coated with an acrylic or other material that meets the NFPA 90 flame retardance requirements and has an "R" value of 3.70. Insulation

shall also be encapsulated with panel design or tape edges ensuring secure fit.

3. Cabinet panels shall be hinged with integrated non-corrosive hinges. Large area hinged access panels for the filter, compressors, evaporator fan, and control box and heat section areas. Each panel shall use multiple quarter-turn latches and handles. Each major external hinged access panel shall be double-wall construction and permanently attached to the rooftop unit. Panels shall also include tiebacks.
4. Return air filters shall be accessible through a dedicated hinged access panel and be on a slide-out track using standard size filters. Filter shall be standard off the shelf sizes and be the size per cabinet. Capability for 2 or 4 inch filters shall be on all sizes.
5. Holes shall be provided in the base rails (minimum 16 gauge) for rigging shackles and level travel and movement during overhead rigging operations.
6. Fork lift slots shall be available from three sides of the unit (end and 2 sides).
7. Unit shall have a factory installed internally sloped condensate drain pan, providing a minimum 3/4-in.—14 NPT connection to prevent standing water from accumulating. Pan shall be fabricated of high impact polycarbonate material and shall slide out for cleaning and or maintenance. An alternate vertical drain (3/4-in. NPT) connection shall also be available. All drain pans conform to ASHRAE 62 self—draining provisions.
8. Unit shall have standard thru-the-bottom power and control wiring connection capability.

#### C. Fans

1. Indoor blower (evaporator fan):
  - a. Centrifugal supply air blower shall have rubber--isolated, cartridge type ball bearings and adjustable belt drive.
  - b. Fan wheel shall be made from steel with a corrosion resistant finish. It shall be a dynamically balanced, double-inlet type with forward-curved blades.
  - c. The indoor fan system (blower wheels, motors, belts, and both bearings) shall slide out for easy access.
  - d. Evaporator-fan motors shall be continuous operation, open drip--proof. Bearings shall be sealed, permanently lubricated ball bearing type for longer life and lower maintenance.
  - e. Fan belt shall be located on opposite side of evaporator coil to prevent damage from broken fan belts.
  - f. Evaporator fan motor Adjustable Speed AC drive – shall follow the provisions of UL 508C, shall have casing material rated for plenum use, shall control the motor from 20% to 100% of the 60Hz speed with input signal derived from the space temperature. AC drive shall have a display for setting drive parameters that can be mounted remote from the AC drive.
2. Condenser fans shall be of the direct-driven propeller type, with corrosion-resistant aluminum blades riveted to corrosion-resistant steel supports. They shall be dynamically balanced and discharge air upwards. Condenser-fan motors shall be totally enclosed,

thermally protected, and be of a shaft down design to protect from direct contact from harsh environments.

3. Induced-draft blower shall be of the direct driven, single inlet, forward-curved, centrifugal type. It shall be made from aluminized steel with a corrosion-resistant finish and shall be dynamically balanced.

#### **D. Compressor(s)**

1. Fully hermetic, digital scroll type with capacity modulation accomplished by separation of the scroll volutes by pulse width modulation control to provide any capacity between 15 and 100%. Compressor shall have internal high-pressure and temperature protection. Crankcase heaters shall energize on demand.
2. Factory mounted on rubber grommets and internally spring mounted for vibration isolation.
3. Compressor shall be mounted on dedicated mounting plate to ensure secure design and reduced sound levels.
4. Compressor shall be equipped with sound shield to reduce differences in compressor sound between the loaded and unloaded states.

#### **E. Coils**

1. Standard evaporator and condenser coils shall have aluminum lanced plate fins mechanically bonded to seamless internally grooved copper tubes with all joints brazed.
2. Condenser and evaporator coils shall be single slab, single pass design to facilitate easy coil cleaning. Composite coils or coils that require unit top panels removed shall be unacceptable.
3. Coils shall be leak tested at 170 psig and pressure tested at 1875 psig.
4. Optional Coils:
  - a. Optional pre-coated aluminum-fin coils shall have a durable epoxy-phenolic coating to provide protection in mildly corrosive coastal environments. Coating shall be applied to the aluminum fin stock prior to the fin stamping process to create an inert barrier between the aluminum fin and copper tube. Epoxy-phenolic barrier shall minimize galvanic action between dissimilar metals.
  - b. Optional copper--fin coils shall be constructed of copper fins mechanically bonded to copper tubes and copper tube sheets. Galvanized steel tube sheets shall not be acceptable. A polymer strip shall prevent coil assembly from contacting the sheet metal coil pan to minimize potential for galvanic corrosion between coil and pan. All copper construction shall provide protection in moderate coastal environments.
  - c. Optional E--Coated aluminum--fin coils shall have a flexible epoxy polymer coating uniformly applied to all coil surface areas without material bridging between fins. Coating process shall ensure complete coil encapsulation. Color shall be high gloss black with gloss -- 60 deg of 65 to 90% per ASTM D523-89. Uniform dry film thickness from 0.8 to 1.2 mil on all surface areas including fin edges. Superior hardness characteristics of 2H per ASTM D3363-92A and crosshatch adhesion of 4B-5B per ASTM D3359-93. Impact resistance shall be up to 160 in./lb (ASTM D2794-93). Humidity and water immersion resistance shall be up to minimum 1000 and 250 hours respectively (ASTM D2247-92 and ASTM D870-92). Corrosion durability shall be confirmed through testing to be no less than 1000 hours salt spray per ASTM B117-90. Coil construction shall be aluminum fins mechanically bonded to copper tubes. E-Coated aluminum-fin coils shall provide protection in industrial and industrial and coastal combined environments.
  - d. Optional E--Coated copper--fin coils shall have a flexible epoxy polymer coating uniformly applied to all coil surface

areas without material bridging between fins. Coating process shall ensure complete coil encapsulation. Color shall be high gloss black with gloss - 60 deg of 65 to 90% per ASTM D523-89. Uniform dry film thickness from 0.8 to 1.2 mil on all surface areas including fin edges. Superior hardness characteristics of 2H per ASTM D3363-92A and crosshatch adhesion of 4B-5B per ASTM D3359-93. Impact resistance shall be up to 160 in./lb (ASTM D2794-93). Humidity and water immersion resistance shall be up to minimum 1000 and 250 hours respectively (ASTM D2247-92 and ASTM D870-92). Corrosion durability shall be confirmed through testing to be no less than 1000 hours salt spray per ASTM B117-90. Coil construction shall be copper fins mechanically bonded to copper tubes with copper tube sheets. Galvanized steel tube sheets shall not be acceptable. A polymer strip shall prevent coil assembly from contacting sheet metal coil pan to maintain coating integrity and minimize corrosion potential between coil and pan. E--Coated copper--fin coils shall provide protection in severe coastal environments.

#### **F. Heating Section**

1. Heater element open coil resistance wire, nickel-chrome alloy, 0.29 inches inside diameter, strung through ceramic insulators mounted on metal frame. Coil ends are staked and welded to terminal screw slots.
2. Heater assemblies are provided with integral fusing for protection of internal heater circuits not exceeding 48 amps each.
3. Auto reset thermo limit controls, magnetic heater contactors (24 v coil) and terminal block all mounted in electric heater control box (minimum 18 gauge galvanized steel) attached to end of heater assembly.

#### **G. Refrigerant Components**

Each refrigerant circuit shall include:

1. One balanced port thermostatic expansion valve (TXV) with removable power element.
2. Solid core refrigerant filter driers with pressure ports.
3. Refrigerant pressure gage ports and connections on suction, discharge, and liquid lines.

#### **H. Filter Section**

1. Standard filter section shall consist of factory installed 2-in. thick disposable fiberglass filters and shall be on a dedicated slide out track to easily facilitate access and replacement.
2. Filter section shall use standard size filters and be of common sizes within cabinet sizes.
3. Optional MERV-8 pleated filters of commercially available sizes shall be available.
4. Standard 2-in. filter rack shall be field convertible to 4-in. by removing a spacer rack.

#### **I. Controls and Safeties**

1. Unit shall include DDC controls (*ComfortLink*) as a standard feature.
  - a. Scrolling Marquee display.
  - b. CCN (Carrier Comfort Network) protocol capable.
  - c. Unit control with standard suction pressure transducer and condensing temperature thermistor.
  - d. Shall provide a 5F temperature difference between cooling and heating set points to meet ASHRAE 90.1 Energy Standard.
  - e. Shall provide and display a current alarm list and an alarm history list.
  - f. Service run test capability.
  - g. Shall accept input from a CO2 sensor (both indoor and outdoor).

- h. Configurable alarm light shall be provided which activates when certain types of alarms occur.
- i. Compressor minimum run time (3 minutes) and minimum off time (5 minutes) are provided.
- j. Service diagnostic mode.
- k. Economizer control (optional).
- l. Adaptive conditioned space control logic that matches the compressor capacity and evaporator air flow to the space cooling requirements.
- m. Unit shall be complete with self-contained low-voltage control circuit.
- n. Shall include low ambient head pressure control to allow cooling operation down to 0F ambient.

**2. Safeties:**

- a. Unit shall incorporate a solid--state compressor lockout that provides optional reset capability through CCN (Carrier Comfort Network), should any of the following safety devices trip and shut off compressor:
  - 1. Compressor lockout protection provided for either internal or external overload.
  - 2. Low-pressure protection.
  - 3. Freeze protection (evaporator coil).
  - 4. High-pressure protection (high pressure switch or internal).
  - 5. Compressor reverse rotation protection.
  - 6. Loss of charge protection.
- b. Supply-air sensor shall be located in the unit and detect cooling operation.
- c. Induced draft heating section shall be provided with the following minimum protections:
  - 1. High-temperature limit switch.
  - 2. Induced-draft motor speed sensor.
  - 3. Flame rollout switch.
  - 4. Flame proving controls.
  - 5. Redundant gas valve.

**3. Compressor Control:**

Compressor shall be controlled by a Pulse width modulated control scheme that operates an unloading solenoid valve connected to the digital scroll compressor. The pressure differential across a pressure actuator inside the compressor lifts the upper scroll away from the lower scroll and provides the compressor unloading.

**J. Operating Characteristics**

- 1. Unit shall be capable of starting and running at 125F ambient outdoor temperature per maximum load criteria of ARI Standard 210.
- 2. Unit shall be capable of operating in cooling mode down to an outdoor ambient temperature of 0F.
- 3. Unit shall be provided with fan time delay to prevent cold air delivery in heating mode.

**K. Electrical Requirements**

All unit power wiring shall enter unit cabinet at a single location through the unit side or bottom.

**L. Motors**

- 1. Compressor motors shall be cooled by refrigerant gas passing through motor windings and shall have line break thermal and current overload protection.
- 2. Evaporator fan motor shall have permanently lubricated, sealed bearings and inherent automatic-reset thermal overload protection. Evaporator motors are designed specifically for Carrier and do not have conventional horsepower (hp) ratings listed on the motor nameplate. Motors are designed and qualified in the "air-over" location downstream of the cooling coil and carry a maximum continuous bhp rating that is the maximum application bhp rating for the motor; no "safety factors" above

that rating may be applied. Evaporator fan motors shall be designed for use with variable speed AC drive controller.

- 3. Totally enclosed condenser--fan motor shall have permanently lubricated, sealed bearings, and inherent automatic-reset thermal overload protection.
- 4. Induced--draft motor shall have permanently lubricated sealed bearings and inherent automatic-reset thermal overload protection.

**M. Special Features**

Certain features are not applicable when the features designated \* are specified. For assistance in amending the specifications, contact your local Carrier Sales Office.

- 1. \* Full Perimeter Roof Curbs (Horizontal and Vertical Supply and/or Return Duct Applications):
  - a. Formed of 16-gage galvanized steel with wood nailer strip and shall be capable of supporting entire unit weight. Roof curb corners shall be interlocking design.
  - b. Permits installing and securing ductwork to curb prior to mounting unit on the curb. Field assembly required.
  - c. Shall be available in both 14--in. and 24--in. height.
- 2. \* Adapter Roof Curb:
  - Shall be available for fit up to previously installed Carrier DJ, TJ, LJ, TF, HJ, TM roof curb (03--07 sizes).
- 3. \* Integrated Economizer:
  - a. Tilt-out economizer shall be furnished and installed complete with outside air dampers and controls.
  - b. Low--leakage (less than 2%), opposing, gear-driven dampers with UL approved gears.
  - c. Capable of introducing up to 100% outdoor air for minimum ventilation as well as free cooling.
  - d. Damper actuator shall be fully modulating design with electronic control via 4-20 mA signal from *ComfortLink* controller
  - e. Economizer outdoor hood shall be pre-painted and fully assembled. Economizer outdoor hood requires field assemble on other sizes.
  - f. Economizer shall be available for both field or factory installation.
- 4. \* Two-Position Motorized Outdoor Air Damper:
  - a. The damper shall admit up to 50% outdoor air. Spring return damper closes when unit is off.
  - b. The package shall include a multiple--blade damper and motors.
  - c. Shall be available as factory--installed option and field--installed accessory.
- 5. \* Manual Outdoor Air Damper:
  - a. The damper shall admit up to 33% outdoor air.
  - b. Shall include hood, damper plate, and screen.
  - c. Shall be available as factory--installed option and field--installed accessory.
- 6. \* Barometric Relief Damper Package:
  - a. Package shall include damper, seals, hardware, and hoods to relieve excess internal pressure.
  - b. Integrated barometric relief capabilities on economizer shall be available.
  - c. Damper shall close due to gravity upon unit shutdown.
- 7. \* Power Exhaust:
  - a. Shall include two (2) propeller exhaust fans, 0.25 Hp 208/230v, 460v direct-drive motor on each, and damper for units with economizer to control over-pressurization of building. Single--stage control.
  - b. Power exhaust shall fit on both vertical and horizontal configured unit.
  - c. Shall be available as factory-installed option and field-installed accessory.

8. Single Enthalpy Sensor:  
The enthalpy sensor shall provide economizer control based on outdoor air enthalpy. The economizer control shall include logic to calculate the wet bulb and dry bulb temperatures of the outdoor air.
9. Differential Enthalpy Sensor:
  - a. For use with economizer only.
  - b. Capable of comparing heat content (temperature and humidity) of outdoor air and indoor air and controlling economizer cut-in point at the most economical level.
10. Convenience Outlet:
  - a. Optional factory--installed powered convenience outlet shall be internally mounted with an externally accessible 115--v, 2--plug female receptacle with hinged cover. Shall include 15 amp GFI with independent fuse protection and service receptacle disconnect. The convenience outlet is powered from the unit main power wiring through a factory-installed step down transformer. The power wiring for the transformer needs to be field connected per local codes. This may mean wiring before the disconnect switch or after.
  - b. Optional factory-installed non-powered convenience outlet shall be internally mounted with an externally accessible 115-v, 2-plug female receptacles with hinged cover. There is no step down transformer installed from the factory.
11. \* Non--Fused Disconnect Switch:  
Shall be factory-installed, internally mounted, NEC and UL approved. Non-fused switch shall provide unit power shutoff. Shall be accessible from outside the unit and shall provide power off lockout capability.
12. \* Unit Circuit Breaker:  
Shall be factory-installed, internally mounted, NEC and UL approved. Breaker shall provide unit power shutoff. Shall be accessible from outside the unit and shall provide power off lockout capability.
13. CO2 Sensor:  
The duct--mounted or wall-mounted CO2 sensor shall have the ability to monitor CO2 levels and relay information to the controller. The controller will use CO2 level information to modulate the economizer and provide demand control ventilation. The sensor shall be available as field or factory-installed.
14. Return Air/Supply Air Smoke Detector:  
The smoke detector shall send input to the controller to shut down the unit in case smoke is detected. The smoke detector shall be factory installed in the return air section or shall be available as a field-installed accessory.
15. Filter Status:  
The filter status switch shall be a pressure switch and will indicate a dirty filter. The switch shall be available as field or factory-installed.
16. Fan Status:  
The fan status switch shall be a pressure switch and will indicate indoor fan operation. The switch shall be available as field or factory installed.
17. \* MERV-8 Pleated Return Air Filters:  
The filters shall be MERV--8 efficient. The filters shall be 2-in., pleated filters.
18. \* Four-inch Return Air Filter Capability:  
The unit shall be capable of accepting field supplied 4--in. filters by removing a spacer rack.
19. \* Low Range Fan Performance Motor/Drive:  
This motor/drive option shall provide low range motor and drive capability to enhance evaporator fan performance.
20. \* High Fan Performance Motor/Drive:  
This motor/drive offering shall provide high range motor and drive capability to enhance evaporator fan performance.
21. Hail Guard, Condenser Coil Grille:  
Shall protect the condenser coil from hail, flying debris, and damage by large objects without increasing unit clearances.
25. Phase Loss Protection:  
Shall provide unit shutdown when an electrical phase loss is detected. Shall be automatic reset type.
26. Roof Curb Burglar Bar:  
Shall be 1/2--in diameter rod with 9--in. on center design grid pattern. Shall mount in roof curb openings.
27. \* Space Temperature Sensor T55, T56 or T58:  
Shall provide means to sense the space temperature from T55, T56 or T58 Sensor and adjust the evaporator fan airflow to satisfy the space temperature to set point.
28. \* Electric Resistance Heater Package
  - a. Fully assembled for installation. The packages are designed in accordance with UL safety standards 1995 and listed by ETL. Heater construction approved by UL 5306.
  - b. Single point electrical connection kits available for each heater when required.