

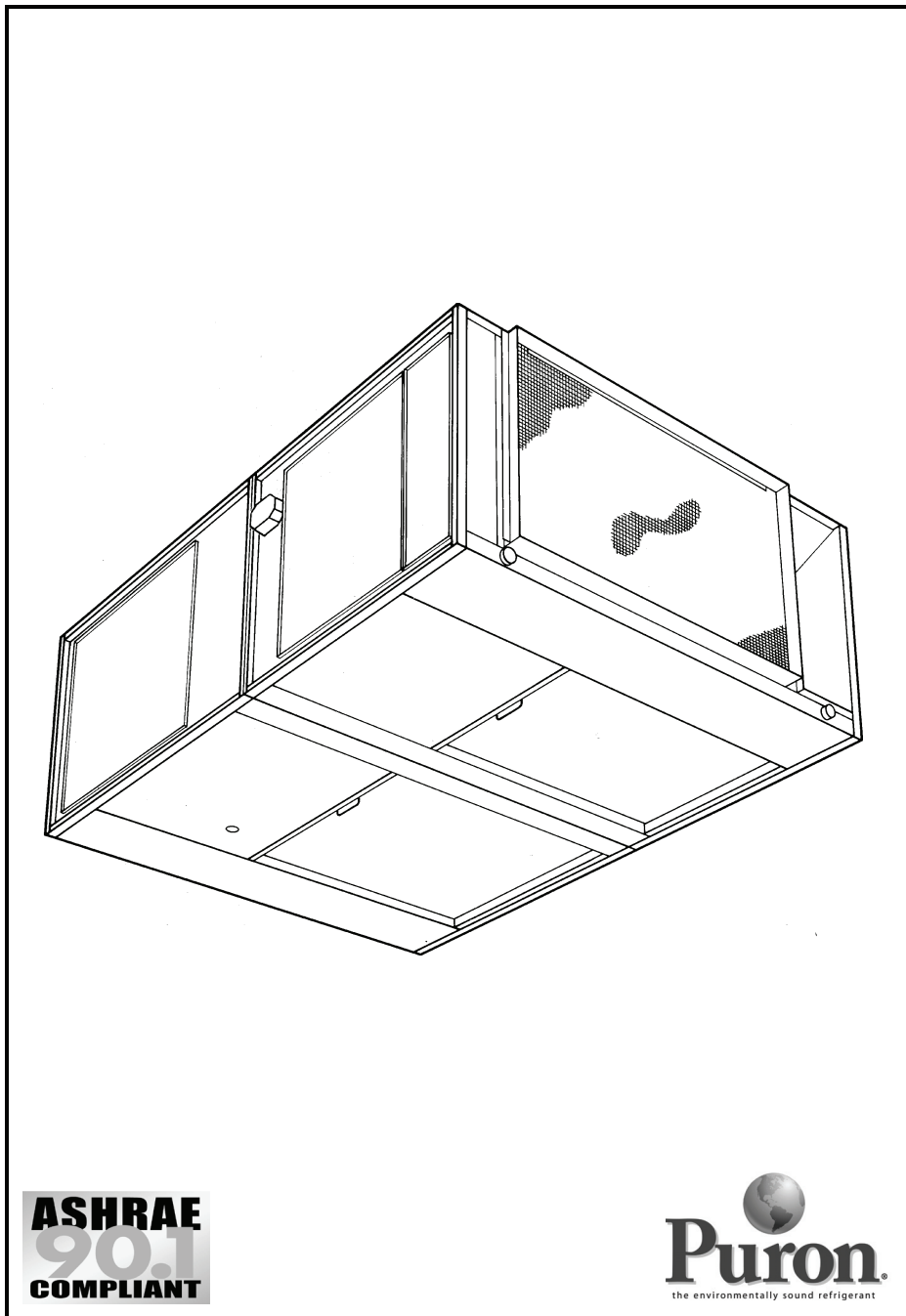

Product Data

ROOMTOP® 50AH024-096 Horizontal Indoor Single-Package Cooling Units with PURON® Refrigerant (R-410A)

2 to 8 Nominal Tons



The 50AH single-package cooling units feature:

- ASHRAE 90.1 certification
- scroll compressor technology
- compact and flexible design
- Puron refrigerant (R-410A)
- easy maintenance
- high quality and reliability
- quiet and efficient scroll compressor technology
- water or air-cooled units availability
- belt-drive motors

Features/Benefits

All in one package — high cooling efficiency, installation convenience, ease of accessibility allow for time-saving maintenance.

Space and cost saving design

The Roomtop 50AH unit is specifically designed to provide building owners with a versatile horizontal air conditioning system that can be adapted to many cooling applications. The flexible design and low silhouette enable it to fit easily and securely within the ceiling above the conditioned space. Single-package construction makes it easy to install with minimal time and cost.

**ASHRAE
90.1
COMPLIANT**

Puron
the environmentally sound refrigerant

Features/Benefits (cont)



Application flexibility

If desired for particular applications, the unit can also be installed as a package or split system with the condenser section mounted horizontally. Centrifugal fans permit ducting of both evaporator and condenser air.

Quiet operation

Commercial end users appreciate the extra comfort of quiet operation. Carrier engineers met the challenge by specifying heavy insulation, vibration-resistant construction and operating components that function at low noise levels, all of which keep system sound at a minimum level.

Easy maintenance

When it comes to maintenance, the 50AH unit rates high in accessibility. Indoor location is ideal for the maintenance technician, and side access panels, easily removed, provide quick and convenient access to all components when needed. As an added plus, all required service/maintenance access can be from one side, allowing the unit to be located against a wall or ceiling

plenum obstruction, an obvious space-saving idea.

Carrier quality and reliability

The Roomtop® 50AH units have much to offer the commercial owner. Every unit is thoroughly run tested at the factory and equipped with safety controls designed to monitor and protect over the life of the unit.

Scroll compressor technology

Scroll compressors are designed for high efficiency and are internally spring mounted to minimize vibration noise. Each compressor is hermetically sealed against contamination to promote longer life and dependable operation. Scroll compressors are standard on all units.

Puron® refrigerant

Carrier's 50AH units are available with Puron refrigerant. Puron refrigerant (R-410A) is a non-chlorine based refrigerant.

Puron refrigerant characteristics, compared to R-22, have:

- Binary and near azeotropic mixture of 50% R-32 and 50% R-125.

- Higher efficiencies (50 to 60% higher operating pressures).
- Non-ozone depleting potential and low global warming potential.
- Virtually no glide. Unlike other alternative refrigerants, the two components in Puron refrigerant have virtually the same leak rates. Therefore, refrigerant can be added if necessary without recovering the charge.

Safety features and easy servicing

Each compressor has its own independent refrigerant circuit and is protected by individual branch fusing. Additional protection is provided by thermal overloads and high and low pressure safety switches.

- High and low pressure switches on each circuit.
- Thermostatic expansion valves (TXV) on each circuit mounted outside the airstream.
- Stainless steel or insulated galvanized condensate pan.
- Single point electrical connections and piping connections.

Table of contents

	Page
Features/Benefits	1,2
Model Number Nomenclature	3
ARI Capacity Ratings	3
Physical Data	4,5
Options and Accessories	6
Dimensions	7-10
Selection Procedure	11
Performance Data	12-15
Controls	15
Electrical Data	16
Typical Wiring Schematic	17,18
Typical Piping and Wiring	19
Application Data	20,21
Guide Specifications	22,23

Model number nomenclature

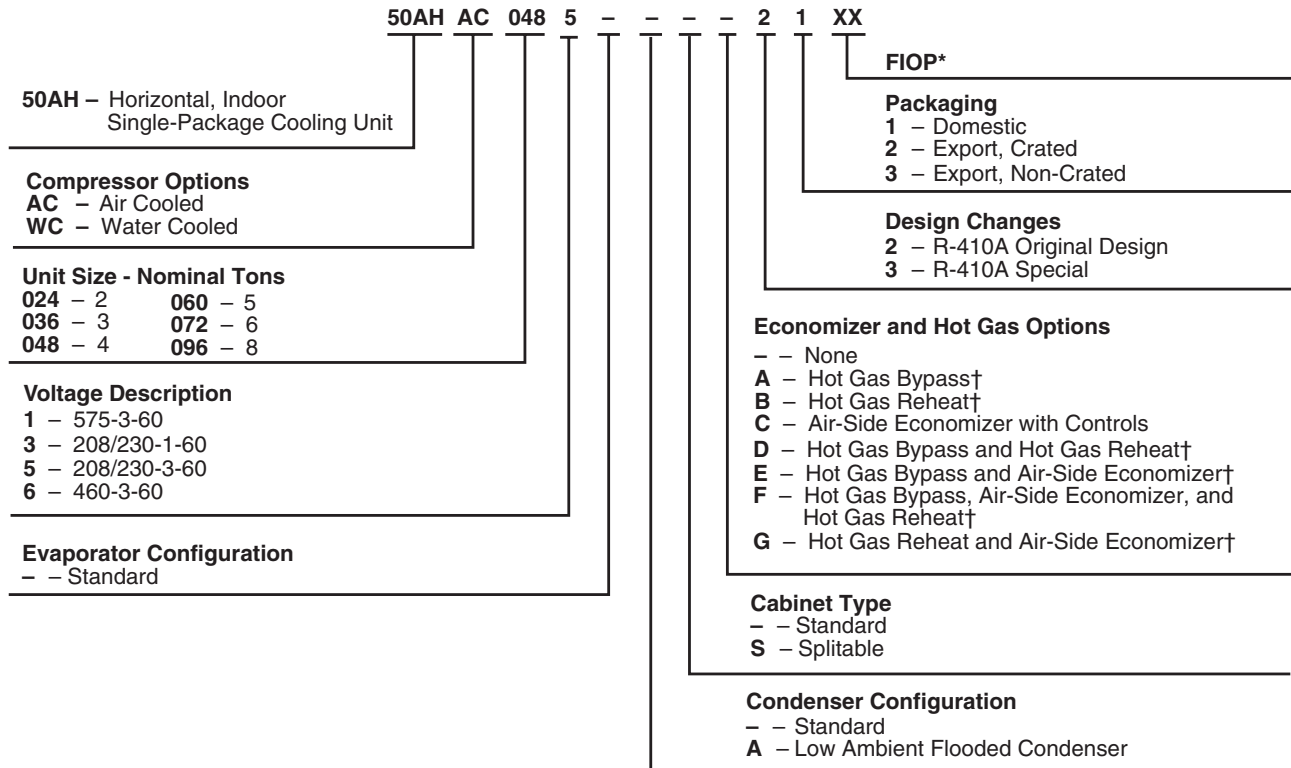

* Factory-installed option, contact your Carrier representative for details.
 †Not available with splitable units.

Quality Assurance

Certified to ISO 9001:2000

ARI* capacity ratings

UNIT 50AH	V-PH-Hz	TOTAL kW	NET TOTAL COOLING CAP. (Btuh)	NOMINAL CFM	EER	SEER
024	208-1-60	1.6	27,370	800	—	15.4
036	208/230-1-60	2.5	39,230	1200	—	13.8
	208/230-3-60				—	14.0
	460-3-60				—	14.0
048	208/230-1-60	3.1	49,120	1600	—	13.8
	208/230-3-60				—	14.1
	460-3-60				—	14.1
060	208/230-1-60	4.2	62,120	2000	—	13.0
	208/230-3-60				—	13.0
	460-3-60				—	13.0
072	208/230-1-60	6.3	77,020	2400	12.2	—
	208/230-3-60				12.2	—
	460-3-60				12.2	—
096	208/230-1-60	8.1	90,590	3200	11.2	—
	208/230-3-60				11.2	—
	460-3-60				11.2	—

LEGEND

dB — Decibels
EER — Energy Efficiency Ratio

*Air Conditioning and Refrigeration Institute.

NOTES:

1. Ratings are at zero condenser air static and rated in accordance with ARI Standard 210/240 (size 024-060 units) or 340/360 (size 072 and 096 units).

2. $EER = \frac{NET\ CAPACITY\ (Btuh)}{TOTAL\ WATTS}$



Physical data



UNIT 50AH	024	036	048
OPERATING WEIGHT (lb)			
Base Unit	903	910	952
Evaporator/Condenser Sections	399/484	401/489	417/515
SHIPPING WEIGHT (lb)*	1036	1043	1085
REFRIGERANT TYPE		R-410A	
Operating Charge (lb-oz)†	4-5	4-5	8-8
COMPRESSOR — TYPE		Scroll	
Quantity...Model	1...ZP20K5E	1...ZP31K5E	1...ZP38K5E
Oil (oz)	25	25	42
HPS Setting (psig)		650 ± 7	
Cutout		Manual Reset	
Reset			
LPS Setting (psig)		75 ± 7	
Cutout		100 ± 7	
Reset			
CONDENSATE DRAIN CONNECTION		7/8...OD	
Size (in.)...Type			
CONDENSER COIL		Copper Tubes — Aluminum Fins	
Size (L x H) (in.)	40 x 30	40 x 30	90 x 30
Number of Rows...Fins/in.	4...14	4...14	2...12
CONDENSER FAN		Centrifugal — Belt Drive	
Nominal Cfm	1700	2000	2500
Blower Size (in.)	15 x 15	15 x 15	15 x 15
Motor Hp	0.33	0.33	0.33
Motor Rpm	1750	1750	1750
EVAPORATOR COIL		Copper Tubes — Aluminum Fins	
Size (L x H) (in.)	32 x 16	32 x 16	32 x 26
Number of Rows...Fins/in.	3...12	3...12	3...14
EVAPORATOR AIR FAN		Centrifugal — Belt Drive	
Nominal Cfm	800	1200	1600
Blower Size (in.)	12 x 9	12 x 9	12 x 9
Motor Hp (Rpm)	0.25 (1750)	0.33 (1750)	0.33 (1750)
INDOOR-AIR FILTERS		Factory-Supplied Cleanable Type	
Number...Size (in.)	2...18 x 24 x 1	2...18 x 24 x 1	2...18 x 24 x 1
INTERCONNECTING TUBING SIZE			
Suction (Qty...in.)	1...5/8	1...5/8	1...7/8
Liquid (Qty...in.)	1...3/8	1...3/8	1...3/8
WATER CONNECTIONS			
Pipe Size (OD) (in.)	7/8	7/8	1 1/8

LEGEND

HPS — High-Pressure Switch
LPS — Low-Pressure Switch

*Shipping weights include base unit plus packaging.
 †If components are to be split, additional refrigerant will be needed.

NOTE: If components are to be split, the maximum length of refrigerant tubing to be used is 50 equivalent ft, assuming components will be installed in same horizontal plane. If components are not to be installed in same horizontal plane, contact your Carrier representative for more information. For additional piping information, refer to Carrier System Design Manual, Part 3.



UNIT 50AH	060	072	096
OPERATING WEIGHT (lb)			
Base Unit	960	1214	1283
Evaporator/Condenser Sections	421/519	554/634	556/701
SHIPPING WEIGHT (lb)*	1093	1647	1716
REFRIGERANT TYPE		R-410A	
Operating Charge (lb-oz)†	8-8	6-6	6-6
COMPRESSOR — TYPE		Scroll	
Quantity...Model	1...ZPKP51K5E	2...ZP31K5E	2...ZP38K5E
Oil (oz)	42	25	42
HPS Setting (psig)		650 ± 7	
Cutout		Manual Reset	
Reset			
LPS Setting (psig)		75 ± 7	
Cutout		100 ± 7	
Reset			
CONDENSATE DRAIN CONNECTION		7/8...OD	
Size (in.)...Type			
CONDENSER COIL		Copper Tubes — Aluminum Fins	
Size (L x H) (in.)	90 x 30	40 x 30 (2 coils)	40 x 30 (2 coils)
Number of Rows...Fins/in.	2...12	2...20	2...20
CONDENSER FAN		Centrifugal — Belt Drive	
Nominal Cfm	3000	5200	6400
Blower Size (in.)	15 x 15	18 x 18	18 x 18
Motor Hp	0.33	1.00	1.50
Motor Rpm	1750	1750	1750
EVAPORATOR COIL		Copper Tubes — Aluminum Fins	
Size (L x H) (in.)	32 x 26	46 x 28	46 x 28
Number of Rows...Fins/in.	3...14	3...14	3...14
EVAPORATOR AIR FAN		Centrifugal — Belt Drive	
Nominal Cfm	2000	2400	3200
Blower Size (in.)	12 x 9	15 x 15	15 x 15
Motor Hp (Rpm)	0.33 (1750)	0.50 (1750)	0.75 (1750)
INDOOR-AIR FILTERS		Factory-Supplied Cleanable Type	
Number...Size (in.)	2...18 x 24 x 1	2...20 x 25 x 1	2...20 x 25 x 1
INTERCONNECTING TUBING SIZE			
Suction (Qty...in.)	1...7/8	1...5/8	1...7/8
Liquid (Qty...in.)	1...3/8	1...3/8	1...7/8
WATER CONNECTIONS			
Pipe Size (OD) (in.)	1 1/8	1 1/8	1 1/8

LEGEND

HPS — High-Pressure Switch
LPS — Low-Pressure Switch

*Shipping weights include base unit plus packaging.
†If components are to be split, additional refrigerant will be needed.

NOTE: If components are to be split, the maximum length of refrigerant tubing to be used is 50 equivalent ft, assuming components will be installed in same horizontal plane. If components are not to be installed in same horizontal plane, contact your Carrier representative for more information. For additional piping information, refer to Carrier System Design Manual, Part 3.

Options and accessories



ITEM	FACTORY-INSTALLED OPTION	FIELD-INSTALLED ACCESSORY
Hot Gas Bypass	X	
Hot Gas Reheat	X	
Air Side Economizer	X	
Freezestat	X	
High-Static Motor Upgrade	X	
Flooded Condenser	X	
Electric Duct Heaters		X
Thermostats		X
Disconnect		X
Externally Mounted Condensate Pump		X

Factory-installed options

Hot gas bypass — Hot gas bypass is available for extended capacity operation and to prevent coil freezing at low load conditions.

Hot gas reheat — When indoor air quality is a concern, a hot gas reheat coil can be ordered to help control humidity levels. Normally, bringing humidity levels down to acceptable levels requires cooling the air to relatively low temperatures producing uncomfortable conditions in the space. This option uses hot refrigerant gas to reheat the air and is controlled by space humidity levels only operating when needed.

Air-side economizer — Economizer will bring in fresh air to meet air quality needs.

Freezestat — The optional freezestat is a safety switch. Its purpose is to shut down a system or part of a system to protect the components. The freezestat is installed in the low voltage control circuit.

High-static motor upgrade — The base air conditioners are designed with the smallest motors for a variety of reasons. Typically the motor size is selected so that it will perform most efficiently under ARI conditions to get the maximum unit efficiency.

Since field conditions are typically diverse and may not be similar to ARI test conditions, upgraded motors may be required.

Upgraded motors may be required for higher external static pressure (ESP) needed for factory or field-installed accessories (dampers, heating coils, etc.) to achieve the required performance.

Units are designed with a fixed pulley on the blower and an adjustable sheave on the motor. The sheave turns open

(TO) or the components themselves may need to be changed to provide the desired performance.

Flooded condenser — The purpose of a flooded condenser is to hold back enough of the condensed liquid refrigerant so that some of the condenser surface is rendered inactive. This reduction of active condensing surface results in a rise in condensing pressure and sufficient liquid line pressure for normal system operation.

A three-way modulating valve and a receiver make up the flooded condenser refrigerant components.

The valve is field-installed in the liquid line after the condenser. The receiver is downstream of the valve. The valve limits the flow of liquid refrigerant from the condenser while at the same time regulating the flow of discharge gas around the condenser to the receiver.

Field-installed accessories

Electric duct heaters — A wide range of models is available from 5 to 15 kW, 208, 240 and 480-v, 3-ph units. The heaters mount easily in the 50AH discharge. The heater control box is accessible from the side of heater.

NOTE: Separate power source is required for all heaters.

Thermostats — A complete line of Carrier thermostats are available to meet the control requirements of every application. Thermostats with diagnostic and communication capability are available.

Disconnect — A disconnect switch will be provided for field installation.

Externally mounted condensate pump — A pump is provided for external mounting to remove condensate from the drain pan when required for the application.

Base unit dimensions — 50AH024-060



STANDARD UNIT

OPERATING WEIGHT DISTRIBUTION

UNIT	WEIGHT OF CORNER (lb)							
	A	B	C	D	E	F	G	H
50AH								
024	87	111	88	113	143	136	105	100
036	87	111	89	114	144	138	106	101
048	91	116	92	118	152	145	111	106
060	91	117	93	119	153	146	112	107

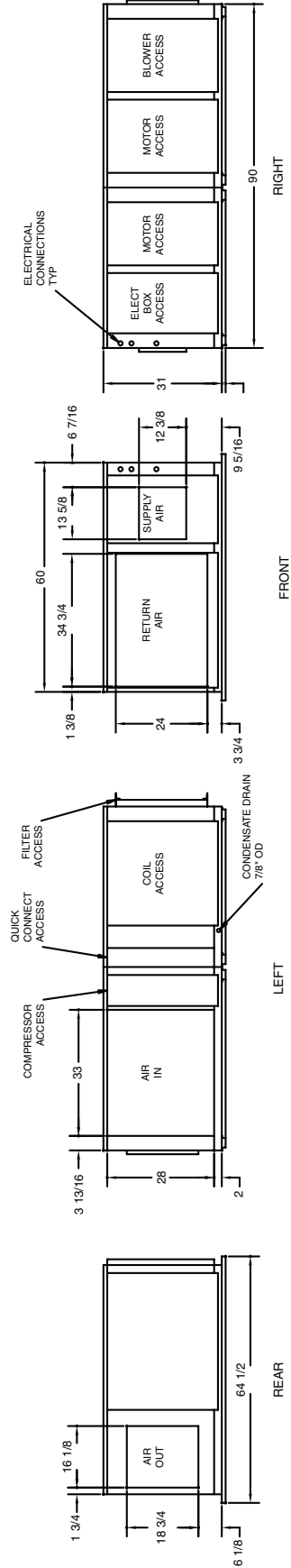
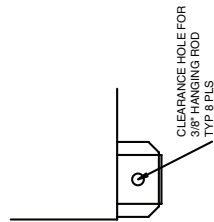
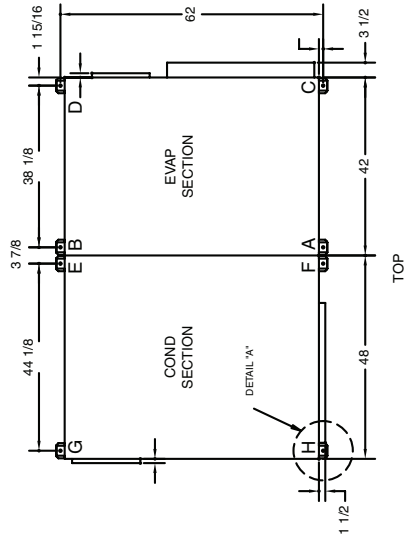
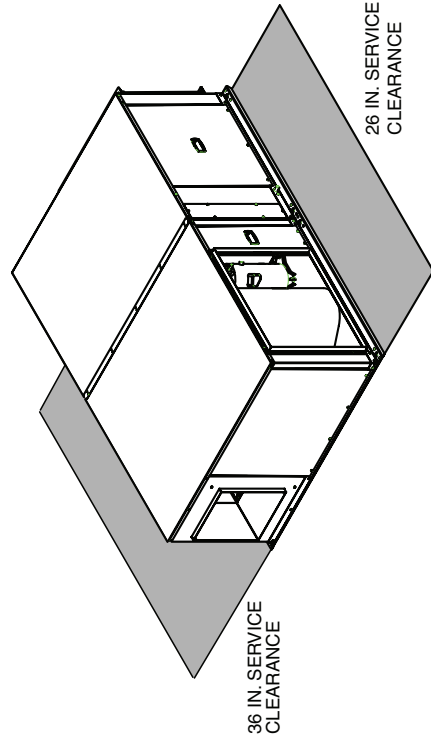

NOTE: Dimensions are in inches.

Base unit dimensions — 50AH024-060 (cont)



UNIT WITH FACTORY-INSTALLED AIR-SIDE ECONOMIZER

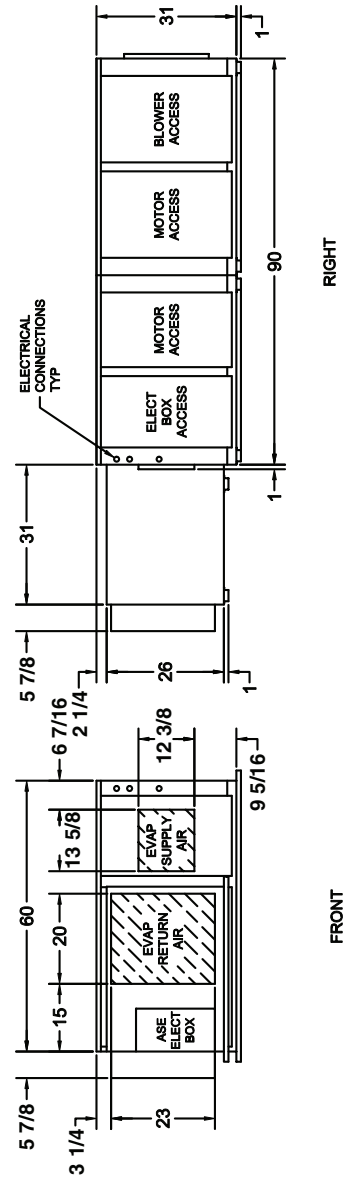
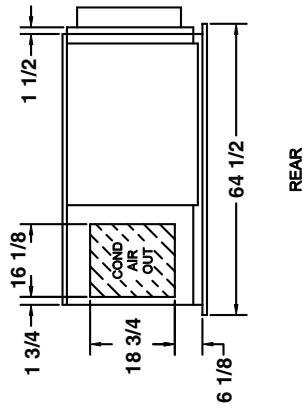
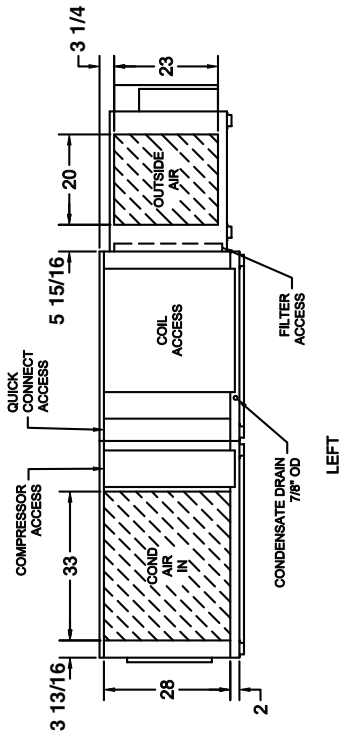
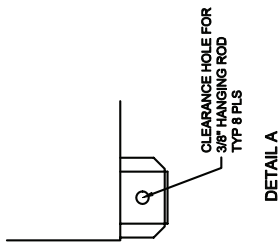
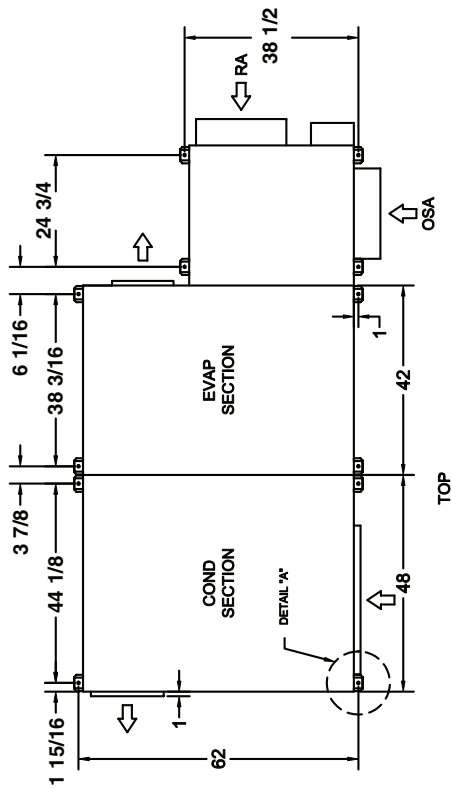

NOTE: Dimensions are in inches.

Base unit dimensions — 50AH072,096



STANDARD UNIT

OPERATING WEIGHT DISTRIBUTION

UNIT	WEIGHT OF CORNER (lb)							
	A	B	C	D	E	F	G	H
50AH								
072	125	128	149	152	126	128	188	192
096	126	129	149	153	139	142	208	212

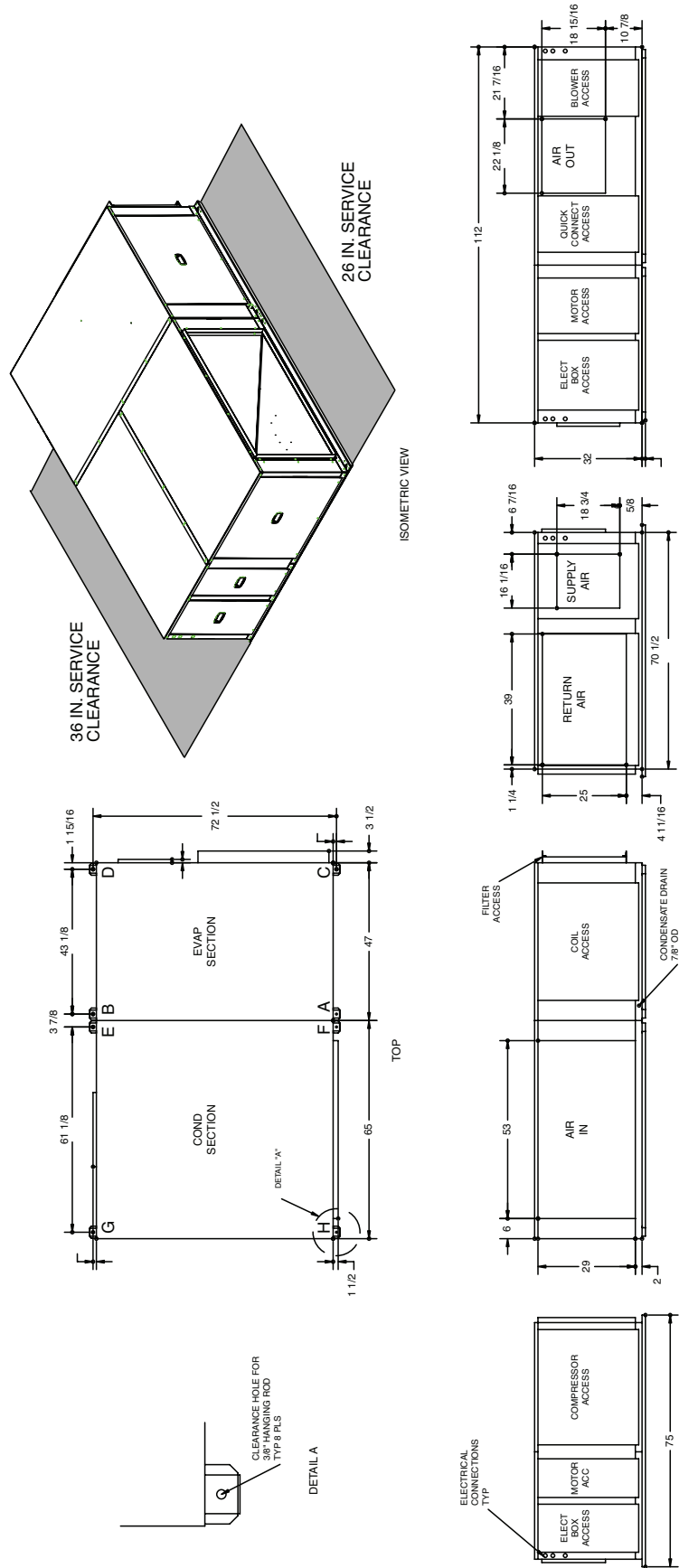

NOTE: Dimensions are in inches.

Base unit dimensions — 50AH072,096 (cont)



UNIT WITH FACTORY-INSTALLED AIR-SIDE ECONOMIZER

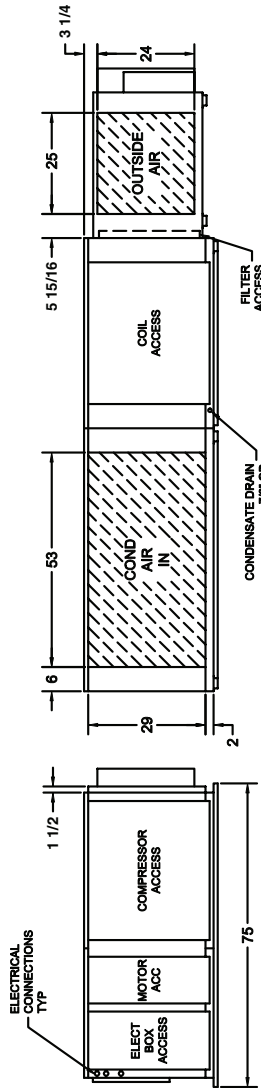
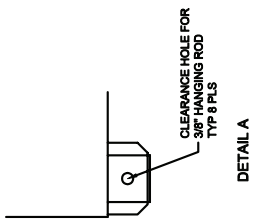
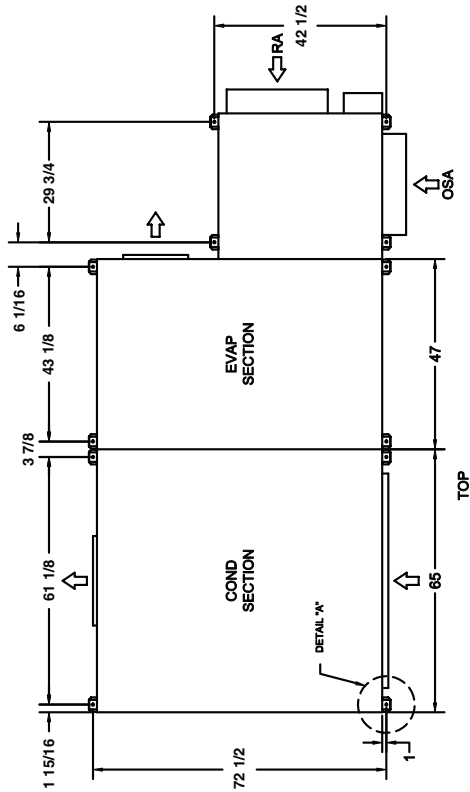

LEFT

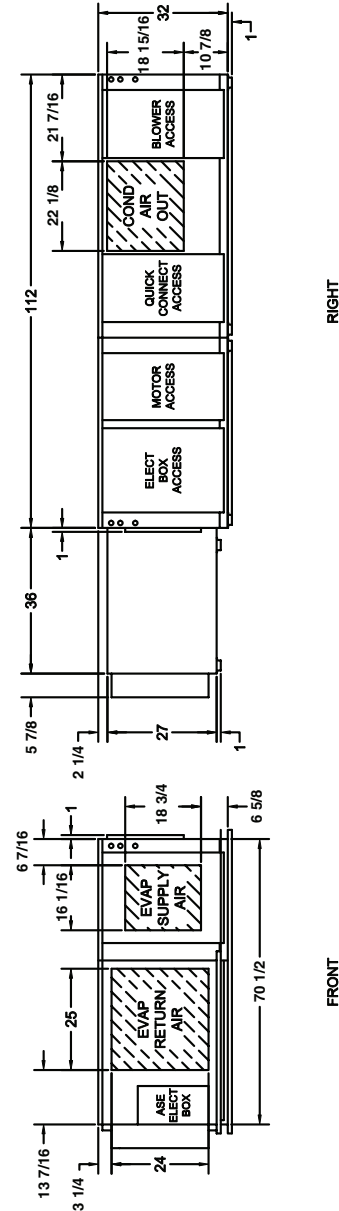

NOTE: Dimensions are in inches.

Selection procedure (with example)



I Determine cooling requirements at design conditions.

Given:

Gross Cooling Capacity

Required (TC) 36,000 Btuh

Sensible Heat Capacity (SHC) 27,000 Btuh

Temperature of Air Entering Condenser 95 F

Temperature of Air Entering

Evaporator 80 F edb/67 F ewb

Evaporator Air Quantity 1,200 cfm

External Static Pressure:

Condenser 0.50 in. wg

Evaporator (includes static pressure drop of factory-supplied filter

of 0.06 in. wg) 0.20 in. wg

II Select unit based upon required cooling capacity.

Enter cooling capacity table at temperature of air entering condenser of 95 F. The 50AHAC036 unit at 1200 cfm and 67 F ewb will provide a Total Capacity (TC) of 36,600 Btuh and a Sensible Heat Capacity (SHC) of 27,100 Btuh. Since the entering air is 80 F edb, an SHC correction is not required.

Performance data



GROSS COOLING CAPACITIES

50AH024

Temp Air Ent Condenser (F)		Evaporator Air Quantity — Cfm											
		700				800				900			
		Evaporator Air Ewb Temp (F)											
		72	67	62	60	72	67	62	60	72	67	62	60
85	TC	—	26.3	24.1	23.3	—	26.9	24.7	23.9	—	27.3	25.2	24.3
	SHC	—	18.3	18.4	17.7	—	19.4	19.6	18.8	—	20.5	20.7	19.9
	kW	—	1.51	1.50	1.49	—	1.54	1.53	1.52	—	1.56	1.54	1.54
95	TC	—	24.9	22.9	22.1	—	25.4	23.4	22.6	—	25.9	23.8	23.0
	SHC	—	17.8	17.8	17.1	—	18.8	19.0	18.3	—	19.9	20.1	19.3
	kW	—	1.70	1.68	1.68	—	1.73	1.71	1.71	—	1.75	1.73	1.73
105	TC	—	23.5	21.6	20.8	—	24.0	22.1	21.3	—	24.4	22.4	21.6
	SHC	—	17.2	17.2	16.5	—	18.2	18.4	17.6	—	19.3	19.5	18.6
	kW	—	1.91	1.89	1.89	—	1.94	1.92	1.92	—	1.96	1.94	1.94
115	TC	—	22.1	20.2	19.5	—	22.5	20.7	19.9	—	22.9	21.0	20.3
	SHC	—	16.5	16.6	15.9	—	17.7	17.8	17.0	—	18.8	18.9	18.1
	kW	—	2.15	2.14	2.13	—	2.18	2.16	2.16	—	2.20	2.18	2.17

50AH036

Temp Air Ent Condenser (F)		Evaporator Air Quantity — Cfm											
		1050				1200				1350			
		Evaporator Air Ewb Temp (F)											
		72	67	62	60	72	67	62	60	72	67	62	60
85	TC	41.0	37.8	34.8	33.6	—	38.6	35.5	34.4	—	39.3	36.3	35.1
	SHC	27.1	26.2	26.5	25.6	—	27.9	28.0	27.1	—	29.6	29.9	28.7
	kW	2.45	2.42	2.39	2.38	—	2.45	2.43	2.42	—	2.49	2.46	2.45
95	TC	38.9	35.9	32.9	31.8	—	36.6	33.8	32.7	—	37.3	34.3	33.2
	SHC	26.2	25.5	25.5	24.6	—	27.1	27.4	26.4	—	28.8	28.9	27.7
	kW	2.73	2.69	2.66	2.65	—	2.72	2.70	2.69	—	2.77	2.73	2.72
105	TC	36.9	33.9	31.2	30.1	—	34.7	31.9	30.8	—	35.2	32.4	31.3
	SHC	25.5	24.7	24.9	23.9	—	26.3	26.5	25.4	—	27.9	28.0	26.9
	kW	3.03	3.00	2.98	2.96	—	3.05	3.01	3.00	—	3.08	3.04	3.04
115	TC	34.8	32.0	29.0	28.3	—	32.6	29.9	28.9	—	33.1	30.4	29.3
	SHC	24.7	23.9	24.0	23.0	—	25.5	25.6	24.5	—	27.0	27.3	25.9
	kW	3.41	3.37	3.32	3.31	—	3.41	3.36	3.36	—	3.45	3.40	3.38

50AH048

Temp Air Ent Condenser (F)		Evaporator Air Quantity — Cfm											
		1400				1600				1800			
		Evaporator Air Ewb Temp (F)											
		72	67	62	60	72	67	62	60	72	67	62	60
85	TC	—	47.3	43.7	42.1	—	48.3	44.5	43.1	—	48.9	45.1	43.7
	SHC	—	34.7	35.0	33.4	—	37.0	37.0	35.6	—	38.9	39.2	37.6
	kW	—	3.10	3.08	3.06	—	3.08	3.05	3.04	—	3.11	3.08	3.07
95	TC	—	45.0	41.4	40.0	—	45.6	42.1	40.8	—	46.2	42.7	41.4
	SHC	—	33.7	33.9	32.5	—	35.7	36.0	34.6	—	37.8	38.0	36.5
	kW	—	3.43	3.41	3.40	—	3.40	3.38	3.37	—	3.44	3.41	3.40
105	TC	—	42.3	39.1	37.8	—	43.1	39.8	38.5	—	43.5	40.3	39.0
	SHC	—	32.4	32.8	31.5	—	34.9	34.9	33.5	—	36.7	37.0	35.6
	kW	—	3.81	3.79	3.78	—	3.79	3.76	3.76	—	3.82	3.80	3.79
115	TC	—	39.8	36.8	35.6	—	40.5	37.3	36.1	—	40.9	37.9	36.6
	SHC	—	31.5	31.8	30.4	—	33.8	33.9	32.5	—	35.7	36.0	34.3
	kW	—	4.25	4.24	4.23	—	4.23	4.21	4.20	—	4.26	4.24	4.24

50AH060

Temp Air Ent Condenser (F)		Evaporator Air Quantity — Cfm											
		1750				2000				1250			
		Evaporator Air Ewb Temp (F)											
		72	67	62	60	72	67	62	60	72	67	62	60
85	TC	66.0	61.3	56.4	54.5	—	62.2	57.7	55.9	—	63.2	58.4	56.5
	SHC	44.5	43.7	43.7	42.2	—	46.0	46.7	45.0	—	48.5	48.9	46.8
	kW	4.34	4.26	4.19	4.16	—	4.39	4.33	4.30	—	4.48	4.40	4.36
95	TC	62.8	58.0	53.7	51.9	—	59.2	54.5	52.9	—	59.9	55.5	53.5
	SHC	43.4	42.0	42.6	41.0	—	44.8	44.9	43.4	—	47.2	47.7	45.5
	kW	4.83	4.73	4.66	4.63	—	4.88	4.79	4.77	—	4.95	4.88	4.82
105	TC	59.4	55.0	50.7	49.1	—	55.9	51.7	49.9	—	56.4	52.4	50.7
	SHC	42.2	40.9	41.2	39.6	—	43.4	43.8	41.9	—	45.8	46.2	44.2
	kW	5.38	5.29	5.21	5.18	—	5.43	5.37	5.30	—	5.52	5.43	5.41
115	TC	55.8	51.7	47.8	46.2	—	52.6	48.7	47.0	—	53.0	50.3	46.8
	SHC	40.6	39.5	39.8	38.1	—	42.1	42.6	40.5	—	44.0	47.8	40.9
	kW	6.03	5.92	5.87	5.85	—	6.08	5.98	5.98	—	6.10	6.00	6.03



50AH072

Temp Air Ent Condenser (F)		Evaporator Air Quantity — Cfm											
		2100				2400				2700			
		Evaporator Air Ewb Temp (F)											
		72	67	62	60	72	67	62	60	72	67	62	60
85	TC	—	79.8	73.2	70.7	—	81.7	74.9	72.3	—	83.0	76.2	73.6
	SHC	—	55.8	56.1	54.1	—	59.5	59.6	57.3	—	62.4	62.7	60.4
	kW	—	5.19	5.14	5.13	—	5.23	5.20	5.18	—	5.31	5.26	5.25
95	TC	—	75.8	69.5	67.0	—	77.4	71.0	68.6	—	78.8	72.3	69.7
	SHC	—	54.2	54.3	52.3	—	57.4	57.6	55.6	—	60.9	61.3	58.4
	kW	—	5.71	5.66	5.66	—	5.77	5.73	5.70	—	5.84	5.79	5.78
105	TC	—	71.7	65.7	63.3	—	73.2	67.0	64.7	—	74.2	68.2	65.8
	SHC	—	52.5	52.7	50.5	—	55.9	55.9	53.8	—	58.7	59.3	56.9
	kW	—	6.33	6.27	6.28	—	6.38	6.34	6.32	—	6.46	6.42	6.39
115	TC	—	67.5	61.8	59.6	—	68.7	63.0	60.8	—	69.9	64.0	61.7
	SHC	—	50.5	50.7	48.9	—	53.7	54.1	51.8	—	57.3	57.4	54.8
	kW	—	7.05	7.01	6.96	—	7.09	7.06	7.04	—	7.16	7.11	7.11

50AH096

Temp Air Ent Condenser (F)		Evaporator Air Quantity — Cfm											
		2800				3200				3600			
		Evaporator Air Ewb Temp (F)											
		72	67	62	60	72	67	62	60	72	67	62	60
85	TC	—	95.0	87.4	84.5	—	96.8	89.1	86.1	—	98.1	90.3	87.5
	SHC	—	68.6	69.0	66.5	—	72.8	73.3	70.4	—	76.7	76.9	74.2
	kW	—	7.21	7.19	7.18	—	7.25	7.22	7.21	—	7.48	7.47	7.45
95	TC	—	90.3	83.1	80.2	—	91.9	84.5	81.8	—	93.0	85.8	82.8
	SHC	—	66.5	67.1	64.5	—	70.7	70.9	68.4	—	74.3	75.2	71.6
	kW	—	7.90	7.87	7.85	—	7.94	7.91	7.89	—	8.18	8.15	8.14
105	TC	—	85.3	78.5	75.9	—	86.9	78.9	77.1	—	88.0	81.0	78.2
	SHC	—	64.3	64.7	62.4	—	68.7	68.8	65.9	—	72.6	73.0	69.5
	kW	—	8.67	8.63	8.61	—	8.70	8.67	8.65	—	8.94	8.91	8.89
115	TC	—	80.5	74.0	71.4	—	81.8	75.2	72.5	—	82.7	76.2	73.7
	SHC	—	62.6	62.9	60.3	—	66.6	67.0	63.7	—	70.1	70.4	67.7
	kW	—	9.51	9.46	9.44	—	9.54	9.50	9.49	—	9.78	9.75	9.72

LEGEND

- edb — Entering dry-bulb
- Ewb — Entering Wet-Bulb
- kW — Compressor Motor Power Input (kilowatts)
- SHC — Gross Sensible Heat Capacity (1000 Btuh)
- TC — Gross Total Cooling Capacity (1000 Btuh)

NOTE: Performance based on nominal condenser airflow listed in physical data table on page 4.

Performance data (cont)



EVAPORATOR FAN PERFORMANCE

UNIT SIZE 50AH	CFM	EXTERNAL STATIC PRESSURE (in. wg)											
		0.2		0.4		0.6		0.8		1.0		1.2	
		Rpm	Bhp	Rpm	Bhp	Rpm	Bhp	Rpm	Bhp	Rpm	Bhp	Rpm	Bhp
024	900	509	0.11	632	0.14	739	0.19	833	0.24	919	0.30	997	0.37
	800	495	0.07	623	0.12	733	0.17	829	0.22	915	0.28	993	0.34
	700	470	0.06	604	0.10	717	0.14	814	0.19	901	0.25	979	0.31
036	1350	550	0.17	651	0.23	744	0.29	831	0.36	912	0.43	988	0.50
	1200	526	0.14	635	0.19	734	0.25	825	0.31	908	0.38	986	0.45
	1050	510	0.11	627	0.16	731	0.21	824	0.27	910	0.33	988	0.40
048	1800	607	0.29	685	0.36	760	0.43	832	0.50	902	0.58	970	0.66
	1600	566	0.22	652	0.28	734	0.35	813	0.42	888	0.49	960	0.56
	1400	537	0.17	632	0.23	722	0.29	806	0.35	886	0.42	962	0.49
060	2250	640	0.44	715	0.52	786	0.61	852	0.70	917	0.79	979	0.88
	2000	588	0.32	670	0.40	747	0.48	819	0.56	889	0.64	956	0.73
	1750	552	0.24	642	0.31	725	0.38	803	0.46	878	0.53	950	0.61
072	2700	461	0.36	543	0.47	619	0.60	689	0.75	753	0.90	813	1.07
	2400	449	0.29	537	0.40	616	0.53	688	0.67	753	0.83	812	1.00
	2100	435	0.24	529	0.34	611	0.47	683	0.61	748	0.76	807	0.92
096	3600	555	0.74	618	0.87	680	1.01	740	1.17	797	1.34	852	1.82
	3200	514	0.66	584	0.80	652	0.81	707	0.94	769	1.10	826	1.28
	2800	448	0.37	552	0.51	626	0.64	695	0.79	759	0.95	818	1.12

CONDENSER FAN PERFORMANCE

UNIT SIZE 50AH	CFM	EXTERNAL STATIC PRESSURE (in. wg)											
		0.0		0.1		0.2		0.3		0.4		0.5	
		Rpm	Bhp	Rpm	Bhp	Rpm	Bhp	Rpm	Bhp	Rpm	Bhp	Rpm	Bhp
024	1700	247	0.07	255	0.07	262	0.08	269	0.08	277	0.08	284	0.09
036	2000	276	0.11	282	0.11	289	0.12	295	0.12	301	0.12	307	0.13
048	2500	251	0.17	305	0.18	357	0.22	408	0.27	456	0.32	501	0.37
060	3000	287	0.22	334	0.28	378	0.33	421	0.38	464	0.43	505	0.49
072	5200	367	0.68	438	0.89	464	0.98	490	1.07	516	1.16	542	1.25
090	6400	448	1.26	524	1.59	546	1.7	568	1.81	589	1.91	610	2.02

BELT DRIVE EVAPORATOR FAN PERFORMANCE (Special Order Only, Pricing and ordering on related price pages.)

CFM	UNIT SIZE — 50AH			
	048		060	
	ESP	Fan kW	ESP	Fan kW
1800	—	—	—	—
1850	—	—	—	—
1900	—	—	—	—
1950	.81	1.03	—	—
2000	.72	1.05	—	—
2050	.63	1.07	—	—
2100	.55	1.08	1.02	1.17
2150	.47	1.11	.93	1.21
2200	.42	1.14	.84	1.24
2250	.34	1.17	.75	1.27

LEGEND

ESP — External Static Pressure (in. wg)
kW — Total Fan Power Motor Input (kilowatts)

NOTE: Pulley setting must be adjusted to limit cfm to 450 cfm/ton maximum. Unit operation beyond that limit may result in blow-off and condensate problems.



GLYCOL CAPACITY CORRECTION FACTORS

ENTERING FLUID TEMPERATURE		ETHYLENE GLYCOL											
		% by Weight						% by Volume					
C	F	0	10	20	30	40	50	0	10	20	30	40	50
0	32	1	0.958	0.932	0.904	0.871	0.833	1	0.953	0.927	0.897	0.862	0.823
5	41	1	0.962	0.937	0.909	0.876	0.839	1	0.957	0.932	0.903	0.868	0.830
10	50	1	0.965	0.941	0.913	0.882	0.845	1	0.961	0.936	0.906	0.873	0.835
15	59	1	0.967	0.944	0.917	0.886	0.849	1	0.963	0.939	0.911	0.877	0.840
20	68	1	0.970	0.947	0.921	0.890	0.854	1	0.966	0.942	0.914	0.882	0.845
25	77	1	0.972	0.949	0.924	0.894	0.859	1	0.968	0.945	0.918	0.886	0.850
30	86	1	0.973	0.952	0.928	0.898	0.863	1	0.970	0.948	0.922	0.890	0.854
35	95	1	0.975	0.955	0.930	0.901	0.867	1	0.972	0.951	0.924	0.894	0.858
40	104	1	0.977	0.957	0.933	0.905	0.871	1	0.974	0.954	0.927	0.898	0.863
45	113	1	0.978	0.960	0.936	0.909	0.876	1	0.976	0.956	0.931	0.901	0.868
50	122	1	0.980	0.962	0.939	0.912	0.880	1	0.977	0.959	0.934	0.905	0.872

ENTERING FLUID TEMPERATURE		PROPYLENE GLYCOL											
		% by Weight						% by Volume					
C	F	0	10	20	30	40	50	0	10	20	30	40	50
0	32	1	0.977	0.960	0.939	0.910	0.874	1	0.974	0.957	0.934	0.903	0.864
5	41	1	0.980	0.965	0.944	0.915	0.880	1	0.978	0.962	0.938	0.908	0.870
10	50	1	0.983	0.968	0.948	0.921	0.885	1	0.981	0.966	0.943	0.913	0.875
15	59	1	0.985	0.971	0.952	0.924	0.889	1	0.984	0.969	0.947	0.917	0.880
20	68	1	0.987	0.974	0.954	0.928	0.893	1	0.986	0.971	0.949	0.921	0.884
25	77	1	0.989	0.976	0.957	0.931	0.897	1	0.987	0.974	0.952	0.924	0.888
30	86	1	0.991	0.979	0.960	0.934	0.900	1	0.990	0.976	0.955	0.927	0.891
35	95	1	0.993	0.981	0.963	0.937	0.904	1	0.992	0.979	0.958	0.930	0.896
40	104	1	0.994	0.983	0.965	0.940	0.908	1	0.993	0.981	0.960	0.933	0.900
45	113	1	0.995	0.985	0.968	0.943	0.911	1	0.995	0.983	0.963	0.936	0.903
50	122	1	0.996	0.987	0.970	0.946	0.915	1	0.996	0.985	0.966	0.940	0.906

Controls

Operating sequence

Cooling — When the thermostat calls for cooling, the indoor (evaporator) fan relay is energized and starts the evaporator fan. Compressor contactor is energized to start compressor and condenser fan (up to a 5-minute delay on single-phase units). When room thermostat is satisfied, the evaporator fan, compressor, and condenser fan shut off.

Continuous fan operation — The thermostat can be set for continuous operation by setting the fan switch to ON.

Air-side economizer — The optional air-side economizer utilizes outside air as much as possible for temperature and humidity control in the conditioned spaces.

To ensure that outside conditions are suitable for economizer operation, an enthalpy sensor, mounted in a position where it is continuously exposed to the ambient air, senses if a call for cooling is best answered by mechanical cooling or by a mixture of outside and re-circulated air. If the system brings in a continuous supply of fresh air, the sensing unit can be mounted on the duct with the sensor in the airstream.

The enthalpy sensor measures both humidity and temperature. The combination of both humidity and temperature determines the total heat content of the air.

When these conditions meet the setting selected on the enthalpy sensing unit, a SPDT switch is energized and a call for cooling from the first stage of the room thermostat is then directed to the damper controller. The controller is usually mounted in the conditioned space near the regular thermostat. The damper controller has its own temperature sensor, which causes the unit to send a variable signal to the damper motor(s), depending on the difference between the sensed temperature and the selected setting on the controller.

This signal controls the opening ratio of the outside and re-circulated air dampers, resulting in the correct amount of outside air that must be introduced into the room to maintain the selected temperature that has been set on the damper controller.

Some accommodation must be made to exhaust the excess air, brought into the conditioned spaces from the outside through the economizer. In the case of a full economizer installation, this can be as much as the total volume of air circulated in normal cooling operation.

When outside conditions are no longer suitable for cooling the conditioned space, the outdoor air enthalpy sensor will return control of room temperature to the regular room thermostat, which will then cycle the compressors on and off as required to maintain the set space temperature.

Electrical data



UNIT 50AH	V-PH (60 Hz)	VOLTAGE RANGE		COMPRESSOR		FAN MOTORS								POWER SUPPLY			
		Min	Max	RLA	LRA	Evaporator (Standard)		Evaporator (High Static)		Condenser (Standard)		Condenser (High Static)		Standard Motor		High Static Motor	
						Hp	FLA	Hp	FLA	Hp	FLA	Hp	FLA	Min Ckt Amps	MOC Amps	Min Ckt Amps	MOC Amps
024	208/230-1	187	254	13.5	58	1/4	1.25	1/3	1.7	1/3	1.70	1/2	2.50	19.8	35	21	35
036	208/230-1	187	254	16.7	79	1/3	1.70	1/2	2.5	1/3	1.70	1/2	2.50	24.3	40	26	45
	208/230-3	187	254	10.4	73	1/3	1.30	1/2	1.8	1/3	1.30	1/2	1.80	15.6	25	17	25
	460-3	414	508	5.8	38	1/3	0.65	1/2	0.9	1/3	0.65	1/2	0.90	8.6	15	9	15
048	208/230-1	187	254	19.9	109	1/3	1.70	1/2	2.5	1/3	1.70	1/2	2.50	28.3	50	30	50
	208/230-3	187	254	13.6	83	1/3	1.30	1/2	1.8	1/3	1.30	1/2	1.80	19.6	35	21	35
	460-3	414	508	6.1	41	1/3	0.65	1/2	0.9	1/3	0.65	1/2	0.90	8.9	15	9	15
060	208/230-1	187	254	26.4	134	1/3	1.70	1/2	2.5	1/3	1.70	1/2	2.50	36.4	65	38	65
	208/230-3	187	254	16.0	110	1/3	1.30	1/2	1.8	1/3	1.30	1/2	1.80	22.6	40	24	40
	460-3	414	508	7.8	52	1/3	0.65	1/2	0.9	1/3	0.65	1/2	0.90	11.1	20	12	20
072*	208/230-1	187	254	16.7	79	1/2	2.50	3/4	3.2	1	4.20	1 1/2	6.50	44.3	60	47	65
	208/230-3	187	254	10.4	73	1/2	1.80	3/4	2.4	1	3.20	1 1/2	4.80	28.4	40	31	40
	460-3	414	508	5.8	38	1/2	0.90	3/4	1.2	1	1.60	1 1/2	2.40	15.6	20	17	20
	575-3	518	632	3.8	37	1/2	0.80	3/4	1.1	1	1.50	1 1/2	2.00	10.9	15	12	15
096*	208/230-1	187	254	19.9	109	3/4	3.20	1	4.2	1 1/2	6.50	2	8.20	54.5	75	57	75
	208/230-3	187	254	13.6	83	3/4	2.40	1	3.2	1 1/2	4.80	2	6.00	37.8	50	40	55
	460-3	414	508	6.1	41	3/4	1.20	1	1.6	1 1/2	2.40	2	2.90	17.3	25	18	25
	575-3	518	632	4.2	33	3/4	1.10	1	1.5	1 1/2	2.00	2	2.25	12.6	15	13	15

LEGEND

- HACR — Heating, Air Conditioning, and Refrigeration
- Hp — Horsepower
- FLA — Full Load Amps
- LRA — Locked Rotor Amps
- MOC — Maximum Overcurrent Protection (HACR breaker)
- RLA — Rated Load Amps



*Unit has two compressors.

Typical wiring schematic



50AH024-060 (SINGLE COMPRESSOR) UNITS

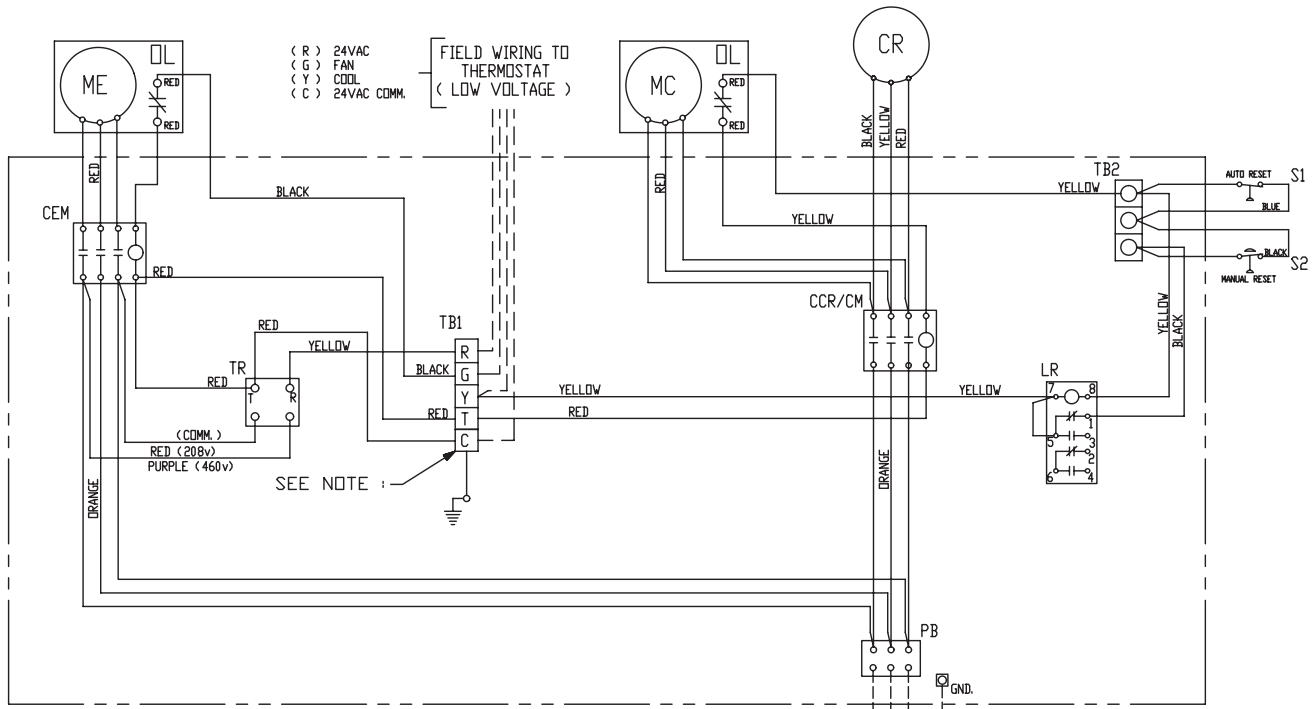

* TRANSFORMER FOR 208-230 VOLT UNIT IS WIRED FOR 208 VOLT OPERATION, FOR 230 VOLT OPERATION DISCONNECT AND TAPE 208 VOLT PRIMARY WIRE AND REPLACE WITH 230 VOLT WIRE. (SEE TRANSFORMER MARKING)

208-230-460v/3ph/60cy
POWER IN FROM
FUUSED DISCONNECT
(FIELD WIRING)

- CAUTION**
- ALL FIELD PROVIDED CONTROL VOLTAGE WIRING MUST BE A MINIMUM OF #18 AWG.
 - VOLTAGE DROP MUST NOT EXCEED 1 VAC
 - DO NOT POWER AUXILIARY DEVICES FROM UNIT'S TRANSFORMER...UNLESS SPECIFIED IN THE WIRING DIAGRAM.
 - TERMINAL MARKED 'C' IS USED WITH A PROGRAMMABLE THERMOSTAT

LEGEND

- | | | | |
|---------------|---|-------|----------------|
| AWG | — American Wire Gage | ———— | Factory Wiring |
| CCR/CM | — Contactor, Compressor and Condenser Fan | ----- | Field Wiring |
| CEM | — Contactor, Evaporator Fan Motor | | |
| CR | — Compressor (Scroll) | | |
| GND | — Ground | | |
| LR | — Lockout Relay, Compressor | | |
| MC | — Motor, Condenser Fan | | |
| ME | — Motor, Evaporator Fan | | |
| OL | — Overload Protection | | |
| PB | — Power Block | | |
| S | — Switch | | |
| TB | — Terminal Block | | |
| TD | — Time Delay (Compressor) | | |
| TR | — Transformer | | |

Typical wiring schematic (cont)



50AH072-096 (DUAL COMPRESSOR) UNITS

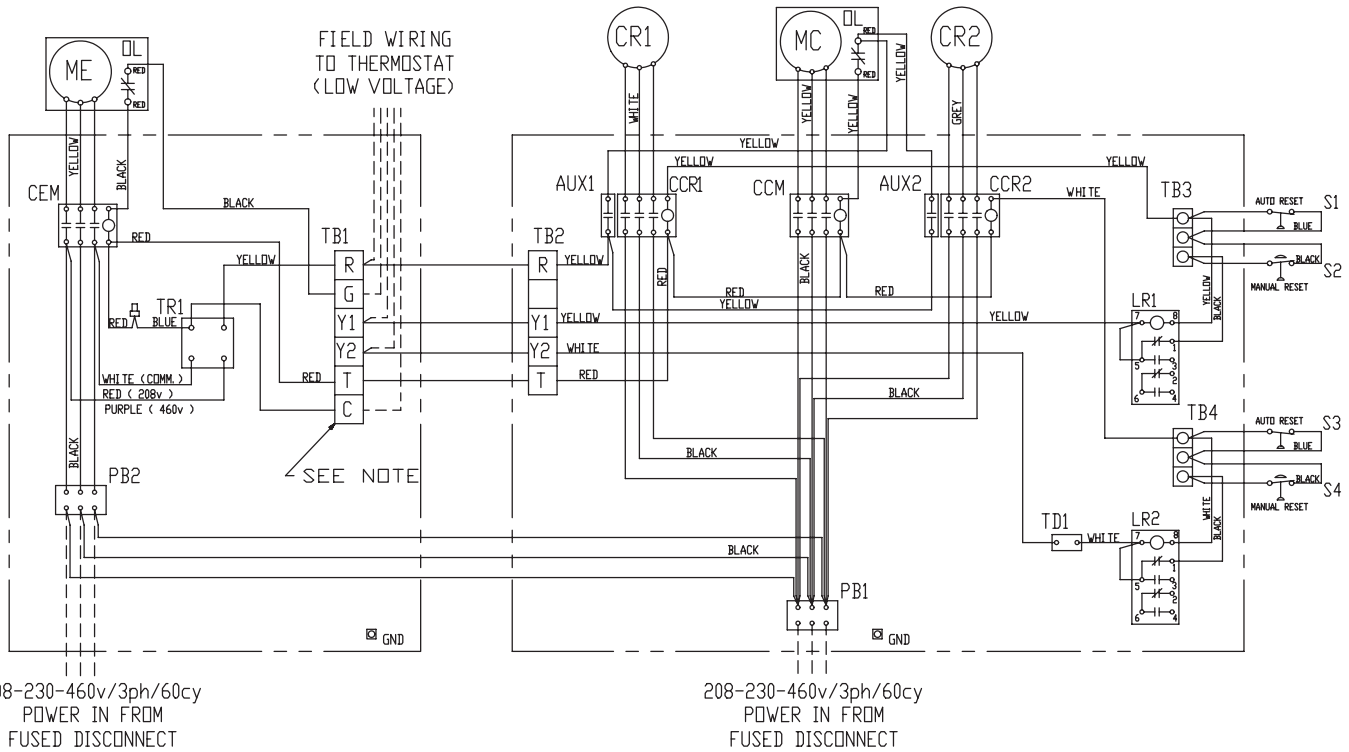

- NOTES:**
1. TRANSFORMER FOR 208-230 VOLT UNIT IS WIRED FOR 208 VOLT OPERATION. FOR 230 VOLT OPERATION DISCONNECT AND TAPE 208 VOLT PRIMARY WIRE AND REPLACE WITH 230 VOLT WIRE. (SEE TRANSFORMER MARKING)
 2. TERMINAL MARKED "C" IS USED WITH A PROGRAMMABLE THERMOSTAT

- CAUTION:**
- ALL FIELD PROVIDED CONTROL VOLTAGE WIRING MUST BE A MINIMUM OF #18 AWG
 - VOLTAGE DROP MUST NOT EXCEED 1 VAC
 - DO NOT POWER AUXILIARY DEVICES FROM UNIT'S TRANSFORMER... (UNLESS SPECIFIED ON THE WIRING DIAGRAM)

LEGEND

- | | | | |
|---------------|---|-------|----------------|
| AUX | — Auxiliary Contact | ———— | Factory Wiring |
| AWG | — American Wire Gauge | ----- | Field Wiring |
| CCR/CM | — Contactor, Compressor and Condenser Fan | | |
| CEM | — Contactor, Evaporator Fan Motor | | |
| CR | — Compressor (Scroll) | | |
| GND | — Ground | | |
| LR | — Lockout Relay, Compressor | | |
| MC | — Motor, Condenser Fan | | |
| ME | — Motor, Evaporator Fan | | |
| OL | — Overload Protection | | |
| PB | — Power Block | | |
| S | — Switch | | |
| TB | — Terminal Block | | |
| TD | — Time Delay (Compressor) | | |
| TR | — Transformer | | |

Typical piping and wiring

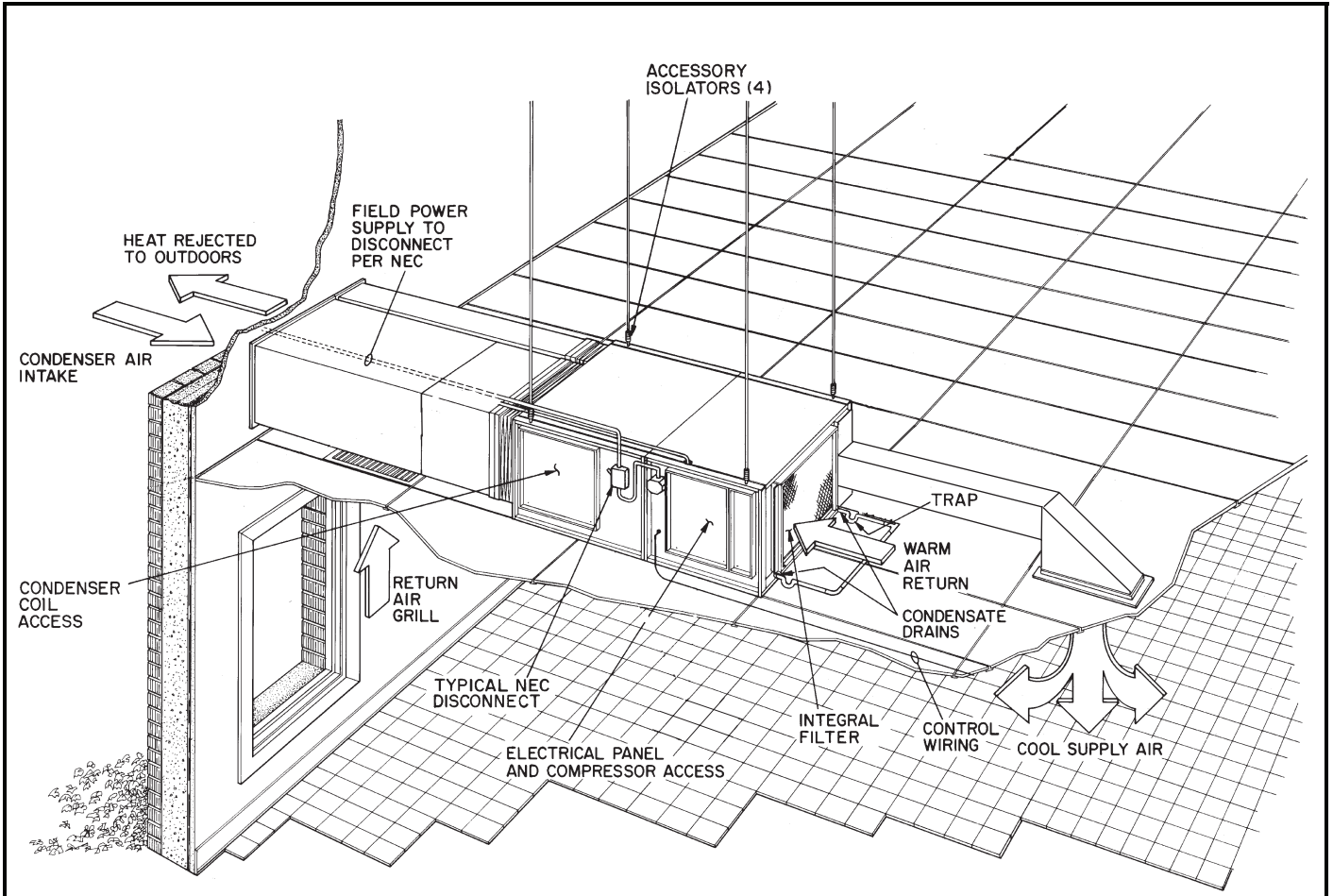

LEGEND

NEC — National Electrical Code

NOTES:

1. Wiring and piping shown are not intended for or to include all details for specific installation.
2. All wiring must comply with applicable local and national codes.

3. All piping must follow standard refrigerant piping techniques. Refer to Carrier System Design Manual, Part 3, for details.
4. For other installation details refer to Installation Instructions.
5. If unit sections are field split, 8 threaded support rods are required.
6. Ensure condenser air recirculation is minimized.

Application data



LOW AMBIENT OPTIONS TEMPERATURE OPERATING LIMITS (F)

UNIT 50AH	024-096
Fan Cycling Pressure Switch	35 F MIN
Flooded Condenser with Head Pressure Control Valve	-20 F MIN

Field splitting instructions — If components are split, maximum length of refrigerant tubing to be used is 75 ft, assuming components are installed in same horizontal plane. Condenser may be mounted up to 20 ft above evaporator. Liquid line tubing is 3/8-in. OD copper tubing, and discharge line is 1/2-in. OD copper tubing. For additional piping information, refer to Carrier System Design Manual, Part 3. Units should always be within line of sight from each other, or separate NEC (National Electrical Code) disconnects will be required. Junction boxes should be installed in both the evaporator and condenser sections adjacent to D-shaped grommets, to provide a location to splice the outdoor-fan motor factory wiring (no. 16 AWG [American Wire Gage], 4/64-in. thick insulation). Field wiring should be a minimum of no. 16 AWG, 4/64-in. thick

insulation. Check all applicable electrical codes to ensure proper compliance.

Unit configuration — The unit can be installed in different configurations based on the application. See unit configuration figure below.

Freezestat — The freezestat device is used to protect coils and airstreams. The freezestat can be applied to a refrigerant coil or a coil containing a fluid, such as a hot water coil.

The freezestat clamps onto the coil return bend. The device is designed to open the contacts at 35 F and will automatically close when the temperature being sensed reaches 55 F.

On a coil that has refrigerant inside the tubes, this helps to make sure that no frost occurs on the coil which can impede the airflow and cause problems such as a blower motor failure. A worst case situation would be that the coil would frost over and no heat exchange would occur and liquid refrigerant would go back to the compressor and cause damage.

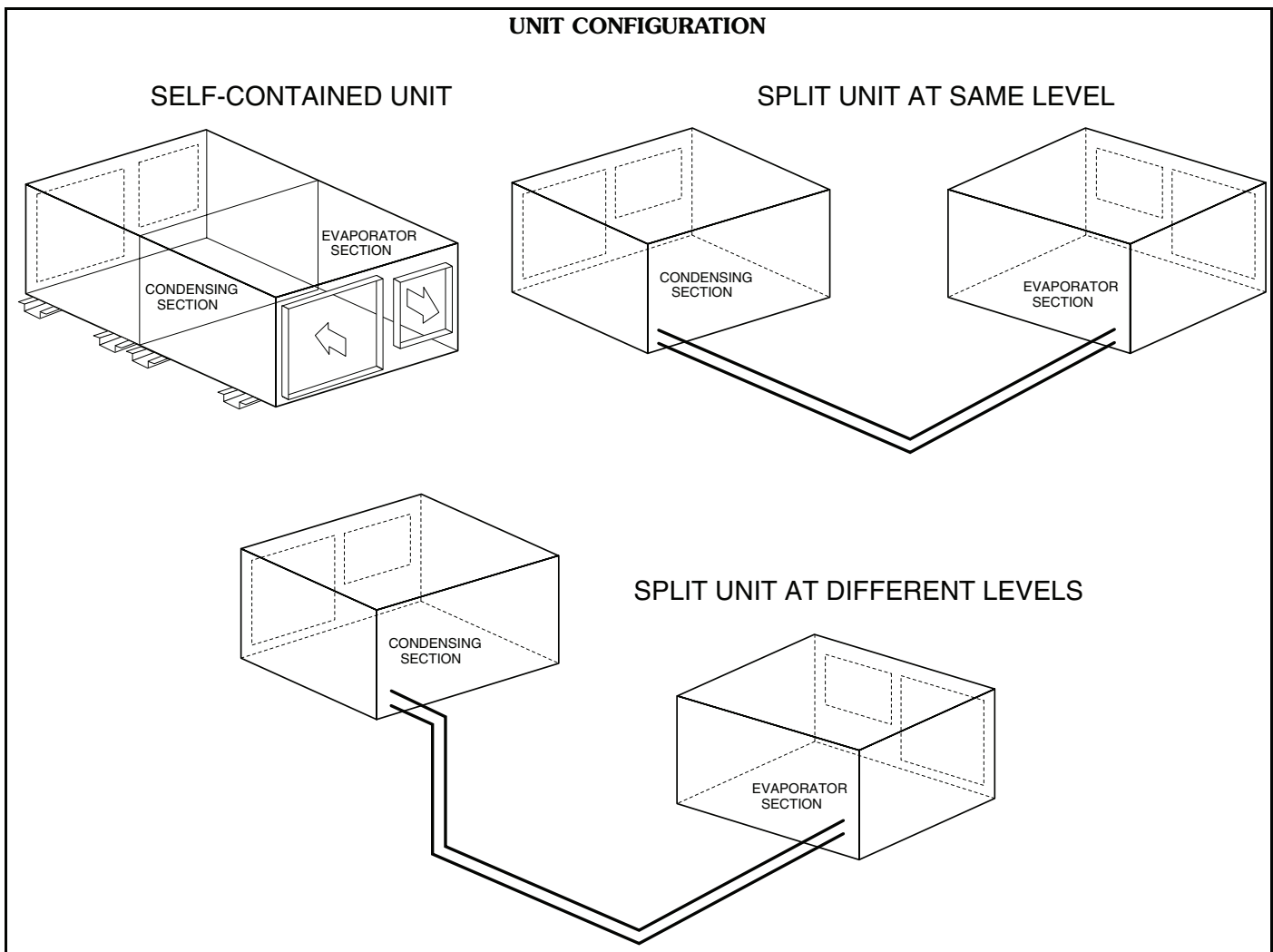

When the safety switch opens, the freestat will shut down the compressor. The blower will continue to run to help heat the coil back up to the point where the switch will close and the system will resume operation.

In coils that contain a fluid, such as water or glycol, it is important to protect the fluid from freezing. This is typically the case when the coil will be subjected to exposure of outside air in a cold climate. If the fluid were to freeze in a coil, the tubes will rupture and cause a failure which can be very costly to repair.

When applied with a heat exchanger carrying fluid, should the switch open, it will typically close the valve that is feeding the fluid to the coil. In some cases dampers may also be closed that are used to bring in the outside air. Again, the blower will continue to operate to warm up the coil.

Flooded Condenser — The purpose of a flooded condenser is to hold back enough of the condensed liquid refrigerant so that some of the condenser surface is rendered inactive. This reduction of active condensing surface results in a rise in condensing pressure and sufficient liquid line pressure for normal system operation.

During periods of low ambient operation, the receiver pressure falls until it approaches the setting of the control point of the valve (typically 295 psig for R-410A). The

valve then throttles to restrict the flow of liquid from the condenser. This raises the condenser pressure. Since it is the receiver pressure that is being maintained, the valve will then start to throttle open the discharge port when the differential pressure between the condensing pressure and the receiver pressure exceeds 20 psi. The hot discharge gas serves to heat up the cold liquid being passed from the condenser to the receiver. Thus the liquid reaches the receiver warm and with sufficient pressure to assure proper expansion valve operation.

The receiver is required to hold all of the additional liquid refrigerant in the system, since the refrigerant will be returned to the receiver when the high ambient conditions exist.

Hot gas bypass — On many air conditioning and refrigeration systems it is desirable to limit the evaporating pressure during periods of low load either to prevent coil icing or to avoid operating the compressor at a lower suction pressure than it was designed to operate. Various methods have been used to achieve this result. Carrier utilizes the Hot Gas Bypass method to bypass a portion of the hot discharge gas directly into the low side through a modulating control valve. Hot gas bypass has been a practical and economical solution to low load applications.

Guide specifications



Indoor Packaged Unit

HVAC Guide Specifications — Section 15787

Size Range: **2 to 8 Tons, Nominal**

Carrier Model Number: **50AH**

Part 1 — General

1.01 SYSTEM DESCRIPTION

Indoor mounted, electrically controlled packaged horizontal cooling unit utilizing a hermetic type scroll compressor.

1.02 QUALITY ASSURANCE

- A. Unit shall be certified in accordance with ARI Standard 210/240 (sizes 024-060) or 340/360 (sizes 072 and 096), latest edition.
- B. Unit shall be ETL listed and carry a ETL label.
- C. Unit shall be CSA approved through ETL.
- D. Unit shall be factory run-tested to ensure proper performance prior to delivery.

1.03 DELIVERY, STORAGE, AND HANDLING

- A. Unit shall be shipped completely assembled and ready to operate.
- B. Unit shall be shipped factory charged with R-410A refrigerant.
- C. Unit shall be stored and handled in accordance with the unit manufacturer's instructions.

Part 2 — Products

2.01 EQUIPMENT

A. General:

Factory assembled horizontal, single-piece, air-cooled, indoor, ceiling plenum mounted electric cooling unit. Contained within the unit enclosure shall be all factory wiring, piping, controls, refrigerant charge (R-410A), and special features required prior to start-up.

B. Unit Cabinet:

1. Constructed of scratch resistant, heavy duty, 18 gage galvanized steel.
2. Interior shall be insulated with 1/2-in. thick fiberglass lined thermal acoustical insulation of 1 lb density.
3. Equipped with 3 same side access panels and 2 bottom hanging removable doors to facilitate ease of maintenance. Side panels allow access to the control box, refrigeration components, and condenser coil. Control box shall be hinged allowing access to the compressor and pressure switches. Bottom doors shall allow access to and easy removal of the condenser and evaporator motors and blower assemblies.
4. Equipped with a 304 stainless steel drain pan and two 3/4-in. threaded condensate drain connections below the evaporator coil and one 3/4-in. threaded connection for condenser coil wash down. Connections shall be factory plugged for field removal.

5. Field splittable through the removal of 4 bolts and extending refrigerant piping and wiring to allow remote horizontal or vertical condenser mounting.
6. Unit shall have an integral hanging bracket requiring only 4 threaded rods (8 if unit is split) run to the top flange of the unit for hanging, eliminating need for external hanger brackets.
7. Contains junction box for power connection and opening for routing of control wiring.

C. Fans:

1. Evaporator:

- a. Blower shall be of the forward-curved, centrifugal, belt drive type.
- b. Motor shall have permanently lubricated bearings.
- c. Motor shall have adjustable motor mounts.
- d. Water-cooled units shall have a coaxial counterflow heat exchanger.

2. Condenser:

- a. Blower shall be of the forward-curved, centrifugal or belt drive type.
- b. Motor shall have permanently lubricated bearings.

D. Compressor:

1. Fully hermetic scroll type.
2. Mounted on suitable spring vibration isolators.
3. Equipped with internal line break protection.

E. Coils:

Evaporator and condenser coils shall be of non-ferrous construction with aluminum fins mechanically bonded to seamless copper tubes with all joints brazed.

F. Refrigerant Components:

Refrigerant components shall include:

1. Thermostatic expansion device tube feed system.
2. Refrigerant filter drier.

G. Filter Section:

Filter section shall consist of factory-installed, permanent, cleanable air filter, removable from the same side as the access panels without the use of tools.

H. Controls and Safeties:

Control system shall include a high-pressure switch, a low-pressure switch, and a compressor lockout feature which upon tripping of any safety device shall prevent compressor from restarting until reset at the thermostat.

I. Operating Characteristics:

1. Unit shall operate using R-410A refrigerant.
2. Unit shall be designed for indoor suspended horizontal mounting and operation.



J. Electrical Requirements:

1. Unit shall have dual electrical control boxes.
2. Unit shall have single point power connection to leads in terminal box.

K. Special Features:

Certain standard features are not applicable when the features designated by * are specified. For assistance in amending the specifications, your local Carrier Sales Office should be contacted.

1. Airside Economizer:
 - a. Shall function as first stage of cooling when free cooling is available. Economizer coil valve can be modulated to control discharge-air temperature when the economizer can meet or exceed cooling needs.
 - b. Consists of the economizer coil, two 3-way valves, vent and drain fittings and the required piping. Economizer coils are 4 or 8 row coils with 8 or 10 fins per inch and are chemically cleanable. The unit controller controls all required control logic and changeover.
2. Hot Gas Bypass:

Shall be factory-installed for extended capacity operation and to prevent coil freezing at low load conditions.
3. Hot Gas Reheat:

Shall be factory-installed to use hot refrigerant gas to reheat the air. Shall be controlled by space humidity levels and only operate when needed.

4. Freeze Protection Switch:

Switch shall provide evaporator coil protection against freezing.

5. High-Static Motor Upgrade:

High-static motor shall provide additional external static pressure.

6. Flooded Condenser:

A three-way modulating valve and a receiver shall be provided. The valve shall be field-installed in the liquid line after the condenser. The receiver shall be field-installed downstream of the valve. The valve shall limit the flow of liquid refrigerant from the condenser while at the same time regulate the flow of discharge gas around the condenser to the receiver.

7. Externally Mounted Condensate Pump:

Unit shall be equipped with remotely located condensate pump. A field-installed light shall illuminate when reservoir rises above a preset level. Unit shall shut down upon reservoir light illumination.

* 8. Electric Duct Heaters:

- a. Provides encased heater elements that shall be installed in unit supply ductwork.
- b. UL listed.

9. Thermostats:

A complete line of thermostats shall be available to meet any application control requirements.

10. Disconnect:

A disconnect shall be provided to remove power to the unit for servicing or maintenance.

