

50ES Comfort™ 13
Single-Packaged Electric Cooling Units with Puron® (R-410A)
Refrigerant
Single- And Three-Phase Units
1-1/2 to 5 Nominal Tons (Sizes 018-060)

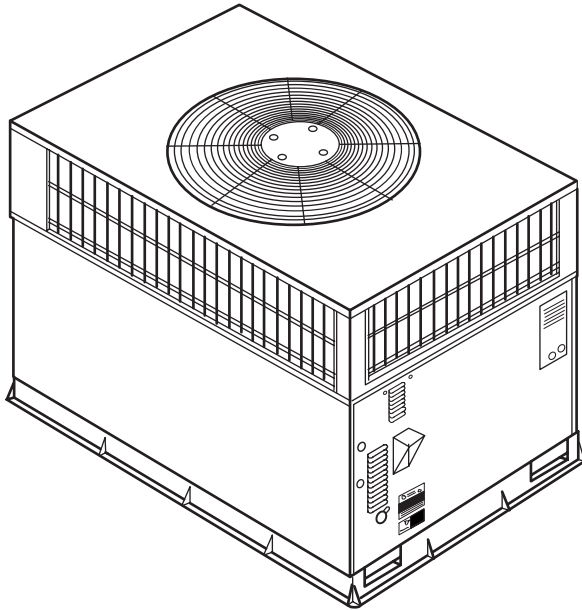

Turn to the Experts.™

Product Data



A99338

Unit 50ES

Single-Packaged Products with Energy-Saving Features and Puron® refrigerant.

- 13 SEER
- Factory-Installed TXV
- Multi-Speed Blower-Standard
- Low Sound Levels

FEATURES/BENEFITS

One-piece cooling unit with optional electric heater, low sound levels, easy installation, low maintenance, and dependable performance.

Puron Environmentally Sound Refrigerant is Carrier's unique refrigerant designed to help protect the environment. Puron is an HFC refrigerant which does not contain chlorine that can harm the ozone layer. The most important advantage of Puron refrigerant is that it has not been banned in future air conditioning systems as the traditional refrigerant R-22 has been. Puron refrigerant is in service in over 100,000 systems proving highly reliable, environmentally sound performance.

Easy Installation

Factory-assembled package is a compact, fully self-contained, electric cooling unit that is prewired, pre-piped, and pre-charged for minimum installation expense. These units are available in a variety of standard cooling sizes with voltage options to meet residential and light commercial requirements. Units are lightweight and install easily on a rooftop or at ground level. The high tech composite base eliminates rust problems associated with ground level applications.

Convertible duct configuration

Unit is designed for easy use in either downflow or horizontal applications. Each unit is easily converted from horizontal to downflow.

Efficient operation High-efficiency design offers SEER (Seasonal Energy Efficiency Ratios) of 13.0.

Durable, dependable components

Scroll Compressors are designed for high efficiency. Each compressor is hermetically sealed against contamination to help promote longer life and dependable operation. Each compressor also has vibration isolation to provide quieter operation. All compressors have internal high pressure and overcurrent protection.

Direct-drive multi-speed blower motor is standard on all 50ES models.

Direct-drive PSC condenser-fan motors are designed to help reduce energy consumption and provide for cooling operation down to 40°F (4.4°C) outdoor temperature. Motormaster® II low ambient kit is available as a field-installed accessory.

Thermostat controls

Time Guard® II anti-short cycle protection circuitry. If a non-corporate thermostat without anti-short cycle protection is used the Time Guard II field-installed anti-short cycle kit is recommended.

Thermostatic Expansion Valve - A hard shutoff, balance port TXV maintains a constant superheat at the evaporator exit (cooling cycle) resulting in higher overall system efficiency.

Refrigerant system is designed to provide dependability. Liquid filter driers are used to promote clean, unrestricted operation. Each unit leaves the factory with a full refrigerant charge. Refrigerant service connections make checking operating pressures easier.

High and Low Pressure Switches provide added reliability for the compressor.

Indoor and Outdoor coils are computer-designed for optimum heat transfer and efficiency. The indoor coil is fabricated from cop-

per tube and aluminum fins and is located inside the unit for protection against damage. The outdoor coil is internally mounted on the top tier of the unit. Copper fin coils and pre-coated fin coils are available from the factory by special order. These coils are recommended in applications where aluminum fins are likely to be damaged due to corrosion. They are ideal for seacoast applications.

Low sound ratings ensure a quiet indoor and outdoor environment with sound ratings as low as 72dBA.

Easy to service cabinets provide easy single-panel accessibility to serviceable components during maintenance and installation. The basepan with integrated drain pan provides easy ground level installation with or without a mounting pad. Convenient handholds are provided to manipulate the unit on the jobsite. A nesting feature ensures a positive basepan to roof curb seal when the unit is roof mounted. A convenient 3/4-in. wide perimeter flange makes frame mounting on a rooftop easy.

Standard metal duct covers with insulation come with the unit and cover the horizontal duct openings. These can be left in place if the units are converted to downflow.

Cabinets are constructed of heavyduty, phosphated, zinc-coated prepainted steel capable of withstanding 500 hours in salt spray. Interior surfaces of the evaporator/heat exchanger compartment are insulated with cleanable semi-rigid insulation board, which keeps the conditioned air from being affected by the outdoor ambient temperature and provides improved indoor air quality. (Conforms to American Society of Heating, Refrigeration and Air Conditioning Engineers No. 62P.) The sloped drain pan minimizes standing water in the drain. An external drain is provided.

Downflow operation is easily provided in the field to allow vertical ductwork connections. The basepan utilizes knockout style seals on the bottom openings to ensure a positive seal in the horizontal airflow mode.

TABLE OF CONTENTS

Features/Benefits	1–2
Model Number Nomenclature	3
ARI Capacities	3–4
Physical Data	5
Options and Accessories	6
Base Unit Dimensions	8–9
Accessory Dimensions	10
Selection Procedure	11
Performance Data	12–16
Typical Piping and Wiring	17
Application Data	18
Electrical Data	19–20
Typical Wiring Schematics	21–23
Controls	24
Guide Specifications	25–26

MODEL NUMBER NOMENCLATURE

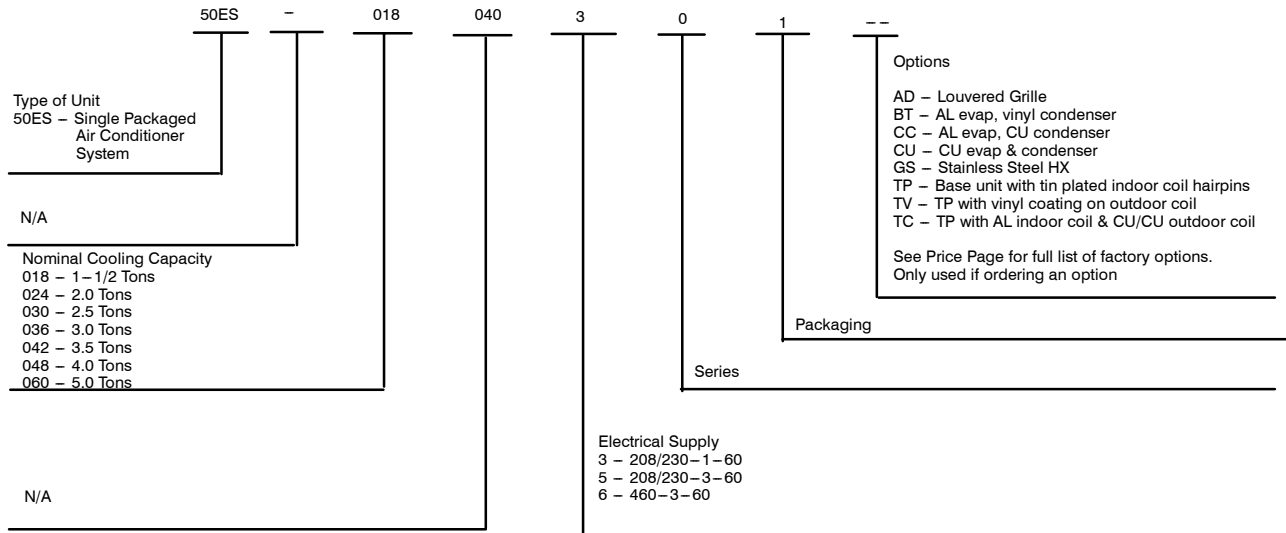

LEGEND
AL – Aluminum
CU – Copper

ISO 9001:2000



50ES

ARI* CAPACITIES

COOLING CAPACITIES AND EFFICIENCIES

UNIT 50ES	NOMINAL TONS	STANDARD CFM	NET COOLING CAPACITIES (Btuh)	EER**	SEER†
018	1-1/2	650	18,000	10.7	13.0
024	2	800	23,000	11.2	13.2
030	2-1/2	1000	28,000	11.2	13.2
036	3	1200	34,000	11.2	13.5
042	3-1/2	1400	40,000	10.9	13.0
048	4	1600	46,500	10.9	13.2
060	5	1750	56,500	11.0	13.2

LEGEND

dB—Sound Levels (decibels)

db—Dry Bulb

SEER—Seasonal Energy Efficiency Ratio

wb—Wet Bulb

COP—Coefficient of Performance

* Air Conditioning & Refrigeration Institute.

**At "A" conditions—80°F (26.7°C) indoor db/67°F (19.4°C) indoor wb & 95°F (35°C) outdoor db.

† Rated in accordance with U.S. Government DOE Department of Energy) test procedures and/or ARI Standards 210/240–94.

Notes:

1. Ratings are net values, reflecting the effects of circulating fan heat.

Ratings are based on:

Cooling Standard: 80°F (26.7°C) db, 67°Fwb (19.4°C) indoor entering—air temperature and 95°F db (35°C) outdoor entering—air temperature.

2. Before purchasing this appliance, read important energy cost and efficiency information available from your retailer.

OUTDOOR SOUND: OCTAVE BAND DATA-DECIBELS

UNIT	50ES						
	018	024	030	036	042	048	060
Capacity							
Sound Ratings* (dBA)	72	76	73	76	74	79	78
Frequency (Hz)	dB						
125	58.0	61.5	63.0	64.5	61.5	66.5	64.0
250	60.5	65.0	64.5	70.0	65.5	70.5	71.0
500	67.5	71.5	68.5	70.0	68.0	73.0	69.5
1000	66.5	70.5	67.0	70.0	69.0	73.5	72.5
2000	62.5	66.5	64.0	66.5	66.5	69.5	71.0
4000	56.5	61.5	60.0	61.5	61.0	66.0	67.5
8000	48.5	55.0	54.0	53.0	56.5	59.5	60.0

⁸ Tested in accordance with ARI Standard 270–95 (not listed inARI).

PHYSICAL DATA

Physical Data-Unit 50ES

UNIT SIZE	018	024	030	036	042	048	060
NOMINAL CAPACITY (ton)	1-1/2	2	2-1/2	3	3-1/2	4	5
OPERATING WEIGHT (lb.)	250	264	281	299	367	382	412
OPERATING WEIGHT (kg)	113.4	119.7	127.4	135.6	166.4	173.2	186.8
COMPRESSOR	Scroll						
REFRIGERANT (R-410A) Quantity lb.	5.0	6.9	8.0	9.2	8.8	9.0	10.5
REFRIGERANT (R-410A) Quantity kg	2.3	3.1	3.6	4.2	4.0	4.1	4.8
REFRIGERANT METERING DEVICE	TXV						
OUTDOOR COIL							
Rows...Fins/in.	1...21	2...21	2...21	2...21	2...21	2...21	2...21
Face Area (sq. ft.)	10.2	10.2	11.9	13.6	13.6	15.5	19.4
OUTDOOR FAN							
Nominal Cfm	2200	2200	2800	3000	3500	3500	4200
Diameter (in.)	22	22	22	22	22	22	22
Diameter (mm)	558.8	558.8	558.8	558.8	558.8	558.8	558.8
Motor HP (RPM)	1/8 (825)	1/8 (825)	1/8 (825)	1/8 (825)	1/8 (825)	1/4 (1100)	1/4 (1100)
INDOOR COIL							
Rows...Fins/in.	3...17	3...17	3...17	4...17	3...17	3...17	4...17
Face Area (sq. ft.)	3.7	3.7	3.7	3.7	4.7	5.7	5.7
INDOOR BLOWER							
Nominal Airflow (Cfm)	650	800	1000	1200	1400	1600	1750
Size (in.)	10x10	10x10	10x10	10x10	11x10	11x10	11x10
Size (mm.)	254x254	254x254	254x254	254x254	279.4x254	279.4x254	279.4x254
Motor HP (RPM)	1/4 (825)	1/3 (1050)	1/3 (1050)	1/2 (1000)	1/2 (1075)	1/2 (1075)	1.0 (1040)
HIGH-PRESSURE SWITCH (psig) Cut-out Reset (Auto)	650 +/- 15 420 +/- 25						
LOSS-OF-CHARGE / LOW-PRESSURE SWITCH (Liquid Line) (psig) cut-out Reset (auto)	20 +/- 5 45 +/- 10						
RETURN-AIR FILTERS (IN.)*†	20x24x1 508x610x25 (mm)						
Throwaway	24x30x1 610x762x25 (mm)		24x36x1 610x910x25 (mm)				

50ES

*Required filter sizes shown are based on the larger of the ARI (Air Conditioning and Refrigeration Institute) rated cooling airflow or the heating airflow velocity of 300 ft/minute for throwaway type. For permanent filters, follow filter manufacturer's recommendations for filter size based on allowable face velocity. Air filter pressure drop for non-standard filters must not exceed 0.08 in. wc.

† If using accessory filter rack refer to the filter rack installation instructions for correct filter sizes and quantity.

Electric Heat Pressure Drop Tables

Small Cabinet: 018-036

STATIC	CFM											
	500	600	700	800	900	1000	1100	1200	1300	1400	1500	1600
5 kW	0.00	0.00	0.00	0.00	0.00	0.00	0.00	0.00	0.02	0.04	0.06	0.07
10 kW	0.00	0.00	0.00	0.00	0.00	0.02	0.04	0.06	0.07	0.09	0.10	0.11
15 kW	0.00	0.00	0.00	0.02	0.04	0.06	0.08	0.10	0.12	0.14	0.16	0.18
20 kW	0.00	0.00	0.02	0.04	0.06	0.08	0.09	0.11	0.13	0.15	0.17	0.19

Large Cabinet: 042-060

STATIC	CFM														
	1100	1200	1300	1400	1500	1600	1700	1800	1900	2000	2100	2200	2300	2400	2500
5 kW	0.00	0.00	0.00	0.01	0.02	0.03	0.04	0.05	0.06	0.07	0.08	0.09	0.10	0.11	0.12
10 kW	0.00	0.00	0.01	0.02	0.03	0.04	0.05	0.06	0.07	0.08	0.09	0.10	0.11	0.12	0.13
15 kW	0.00	0.02	0.03	0.04	0.05	0.06	0.07	0.08	0.09	0.10	0.11	0.12	0.13	0.14	0.15
20 kW	0.02	0.03	0.04	0.05	0.06	0.07	0.08	0.09	0.10	0.11	0.12	0.13	0.14	0.15	0.16

OPTIONS AND ACCESSORIES

Factory-installed options

Louver grille provides hail and vandalism protection. A wire grille is standard on all models. See model number nomenclature for louver grille options.

Coil options include copper/copper and vinyl-coated construction for refrigerant coils. Units are shipped standard with copper tube/aluminum fin construction. See model number nomenclature for coil options.

Field-installed accessories

Economizer with Solid-State Controls and Barometric Relief Dampers
Manual Air Damper (25% open)
Electric Heaters
Filter Rack
Flat Roof Curbs (8-in. and 14-in.)
Square-to-Round Duct Transition Kit
Thermostats
Crankcase Heater
Compressor Hard Start Kit (for use on single-phase units only)
Rigging Kit
Low Ambient Kit (Motormaster® II Control)
Solid-State Time Guard® II Device

Economizer with solid-state controls and barometric relief dampers includes filter racks and provide outdoor air during cooling and reduce compressor operation.

Manual outside air damper includes hood and filter rack with adjustable damper blade for up to 25% outdoor air.

Flat roof curbs in both 8 in. and 14 in. sizes are available for roof mounted applications.

Electric Heaters

ODS CATALOG ORDERING NO.	NOMINAL CAPACITY (kW)	FUSES	USED WITH SIZES						
			018	024	030	036	042	048	060
ELECTRIC HEATERS (208/230 — SINGLE PHASE — 60 Hz)									
CPHEATER052A00	5.0	0	X	X	X	X	X	X	X
CPHEATER069A00	7.5	0	X	X	X	X	X	X	X
CPHEATER065A00	10.0	0	X	X	X	X	X	X	X
CPHEATER051A00	15.0	4			X	X	X	X	X
CPHEATER053A00	20.0	4					X	X	X
ELECTRIC HEATERS (208/230 — THREE PHASE — 60 Hz)									
CPHEATER055A00	5.0	0			X	X	X	X	X
CPHEATER056A00	10.0	0			X	X	X	X	X
CPHEATER057A00	15.0	0			X	X	X	X	X
CPHEATER059A00	20.0	6					X	X	X
ELECTRIC HEATERS (460 — THREE PHASE — 60 Hz)									
CPHEATER060A00	5.0	0				X	X	X	X
CPHEATER061A00	10.0	0				X	X	X	X
CPHEATER062A00	15.0	0				X	X	X	X
CPHEATER063A00	20.0	0					X	X	X

NOTE: Electric heaters are rated at 240v and 480v. Refer to Multiplication Factors table for other voltages.

LEGEND

ODS—Order Distribution System

Minimum Airflow for Reliable Electric Heater Operation

UNITSIZE	018	024	030	036	042	048	060
AIRFLOW	700	800	1000	1200	1400	1600	1750

Square-to-round duct transition kit enables 018-048 size units to be fitted to 14 in. round ductwork.

Compressor hard start kit assists compressor start-up by providing additional starting torque on single phase units and prolongs compressor motor life.

Corporate Thermostats provide control for the system heating and cooling functions. Thermostat models are available in both programmable and non-programmable versions.

Crankcase heater provides anti-floodback protection for low-load cooling applications.

Rigging kit includes lifting brackets which are inserted into the unit base rigging holds to lift unit for rooftop applications.

Low-ambient kit (Motormaster II control) allows the use of mechanical cooling down to outdoor temperatures as low as 0°F (-17°C) when properly installed.

Solid-state Time Guard II device provides short-cycling protection for the compressor. Not required with corporate electronic thermostats.

Filter rack features easy installation, serviceability, and high-filtering performance for vertical applications.

Electric heaters provide additional heat in the unit when required. Each package has a heater module that slides into the controls compartment. Heater sizes range from 5.0 to 20.0 kW. The electric heater design allows the use of a single-point power supply for the entire unit, resulting in lower installed costs.

50ES

ECONOMIZER

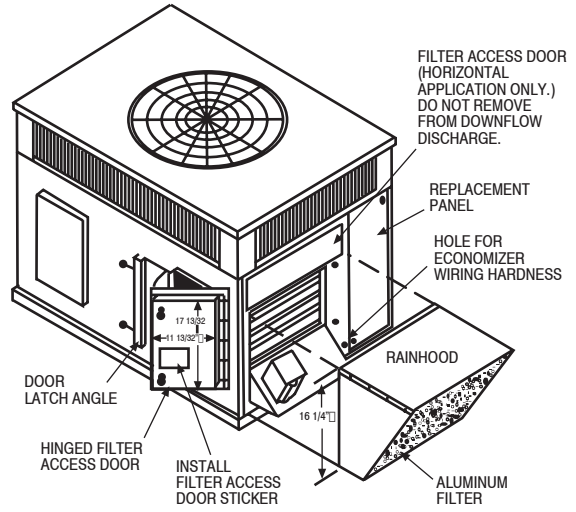
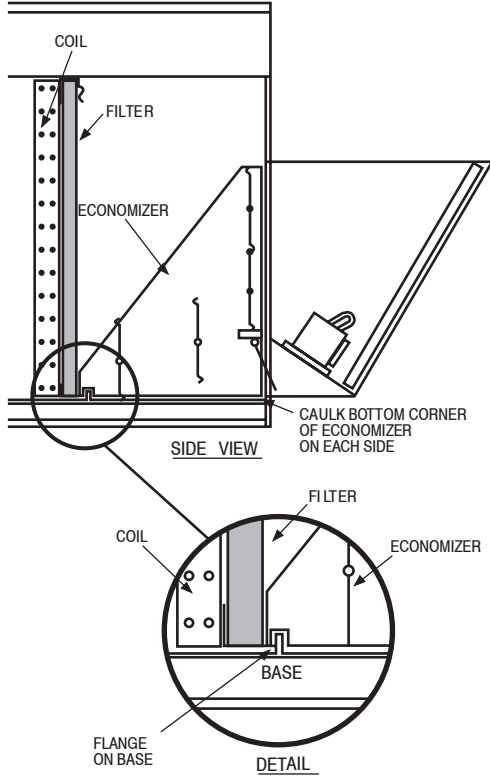

50ES

FILTER RACK

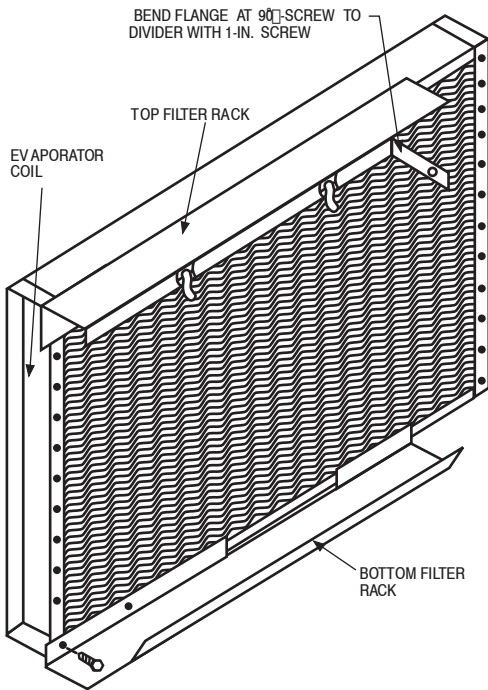

MANUAL OUTSIDE AIR DAMPER

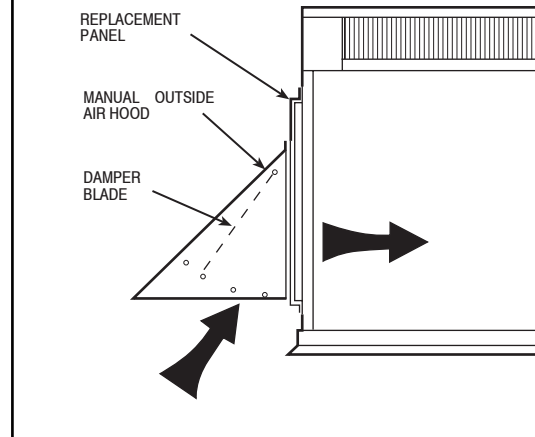

A05239

UNIT DIMENSIONS - 50ES018-036

DIMENSIONS IN [] ARE IN INCHES

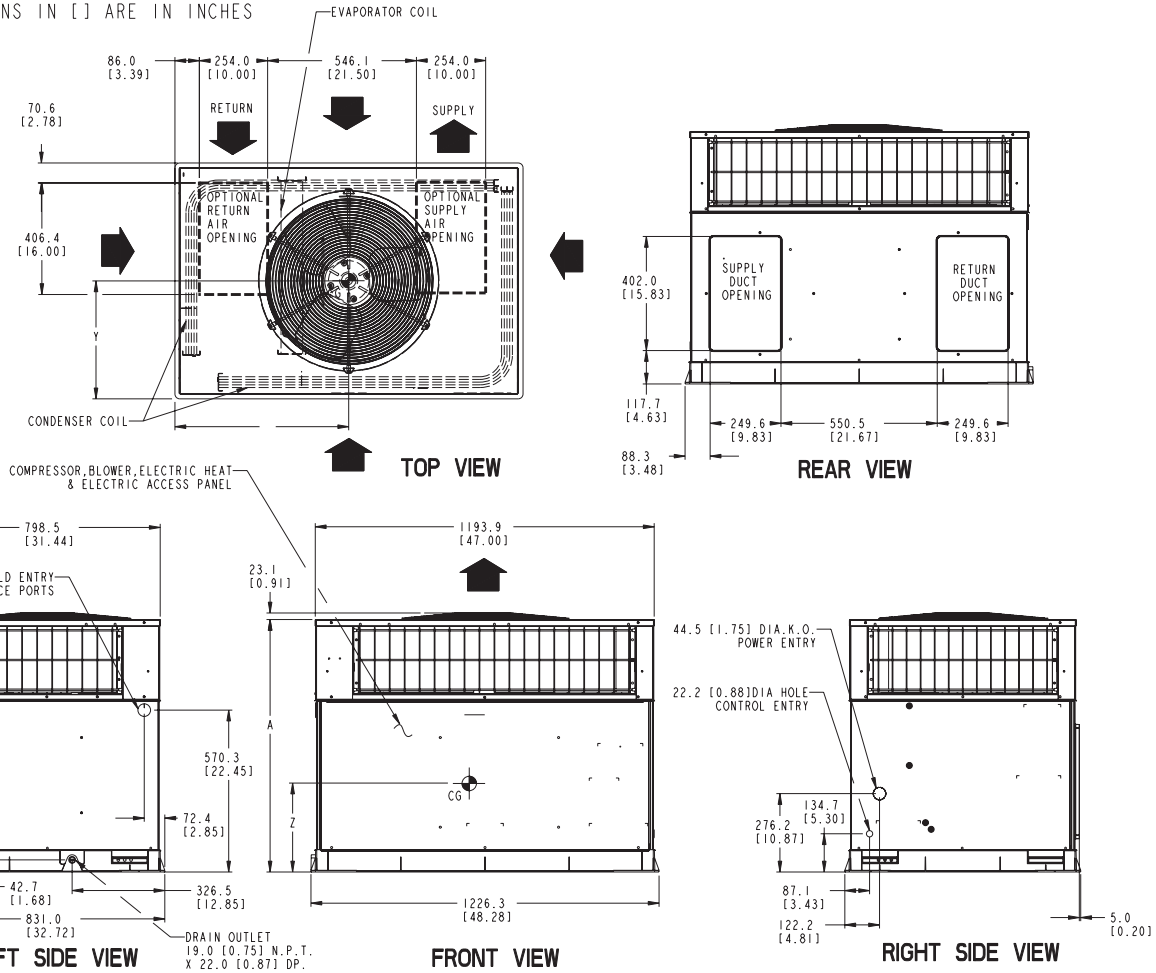

50ES

REQUIRED CLEARANCE TO COMBUSTIBLE MATL (Refer to Maximum Operating Clearances)

	INCHES [mm]
TOP OF UNIT.....	14.00 [355.6]
DUCT SIDE OF UNIT.....	2.00 [50.8]
SIDE OPPOSITE DUCTS.....	14.00 [355.6]
BOTTOM OF UNIT.....	0.50 [12.7]

REQUIRED CLEARANCE FOR OPERATION AND SERVICING

	INCHES [mm]
EVAP. COIL ACCESS SIDE.....	36.00 [914.0]
POWER ENTRY SIDE.....	42.00 [1066.8]
(EXCEPT FOR NEC REQUIREMENTS)	
UNIT TOP.....	48.00 [1219.2]
SIDE OPPOSITE DUCTS.....	36.00 [914.0]
DUCT PANEL.....	12.00 [304.8] *

NEC. REQUIRED CLEARANCES.

	INCHES [mm]
BETWEEN UNITS, POWER ENTRY SIDE.....	42.00 [1066.8]
UNIT AND UNGROUNDED SURFACES, POWER ENTRY SIDE.....	36.00 [914.0]
UNIT AND BLOCK OR CONCRETE WALLS AND OTHER GROUNDED SURFACES, POWER ENTRY SIDE.....	42.00 [1066.8]

*MINIMUM DISTANCES: IF UNIT IS PLACED LESS THAN 304.8 [12.00] FROM WALL SYSTEM, THEN SYSTEM PERFORMANCE MAYBE COMPROMISE.

A05162

UNIT	ELECTRICAL CHARACTERISTICS	UNIT WEIGHT		UNIT HEIGHT IN. [MM] "A"	CENTER OF GRAVITY IN. [MM]		
		lb	kg		X	Y	Z
50ES018	208/230-1-60	250	113.4	37.02 [940]	23.1 [586.7]	14.2 [360.7]	15.5 [393.7]
50ES024	208/230-1-60	264	119.7	37.02 [940]	24.0 [609.6]	16.3 [414.0]	15.7 [398.8]
50ES030	208/230-1-60, 208/230-3-60	281	127.4	39.02 [991]	23.3 [591.8]	15.7 [398.8]	15.8 [401.3]
50ES036	208/230-1-60, 208/230-3-60, 460-3-60	299	135.6	42.98 [1092]	22.6 [574.0]	15.8 [401.3]	16.6 [421.6]

UNIT DIMENSIONS - 50ES042-060

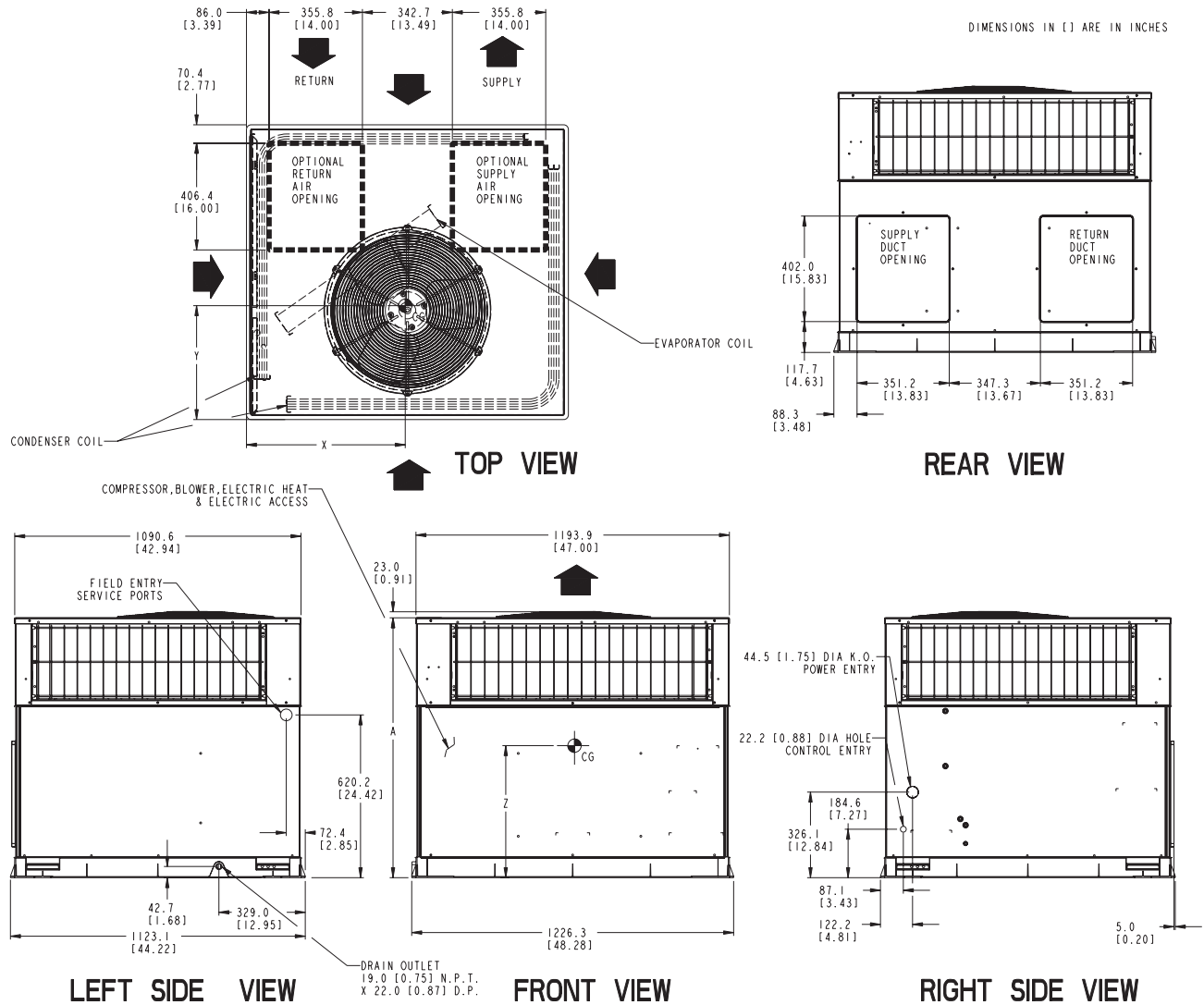

50ES

REQUIRED CLEARANCE TO COMBUSTIBLE MATL (Refer to Maximum Operating Clearances)

	INCHES	[mm]
TOP OF UNIT	14.00	[355.6]
DUCT SIDE OF UNIT	2.00	[50.8]
SIDE OPPOSITE DUCTS	14.00	[355.6]
BOTTOM OF UNIT	0.50	[12.7]

NEC. REQUIRED CLEARANCES.

	INCHES	[mm]
BETWEEN UNITS, POWER ENTRY SIDE	42.00	[1066.8]
UNIT AND UNGROUNDED SURFACES, POWER ENTRY SIDE	36.00	[914.0]
UNIT AND BLOCK OR CONCRETE WALLS AND OTHER GROUNDED SURFACES, POWER ENTRY SIDE	42.00	[1066.8]

REQUIRED CLEARANCE FOR OPERATION AND SERVICING

	INCHES	[mm]
EVAP. COIL ACCESS SIDE	36.00	[914.0]
POWER ENTRY SIDE (EXCEPT FOR NEC REQUIREMENTS)	42.00	[1066.8]
UNIT TOP	48.00	[1219.2]
SIDE OPPOSITE DUCTS	36.00	[914.0]
DUCT PANEL	12.00	[304.8]

*MINIMUM DISTANCES: IF UNIT IS PLACED LESS THAN 304.8 [12.00] FROM WALL SYSTEM, THEN SYSTEM PERFORMANCE MAYBE COMPROMISE.

A05126

UNIT	ELECTRICAL CHARACTERISTICS	UNIT WEIGHT		UNIT HEIGHT IN. [MM] "A"	CENTER OF GRAVITY IN. [MM]		
		lb	kg		X	Y	Z
50ES042	208/230-1-60, 208/230-3-60, 460-3-60	367	166.4	42.98 [1092]	25.5 [647.7]	15.2 [286.1]	17.1 [434.3]
50ES048	208/230-1-60, 208/230-3-60, 460-3-60	382	173.2	42.98 [1092]	24.9 [632.5]	15.5 [393.7]	17.4 [442.0]
50ES060	208/230-1-60, 208/230-3-60, 460-3-60	412	186.8	46.98 [1193]	25.5 [647.7]	15.5 [393.7]	17.6 [447.0]

ACCESSORY DIMENSIONS

50ES

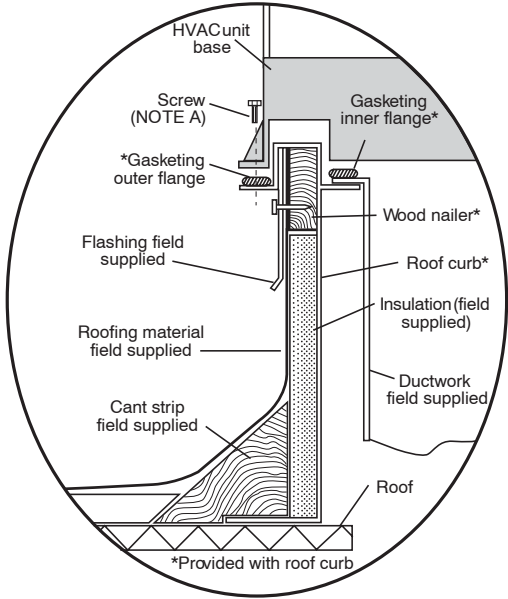

Roof Curb for Small Cabinet

Note A: When unit mounting screw is used, retainer bracket must also be used.

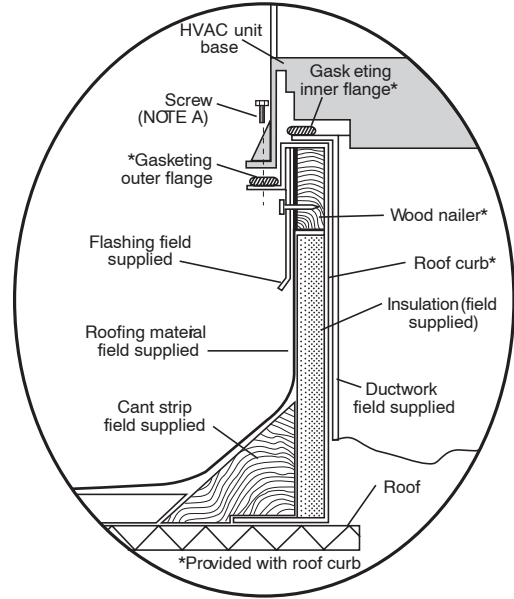

Roof Curb for Large Cabinet

Note A: When unit mounting screw is used, retainer bracket must also be used.

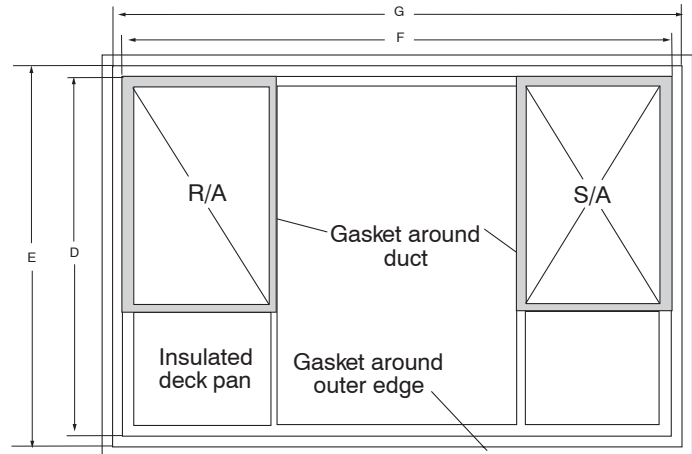
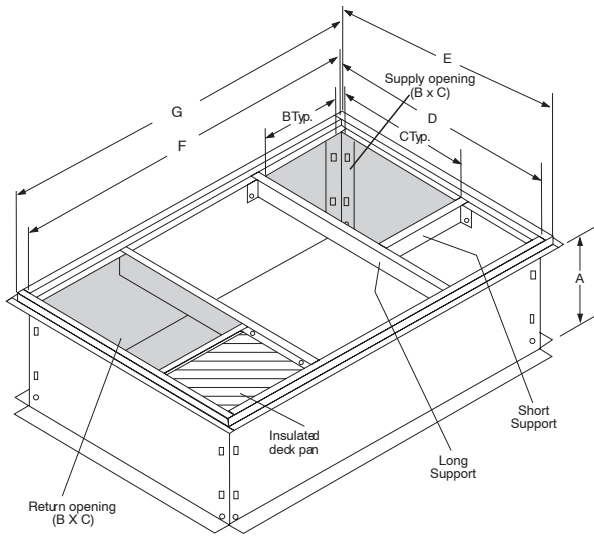

A05308

UNIT SIZE	ODS CATALOG NUMBER	A IN. (MM)	B IN. (MM)	C IN. (MM)	D IN. (MM)	E IN. (MM)	F IN. (MM)	G IN. (MM)
50ES018-036	CPRFCURB006A00	8 (203)	11 (279)	16-1/2 (419)	28-3/4 (730)	30-3/8 (771)	44-5/16 (1126)	45-15/16 (1167)
	CPRFCURB007A00	14 (356)	11 (279)	16-1/2 (419)	28-3/4 (730)	30-3/8 (771)	44-5/16 (1126)	45-15/16 (1167)
50ES042-060	CPRFCURB008A00	8 (203)	16-3/16 (411)	17-3/8 (441)	40-1/4 (1022)	41-15/16 (1065)	44-7/16 (1129)	46-1/16 (1169)
	CPRFCURB009A00	14 (356)	16-3/16 (411)	17-3/8 (441)	40-1/4 (1022)	41-15/16 (1065)	44-7/16 (1129)	46-1/16 (1169)

NOTES:

1. Roof curb must be set up for unit being installed.
2. Seal strip must be applied, as required, to unit being installed.
3. Dimensions are in inches.
4. Roof curb is made of 16-gauge steel.
5. Attach ductwork to curb (flanges of duct rest on curb).
6. Insulated panels: 1-in. thick fiberglass 1 lb. density.
7. When unit mounting screw is used (see Note A), a retainer bracket must be used as well. This bracket must also be used when required by code for hurricane or seismic conditions. This bracket is available through Micrometl.

50ES Unit Corner Weights and Suggested Rigging

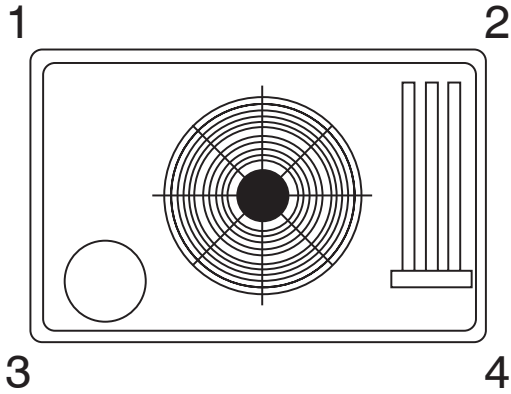

A07216

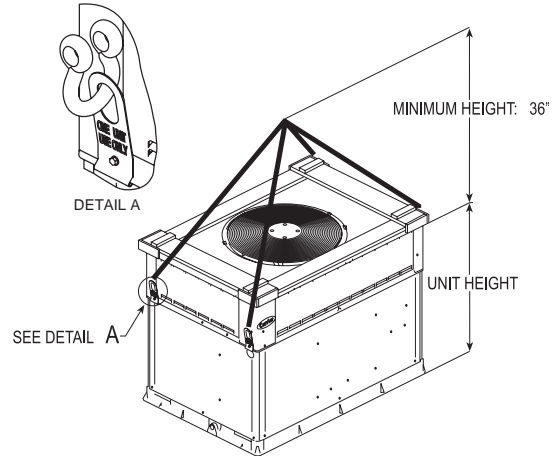

A05161

CORNER WEIGHTS (SMALL CABINET)									CORNER WEIGHTS (LARGE CABINET)						
Unit	018	018	024	024	030	030	036	036	Unit	042	042	048	048	060	060
	lb	kg	lb	kg	lb	kg	lb	kg		lb	kg	lb	kg	lb	kg
Total Weight	250	113.4	264	119.7	281	127.4	299	135.6	Total Weight	367	166.4	382	173.2	412	186.8
Corner Weight 1	30	13.4	53	23.9	50	22.6	62	28.2	Corner Weight 1	62	28.0	40	18.1	22	9.9
Corner Weight 2	79	35.8	75	33.9	85	38.5	82	37.3	Corner Weight 2	109	49.2	141	63.8	174	78.7
Corner Weight 3	58	26.1	72	32.8	70	31.6	78	35.2	Corner Weight 3	113	51.0	84	38.1	75	33.8
Corner Weight 4	84	38.0	64	29.1	77	34.7	77	34.9	Corner Weight 4	84	38.1	117	53.3	142	64.4
Rigging Weight	269	122.0	283	128.3	300	136.1	318	144.2	Rigging Weight	386	175.1	401	181.9	431	195.5
Shipping Weight	304	137.9	318	144.2	335	151.9	353	160.1	Shipping Weight	421	190.9	436	197.7	466	211.3

SELECTION PROCEDURE (WITH EXAMPLE)

1. Determine cooling and heating requirements at design conditions:

Given:

Required Cooling Capacity (TC) 35,000 Btuh
 Sensible Heat Capacity (SHC) 25,000 Btuh
 Required Heating Capacity 12,500 Btuh
 Condenser Entering Air Temperature 95°F(35°C)
 Indoor-Air Temperature 80°F (26°C) edb
 67°F (19°C)ewb
 Evaporator Air Quantity 1200 CFM
 External Static Pressure 0.20 in. wc
 Electrical Characteristics 230-1-60

2. Select unit based on required cooling capacity.

Enter Net Cooling Capacities table at condenser entering temperature of 95°F (35°C), indoor air entering at 1200 cfm and 67°F (19°C) ewb (entering wet bulb). The unit will provide a total capacity of 36,000 Btuh and a SHC of 27,400 Btuh.

3. Select electric heat.

The required heating capacity is 15,000 Btuh.

Determine additional electric heat capacity in kW.

$$\frac{15,000 \text{ Btuh}}{3,414 \text{ Btuh/kW}} = 4.4 \text{ kW of heat required}$$

Enter the electric Heater Packages table for 208/240, single-phase, 50ES036 unit. The 5 kW heater at 240v most closely satisfies the heating required. To calculate kW at the 208v, multiply the heater kW by multiplication factor 0.75 found in the Wattage Multiplication Factors table.

$$5 \text{ kW} \times 0.75 = 3.75 \text{ kW}$$

$$3.75 \text{ kW} \times 3414 = 12802.50 \text{ Btuh}$$

4. Determine fan speed and power requirements at design conditions.

Before entering the air delivery tables, calculate the total static pressure required. From the given example, the Wet Coil Pressure Drop Table, and the Filter Pressure Drop Table:

External Static Pressure	0.200 in. wc
Filter	0.000 in. wc
Wet Coil Pressure Drop	<u>0.130 in. wc</u>
Total Static Pressure	0.330 in. wc

Enter the table for Wet Coil Air Delivery—horizontal discharge, 230. At 0.33 in. wc ESP (external static pressure) and medium speed, the fan will deliver 1293 cfm. Adjusting for 208v, the motor delivers 114 cfm (deduct 10%).

5. Select unit that corresponds to power source available.

The Electrical Data Table shows that the unit is designed to operate at 208-1-60.

PERFORMANCE DATA

50ES018

EVAPORATOR AIR		CONDENSER ENTERING AIR TEMPERATURES deg F (C)																																																																																																																																																																																																																																																																																																																																																																																																																																																																																																																																																																																																																																																																																																																																																																																																																																																																																																																																																																																
CFM / BF	EWB	75 (23.9)				85 (29.4)				95 (35.0)				105 (40.6)				115 (46.1)				125 (51.7)																																																																																																																																																																																																																																																																																																																																																																																																																																																																																																																																																																																																																																																																																																																																																																																																																																																																																																																																																												
		Capacity MBtuh		Total System KW		Capacity MBtuh		Total System KW		Capacity MBtuh		Total System KW		Capacity MBtuh		Total System KW		Capacity MBtuh		Total System KW		Capacity MBtuh		Total System KW																																																																																																																																																																																																																																																																																																																																																																																																																																																																																																																																																																																																																																																																																																																																																																																																																																																																																																																																																										
		Total	Sens	Total	Sens	Total	Sens	Total	Sens	Total	Sens	Total	Sens	Total	Sens	Total	Sens	Total	Sens	Total	Sens	Total	Sens																																																																																																																																																																																																																																																																																																																																																																																																																																																																																																																																																																																																																																																																																																																																																																																																																																																																																																																																																											
525 / 0.003	57	16.99	16.99	1.34	16.32	16.32	1.48	15.62	15.62	1.65	14.87	14.87	1.83	14.06	14.06	2.03	13.18	13.18	2.24	12.24	12.24	2.49	11.28	11.28	2.74	10.31	10.31	3.00	9.38	9.38	3.26	8.41	8.41	3.52	7.44	7.44	3.78	6.40	6.40	4.04	5.36	5.36	4.30	4.30	4.30	4.30																																																																																																																																																																																																																																																																																																																																																																																																																																																																																																																																																																																																																																																																																																																																																																																																																																																																																																																																				
	62	17.60	16.01	1.33	16.77	15.60	1.48	15.89	15.18	1.65	14.97	14.73	1.83	14.06	14.06	2.03	13.18	13.18	2.24	12.24	12.24	2.49	11.28	11.28	2.74	10.31	10.31	3.00	9.38	9.38	3.26	8.41	8.41	3.52	7.44	7.44	3.78	6.40	6.40	4.04	5.36	5.36	4.30	4.30	4.30	4.30																																																																																																																																																																																																																																																																																																																																																																																																																																																																																																																																																																																																																																																																																																																																																																																																																																																																																																																																				
	63	17.97	12.99	1.33	17.12	12.59	1.48	16.22	12.19	1.63	15.28	11.75	1.83	14.25	11.30	2.03	13.16	10.81	2.24	12.24	12.24	2.49	11.28	11.28	2.74	10.31	10.31	3.00	9.38	9.38	3.26	8.41	8.41	3.52	7.44	7.44	3.78	6.40	6.40	4.04	5.36	5.36	4.30	4.30	4.30	4.30																																																																																																																																																																																																																																																																																																																																																																																																																																																																																																																																																																																																																																																																																																																																																																																																																																																																																																																																				
	67	19.35	13.43	1.33	18.45	13.04	1.48	17.51	12.63	1.65	16.49	12.21	1.83	15.41	11.75	2.03	14.25	11.28	2.24	12.24	12.24	2.49	11.28	11.28	2.74	10.31	10.31	3.00	9.38	9.38	3.26	8.41	8.41	3.52	7.44	7.44	3.78	6.40	6.40	4.04	5.36	5.36	4.30	4.30	4.30	4.30																																																																																																																																																																																																																																																																																																																																																																																																																																																																																																																																																																																																																																																																																																																																																																																																																																																																																																																																				
600 / 0.006	57	21.27	10.85	1.33	20.30	10.47	1.48	19.28	10.08	1.64	18.19	9.66	1.83	17.03	9.23	2.02	15.78	8.76	2.24	14.25	14.25	2.49	13.69	13.69	2.96	12.62	12.62	3.26	11.62	11.62	3.52	10.66	10.66	3.78	9.60	9.60	4.04	8.56	8.56	4.30	7.50	7.50	4.56	6.40	6.40	4.82	5.36	5.36	5.08	4.30	4.30	5.30	3.26	3.26	5.56	2.24	2.24	5.82	1.20	1.20	6.08	0.14	0.14	6.34	0.14	0.14	6.60	0.14	0.14	6.86	0.14	0.14	7.12	0.14	0.14	7.38	0.14	0.14	7.64	0.14	0.14	7.90	0.14	0.14	8.16	0.14	0.14	8.42	0.14	0.14	8.68	0.14	0.14	8.94	0.14	0.14	9.20	0.14	0.14	9.46	0.14	0.14	9.72	0.14	0.14	9.98	0.14	0.14	10.24	0.14	0.14	10.50	0.14	0.14	10.76	0.14	0.14	11.02	0.14	0.14	11.28	0.14	0.14	11.54	0.14	0.14	11.80	0.14	0.14	12.06	0.14	0.14	12.32	0.14	0.14	12.58	0.14	0.14	12.84	0.14	0.14	13.10	0.14	0.14	13.36	0.14	0.14	13.62	0.14	0.14	13.88	0.14	0.14	14.14	0.14	0.14	14.40	0.14	0.14	14.66	0.14	0.14	14.92	0.14	0.14	15.18	0.14	0.14	15.44	0.14	0.14	15.70	0.14	0.14	15.96	0.14	0.14	16.22	0.14	0.14	16.48	0.14	0.14	16.74	0.14	0.14	17.00	0.14	0.14	17.26	0.14	0.14	17.52	0.14	0.14	17.78	0.14	0.14	18.04	0.14	0.14	18.30	0.14	0.14	18.56	0.14	0.14	18.82	0.14	0.14	19.08	0.14	0.14	19.34	0.14	0.14	19.60	0.14	0.14	19.86	0.14	0.14	20.12	0.14	0.14	20.38	0.14	0.14	20.64	0.14	0.14	20.90	0.14	0.14	21.16	0.14	0.14	21.42	0.14	0.14	21.68	0.14	0.14	21.94	0.14	0.14	22.20	0.14	0.14	22.46	0.14	0.14	22.72	0.14	0.14	22.98	0.14	0.14	23.24	0.14	0.14	23.50	0.14	0.14	23.76	0.14	0.14	24.02	0.14	0.14	24.28	0.14	0.14	24.54	0.14	0.14	24.80	0.14	0.14	25.06	0.14	0.14	25.32	0.14	0.14	25.58	0.14	0.14	25.84	0.14	0.14	26.10	0.14	0.14	26.36	0.14	0.14	26.62	0.14	0.14	26.88	0.14	0.14	27.14	0.14	0.14	27.40	0.14	0.14	27.66	0.14	0.14	27.92	0.14	0.14	28.18	0.14	0.14	28.44	0.14	0.14	28.70	0.14	0.14	28.96	0.14	0.14	29.22	0.14	0.14	29.48	0.14	0.14	29.74	0.14	0.14	30.00	0.14	0.14	30.26	0.14	0.14	30.52	0.14	0.14	30.78	0.14	0.14	31.04	0.14	0.14	31.30	0.14	0.14	31.56	0.14	0.14	31.82	0.14	0.14	32.08	0.14	0.14	32.34	0.14	0.14	32.60	0.14	0.14	32.86	0.14	0.14	33.12	0.14	0.14	33.38	0.14	0.14	33.64	0.14	0.14	33.90	0.14	0.14	34.16	0.14	0.14	34.42	0.14	0.14	34.68	0.14	0.14	34.94	0.14	0.14	35.20	0.14	0.14	35.46	0.14	0.14	35.72	0.14	0.14	35.98	0.14	0.14	36.24	0.14	0.14	36.50	0.14	0.14	36.76	0.14	0.14	37.02	0.14	0.14	37.28	0.14	0.14	37.54	0.14	0.14	37.80	0.14	0.14	38.06	0.14	0.14	38.32	0.14	0.14	38.58	0.14	0.14	38.84	0.14	0.14	39.10	0.14	0.14	39.36	0.14	0.14	39.62	0.14	0.14	39.88	0.14	0.14	40.14	0.14	0.14	40.40	0.14	0.14	40.66	0.14	0.14	40.92	0.14	0.14	41.18	0.14	0.14	41.44	0.14	0.14	41.70	0.14	0.14	41.96	0.14	0.14	42.22	0.14	0.14	42.48	0.14	0.14	42.74	0.14	0.14	43.00	0.14	0.14	43.26	0.14	0.14	43.52	0.14	0.14	43.78	0.14	0.14	44.04	0.14	0.14	44.30	0.14	0.14	44.56	0.14	0.14	44.82	0.14	0.14	45.08	0.14	0.14	45.34	0.14	0.14	45.60	0.14	0.14	45.86	0.14	0.14	46.12	0.14	0.14	46.38	0.14	0.14	46.64	0.14	0.14	46.90	0.14	0.14	47.16	0.14	0.14	47.42	0.14	0.14	47.68	0.14	0.14	47.94	0.14	0.14	48.20	0.14	0.14	48.46	0.14	0.14	48.72	0.14	0.14	48.98	0.14	0.14	49.24	0.14	0.14	49.50	0.14	0.14	49.76	0.14	0.14	50.02	0.14	0.14	50.28	0.14	0.14	50.54	0.14	0.14	50.80	0.14	0.14	51.06	0.14	0.14	51.32	0.14	0.14	51.58	0.14	0.14	51.84	0.14	0.14	52.10	0.14	0.14	52.36	0.14	0.14	52.62	0.14	0.14	52.88	0.14	0.14	53.14	0.14	0.14	53.40	0.14	0.14	53.66	0.14	0.14	53.92	0.14	0.14	54.18	0.14	0.14	54.44	0.14	0.14	54.70	0.14	0.14	54.96	0.14	0.14	55.22	0.14	0.14	55.48	0.14	0.14	55.74	0.14	0.14	56.00	0.14	0.14	56.26	0.14	0.14	56.52	0.14	0.14	56.78	0.14	0.14	57.04	0.14	0.14	57.30	0.14	0.14	57.56	0.14	0.14	57.82	0.14	0.14	58.08	0.14	0.14	58.34	0.14	0.14	58.60	0.14	0.14	58.86	0.14	0.14	59.12	0.14	0.14	59.38	0.14	0.14	59.64	0.14	0.14	59.90	0.14	0.14	60.16	0.14	0.14	60.42	0.14	0.14	60.68	0.14	0.14	60.94	0.14	0.14	61.20	0.14	0.14	61.46	0.14	0.14	61.72	0.14	0.14	61.98	0.14	0.14	62.24	0.14	0.14	62.50	0.14	0.14	62.76	0.14	0.14	63.02	0.14	0.14	63.28	0.14	0.14	63.54	0.14	0.14	63.80	0.14	0.14	64.06	0.14	0.14	64.32	0.14	0.14	64.58	0.14	0.14	64.84	0.14	0.14	65.10	0.14	0.14	65.36	0.14	0.14	65.62	0.14	0.14	65.88	0.14	0.14	66.14	0.14	0.14	66.40	0.14	0.14	66.66	0.14	0.14	66.92	0.14	0.14	67.18	0.14	0.14	67.44	0.14	0.14	67.70	0.14	0.14	67.96	0.14	0.14	68.22	0.14	0.14	68.48	0.14	0.14	68.74	0.14	0.14	69.00	0.14	0.14	69.26	0.14	0.14	69.52	0.14	0.14	69.78	0.14	0.14	70.04	0.14	0.14	70.30	0.14	0.14	70.56	0.14	0.14	70.82	0.14	0.14	71.08	0.14	0.14	71.34	0.14	0.14	71.60	0.14	0.14	71.86	0.14	0.14	72.12	0.14	0.14	72.38	0.14	0.14	72.64	0.14	0.14	72.90	0.14	0.14	73.16	0.14	0.14	73.42	0.14	0.14	73.68	0.14	0.14	73.94	0.14	0.14	74.20	0.14	0.14	74.46	0.14	0.14	74.72	0.14	0.14	74.98	0.14	0.14	75.24	0.14	0.14	75.50	0.14	0.14	75.76	0.14	0.14	76.02	0.14	0.14	76.28	0.14	0.14	76.54	0.14	0.14	76.80	0.14	0.14	77.06	0.14	0.14	77.32	0.14	0.14	77.58	0.14	0.14	77.84	0.14	0.14	78.10	0.14	0.14	78.36	0.14	0.14	78.62	0.14	0.14	78.88	0.14	0.14	79.14	0.14	0.14	79.40	0.14	0.14	79.66	0.14	0.14	79.92	0.14	0.14	80.18	0.14	0.14	80.44	0.14	0.14	80.70	0.14	0.14	80.96	0.14	0.14	81.22	0.14	0.14	81.48	0.14	0.14	81.74	0.14	0.14	82.00	0.14	0.14	82.26	0.14	0.14	82.52	0.14	0.14	82.78

PERFORMANCE DATA (CONT)

50ES030

EVAPORATOR AIR		CONDENSER ENTERING AIR TEMPERATURES deg F (C)																	
		75 (23.9)			85 (29.4)			95 (35.0)			105 (40.6)			115 (46.1)			125 (51.7)		
		Capacity MBtuh	Total System KW	Sens	Capacity MBtuh	Total System KW	Sens	Capacity MBtuh	Total System KW	Sens	Capacity MBtuh	Total System KW	Sens	Capacity MBtuh	Total System KW	Sens	Capacity MBtuh	Total System KW	Sens
CFM / BF	EWB	Total		Total		Total		Total		Total		Total		Total		Total		Total	
	57	27.63	2.04	26.49	2.25	25.27	2.49	23.94	2.74	22.50	3.01	20.94	3.31	19.41	3.58	17.88	3.85	16.35	4.12
	62	28.17	2.04	26.78	2.25	25.33	2.49	23.94	2.74	22.50	3.01	20.94	3.31	19.41	3.58	17.88	3.85	16.35	4.12
875 / 0.009	63	28.67	2.04	27.24	2.25	25.71	2.49	24.08	2.74	23.34	3.01	21.49	3.31	20.49	3.58	18.45	3.85	17.45	4.12
	67	30.82	2.05	29.28	2.26	27.63	2.49	25.87	2.75	23.99	3.02	21.99	3.32	20.48	3.59	18.45	3.86	17.45	4.13
	72	33.80	2.05	32.10	2.27	30.28	2.50	28.36	2.75	26.28	3.03	24.08	3.32	21.54	3.59	19.41	3.86	17.45	4.13
1000 / 0.013	57	28.69	2.09	27.47	2.31	26.16	2.54	24.74	2.79	23.21	3.07	21.54	3.36	19.41	3.63	17.88	3.90	16.35	3.97
	62	28.77	2.09	27.47	2.31	26.16	2.54	24.74	2.79	23.21	3.07	21.54	3.36	19.41	3.63	17.88	3.90	16.35	3.97
	63	29.16	2.09	27.67	2.31	26.07	2.54	24.38	2.79	22.58	3.07	20.68	3.36	18.45	3.63	16.35	3.90	15.32	3.97
	67	31.33	2.10	29.72	2.31	28.00	2.55	26.18	2.80	24.24	3.07	22.17	3.36	20.68	3.63	18.45	3.90	16.35	3.97
	72	34.34	2.10	32.57	2.32	30.67	2.55	28.68	2.81	26.52	3.08	24.25	3.37	22.17	3.63	20.68	3.90	18.45	3.97
1125 / 0.019	57	29.57	2.15	28.28	2.36	26.88	2.59	25.39	2.85	23.77	3.12	22.01	3.42	20.68	3.69	18.45	3.96	17.45	4.13
	62	29.56	2.15	28.27	2.36	26.88	2.59	25.39	2.85	23.77	3.12	22.01	3.42	20.68	3.69	18.45	3.96	17.45	4.13
	63	29.52	2.15	27.98	2.36	26.34	2.59	24.60	2.85	22.76	3.12	20.82	3.41	19.41	3.69	17.45	3.96	16.35	3.97
	67	31.70	2.15	30.03	2.36	28.26	2.80	26.40	2.85	24.41	3.13	22.30	3.42	20.68	3.69	18.45	3.96	17.45	4.13
	72	34.73	2.16	32.90	2.37	30.94	2.60	28.89	2.86	26.67	3.13	24.34	3.42	22.30	3.69	20.68	3.96	18.45	4.13

50ES036

EVAPORATOR AIR		CONDENSER ENTERING AIR TEMPERATURES deg F (C)																	
		75 (23.9)			85 (29.4)			95 (35.0)			105 (40.6)			115 (46.1)			125 (51.7)		
		Capacity MBtuh	Total System KW	Sens	Capacity MBtuh	Total System KW	Sens	Capacity MBtuh	Total System KW	Sens	Capacity MBtuh	Total System KW	Sens	Capacity MBtuh	Total System KW	Sens	Capacity MBtuh	Total System KW	Sens
CFM / BF	EWB	Total		Total		Total		Total		Total		Total		Total		Total		Total	
	57	32.76	2.31	31.53	2.56	30.22	2.84	28.82	3.15	27.30	3.48	25.63	3.85	24.10	4.12	22.57	4.39	21.11	4.65
	62	33.56	2.31	32.01	2.56	30.39	2.84	28.82	3.15	27.30	3.48	25.63	3.85	24.10	4.12	22.57	4.39	21.11	4.65
1050 / 0.002	63	34.27	2.31	32.67	2.56	30.98	2.84	29.20	3.15	27.28	3.48	25.21	3.85	23.92	4.12	22.11	4.39	20.72	4.65
	67	36.87	2.31	35.16	2.57	33.36	2.85	31.45	3.15	29.40	3.49	27.19	3.85	25.97	4.13	23.92	4.39	22.11	4.65
	72	40.54	2.32	38.69	2.58	36.71	2.85	34.62	3.16	32.38	3.50	29.97	3.86	27.14	4.13	25.97	4.39	24.10	4.65
1200 / 0.004	57	34.22	2.36	32.89	2.62	31.49	2.90	29.98	3.20	28.34	3.54	26.55	3.91	24.10	4.13	22.57	4.39	21.11	4.65
	62	34.37	2.36	32.89	2.62	31.49	2.90	29.98	3.20	28.34	3.54	26.55	3.91	24.10	4.13	22.57	4.39	21.11	4.65
	63	34.97	2.37	33.30	2.62	31.54	2.90	29.68	3.20	27.69	3.54	25.55	3.90	22.57	4.39	21.11	4.65	20.72	4.65
	67	37.61	2.37	35.82	2.62	34.00	2.90	31.94	3.21	29.81	3.54	27.53	3.91	25.55	4.13	23.92	4.39	22.11	4.65
	72	41.33	2.38	39.38	2.63	37.31	2.91	35.13	3.22	32.80	3.55	30.30	3.96	27.30	4.13	25.97	4.39	24.10	4.65
1350 / 0.008	57	35.44	2.42	34.03	2.68	32.53	2.95	30.93	3.26	29.20	3.60	27.30	3.96	24.10	4.13	22.57	4.39	21.11	4.65
	62	35.44	2.42	34.03	2.68	32.53	2.95	30.93	3.26	29.20	3.60	27.30	3.96	24.10	4.13	22.57	4.39	21.11	4.65
	63	35.50	2.42	33.77	2.68	31.95	2.95	30.03	3.26	27.98	3.60	25.80	3.96	23.16	4.13	21.11	4.65	20.72	4.65
	67	38.16	2.43	36.31	2.68	34.36	2.96	32.30	3.27	30.11	3.60	27.77	3.96	24.21	4.13	22.11	4.65	21.11	4.65
	72	41.91	2.44	39.89	2.69	37.74	2.97	35.48	3.27	33.09	3.61	30.51	3.97	27.77	4.13	25.97	4.39	24.10	4.65

50ES

PERFORMANCE DATA (CONT)

50ES042

EVAPORATOR AIR		CONDENSER ENTERING AIR TEMPERATURES deg F (C)																	
		75 (23.9)			85 (29.4)			95 (35.0)			105 (40.6)			115 (46.1)			125 (51.7)		
		CFM / BF	EWB	Total System KW	Capacity MBtuh	Total System KW	Capacity MBtuh	Total System KW	Capacity MBtuh	Total System KW	Capacity MBtuh	Total System KW	Capacity MBtuh	Total System KW	Capacity MBtuh	Total System KW	Capacity MBtuh	Total System KW	
			Total	Sens	Total	Sens	Total	Sens	Total	Sens	Total	Sens	Total	Sens	Total	Sens	Total	Sens	
	57	39.26	39.26	2.88	37.83	37.83	3.20	35.88	35.88	3.55	34.00	34.00	3.94	31.96	31.96	4.35	29.76	29.76	4.80
	62	40.35	36.68	2.89	38.34	35.70	3.21	36.22	34.84	3.56	34.03	33.95	3.94	31.96	31.96	4.35	29.76	29.76	4.80
	63	41.07	29.58	2.90	39.00	28.64	3.22	36.79	27.65	3.56	34.46	26.62	3.94	31.99	25.54	4.35	29.39	24.41	4.79
	67	44.14	30.58	2.93	41.87	29.62	3.24	39.47	28.82	3.59	36.94	27.57	3.97	34.25	26.48	4.37	31.44	25.34	4.81
	72	48.32	24.44	2.96	45.81	23.49	3.28	43.17	22.50	3.83	40.38	21.47	4.00	37.41	20.39	4.41	34.32	19.28	4.84
	57	40.77	40.77	2.97	39.02	39.02	3.29	37.13	37.13	3.64	35.10	35.10	4.02	32.92	32.92	4.44	30.58	30.58	4.88
	62	41.18	39.33	2.98	39.13	38.61	3.29	37.13	37.13	3.64	35.10	35.10	4.02	32.92	32.92	4.44	30.58	30.58	4.88
	63	41.80	31.43	2.98	39.62	30.46	3.30	37.31	29.45	3.64	34.89	28.39	4.02	32.32	27.28	4.43	29.64	26.11	4.87
	67	44.88	32.54	3.01	42.50	31.56	3.32	40.00	30.54	3.67	37.37	29.47	4.05	34.58	28.34	4.45	31.68	27.18	4.89
	72	49.11	25.59	3.05	46.48	24.62	3.36	43.73	23.62	3.71	40.83	22.57	4.08	37.75	21.47	4.49	34.56	20.35	4.92
	57	42.02	42.02	3.06	40.15	40.15	3.38	38.14	38.14	3.73	35.99	35.99	4.11	33.68	33.68	4.52	31.22	31.22	4.96
	62	42.02	42.02	3.06	40.14	40.14	3.38	38.14	38.14	3.73	35.99	35.99	4.11	33.68	33.68	4.52	31.22	31.22	4.96
	63	42.32	33.20	3.06	40.06	32.21	3.38	37.66	31.17	3.72	35.19	30.08	4.10	32.55	28.93	4.51	29.81	27.71	4.95
	67	45.41	34.43	3.09	42.95	33.43	3.40	40.37	32.39	3.75	37.66	31.29	4.12	34.80	30.13	4.53	31.84	28.92	4.97
	72	49.67	26.70	3.13	46.95	25.71	3.44	44.12	24.70	3.79	41.12	23.64	4.16	37.96	22.53	4.56	34.69	21.39	5.00

50ES048

EVAPORATOR AIR		CONDENSER ENTERING AIR TEMPERATURES deg F (C)																	
		75 (23.9)			85 (29.4)			95 (35.0)			105 (40.6)			115 (46.1)			125 (51.7)		
		CFM / BF	EWB	Total System KW	Capacity MBtuh	Total System KW	Capacity MBtuh	Total System KW	Capacity MBtuh	Total System KW	Capacity MBtuh	Total System KW	Capacity MBtuh	Total System KW	Capacity MBtuh	Total System KW	Capacity MBtuh	Total System KW	
			Total	Sens	Total	Sens	Total	Sens	Total	Sens	Total	Sens	Total	Sens	Total	Sens	Total	Sens	
	57	46.24	46.24	3.34	44.25	44.25	3.75	42.10	42.10	4.20	39.79	39.79	4.69	37.27	37.27	5.21	34.57	34.57	5.77
	62	47.38	41.31	3.34	44.96	40.19	3.75	42.39	38.97	4.20	39.78	39.78	4.69	37.27	37.27	5.21	34.57	34.57	5.77
	63	48.22	33.26	3.35	45.72	32.19	3.76	43.06	31.05	4.20	40.24	29.86	4.69	37.23	28.61	5.21	34.06	27.31	5.77
	67	51.54	34.27	3.36	48.83	33.18	3.77	45.97	32.05	4.22	42.91	30.85	4.70	39.67	29.60	5.22	36.28	28.30	5.77
	72	56.08	27.21	3.37	53.10	26.13	3.78	49.97	25.02	4.23	46.62	23.85	4.71	43.09	22.63	5.23	39.41	21.38	5.78
	57	47.90	47.90	3.43	45.77	45.77	3.84	43.47	43.47	4.29	40.98	40.98	4.77	38.30	38.30	5.29	35.44	35.44	5.85
	62	48.26	44.29	3.43	45.60	45.74	3.84	43.46	43.46	4.29	40.98	40.98	4.77	38.30	38.30	5.29	35.44	35.44	5.85
	63	48.98	35.32	3.43	46.37	34.22	3.84	43.61	33.07	4.29	40.67	31.85	4.77	37.96	30.57	5.29	34.30	29.23	5.85
	67	52.30	36.46	3.44	49.48	35.36	3.85	46.50	34.20	4.30	43.33	32.98	4.78	39.99	31.70	5.30	36.50	30.37	5.86
	72	56.88	28.48	3.46	53.77	27.39	3.87	50.52	26.26	4.31	47.05	25.07	4.79	43.40	23.84	5.31	39.62	22.58	5.86
	57	49.26	49.26	3.51	46.99	46.99	3.93	44.56	44.56	4.37	41.93	41.93	4.86	39.11	39.11	5.38	36.11	36.11	5.94
	62	49.26	49.26	3.51	46.99	46.99	3.93	44.56	44.56	4.37	41.93	41.93	4.86	39.11	39.11	5.38	36.11	36.11	5.94
	63	49.52	37.31	3.52	46.82	36.18	3.93	43.98	35.00	4.37	40.96	33.76	4.86	37.78	32.44	5.38	34.46	31.03	5.93
	67	52.84	38.59	3.53	49.92	37.46	3.94	46.86	36.28	4.38	43.60	35.04	4.87	40.18	33.72	5.38	36.63	32.34	5.94
	72	57.43	29.71	3.54	54.22	26.61	3.95	50.88	27.47	4.40	47.31	26.27	4.88	43.58	25.03	5.39	39.71	23.76	5.94

PERFORMANCE DATA (CONT)

50ES060

EVAPORATOR AIR		CONDENSER ENTERING AIR TEMPERATURES deg F (°C)																							
		75 (23.9)				85 (29.4)				95 (35.0)				105 (40.6)				115 (46.1)				125 (51.7)			
CFM / BF	EWB	Capacity MBtuh		Total System KW	Capacity MBtuh		Total System KW	Capacity MBtuh		Total System KW	Capacity MBtuh		Total System KW	Capacity MBtuh		Total System KW	Capacity MBtuh		Total System KW	Capacity MBtuh		Total System KW			
		Total	Sens		Total	Sens		Total	Sens		Total	Sens		Total	Sens		Total	Sens		Total	Sens		Total	Sens	Total
	57	57.18	57.18	4.12	54.74	54.74	4.57	52.17	52.17	5.08	49.44	49.44	5.62	46.49	46.49	6.21	43.26	43.26	6.85	40.26	40.26	7.49	37.03	37.03	
	62	58.24	53.17	4.13	55.28	51.82	4.58	52.26	51.82	5.08	49.44	49.44	5.62	46.49	46.49	6.21	43.26	43.26	6.85	40.26	40.26	7.49	37.03	37.03	
1750 / 0.010	63	59.21	43.22	4.14	56.15	41.90	4.59	52.95	40.53	5.08	49.60	39.12	5.62	46.07	37.65	6.21	42.28	36.10	6.84	42.28	36.10	7.49	37.38	37.38	
	67	63.23	44.50	4.18	59.93	43.17	4.63	56.50	41.81	5.13	52.90	40.40	5.67	48.09	38.93	6.25	45.01	37.38	6.87	45.01	37.38	7.49	37.38	37.38	
	72	68.86	35.81	4.24	65.24	34.48	4.69	61.48	31.73	5.19	57.53	31.73	5.72	53.35	30.27	6.30	48.86	28.73	6.92	48.86	28.73	7.49	37.38	37.38	
2000 / 0.016	57	59.38	59.38	4.25	56.75	56.75	4.70	53.98	53.98	5.21	51.04	51.04	5.75	47.89	47.89	6.34	44.43	44.43	6.97	44.43	44.43	7.49	37.38	37.38	
	62	59.48	57.25	4.25	56.75	56.75	4.70	53.98	53.98	5.21	51.04	51.04	5.75	47.89	47.89	6.34	44.43	44.43	6.97	44.43	44.43	7.49	37.38	37.38	
	63	60.17	46.05	4.25	56.97	44.70	4.70	53.64	43.31	5.20	50.17	41.87	5.74	46.52	40.37	6.32	42.63	38.78	6.95	46.52	40.37	7.49	37.38	37.38	
	67	64.20	47.51	4.29	60.76	46.16	4.75	57.19	44.78	5.24	53.46	43.34	5.78	49.53	41.85	6.36	45.33	40.26	6.98	49.53	41.85	7.49	37.38	37.38	
	72	69.84	37.64	4.35	66.07	36.31	4.81	62.17	34.94	5.30	58.07	33.52	5.84	53.75	32.04	6.41	49.12	30.48	7.03	53.75	32.04	7.49	37.38	37.38	
2250 / 0.022	57	61.17	61.17	4.37	58.37	58.37	4.83	55.44	55.44	5.33	52.32	52.32	5.88	48.98	48.98	6.46	45.33	45.33	7.09	48.98	48.98	7.49	37.38	37.38	
	62	61.16	61.16	4.37	58.37	58.37	4.83	55.44	55.44	5.33	52.32	52.32	5.88	48.98	48.98	6.46	45.33	45.33	7.09	48.98	48.98	7.49	37.38	37.38	
	63	60.89	48.82	4.37	57.57	47.44	4.82	54.15	46.02	5.31	50.59	44.55	5.85	46.85	43.00	6.43	42.92	41.27	7.06	46.85	43.00	7.49	37.38	37.38	
	67	64.91	50.45	4.41	61.36	49.08	4.86	57.69	47.87	5.36	53.86	46.21	5.89	49.84	44.67	6.47	45.58	43.00	7.09	49.84	44.67	7.49	37.38	37.38	
	72	70.53	39.43	4.47	66.85	38.07	4.92	62.63	36.69	5.42	58.41	35.26	5.95	53.97	33.76	6.52	49.23	32.19	7.14	53.97	33.76	7.49	37.38	37.38	

LEGEND

- BF — Bypass Factor
- edb — Entering Dry-Bulb
- Ewb — Entering Wet-Bulb
- KW — Total Unit Power Input
- SHC — Sensible Heat Capacity (1000 Btuh)
- TC — Total Capacity (1000 Btuh) (net)
- rh — Relative Humidity

COOLING NOTES:

1. Ratings are net; they account for the effects of the evaporator – fan motor power and heat.
2. Direct interpolation is permissible. Do not extrapolate.
3. The following formulas may be used:

$$t_{db} = t_{edb} - \frac{\text{Sensible capacity (Btuh)}}{1.10 \times \text{cfm}}$$

$$t_{wb} = \text{Wet-bulb temperature corresponding to enthalpy air leaving evaporator coil (} h_{lwb} \text{)}$$

Where: h_{wb} = Enthalpy of air entering evaporator coil

4. The SHC is based on 80° F (26.6°C) edb temperature of air entering evaporator coil. Below 80° F (26.6°C) edb, subtract (corr factor x cfm) from SHC.

Above 80° F (26.6°C) edb, add (corr factor x cfm) to SHC.

Correction Factor = $1.10 \times (1 + BF) \times (edb + 80)$.

5. Integrated capacity is maximum (instantaneous) capacity less the effect of frost on the outdoor coil and the heat required to defrost it.

PERFORMANCE DATA (CONT)

Dry Coil Air Delivery* — Horizontal Discharge

(Deduct 10% for 208-Volt Operation)

Unit	Motor Speed	External Static Pressure (in. wc)									
		0.1	0.2	0.3	0.4	0.5	0.6	0.7	0.8	0.9	
50ES-018	Low ¹	Watts	260	243	229	217	209	-----	-----	-----	-----
		CFM	859	775	667	536	382	-----	-----	-----	-----
	High	Watts	340	328	317	307	300	294	-----	-----	-----
50ES-024	Low ¹	Watts	311	309	304	301	286	290	286	280	-----
		CFM	935	885	820	757	686	583	423	263	-----
	Medium	Watts	411	405	398	390	379	357	357	345	327
		CFM	1195	1155	1100	1028	957	868	769	647	365
	High	Watts	528	518	509	492	477	467	447	435	421
		CFM	1484	1421	1368	1279	1185	1088	970	853	712
50ES-030	Low	Watts	311	309	304	301	286	290	286	280	-----
		CFM	935	885	820	757	686	583	423	263	-----
	Medium ¹	Watts	411	405	398	390	379	357	357	345	327
		CFM	1195	1155	1100	1028	957	868	769	647	365
	High	Watts	528	518	509	492	477	467	447	435	421
		CFM	1484	1421	1368	1279	1185	1088	970	853	712
50ES-036	Low ¹	Watts	439	429	415	401	395	380	356	339	329
		CFM	1242	1170	1089	994	917	837	702	570	442
	Medium	Watts	503	491	479	461	450	436	418	404	389
		CFM	1320	1244	1162	1081	1005	897	767	662	541
	High	Watts	641	627	623	609	601	588	571	559	548
		CFM	1362	1288	1205	1119	1033	933	826	714	580
50ES-042	Low ¹	Watts	559	540	522	503	483	464	445	425	406
		CFM	1405	1370	1330	1283	1230	1171	1106	1034	957
	Medium	Watts	665	647	629	609	589	567	545	521	497
		CFM	1593	1552	1505	1452	1394	1330	1260	1184	1102
	High	Watts	815	795	775	754	734	715	695	676	656
		CFM	1764	1710	1652	1591	1525	1456	1383	1306	1225
50ES-048	Low	Watts	627	617	607	584	567	548	528	503	480
		CFM	1550	1530	1493	1461	1414	1361	1320	1250	1177
	Medium ¹	Watts	771	755	734	711	690	665	639	607	572
		CFM	1798	1771	1734	1687	1645	1595	1530	1449	1355
	High	Watts	969	941	908	887	858	827	804	767	748
		CFM	2124	2071	2000	1944	1876	1811	1735	1647	1555
50ES-060	Low	Watts	627	617	607	584	567	548	528	503	480
		CFM	1550	1530	1493	1461	1414	1361	1320	1250	1177
	Medium ¹	Watts	771	755	734	711	690	665	639	607	572
		CFM	1798	1771	1734	1687	1645	1595	1530	1449	1355
	High	Watts	969	941	908	887	858	827	804	767	748
		CFM	2124	2071	2000	1944	1876	1811	1735	1647	1555

*Air delivery values are without air filter and are for dry coil (see Wet Coil Pressure Drop table).

¹Factory-shipped cooling speed

"NA" = Not allowed for heating speed

Note: Deduct field-supplied air filter pressure drop and wet coil pressure drop to obtain external static pressure available for ducting.

50ES Wet Coil Pressure Drop (in. wc)

UNIT SIZE	STANDARD CFM (S.C.F.M.)															
	500	600	700	800	900	1000	1100	1200	1300	1400	1500	1600	1700	1800	1900	2000
018	0.011	0.013	0.018	0.022	-	-	-	-	-	-	-	-	-	-	-	-
024	-	0.030	0.037	0.044	0.053	0.063	-	-	-	-	-	-	-	-	-	-
030	-	-	0.037	0.044	0.053	0.063	0.072	0.081	0.105	-	-	-	-	-	-	-
036	-	-	-	-	0.05	0.061	0.072	0.08	0.09	0.11	-	-	-	-	-	-
042	-	-	-	-	-	0.044	0.051	0.059	0.065	0.072	0.080	0.088	0.095	0.105	-	-
048	-	-	-	-	-	-	-	0.044	0.050	0.053	0.059	0.066	0.072	0.077	0.086	-
060	-	-	-	-	-	-	-	-	-	-	0.079	0.087	0.095	0.102	0.113	0.123

Filter Pressure Drop Table (in. wc)

FILTER SIZE	CFM																		
	500	600	700	800	900	1000	1100	1200	1300	1400	1500	1600	1700	1800	1900	2000	2100	2200	2300
20X20X1	0.05	0.07	0.08	0.1	0.12	0.13	0.14	0.15	—	—	—	—	—	—	—	—	—	—	—
24X30X1	—	—	—	0.04	0.05	0.06	0.07	0.07	0.08	0.09	0.1	—	—	—	—	—	—	—	—
24X36X1	—	—	—	—	—	—	—	0.06	0.07	0.07	0.08	0.09	0.09	0.10	0.11	0.12	0.13	0.14	0.14

Economizer 1-in. Filter Pressure Drop (in. wc)

UNIT50ES	PRESSURE DROP
018-036	0.20
042-060	0.25

Multiplication Factors

HEATER KW RATING	VOLTAGE DISTRIBUTION V/3/60	MULTIPLICATION FACTOR
240	200	0.69
	208	.75
	230	.92
	240	1.00

TYPICAL PIPING AND WIRING

50ES

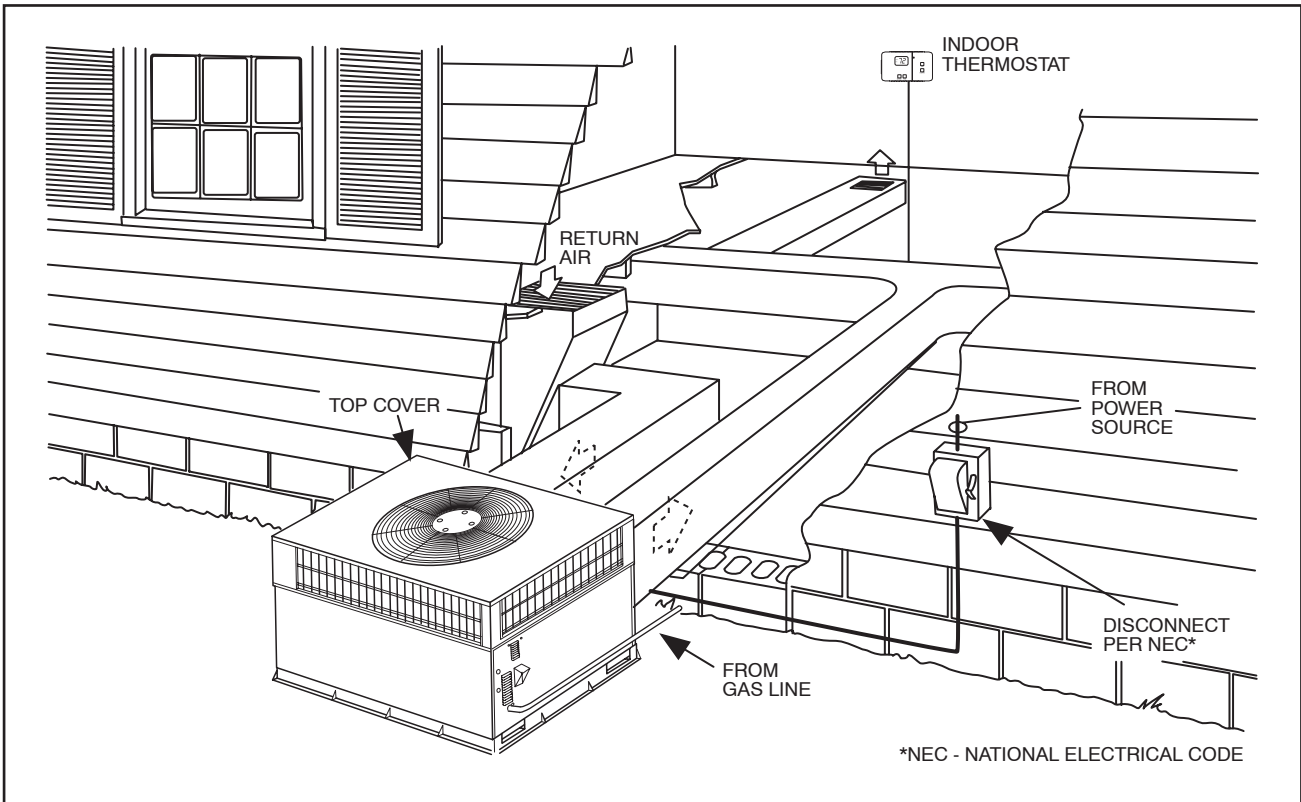
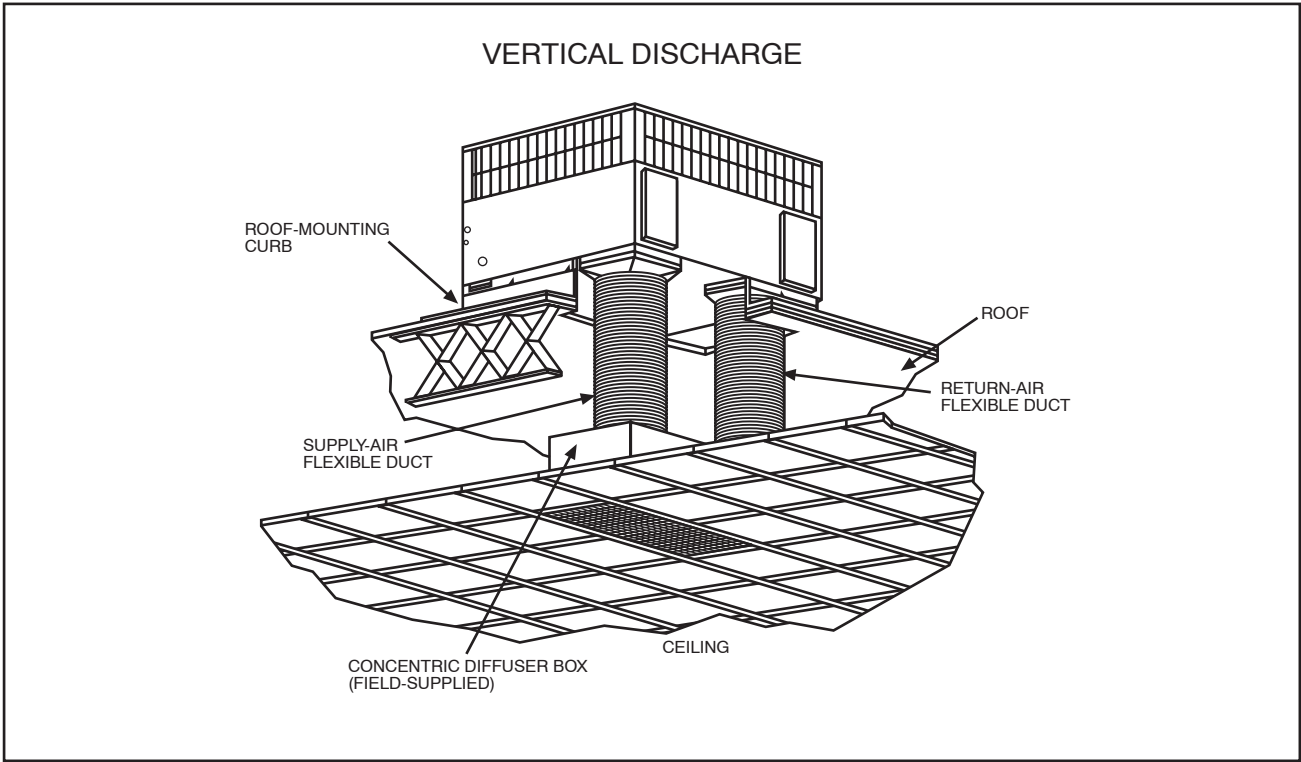

APPLICATION DATA

Condensate trap — A 2-in. condensate trap must be field supplied.

Ductwork — Secure downflow discharge ductwork to roof curb. For horizontal discharge applications, attach ductwork to unit with flanges.

To convert a unit to downflow discharge — Units are equipped with factory-installed inserts in the downflow openings. Removal of the inserts is similar to removing an electrical knock-out.

Maximum cooling airflow — To minimize the possibility of condensate blow-off from the evaporator, airflow through the units should not exceed 450 cfm per ton.

Minimum cooling airflow — Minimum cooling airflow is 350 cfm per ton.

Minimum ambient cooling operation temperature — All standard units have a minimum ambient operating temperature of 40°F (4°C). With accessory low ambient temperature kit, units can operate at temperatures down to 0°F (-17°C).

ELECTRICAL DATA

UNIT	NOMINAL V-PH-HZ	VOLTAGE RANGE		COMPRESSOR		OFM	IFM	ELECTRIC HEAT		POWER SUPPLY	
		MIN	MAX	RLA	LRA	FLA	FLA	NOMINAL	FLA	MCA	MOCP**
								KW*			
50ES-018---3	208/230-1-60	187	253	9.0	48.0	0.9	1.8	-/-	-/-	14.0/14.0	20
								3.8/5	18.1/20.8	24.9/28.3	25/30
								5.4/7.2	25.9/30.0	34.6/39.8	35/40
								7.5/10	36.1/41.7	47.4/54.4	50/60
								-/-	-/-	19.8/19.8	30
50ES-024---3	208/230-1-60	187	253	13.5	58.0	0.9	2.0	3.8/5	18.1/20.8	25.1/28.5	30/30
								5.4/7.2	25.9/30.0	34.9/37.5	35/40
								7.5/10	36.1/41.7	47.6/52.1	50/60
								-/-	-/-	18.9/18.9	30
								3.8/5	18.1/20.8	25.1/28.5	30/30
50ES-030---3	208/230-1-60	187	253	12.8	64.0	0.9	2.0	5.4/7.2	25.9/30.0	34.9/40.0	35/40
								7.5/10	36.1/41.7	47.6/54.6	50/60
								11.3/15	54.2/62.5	70.3/80.6	80/90
								-/-	-/-	15.5/15.5	25
								3.8/5	10.4/12.0	15.5/17.5	25/25
50ES-030---5	208/230-3-60	187	253	10.1	58.0	0.9	2.0	7.5/10	20.8/24.1	28.5/32.6	30/35
								11.3/15	31.3/36.1	41.6/47.6	45/50
								-/-	-/-	22.6/22.6	35
								3.8/5	18.1/20.8	27.8/31.1	35/35
								5.4/7.2	25.9/30.0	37.5/42.6	40/45
50ES-036---3	208/230-1-60	187	253	14.1	77.0	0.9	4.1	7.5/10	36.1/41.7	50.3/57.3	60/60
								11.3/15	54.2/62.5	72.9/83.3	80/90
								-/-	-/-	16.5/16.5	25
								3.8/5	10.4/12.0	18.1/20.1	25/25
								7.5/10	20.8/24.1	31.1/35.3	35/40
50ES-036---5	208/230-3-60	187	253	9.2	71.0	0.9	4.1	11.3/15	31.3/36.1	44.3/50.3	45/50
								-	-	9.5	15
								5	6.0	9.9	15
								10	12.0	17.4	20
								15	18.0	24.9	25
50ES-036---6	460-3-60	414	506	5.6	38.0	0.6	1.9	-/-	-/-	27.4/27.4	40
								3.8/5	18.1/20.8	27.8/31.1	40/40
								5.4/7.2	25.9/30.0	37.5/42.6	40/45
								7.5/10	36.1/41.7	50.3/57.3	60/60
								11.3/15	54.2/62.5	72.9/83.3	80/90
50ES-042---3	208/230-1-60	187	253	17.9	112.0	0.9	4.1	15/20	72.2/83.3	95.4/109.3	100/110
								-/-	-/-	21.9/21.9	30
								3.8/5	10.4/12.0	18.1/20.1	30/30
								7.5/10	20.8/24.1	31.1/35.3	35/40
								11.3/15	31.3/36.1	44.3/50.3	45/50
50ES-042---5	208/230-3-60	187	253	13.5	88.0	0.9	4.1	15/20	41.4/47.9	56.9/65.0	60/70
								-	-	10.0	15
								5	6.0	9.9	15
								10	12.0	17.4	20
								15	18.0	24.9	25
50ES-042---6	460-3-60	414	506	6.0	44.0	0.6	1.9	20	24.1	32.5	35
								-/-	-/-	32.9/32.9	50
								3.8/5	18.1/20.8	27.8/31.1	50/50
								5.4/7.2	25.9/30.0	37.5/42.6	50/50
								7.5/10	36.1/41.7	50.3/57.3	60/60
50ES-048---3	208/230-1-60	187	253	21.8	117.0	1.5	4.1	11.3/15	54.2/62.5	72.9/83.3	80/90
								15/20	72.2/83.3	95.4/109.3	100/110
								-/-	-/-	22.9/22.9	35
								3.8/5	10.4/12.0	18.1/20.1	35/35
								7.5/10	20.8/24.1	31.1/35.3	35/40
50ES-048---5	208/230-3-60	187	253	13.8	83.0	1.5	4.1	11.3/15	31.3/36.1	44.3/50.3	45/50
								15/20	41.4/47.9	56.9/65.0	60/70
								-	-	10.5	15
								5	6.0	9.9	15
								10	12.0	17.4	20
50ES-048---6	460-3-60	414	506	6.2	41.0	0.8	1.9	15	18.0	24.9	25
								20	24.1	32.5	35
								-/-	-/-	40.7/40.7	60
								3.8/5	18.1/20.8	30.4/33.8	60/60
								5.4/7.2	25.9/30.0	40.1/45.3	60/60
50ES-060---3	208/230-1-60	187	253	26.4	134.0	1.5	6.2	7.5/10	36.1/41.7	52.9/59.9	60/60
								11.3/15	54.2/62.5	75.5/85.9	80/90
								15/20	72.2/83.3	98.0/111.9	100/125
								-/-	-/-	29.8/29.8	40
								3.8/5	10.4/12.0	20.8/22.8	40/40
50ES-060---5	208/230-3-60	187	253	17.7	110.0	1.5	6.2	7.5/10	20.8/24.1	33.8/37.9	40/40
								11.3/15	31.3/36.1	46.9/52.9	50/60
								15/20	41.4/47.9	59.5/67.6	60/70
								-	-	13.4	20
								5	6.0	10.9	20
50ES-060---6	460-3-60	414	506	7.8	52.0	0.9	2.7	10	12.0	18.4	20
								15	18.0	25.9	30
								20	24.1	33.5	35
								-	-	13.4	20
								5	6.0	10.9	20

*kW is at 208/240 volts or 480 volts
 **Fuse or HACR type circuit breaker.

50ES

LEGEND

- FLA -- Full Load Amps
- LRA -- Locked Rotor Amps
- MCA -- Minimum Circuit Amps
- MOCP -- Maximum Overcurrent Protection
- RLA -- Rated Load Amps



NOTES:

1. In compliance with NEC (National Electrical Code) requirements for multimotor and combination load equipment (refer to NEC Articles 430 and 440), the overcurrent protective device for the unit shall be Power Supply fuse. The CGA (Canadian Gas Association) units may be fuse or circuit breaker.
2. Minimum wire size is based on 60 C copper wire. If other than 60 C wire is used, or if length exceeds wire length in table, determine size from NEC.
3. Unbalanced 3-Phase Supply Voltage
Never operate a motor where a phase imbalance in supply voltage is greater than 2%. Use the following formula to determine the percentage of voltage imbalance

% Voltage imbalance
 = 100 x $\frac{\text{max voltage deviation from average voltage}}{\text{average voltage}}$

EXAMPLE: Supply voltage is 230-3-60.

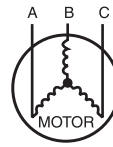

- AB = 228 v
- BC = 231 v
- AC = 227 v

$$\begin{aligned} \text{Average Voltage} &= \frac{228 + 231 + 227}{3} \\ &= \frac{686}{3} \\ &= 229 \end{aligned}$$

Determine maximum deviation from average voltage.

- (AB) 229 - 228 = 1 v
- (BC) 231 - 229 = 2 v
- (AC) 229 - 227 = 2 v

Maximum deviation is 2 v.

Determine percent of voltage imbalance

$$\begin{aligned} \% \text{ Voltage Imbalance} &= 100 \times \frac{2}{229} \\ &= 0.8\% \end{aligned}$$

This amount of phase imbalance is satisfactory as it is below the maximum allowable 2%.

IMPORTANT: If the supply voltage phase imbalance is more than 2%, contact your local electric utility company immediately.

TYPICAL WIRING SCHEMATIC 208/230-1-60

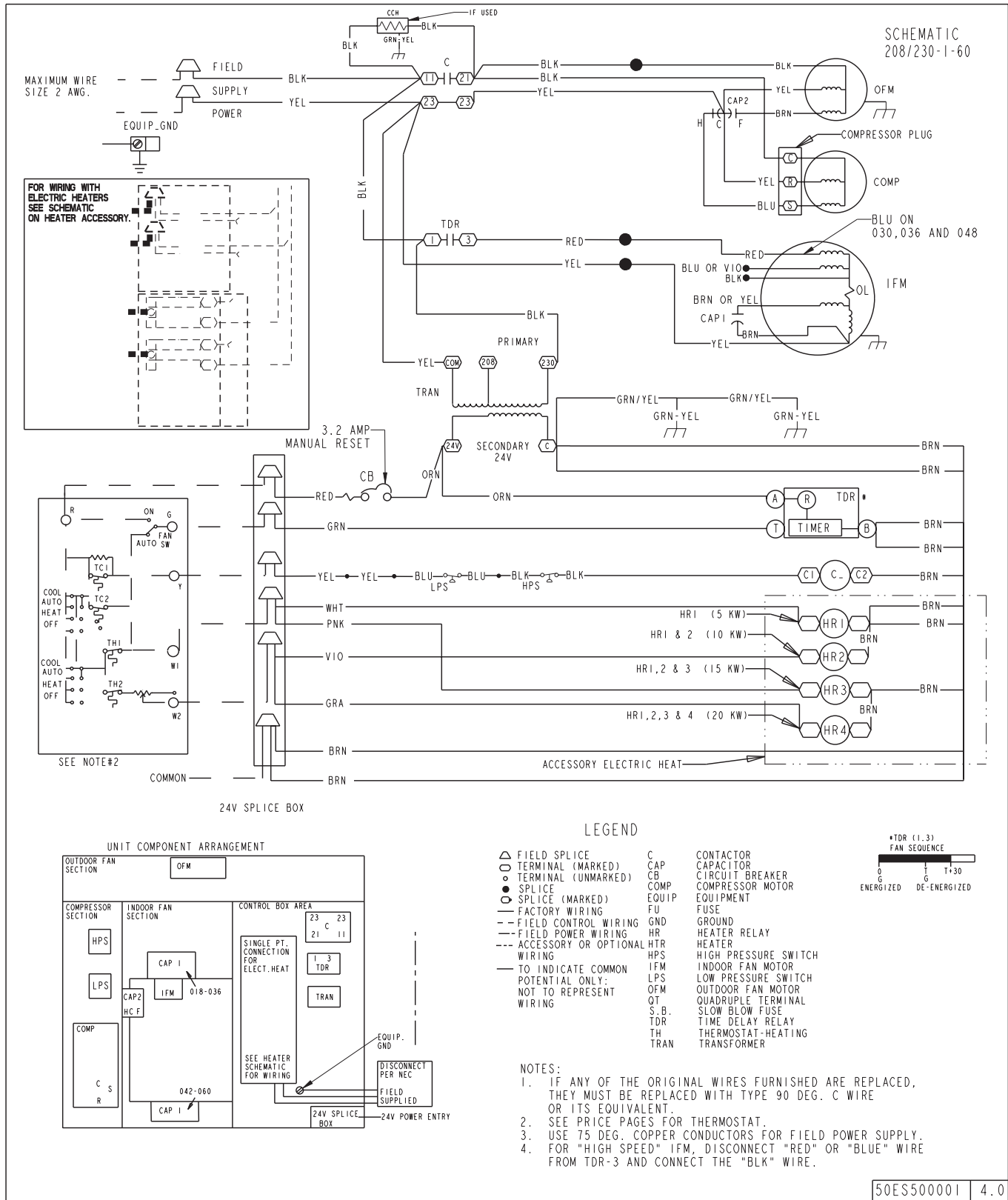

50ES

TYPICAL WIRING SCHEMATIC 208/230-3-60

SCHEMATIC
208/230-3-60

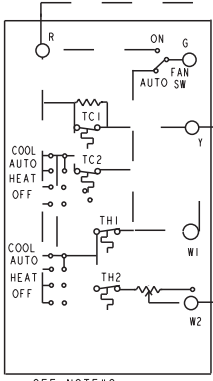
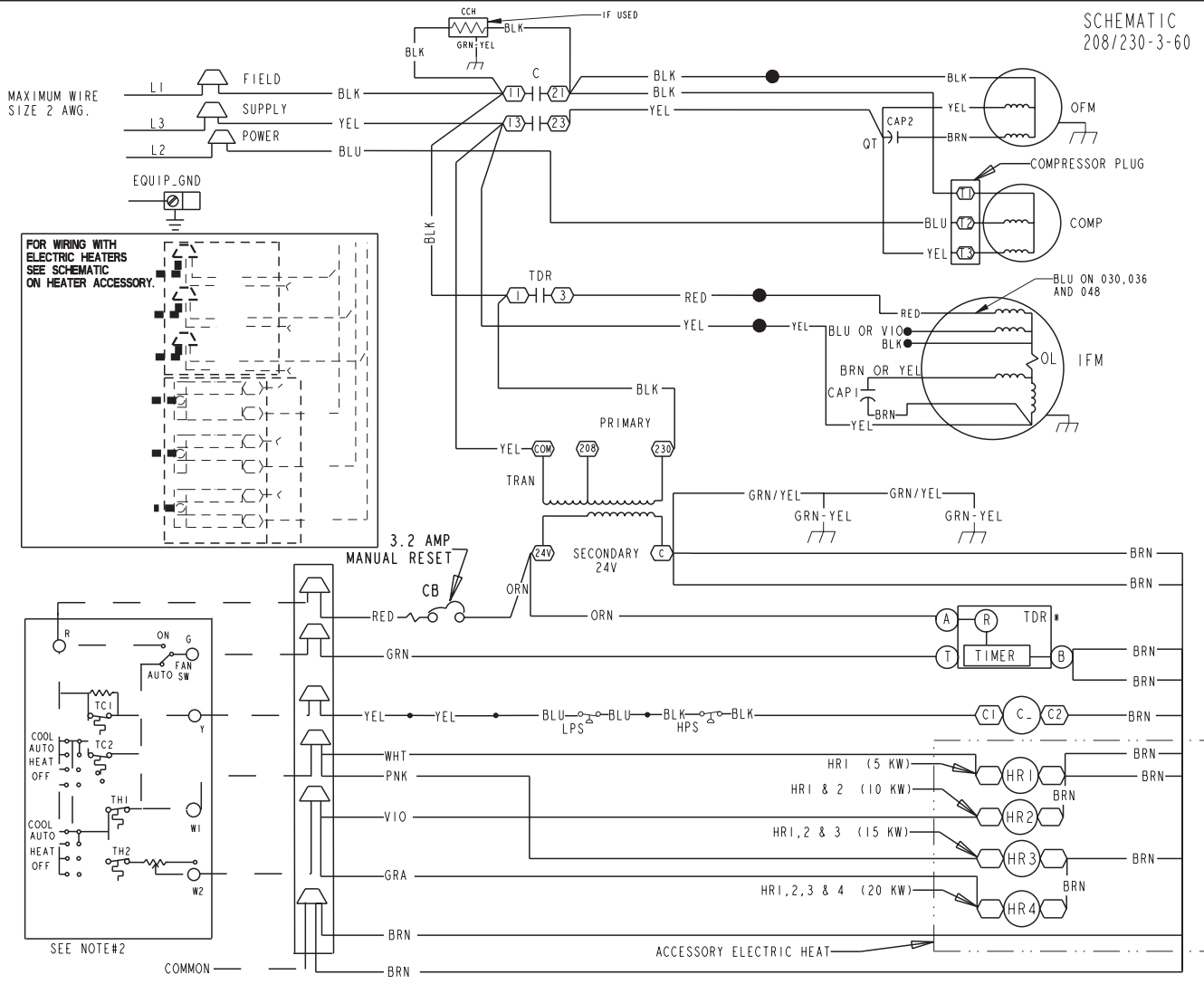

24V SPLICE BOX

UNIT COMPONENT ARRANGEMENT

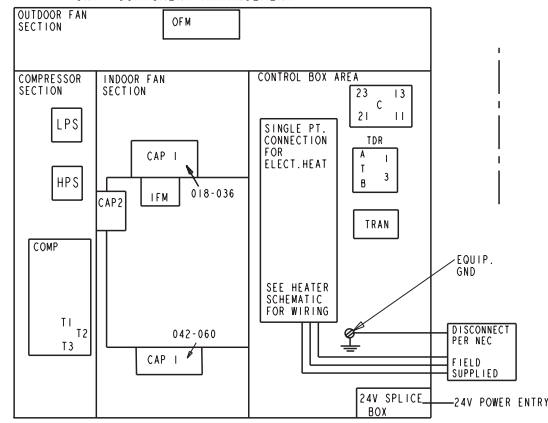

LEGEND

- △ FIELD SPLICE
- TERMINAL (MARKED)
- TERMINAL (UNMARKED)
- SPLICE
- SPLICE (MARKED)
- FACTORY WIRING
- - - FIELD CONTROL WIRING
- - - FIELD POWER WIRING
- - - ACCESSORY OR OPTIONAL WIRING
- TO INDICATE COMMON
- POTENTIAL ONLY: NOT TO REPRESENT WIRING
- C CONTACTOR
- CAP CAPACITOR
- CB CIRCUIT BREAKER
- COMP COMPRESSOR MOTOR
- EQUIP EQUIPMENT
- FU FUSE
- GND GROUND
- HR HEATER RELAY
- HR HEATER
- HTR HIGH PRESSURE SWITCH
- HPS HIGH PRESSURE SWITCH
- IFM INDOOR FAN MOTOR
- LPS LOW PRESSURE SWITCH
- OFM OUTDOOR FAN MOTOR
- QT QUADRUPLE TERMINAL
- TDR TIME DELAY RELAY
- TH THERMOSTAT-HEATING
- TRAN TRANSFORMER

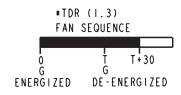

NOTES:

1. IF ANY OF THE ORIGINAL WIRES FURNISHED ARE REPLACED, THEY MUST BE REPLACED WITH TYPE 90 DEG. C WIRE OR ITS EQUIVALENT.
2. SEE PRICE PAGES FOR THERMOSTAT AND SUBBASES.
3. USE 75 DEG. COPPER CONDUCTORS FOR FIELD POWER SUPPLY.
4. FOR "HIGH SPEED" IFM, DISCONNECT "RED" OR "BLUE" WIRE FROM TDR-3 AND CONNECT THE "BLK" WIRE.

50ES500002 4.0

A07234

50ES

TYPICAL WIRING SCHEMATIC 460-3-60

SCHEMATIC
460-3-60

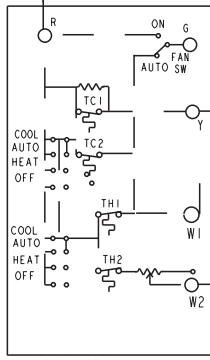
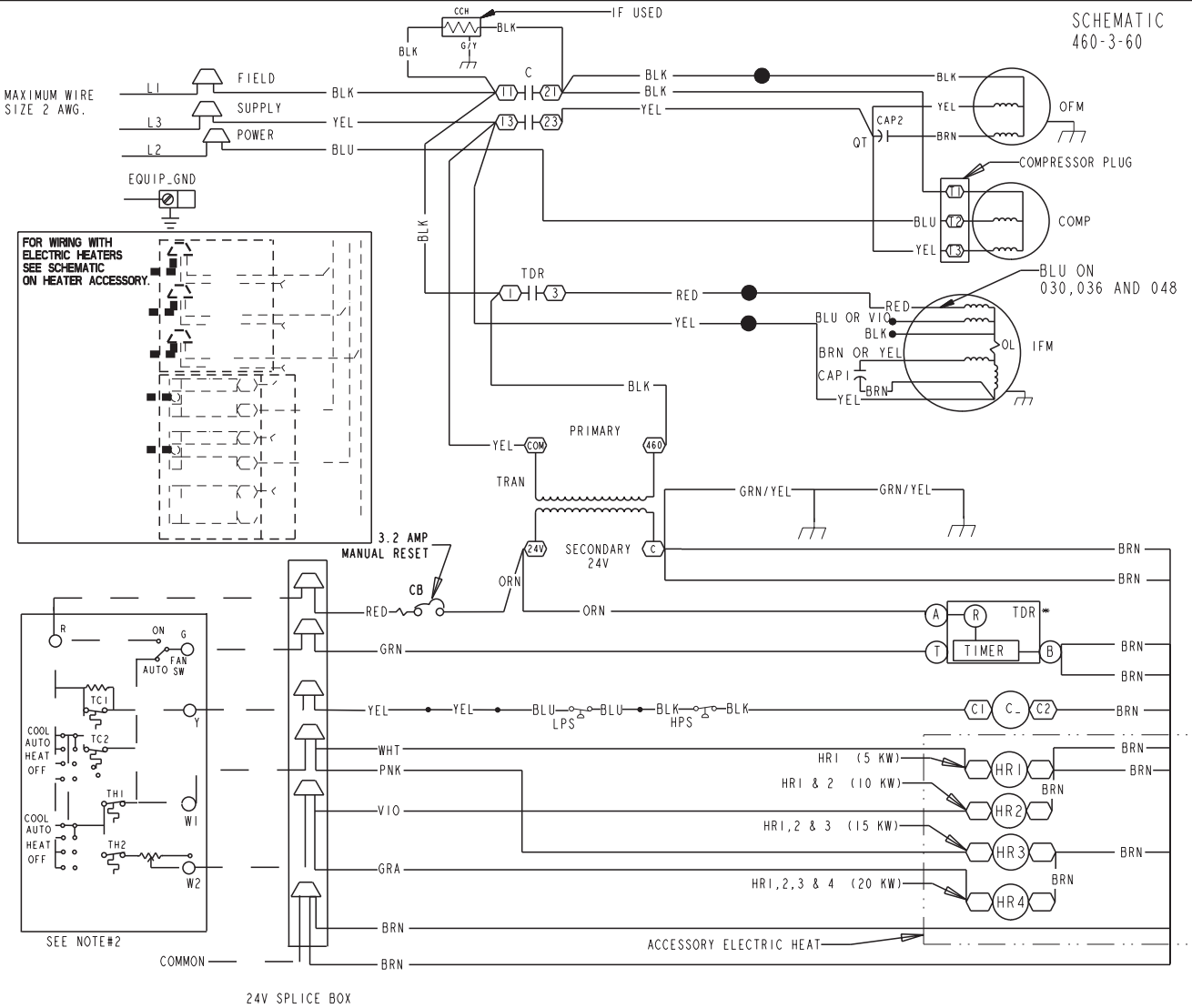

UNIT COMPONENT ARRANGEMENT

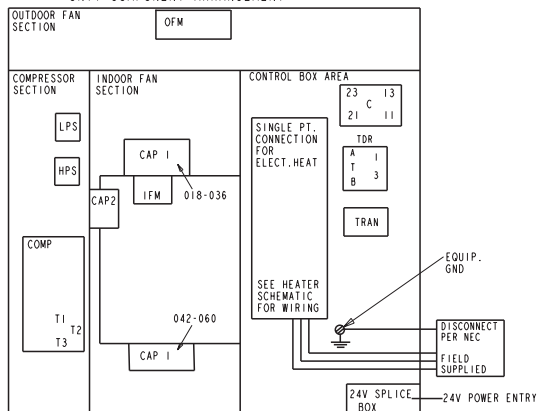

LEGEND

- △ FIELD SPLICE
- TERMINAL (MARKED)
- TERMINAL (UNMARKED)
- SPLICE (MARKED)
- FACTORY WIRING
- - - FIELD CONTROL WIRING
- - - FIELD POWER WIRING
- - - ACCESSORY OR OPTIONAL WIRING
- TO INDICATE COMMON
- POTENTIAL ONLY:
NOT TO REPRESENT WIRING
- C CONTACTOR
- CAP CAPACITOR
- CB CIRCUIT BREAKER
- COMP COMPRESSOR MOTOR
- EQUIP EQUIPMENT
- FU FUSE
- GND GROUND
- HR HEATER RELAY
- HTR HEATER
- LPS LOW PRESSURE SWITCH
- IFM INDOOR FAN MOTOR
- HPS HIGH PRESSURE SWITCH
- OFM OUTDOOR FAN MOTOR
- OT QUADRUPLE TERMINAL
- TDR TIME DELAY RELAY
- TH THERMOSTAT-HEATING TRANSFORMER

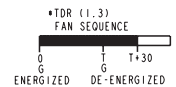

NOTES:

1. IF ANY OF THE ORIGINAL WIRES FURNISHED ARE REPLACED, THEY MUST BE REPLACED WITH TYPE 90 DEG. C WIRE OR ITS EQUIVALENT.
2. SEE PRICE PAGES FOR THERMOSTAT.
3. USE 75 DEG. COPPER CONDUCTORS FOR FIELD POWER SUPPLY.
4. FOR "HIGH SPEED" IFM, DISCONNECT "RED" OR "BLUE" WIRE FROM TDR-3 AND CONNECT THE "BLK" WIRE.

50ES500003 | 4.0

50ES

CONTROLS

Operating sequence

Cooling — When the system thermostat calls for cooling, 24 V is supplied to the “Y” and “G” terminals of the thermostat. This completes the circuit to the contactor coil (C) and indoor (evaporator) fan relay (IFR). The normally open contacts of energized C close and complete the circuit through compressor motor (COMP) to outdoor (condenser) fan motor (OFM). Both motors start instantly. The set of normally open contacts of energized IFR close and complete the circuit through IFM. The IFM starts instantly.

On the loss of the thermostat call for cooling, 24 V is removed from both the “Y” and “G” terminals (provided the fan switch is in the “AUTO” position) de-energizing the compressor contactor and opening the contacts supplying power to compressor/OFM. After a 30-second delay, the IFM shuts off. If the thermostat fan selector switch is in the “ON” position, the IFM will run continuously.

NOTE: On units with a Time Guard[®] II device: Once the compressor has started and then stopped, it cannot be restarted again until 5 minutes have elapsed.

Heating — If accessory electric heaters are installed, on a call for heat, circuit R-W is made through the thermostat contacts. Circuit R-G is made which energizes the IFR. If the heaters are staged, then the thermostat closes a second set of contacts (W2) when second stage is required. When thermostat is satisfied, contacts open, de-energizing the heater relay and the IFR.

GUIDE SPECIFICATIONS

Packaged Electric Cooling Unit Constant Volume Application

HVAC Guide Specifications

Size Range: **1-1/2 to 5 Tons, Nominal Cooling**

Carrier Model Number: 50ES

Part 1 — General

SYSTEM DESCRIPTION

Outdoor rooftop mounted or ground mounted, electric cooling unit utilizing a hermetic scroll compressor for cooling duty. Unit shall discharge supply air vertically or horizontally as shown on contract drawings. Condenser fan/coil section shall have a draw-thru design with vertical discharge for minimum sound levels.

QUALITY ASSURANCE

- A. Unit shall be rated in accordance with ARI Standards 210/240-94 and 270-95.
- B. Unit shall be designed in accordance with UL Standard 1995.
- C. Unit shall be manufactured in a facility registered to ISO 9001 manufacturing quality standard.
- D. Unit shall be UL listed and c-UL certified as a total package for safety requirements.
- E. Roof curb shall be designed to conform to NRCA Standards.
- F. Insulation and adhesives shall meet NFPA 90A requirements for flame spread and smoke generation.
- G. Cabinet insulation shall meet ASHRAE Standard 62P.

DELIVERY, STORAGE AND HANDLING

Unit shall be stored and handled per manufacturer's recommendations.

Part 2 — Products

EQUIPMENT

- A. General:

Factory-assembled, single-piece, heating and cooling unit. Contained within the enclosure shall be all factory wiring, piping, controls, refrigerant charge with R-410A refrigerant, and special features required prior to field start-up.
- B. Unit Cabinet:
 1. Unit cabinet shall be constructed of phosphated, zinc-coated, pre-painted steel capable of with-standing 500 hours in salt spray.
 2. Normal service shall be through a single removable cabinet panel.
 3. The unit shall be constructed on a rust proof unit base that has an externally trapped, integrated sloped drain.
 4. Evaporator fan compartment top surface shall be insulated with a minimum 1/2-in. thick, flexible fiberglass insulation, coated on the air side and retained by adhesive and mechanical means. The evaporator wall sections will be insulated with a minimum semi-rigid foil-faced board capable of being wiped clean. Aluminum foil-faced fiberglass insulation shall be used in the entire indoor air cavity section.
 5. Unit shall have a field-supplied condensate trap.
- C. Fans:
 1. The evaporator fan shall be direct-drive multi-speed motor and control, as shown on equipment drawings.
 2. Fan wheel shall be made from steel, be double-inlet type with forward curved blades with corrosion resistant finish. Fan wheel shall be dynamically balanced.
3. Condenser fan shall be direct drive propeller type with aluminum blades riveted to corrosion resistant steel spiders, be dynamically balanced, and discharge air vertically.
- D. Compressor:
 1. Fully hermetic compressors with factory-installed vibration isolation.
 2. Scroll compressors shall be standard on all units.
- E. Coils:

Evaporator and condenser coils shall have aluminum plate fins mechanically bonded to seamless copper tubes with all joints brazed (Copper/copper and vinyl-coated construction available as option). Tube sheet openings shall be belled to prevent tube wear.
- F. Heating Section:
 1. Induced-draft combustion type with energy saving direct spark ignition system and redundant main gas valve.
 2. Induced-draft motors shall be provided with solid-state hall-effect sensor to ensure adequate airflow for combustion.
 3. The heat exchangers shall be constructed of aluminized steel for corrosion resistance.
 4. Burners shall be of the in-shot type constructed of aluminum coated steel.
 5. All gas piping and electric power shall enter the unit cabinet at a single location.
- G. Refrigerant Components:

Refrigerant expansion device shall be of the TXV (thermostatic expansion valve) type.
- H. Filters:

Filter section shall consist of field-installed, throwaway, 1-in. thick fiberglass filters of commercially available sizes.
- I. Controls and Safeties:
 1. Unit controls shall be complete with a self-contained low voltage control circuit.
 2. Compressors shall incorporate a solid-state compressor protector that provides reset capability.
- J. Operating Characteristics:
 1. Unit shall be capable of starting and running at 125°F (51°C) ambient outdoor temperature per maximum load criteria of ARI Standard 210.
 2. Compressor with standard controls shall be capable of operation down to 40°F (4°C) ambient outdoor temperature.
 3. Units shall be provided with fan time delay to prevent cold air delivery before the heat exchanger warms up.
 4. Unit shall be provided with 30-second fan time delay after the thermostat is satisfied.
- K. Electrical Requirements:

All unit power wiring shall enter the unit cabinet at a single location.
- L. Motors:
 1. Compressor motors shall be of the refrigerant-cooled type with line-break thermal and current overload protection.
 2. All fan motors shall have permanently lubricated bearings, and inherent, automatic reset, thermal overload protection.
 3. Condenser fan motor shall be totally enclosed.

GUIDE SPECIFICATIONS (CONT)

M. Special Features:

1. Louvered Grille:
Wire grille shall be standard on all units. Louvered grille shall be available as a factory-installed option to provide hail guard and vandalism protection.
2. Coil Options:
Shall include factory-installed optional copper/copper and vinyl-coated refrigerant coils.
3. Economizer:
 - a. Economizer controls capable of providing free cooling using outside air.
 - b. Equipped with low leakage dampers not to exceed 3% leakage, at 1.0 in. wc pressure differential.
 - c. Spring return motor shuts off outdoor damper on power failure.
4. Flat Roof Curb:
Curbs shall have seal strip and a wood nailer for flashing and shall be installed per manufacturer's instructions.
5. Manual Outdoor Air Damper:
Package shall consist of damper, birdscreen, and rainhood which can be preset to admit outdoor air for year-round ventilation.
6. Thermostat:
To provide for one-stage heating and cooling in addition manual or automatic changeover and indoor fan control.
7. Low Ambient Package:
Shall consist of a solid-state control and condenser coil temperature sensor for controlling condenser-fan motor operation, which shall allow unit to operate down to 0°F outdoor ambient temperature when properly installed.
8. Filter Rack Kit:
Shall provide filter mounting for downflow applications.
9. Square-To-Round Duct Transitions (018-048):
Shall have the ability to convert the supply and return openings from rectangular to round.
10. Compressor Protection:
Solid-state control shall protect compressor by preventing "short cycling."
11. Crankcase Heater:
Shall provide anti-floodback protection for low-load cooling applications.
12. Electric Heaters:
 - a. Electric heater shall be available as a field-installed option.
 - b. Heater elements shall be open wire type, adequately supported and insulated with ceramic bushings.
 - c. Electric heater packages must provide single point power connection capability.
13. Compressor Hard Start Kit (single phase units only):
Shall provide additional starting torque for single-phase compressors.