



# Installation, Start-Up and Service Instructions

## CONTENTS

	Page
<b>SAFETY CONSIDERATIONS</b> .....	1
<b>GENERAL</b> .....	2
<b>INSTALLATION</b> .....	2-18
<b>Step 1 — Check Jobsite</b> .....	2
<b>Step 2 — Check Unit</b> .....	9
• STORAGE	
• UNIT PROTECTION	
<b>Step 3 — Mounting the Unit</b> .....	9
<b>Step 4 — Electrical Wiring</b> .....	9
• SUPPLY VOLTAGE	
• EXTERNAL LOOP POWER CONNECTION	
• 230-VOLT OPERATION	
<b>Step 5 — Low Voltage Wiring</b> .....	10
• WATER FREEZE PROTECTION	
• ACCESSORY CONNECTIONS	
• WATER SOLENOID VALVES	
• OPTIONAL WALL-MOUNTED THERMOSTAT	
• OPTIONAL PREMIERLINK CONTROLLER	
<b>Step 6 — Supply and Return Piping Installation</b> ...	18
• SUPPLY AND RETURN HOSES	
• SUPPLY AND RETURN PIPING	
<b>Step 7 — Condensate Piping Installation</b> .....	18
<b>PRE-START-UP</b> .....	18-20
<b>System Cleaning and Flushing</b> .....	18
<b>System Checkout</b> .....	19
<b>FIELD SELECTABLE INPUTS</b> .....	20,21
<b>Complete C Control Jumper Settings</b> .....	20
<b>Complete C Control DIP Switches</b> .....	20
<b>Deluxe D Control Jumper Settings</b> .....	20
<b>Deluxe D Control DIP Switches</b> .....	20
<b>Deluxe D Control Accessory</b>	
<b>Relay Configurations</b> .....	21
<b>START-UP</b> .....	21-23
<b>Unit Start-Up/Cooling</b> .....	21
<b>Operating Limits</b> .....	21
<b>Unit Start-Up/Heating</b> .....	22
<b>Flow Regulation</b> .....	22
<b>Antifreeze</b> .....	22
<b>Cooling Tower/Boiler Systems</b> .....	22
<b>Ground Coupled, Closed Loop and Plateframe</b>	
<b>Heat Exchanger Well Systems</b> .....	22
<b>OPERATION</b> .....	23
<b>Power Up Mode</b> .....	23
<b>Units with Aquazone Complete C Control</b> .....	23
<b>Units with Aquazone Deluxe D Control</b> .....	23
<b>SYSTEM TEST</b> .....	23-25
<b>Test Mode</b> .....	24
<b>Retry Mode</b> .....	24
<b>Aquazone Deluxe D Control LED Indicators</b> .....	24
<b>SERVICE</b> .....	26,27
<b>Unit Inspection</b> .....	26
<b>System Flushing</b> .....	26
<b>Water Coil</b> .....	26
<b>Refrigerant System</b> .....	26
<b>Condenser Cleaning</b> .....	26
<b>Condensate Pans</b> .....	27
<b>Blower Motors</b> .....	27

<b>Compressor</b> .....	27
<b>Safety Control Reset</b> .....	27
<b>Checking System Charge</b> .....	27
<b>Refrigerant Charging</b> .....	27
<b>Air Coil Fan Motor Removal</b> .....	27
<b>TROUBLESHOOTING</b> .....	27-29
<b>Thermistor</b> .....	27
<b>START-UP CHECKLIST</b> .....	CL-1, CL-2

**IMPORTANT:** Read the entire instruction manual before starting installation.

## SAFETY CONSIDERATIONS

Installation and servicing of air-conditioning equipment can be hazardous due to system pressure and electrical components. Only trained and qualified service personnel should install, repair, or service air-conditioning equipment.

Untrained personnel can perform basic maintenance functions of cleaning coils and filters and replacing filters. All other operations should be performed by trained service personnel. When working on air-conditioning equipment, observe precautions in the literature, tags and labels attached to the unit, and other safety precautions that may apply.

Improper installation, adjustment, alteration, service, maintenance, or use can cause explosion, fire, electrical shock or other conditions which may cause personal injury or property damage. Consult a qualified installer, service agency, or your distributor or branch for information or assistance. The qualified installer or agency must use factory-authorized kits or accessories when modifying this product. Refer to the individual instructions packaged with the kits or accessories when installing.

Follow all safety codes. Wear safety glasses and work gloves. Use quenching cloth for brazing operations. Have fire extinguisher available. Read these instructions thoroughly and follow all warnings or cautions attached to the unit. Consult local building codes and applicable electrical codes for special installation requirements.

Understand the signal words — DANGER, WARNING, and CAUTION. DANGER identifies the most serious hazards which will result in severe personal injury or death. WARNING signifies hazards that could result in personal injury or death. CAUTION is used to identify unsafe practices, which would result in minor personal injury or product and property damage.

**▲ WARNING**

Electrical shock can cause personal injury or death. Before installing or servicing system, always turn off main power to system. There may be more than one disconnect switch. Turn off accessory heater power if applicable.

## GENERAL

These instructions are for Carrier Console Water Source Heat Pump systems.

Console Water Source Heat Pump units are decentralized room terminals designed for field connection to a closed-circuit piping loop. They are offered in capacities ranging from 7,800 to 16,000 Btuh cooling and 10,400 to 19,300 Btuh heating.

Units are typically installed in perimeter zones, usually under windows. Supply air is discharged directly into the conditioned space through discharge grilles located in the top of the unit.

**IMPORTANT:** The installation of console water source heat pump units and all associated components, parts, and accessories which make up the installation shall be in accordance with the regulations of ALL authorities having jurisdiction and MUST conform to all applicable codes. It is the responsibility of the installing contractor to determine and comply with ALL applicable codes and regulations.

## INSTALLATION

**Step 1 — Check Jobsite** — Units are typically installed along an outside wall of the room. Refer to Fig. 1A and 1B for an illustration showing piping locations. Install units with adequate clearance to allow maintenance and servicing. Refer to Table 1 and Fig. 2-6. Locate the console unit so that it provides adequate air circulation throughout the room.

Installation, operation and maintenance instructions are provided with each unit. Before unit start-up, read all manuals and become familiar with the unit and its operation. Thoroughly check out the system before operation. Complete the inspections and instructions listed below to prepare a unit for installation.

1. Compare the electrical data on the unit nameplate with ordering and shipping information to verify that the correct unit has been shipped.
2. Keep both the chassis and cabinet covered with the shipping carton until all plastering, painting, and finish work is complete and it is time to install the chassis and cabinet.

3. Verify that the refrigerant tubing is free of kinks or dents, and that it does not touch other unit components.
4. Inspect all electrical connections. Connections must be clean and tight at the terminals.

### ⚠ CAUTION

To avoid equipment damage, do not use these units as a source of heating or cooling during the construction process. The mechanical components and filters used in these units quickly become clogged with construction dirt and debris which may cause system damage.

### ⚠ CAUTION

To avoid the release of refrigerant into the atmosphere, the refrigerant circuit of this unit must only be serviced by technicians who meet local, regional, and national proficiency requirements.

### ⚠ CAUTION

All refrigerant discharged from this unit must be recovered without exception. Technicians must follow industry accepted guidelines and all local, regional, and national statutes for the recovery and disposal of refrigerants.

### ⚠ CAUTION

When a compressor is removed from this unit, system refrigerant circuit oil will remain in the compressor. To avoid leakage of compressor oil, the refrigerant lines of the compressor must be sealed after it is removed.

**Table 1 — 50KQL Physical Data**

BASE UNIT 50KQL	07	09	12	15	19
<b>NOMINAL CAPACITY (Btuh)</b>	7,800	9,300	12,300	13,800	16,000
<b>COMPRESSOR</b>	Rotary				
<b>BLOWER</b>					
Motor Horsepower	1/20	1/15	1/15	1/6	1/6
Wheel Size D x W (in.) 2 each	5 1/4 x 6 1/4	5 1/4 x 6 1/4	5 1/4 x 6 1/4	5 1/4 x 6 1/4	5 1/4 x 6 1/4
<b>FILTER SIZE (in.) Bottom Return</b>	8 x 29 1/2 x 3/8	8 x 29 1/2 x 3/8	8 x 29 1/2 x 3/8	8 x 29 1/2 x 3/8	8 x 29 1/2 x 3/8
<b>FILTER SIZE (in.) Front Return</b>	7 x 29 1/2 x 1/8	7 x 29 1/2 x 1/8	7 x 29 1/2 x 1/8	7 x 29 1/2 x 1/8	7 x 29 1/2 x 1/8
<b>UNIT WEIGHT (lb)</b>					
Shipping	181	185	195	201	206
Operating	173	177	187	193	198
<b>REF. TO AIR HEAT EXCHANGER</b>					
Face Area (sq ft)	1.4	1.4	1.4	1.8	1.8
No. of Rows Deep	2	2	3	3	4
Copper Tube Size OD (in.)	3/8	3/8	3/8	3/8	5/16
Fin Spacing (FPI)	13	13	13	13	12
<b>REFRIG. CHARGE (R-22)/CKT (oz)</b>					
No. of Circuits	16 1	16 1	21 1	27 1	24 1
<b>UNIT CABINET WITH STANDARD SUBBASE (3 in.)</b>					
W x H x D (in.)	48 x 24 x 12	48 x 24 x 12	48 x 24 x 12	48 x 24 x 12	48 x 24 x 12
<b>WATER IN/OUT SIZE OD SWEAT (in.)</b>	5/8	5/8	5/8	5/8	5/8
<b>CONDENSATE SIZE ID VINYL (in.)</b>	5/8	5/8	5/8	5/8	5/8



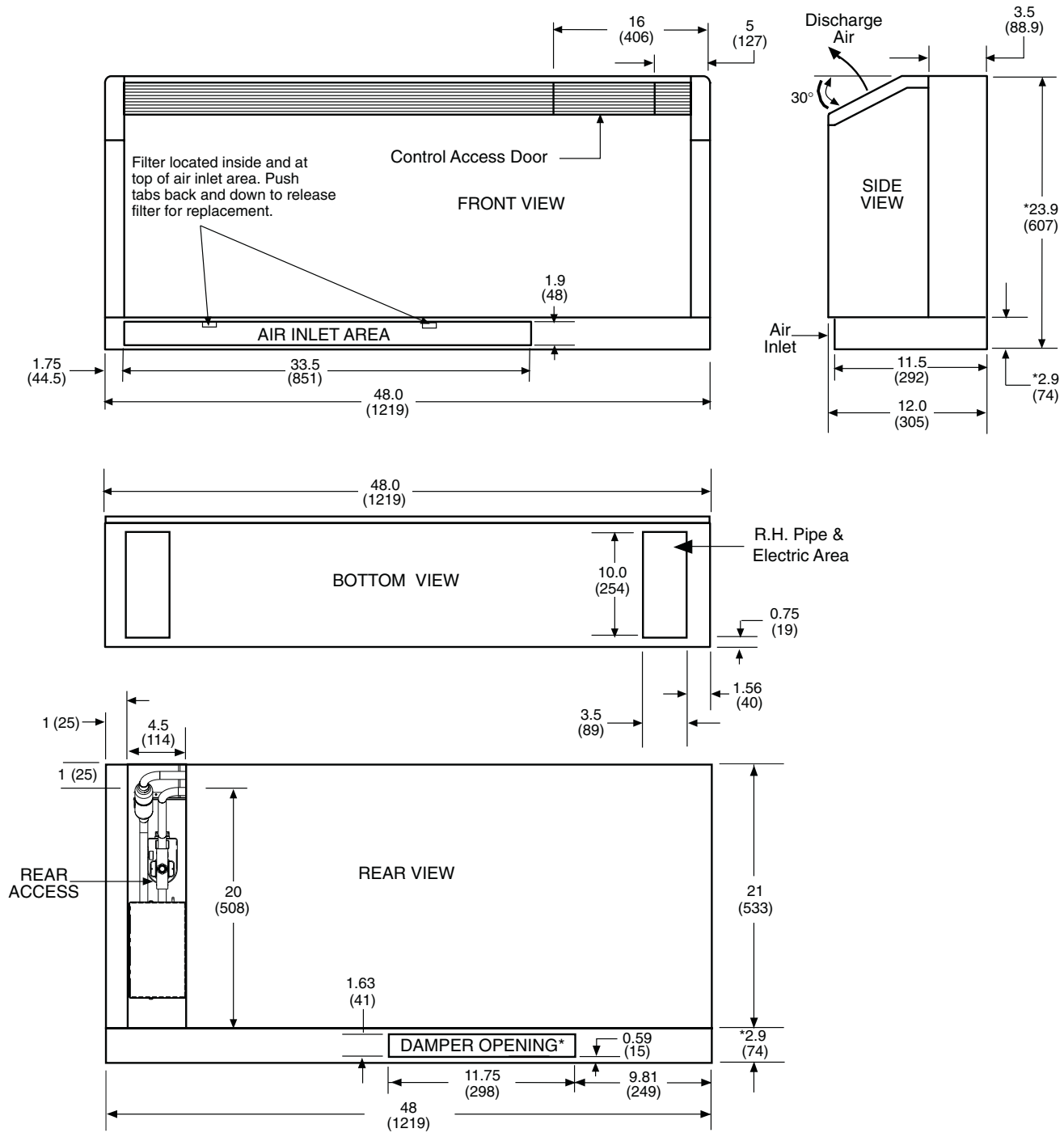

\*Dimension shown is with 3 in. subbase. Add 2 in. to dimension shown for 5 in. subbase.

NOTES:

1. Dimensions are shown in inches. Dimensions in parentheses are in millimeters.
2. Optional autoflow valve, motorized water valve and disconnect box are shown.

**Fig. 2 — 50KQL Bottom Return Cabinet Dimensions — Right-Hand Piping**

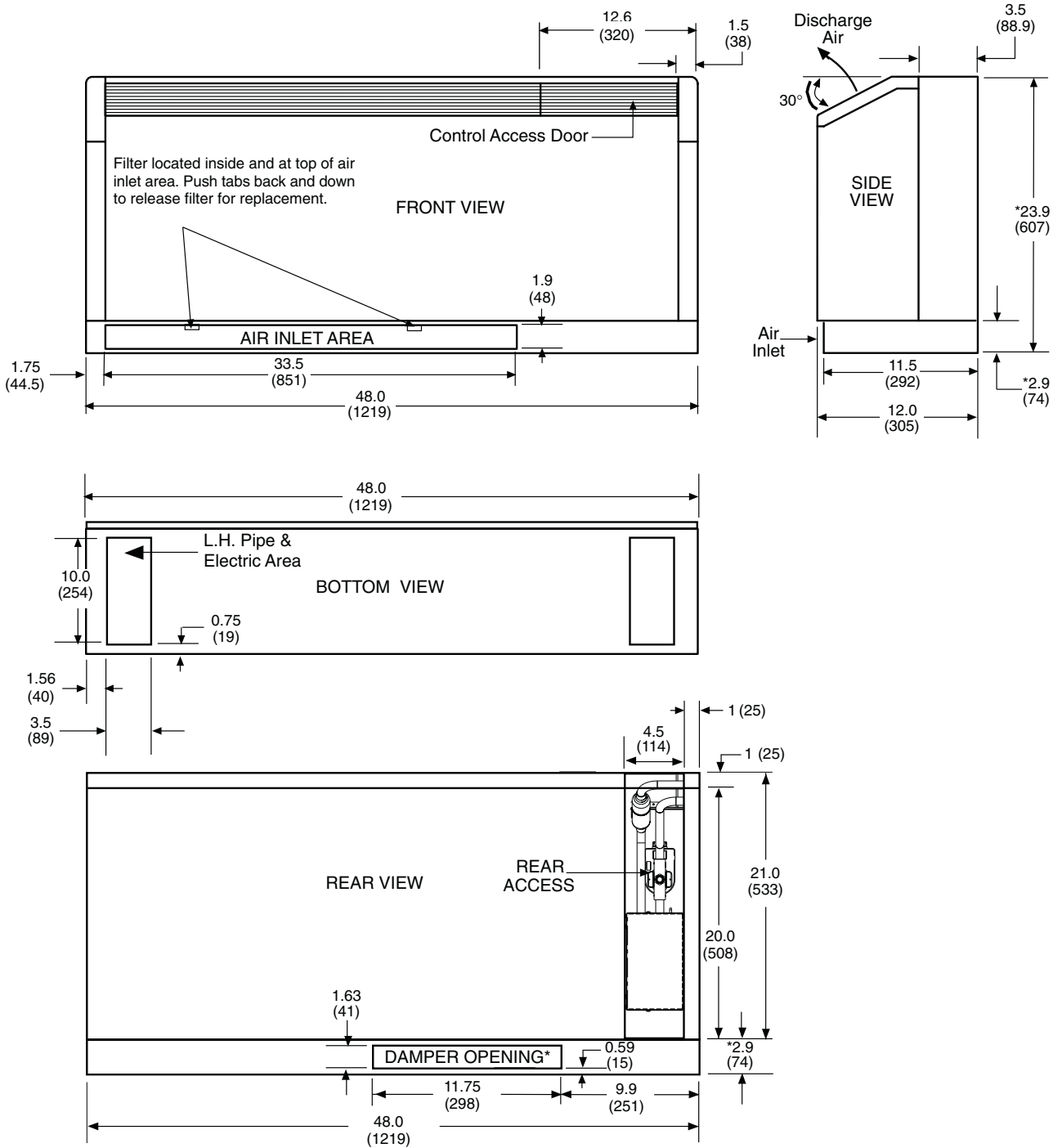

\*Dimension shown is with 3 in. subbase. Add 2 in. to dimension shown for 5 in. subbase.

NOTES:

1. Dimensions are shown in inches. Dimensions in parentheses are in millimeters.
2. Optional autoflow valve, motorized water valve and disconnect box are shown.

**Fig. 3 — 50KQL Bottom Return Cabinet Dimensions — Left-Hand Piping**

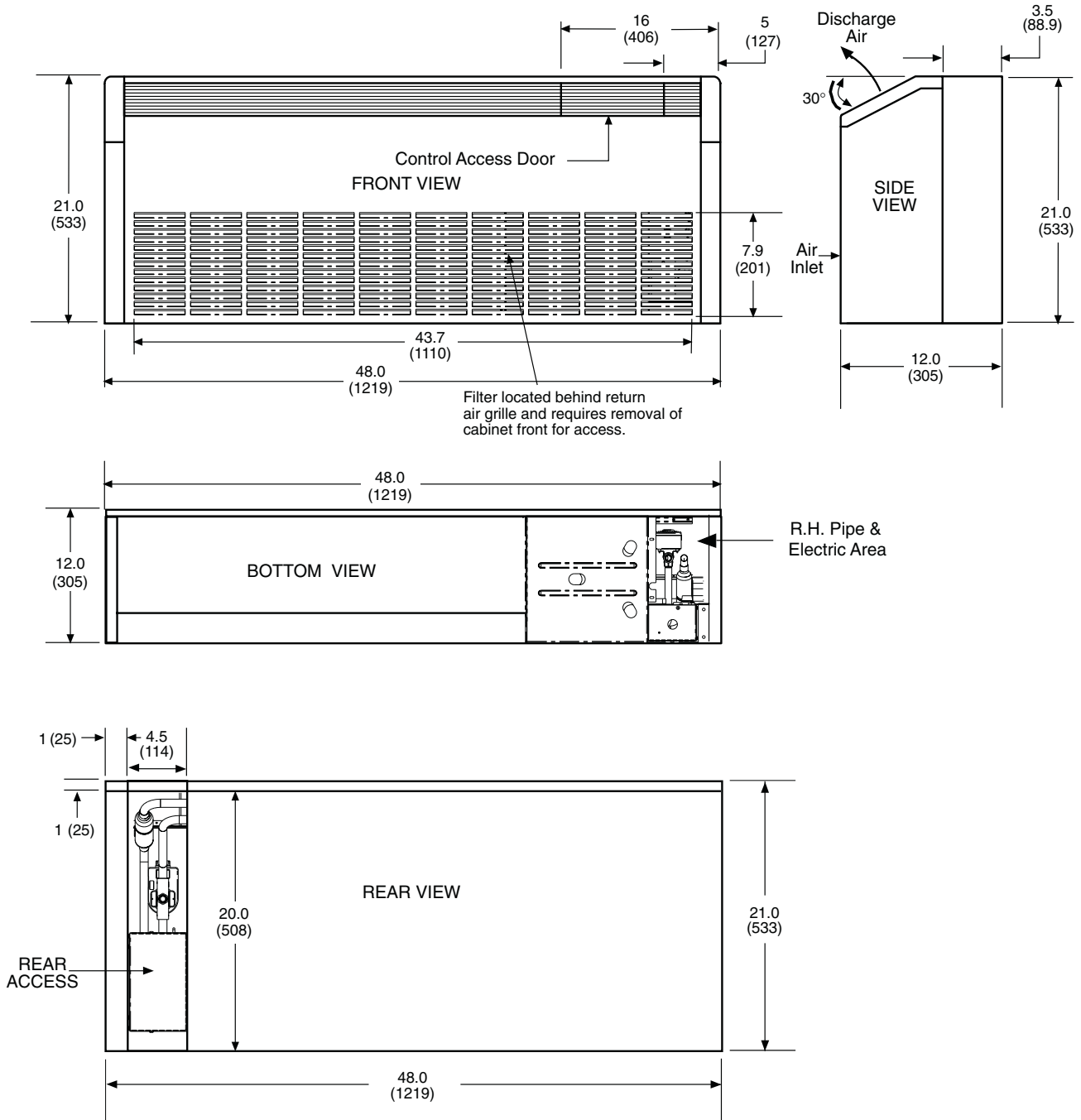

- NOTES:  
 1. Dimensions are shown in inches. Dimensions in parentheses are in millimeters.  
 2. Optional autoflow valve, motorized water valve and disconnect box are shown.

**Fig. 4 — 50KQL Front Return Cabinet Dimensions — Right-Hand Piping**

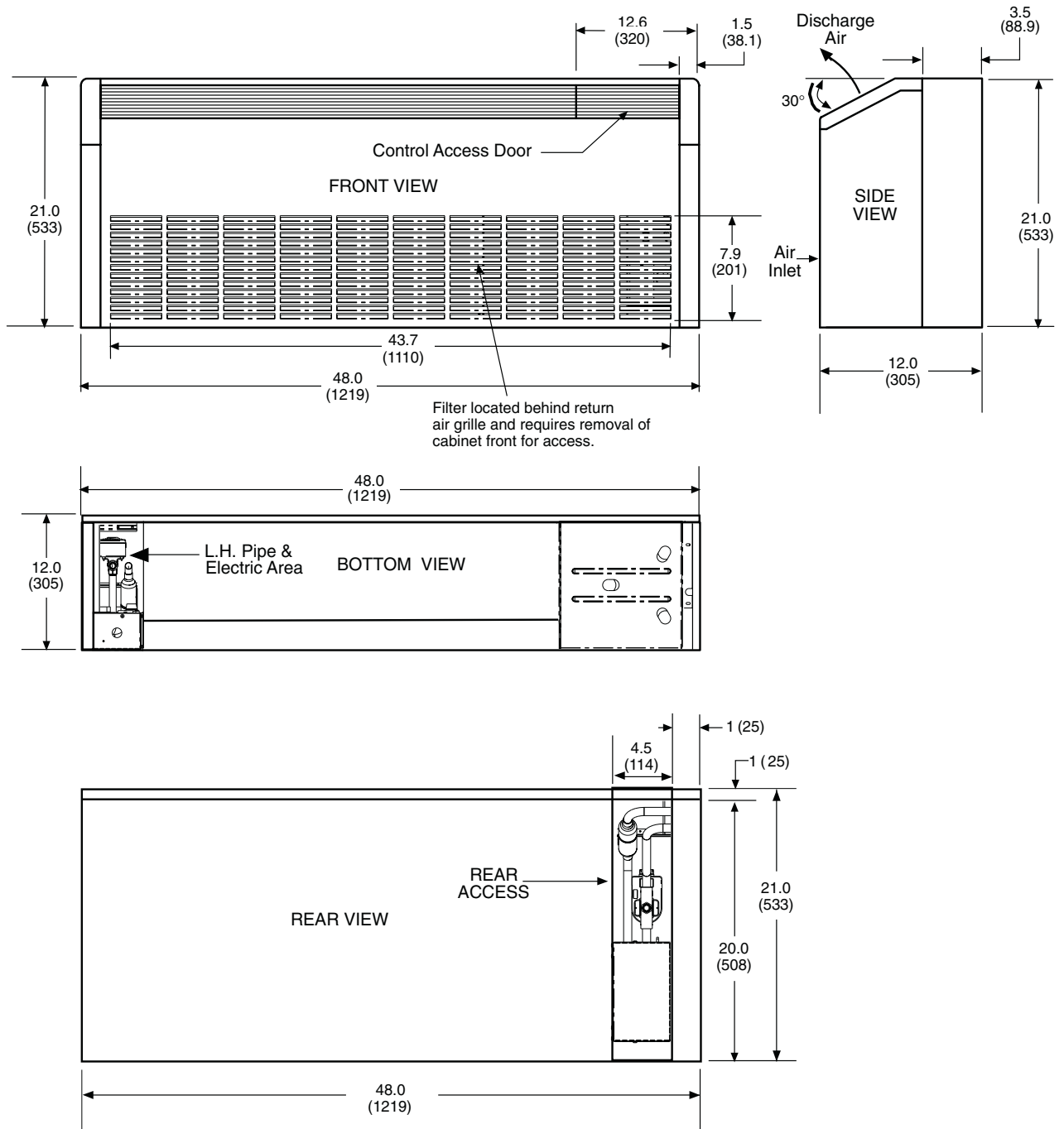

**NOTES:**

1. Dimensions are shown in inches. Dimensions in parentheses are in millimeters.
2. Optional autoflow valve, motorized water valve and disconnect box are shown.

**Fig. 5 — 50KQL Front Return Cabinet Dimensions — Left-Hand Piping**

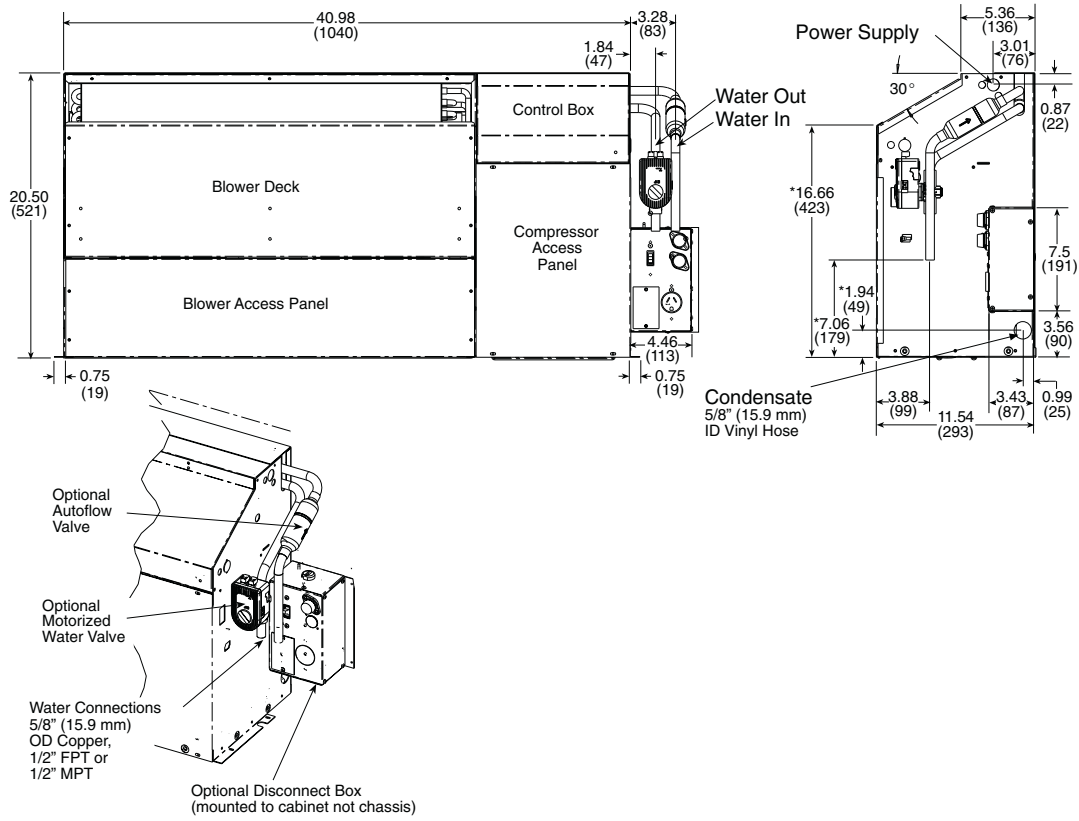

**RIGHT HAND CONFIGURATION**

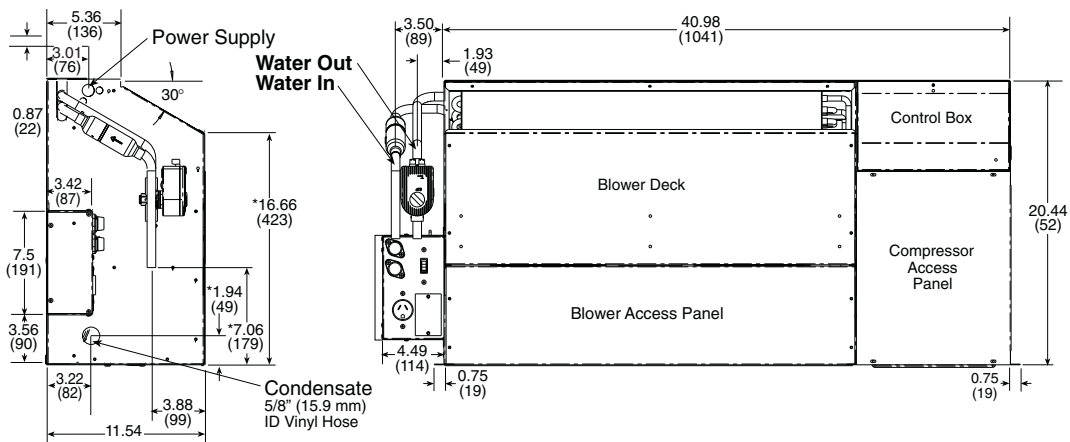

**LEFT HAND CONFIGURATION**

\*For installed dimension, add to dimension shown 2.9 in. for 3 in. subbase and 4.9 in. for 5 in. subbase.

**NOTES:**

1. Dimensions are shown in inches. Dimensions in parentheses are in millimeters.
2. Optional autoflow valve, motorized water valve and disconnect box are shown.
3. Water connection in same location regardless of connection type.

**Fig. 6 — 50KQL07-19 Chassis Dimensions**

**Step 2 — Check Unit** — Upon receipt of shipment at the jobsite, carefully check the shipment against the bill of lading. Make sure all units have been received. Inspect the carton or crating of each unit, and inspect each unit for damage. Ensure the shipping company makes proper notation of any shortages or damage on all copies of the freight bill. Concealed damage not discovered during unloading must be reported to the shipping company within 15 days of receipt of shipment.

NOTE: It is the responsibility of the purchaser to file all necessary claims with the shipping company.

**STORAGE**

**⚠ CAUTION**

DO NOT store or install console units in corrosive environments or in locations subject to temperature or humidity extremes (e.g., attics, garages, rooftops, etc.). Corrosive conditions and high temperature or humidity can significantly reduce performance, reliability, and service life. Always move units in an upright position. Tilting units on their sides may cause equipment damage.

Upon the arrival of equipment at the jobsite, immediately store units in their shipping cartons in a clean, dry area. **Store units in an upright position at all times. Stack units a maximum of 3 units high. Use pallets to separate each layer of units. DO NOT remove equipment from shipping cartons until equipment is required for installation.**

**UNIT PROTECTION** — Cover console units on the jobsite with either shipping cartons, vinyl film, or an equivalent protective covering. Cap the open ends of pipes stored on the jobsite. In areas where painting, plastering, or the spraying of fireproof material has not been completed, all due precautions must be taken to avoid physical damage to the units and contamination by foreign material. Physical damage and contamination may prevent proper start-up and may result in costly equipment clean-up.

Examine all pipes, fittings, and valves before installing any of the system components. Remove any dirt found on these components.

**Step 3 — Mounting the Unit**

1. Unpack the unit from the shipping carton. Remove the front cabinet by lifting up and away from the backplate. Protect the cabinet from damage during installation by returning it to its original vinyl pack until required.
2. Remove compressor isolation plate shipping screws (4), as shown in Fig. 7.
3. Using a carpenter’s square and a level, ensure the unit is level. Shim the unit if necessary to assure proper installation.

**Poor or inadequate installation may result in noisy unit operation or unattractive appearance.**

4. Select the proper fasteners to connect the backplate securely to the wall.

5. Fasten the backplate onto the wall through the screw holes located in the back flange. Secure the subbase in place.

**Step 4 — Electrical Wiring**

**⚠ WARNING**

To avoid possible injury or death due to electrical shock, open the power supply disconnect switch and secure it in an open position during installation.

**⚠ CAUTION**

Use only copper conductors for field installed electrical wiring. Unit terminals are not designed to accept other types of conductors.

All field installed wiring, including the electrical ground, **MUST** comply with National Electrical Code (NEC) as well as all applicable local codes. In addition, all field wiring must conform to the Class II temperature limitations described in the NEC.

Consult the unit wiring diagram located on the inside of the compressor access panel to ensure proper electrical hookup. The installing (or electrical) contractor must make the field connections shown in Fig. 8 when using field-supplied disconnect.

Operating voltage must be within voltage range shown in Electrical Data shown in Table 2.

Make all final electrical connections with a length of flexible conduit to minimize vibration and sound transmission to the building.

**SUPPLY VOLTAGE** — Operating voltage to unit must be within voltage range indicated on unit nameplate.

**EXTERNAL LOOP POWER CONNECTION** — If the unit will be connected to an external loop pump or flow controller, connect the pump to the loop pump terminal block PB1. The maximum power handling is 4 amps at 240 volts. The pumps will automatically cycle as required by the unit.

**230-VOLT OPERATION** — All 208-230 volt units are factory-wired for 208 volts. The transformer wiring may be switched for 230-volt operation (as illustrated on the wiring diagram) by switching the RED and ORG leads at L1.

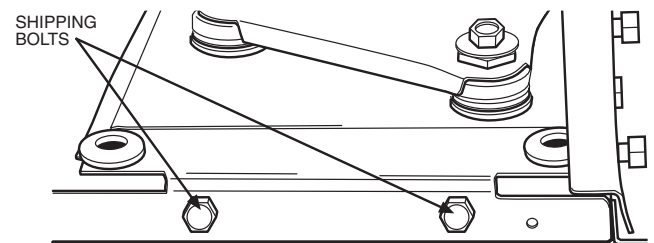

**Fig. 7 — Remove 4 Shipping Bolts on Compressor Isolator Plate**

**Table 2 — Electrical Data — 50KQE Units**

50KQL	VOLTS-PHASE (60 Hz)	MIN/MAX VOLTAGE	COMPRESSOR		FAN MOTOR FLA	TOTAL UNIT FLA	HI SPEED AIRFLOW	LO SPEED AIRFLOW	MIN CIRC AMP	MAX FUSE HACR
			RLA	LRA						
07	115-1	104/127	7.1	46.5	0.50	7.6	190	240	9.3	15
	208/230-1	187/253	3.7	19.0	0.33	4.0				
	265-1	239/291	2.8	16.0	0.35	3.1				
09	115-1	104/127	9.0	46.5	1.30	10.3	240	300	12.5	20
	208/230-1	187/253	4.7	23.0	0.50	5.2				
	265-1	239/291	3.8	16.0	0.50	4.3				
12	115-1	104/127	10.6	63.0	1.30	11.9	300	350	14.6	25
	208/230-1	187/253	6.1	29.0	0.50	6.6				
	265-1	239/291	4.8	21.6	0.50	5.3				
15	208/230-1	187/253	7.0	33.2	1.10	8.1	340	400	9.8	15
	265-1	239/291	5.4	29.0	1.00	6.4				
19	208/230-1	187/253	7.7	38.0	1.10	8.8	400	460	10.7	15
	265-1	239/291	5.8	29.0	1.00	6.8				

**LEGEND**

- FLA — Full Load Amps  
 HACR — Heating, Air Conditioning and Refrigeration  
 LRA — Locked Rotor Amps  
 MCA — Minimum Circuit Amps

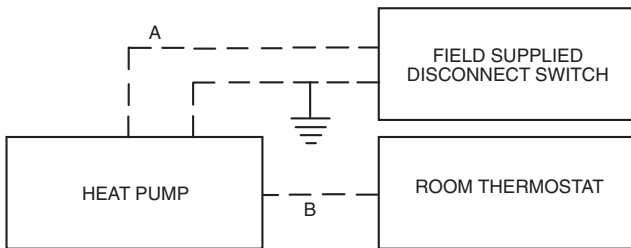

A = Two power wires for single-phase units.  
 B = 1 heat/1 cool/manual or auto changeover remote 24-V thermostat.

NOTE: All customer-supplied wiring to be copper only and must conform to national and local electrical codes. Wiring shown with dashed lines must be field-supplied and field-installed. "B" wiring only required with systems using remote-mounted thermostats.

**Fig. 8 — Typical Field-Installed Wiring**

**⚠ CAUTION**

Use copper conductors only to prevent equipment damage.

**⚠ WARNING**

Disconnect electrical power source to prevent injury or death from electrical shock.

### Step 5 — Low Voltage Wiring

**WATER FREEZE PROTECTION** — The Aquazone™ control allows the field selection of source fluid freeze protection points through jumpers. The factory setting of jumper JW3 (FP1) is set for water at 30 F. In earth loop applications, jumper JW3 should be clipped to change the setting to 10 F when using antifreeze in colder earth loop applications. See Fig. 9.

**ACCESSORY CONNECTIONS** — Terminal labeled A on the control is provided to control accessory devices such as water valves, electronic air cleaners, humidifiers, etc. This signal operates with the compressor terminal. See Fig. 10. Refer to the specific unit wiring schematic for details.

NOTE: The A terminal should *only* be used with 24-volt signals — not line voltage signals.

**WATER SOLENOID VALVES** — Water solenoid valves may be used on variable flow systems and ground water installations. A typical well water control valve wiring which can limit waste water in a lockout condition is shown in Fig. 10. A slow closing valve may be required to prevent water hammer. When using a slow closing valve, special wiring conditions need to be considered. The valve takes approximately 60 seconds to open (very little water will flow before 45 seconds) and it activates the compressor only after the valve is completely opened by closing its end switch. When wired as shown, the valve will have the following operating characteristics:

1. Remain open during a lockout.
2. Draw approximately 25 to 35 va through the "Y" signal of the thermostat.

**IMPORTANT:** This can overheat the anticipators of electromechanical thermostats. Only use relay based electronic thermostats.

**OPTIONAL WALL-MOUNTED THERMOSTAT** — The 50KQL water source heat pump units are built with standard internal thermostats in either manual changeover (MCO) or automatic changeover (ACO) configuration. Refer to Fig. 11-14.

When desired, the unit can be furnished with a 24-volt control circuit which is field-wired to a Carrier-supplied accessory remote thermostat. Most heat pump thermostats can be used with the controller. Use a thermostat with Y, G, O and W outputs. Refer to unit wiring diagrams in Fig. 15 and 16 and Aquazone Controls, Operation, and Troubleshooting Instructions for additional information.

Vendor installation instructions and additional installation information is shipped with each thermostat.

*Low-voltage wiring between the unit and the wall thermostat must comply with all applicable electrical codes (i.e., NEC and local codes), and be completed before the unit is installed.*

Table 3 lists recommended wire sizes and lengths to install the thermostat. The total resistance of low-voltage wiring must not exceed 1 ohm. Any resistance in excess of 1 ohm may cause the control to malfunction because of high voltage drop.

**OPTIONAL PREMIERLINK™ CONTROLLER** — This direct digital controller (DDC) allows the water source heat pump to be incorporated into a Carrier Comfort Network (CCN) system installation. PremierLink control is factory-installed with the Complete C controller, or field-installed with the Deluxe D option. Refer to Fig. 17.

**Table 3 — Recommended Thermostat Wire Sizes**

WIRE SIZE	MAX. WIRE LENGTH*
18-Gage	75 ft
16-Gage	125 ft
14-Gage	200 ft

\*Length = Physical distance from thermostat to unit.

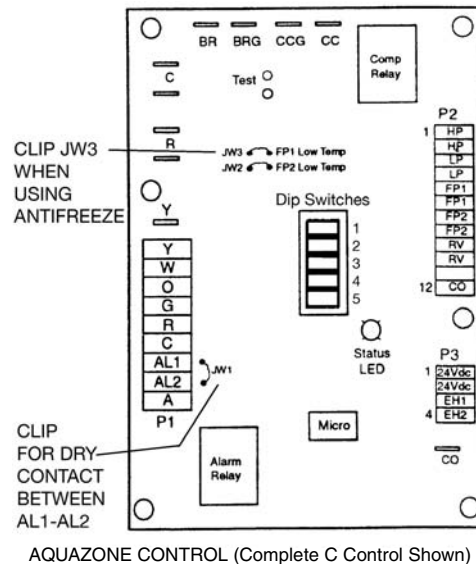

**Fig. 9 — Typical Aquazone Control Board Jumper Locations**

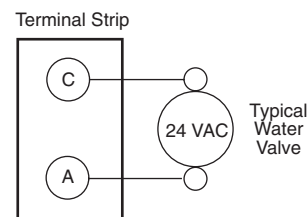

**Fig. 10 — Typical Aquazone Accessory Wiring**

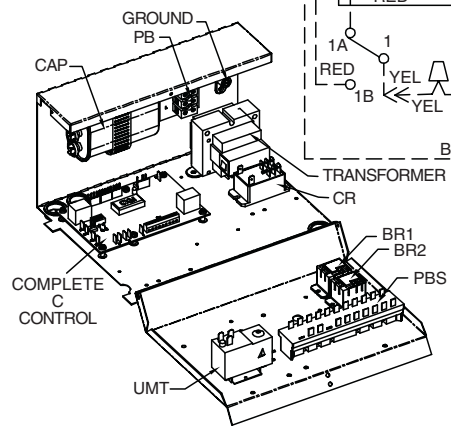
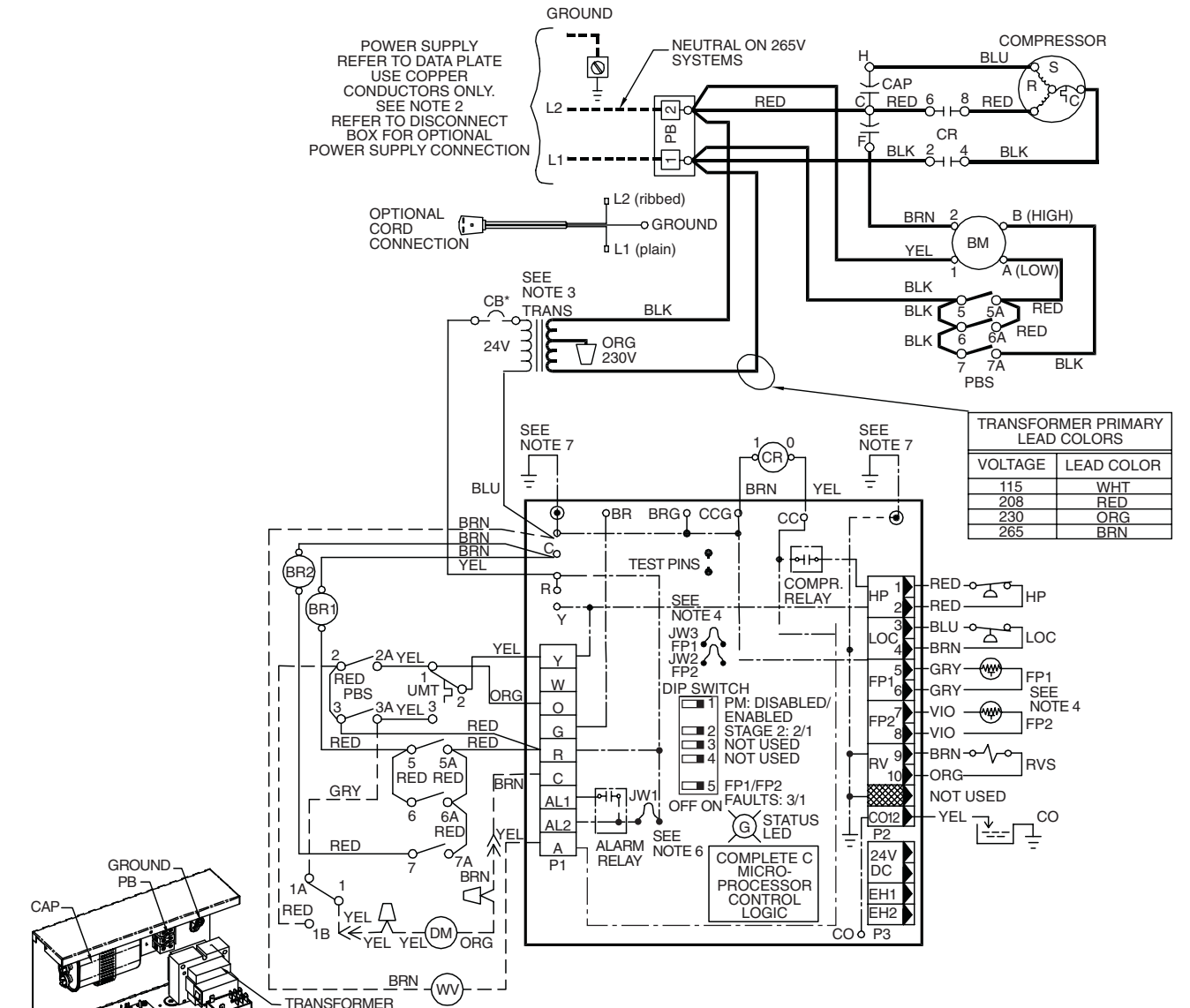

BLOWER MOTOR WIRING		
UNIT SIZE	POLE A	POLE B
07	5	3
09	5	4
12	4	3
15	4	3
19	4	3

PUSH BUTTON SWITCH ATTRIBUTES								
X = CLOSED      O = OPEN								
TERMINALS	1	2	3	4	5	6	7	8
	1A	1B	2A	3A	4A	5A	6A	7A
STOP	X	O	O	O	O	O	O	O
FAN ONLY	X	O	O	O	O	X	O	O
LOW FAN	X	O	O	X	X	O	X	O
HIGH FAN	X	O	O	X	X	O	O	X

- LEGEND**
- AL — Alarm Relay Contacts
  - BM — Blower Motor
  - BR — Blower Relay
  - CAP — Capacitor
  - CB — Circuit Breaker
  - CO — Sensor, Condensate Overflow
  - CR — Compressor Relay
  - DM — Damper Motor
  - FP1 — Sensor, Water Coil Freeze Protection
  - FP2 — Sensor, Air Coil Freeze Protection
  - HP — High-Pressure Switch
  - JW1 — Jumper Wire for Alarm
  - LOC — Loss of Charge Pressure Switch
  - PB — Power Terminal Block
  - PBS — Push Button Switch
  - PM — Performance Monitor
  - RVS — Reversing Valve Solenoid
  - TRANS — Transformer
  - UMT — Unit Mounted Thermostat
  - WV — Water Valve
  - Field Line Voltage Wiring
  - - - - - Field Low-Voltage Wiring
  - Printed Circuit Trace
  - - - - - Option Low Voltage Wiring
  - Relay/Contactor Coil
  - Solenoid Coil
  - Thermistor
  - Circuit Breaker
  - Relay Contacts-N.O.
  - Switch-Temperature
  - Switch-High Pressure
  - Switch-Low Pressure
  - ⊥ Ground
  - ⊥ Wire Nut
  - ⊥ Mate-N-Lock

- \*Optional wiring.
- NOTES:**
- Compressor and blower motor thermally protected internally.
  - All wiring to the unit must comply with local codes.
  - Transformer is wired to 115-V (WHT) lead for 115/1/60 units; 265-V (BRN) lead for 265/1/60 units; or 208-V (RED) lead for 208/1/60 units. For 230/1/60 operation, switch the RED and ORG leads at L1 and insulate the RED lead. Transformer is energy limiting or may have a circuit breaker.
  - FP1 thermistor provides freeze protection for WATER. When using ANTI-FREEZE solutions, cut JW3 jumper.
  - Typical unit-mounted thermostat wiring shown.
  - 24-V alarm signal shown. For dry alarm contact, cut JW1 jumper and dry contact will be available between AL1 and AL2.
  - Transformer secondary ground via Complete C board standoffs and screws to control box. (Ground available from top two standoffs as shown.)

**Fig. 11 — Manual Changeover with Complete C Controller Wiring**

POWER SUPPLY  
REFER TO DATA PLATE  
USE COPPER CONDUCTORS ONLY.  
SEE NOTE 2  
REFER TO DISCONNECT  
BOX FOR OPTIONAL  
POWER SUPPLY CONNECTION

BLOWER MOTOR WIRING		
UNIT SIZE	POLE A	POLE B
07	5	3
09	5	4
12	4	3
15	4	3
19	4	3

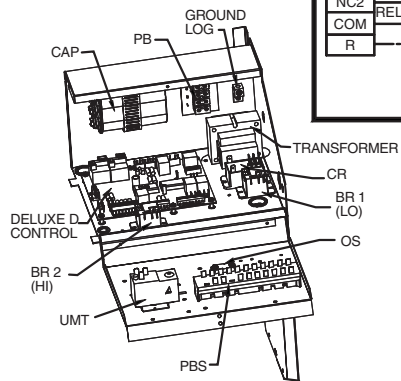
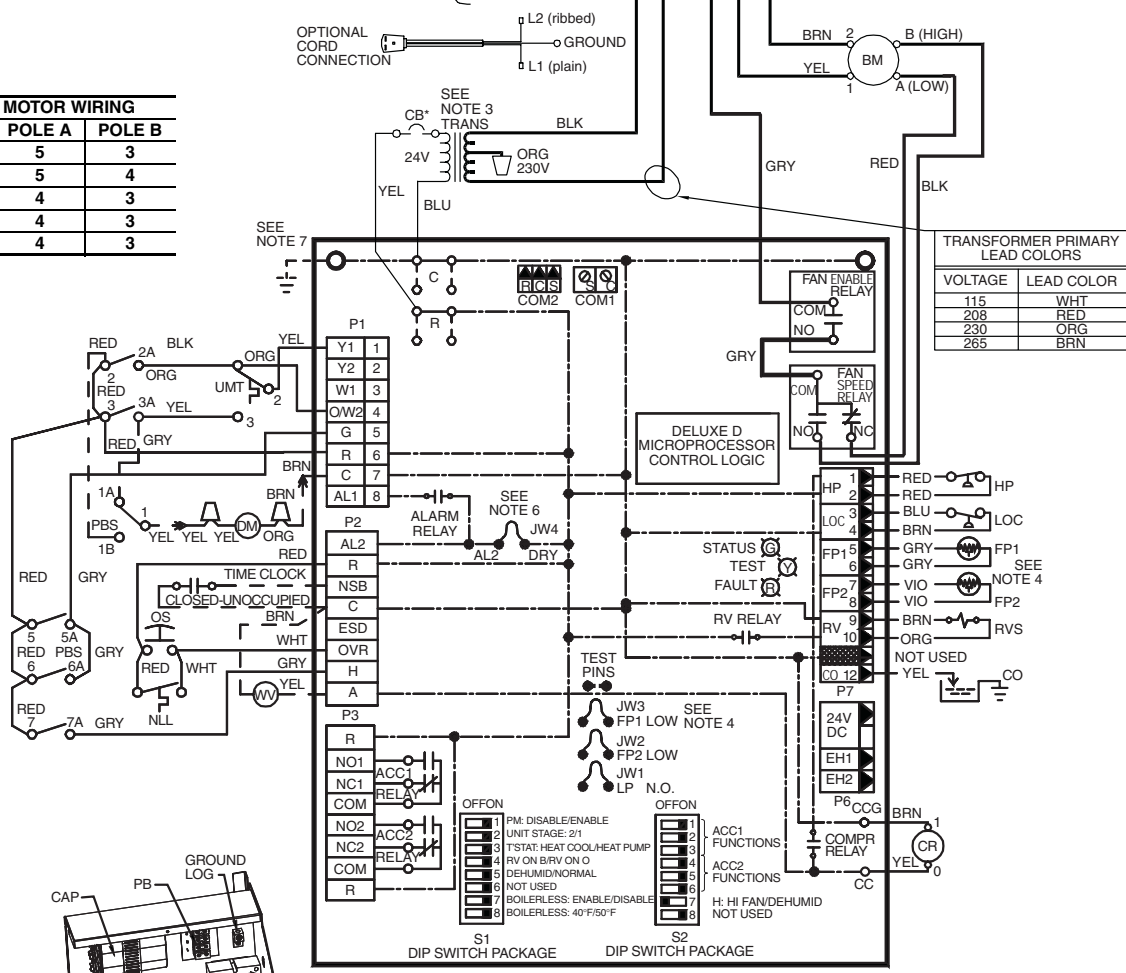

PUSH BUTTON SWITCH ATTRIBUTES									
TERMINALS	X = CLOSED				O = OPEN				
	1A	1B	2A	3A	4A	5A	6A	7A	8A
STOP	X	O	O	O	O	O	O	O	O
FAN ONLY	X	O	O	O	O	X	O	O	O
LOW COOL	O	X	X	O	O	O	X	O	O
HIGH COOL	O	X	X	O	O	O	O	X	O
LOW HEAT	X	O	O	X	X	O	X	O	O
HIGH HEAT	X	O	O	X	X	O	O	X	X

- LEGEND**
- AL — Alarm Relay Contacts
  - BM — Blower Motor
  - BR — Blower Relay
  - CAP — Capacitor
  - CB — Circuit Breaker
  - CO — Sensor, Condensate Overflow
  - CR — Compressor Relay
  - DM — Damper Motor
  - FP1 — Sensor, Water Coil Freeze Protection
  - FP2 — Sensor, Air Coil Freeze Protection
  - HP — High-Pressure Switch
  - JW1 — Jumper Wire for Alarm
  - LOC — Loss of Charge Pressure Switch
  - NLL — Night Low Limit Switch
  - OS — Override Switch
  - PB — Power Terminal Block
  - PBS — Push Button Switch
  - PM — Performance Monitor
  - RVS — Reversing Valve Solenoid
  - TRANS — Transformer
  - UMT — Unit Mounted Thermostat
  - WV — Water Valve
  - Field Line Voltage Wiring
  - - - - - Field Low-Voltage Wiring

- Printed Circuit Trace
- - - - - Option Low Voltage Wiring
- ⊖ Relay/Contactor Coil
- ⊖ Solenoid Coil
- ⊖ Thermistor
- ⊖ Circuit Breaker
- ⊖ Relay Contacts-N.O.
- ⊖ Switch-Temperature
- ⊖ Switch-High Pressure
- ⊖ Switch-Low Pressure
- ⊖ Ground
- ⊖ Wire Nut
- ⊖ Mate-N-Lock

- \*Optional wiring.
- NOTES:
- Compressor and blower motor thermally protected internally.
  - All wiring to the unit must comply with local codes.
  - Transformer is wired to 115-V (WHT) lead for 115/1/60 units; 265-V (BRN) lead for 265/1/60 units; or 208-V (RED) lead for 208/1/60 units. For 230/1/60 operation, switch the RED and ORG leads at L1 and insulate the RED lead. Transformer is energy limiting or may have a circuit breaker.
  - FP1 thermistor provides freeze protection for WATER. When using ANTI-FREEZE solutions, cut JW3 jumper.
  - Typical unit-mounted thermostat wiring shown.
  - 24-V alarm signal shown. For dry alarm contact, cut AL2 DRY (JW4) jumper and dry contact will be available between AL1 and AL2.
  - Transformer secondary ground via Deluxe D board standoffs and screws to control box. (Ground available from top two standoffs as shown.)

Fig. 12 — Manual Changeover with Deluxe D Controller Wiring

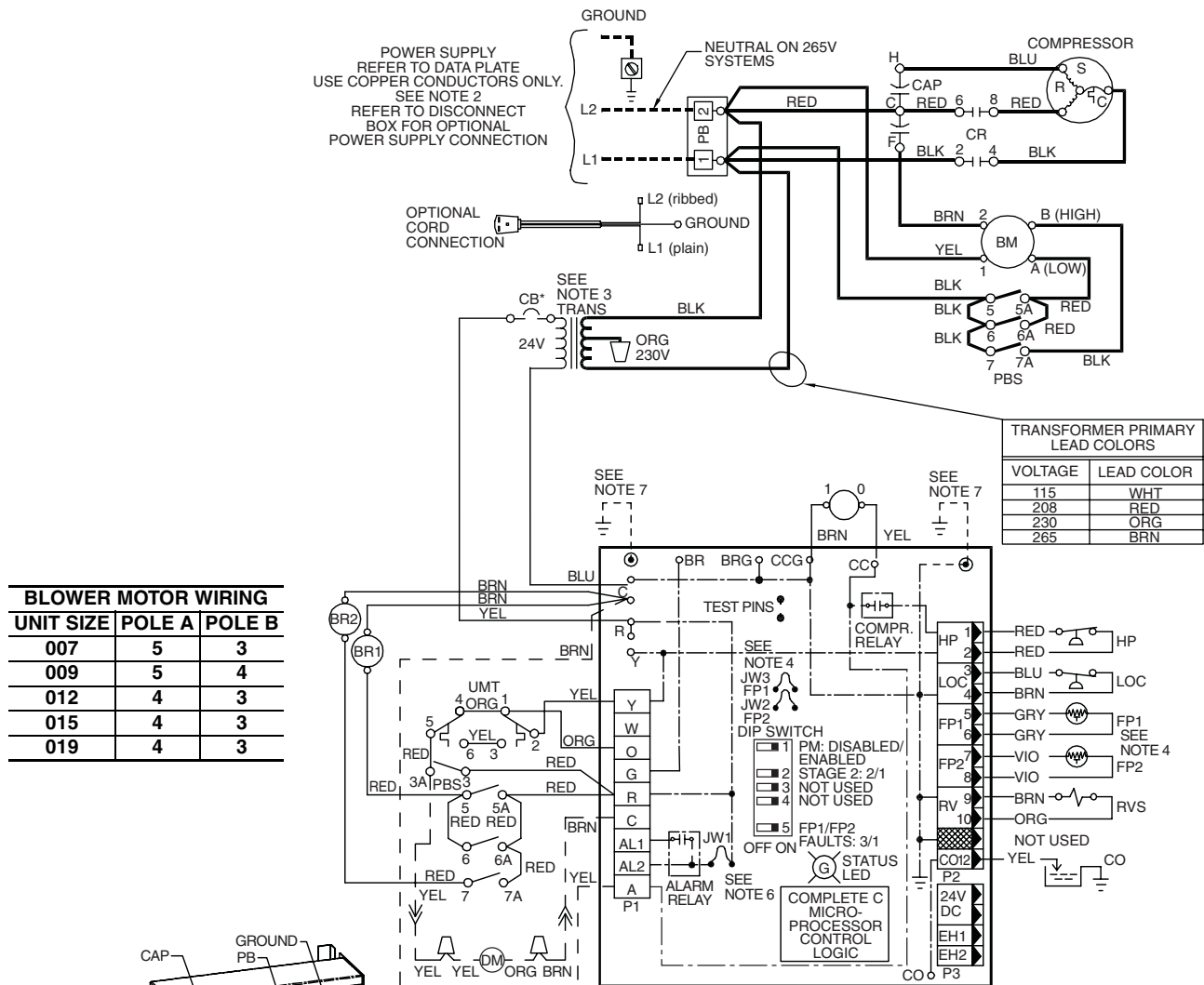

BLOWER MOTOR WIRING		
UNIT SIZE	POLE A	POLE B
007	5	3
009	5	4
012	4	3
015	4	3
019	4	3

TRANSFORMER PRIMARY LEAD COLORS	
VOLTAGE	LEAD COLOR
115	WHT
208	RED
230	ORG
265	BRN

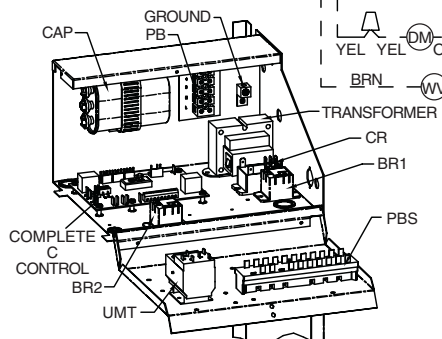

PUSH BUTTON SWITCH ATTRIBUTES									
TERMINALS	X = CLOSED				O = OPEN				
	1A	1B	2A	3A	4A	5A	6A	7A	8A
STOP	X	O	O	O	O	O	O	O	O
FAN ONLY	X	O	O	O	O	X	O	O	O
LOW FAN	X	O	O	X	X	O	X	O	O
HIGH FAN	X	O	O	X	X	O	O	X	X

- LEGEND**
- AL — Alarm Relay Contacts
  - BM — Blower Motor
  - BR — Blower Relay
  - CAP — Capacitor
  - CB — Circuit Breaker
  - CO — Sensor, Condensate Overflow
  - CR — Compressor Relay
  - DM — Damper Motor
  - FP1 — Sensor, Water Coil Freeze Protection
  - FP2 — Sensor, Air Coil Freeze Protection
  - HP — High-Pressure Switch
  - JW1 — Jumper Wire for Alarm
  - LOC — Loss of Charge Pressure Switch
  - PB — Power Terminal Block
  - PBS — Push Button Switch
  - PM — Performance Monitor
  - RVS — Reversing Valve Solenoid
  - TRANS — Transformer
  - UMT — Unit Mounted Thermostat
  - WV — Water Valve
  - Field Line Voltage Wiring
  - - - - - Field Low-Voltage Wiring

- Printed Circuit Trace
- - - - - Option Low Voltage Wiring
- Relay/Contactor Coil
- ⊕ Solenoid Coil
- ⊕ Thermistor
- ⊕ Circuit Breaker
- ⊕ Relay Contacts-N.O.
- ⊕ Switch-Temperature
- ⊕ Switch-High Pressure
- ⊕ Switch-Low Pressure
- ⊕ Ground
- ⊕ Wire Nut
- ⊕ Mate-N-Lock

- \*Optional wiring.
- NOTES:**
- Compressor and blower motor thermally protected internally.
  - All wiring to the unit must comply with local codes.
  - Transformer is wired to 115-V (WHT) lead for 115/1/60 units; 265-V (BRN) lead for 265/1/60 units; or 208-V (RED) lead for 208/1/60 units.  
For 230/1/60 operation, switch the RED and ORG leads at L1 and insulate the RED lead. Transformer is energy limiting or may have a circuit breaker.
  - FP1 thermistor provides freeze protection for WATER. When using ANTI-FREEZE solutions, cut JW3 jumper.
  - Typical unit-mounted thermostat wiring shown.
  - 24-V alarm signal shown. For dry alarm contact, cut JW1 jumper and dry contact will be available between AL1 and AL2.
  - Transformer secondary ground via Complete C board standoffs and screws to control box. (Ground available from top two standoffs as shown.)

**Fig. 13 — Automatic Changeover with Complete C Controller Wiring**

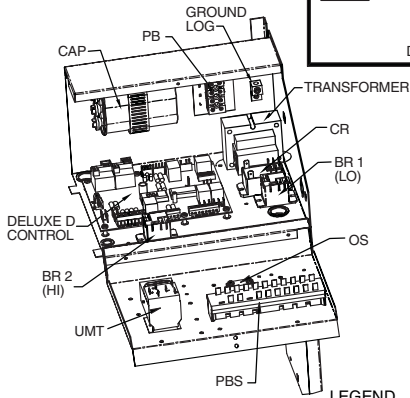
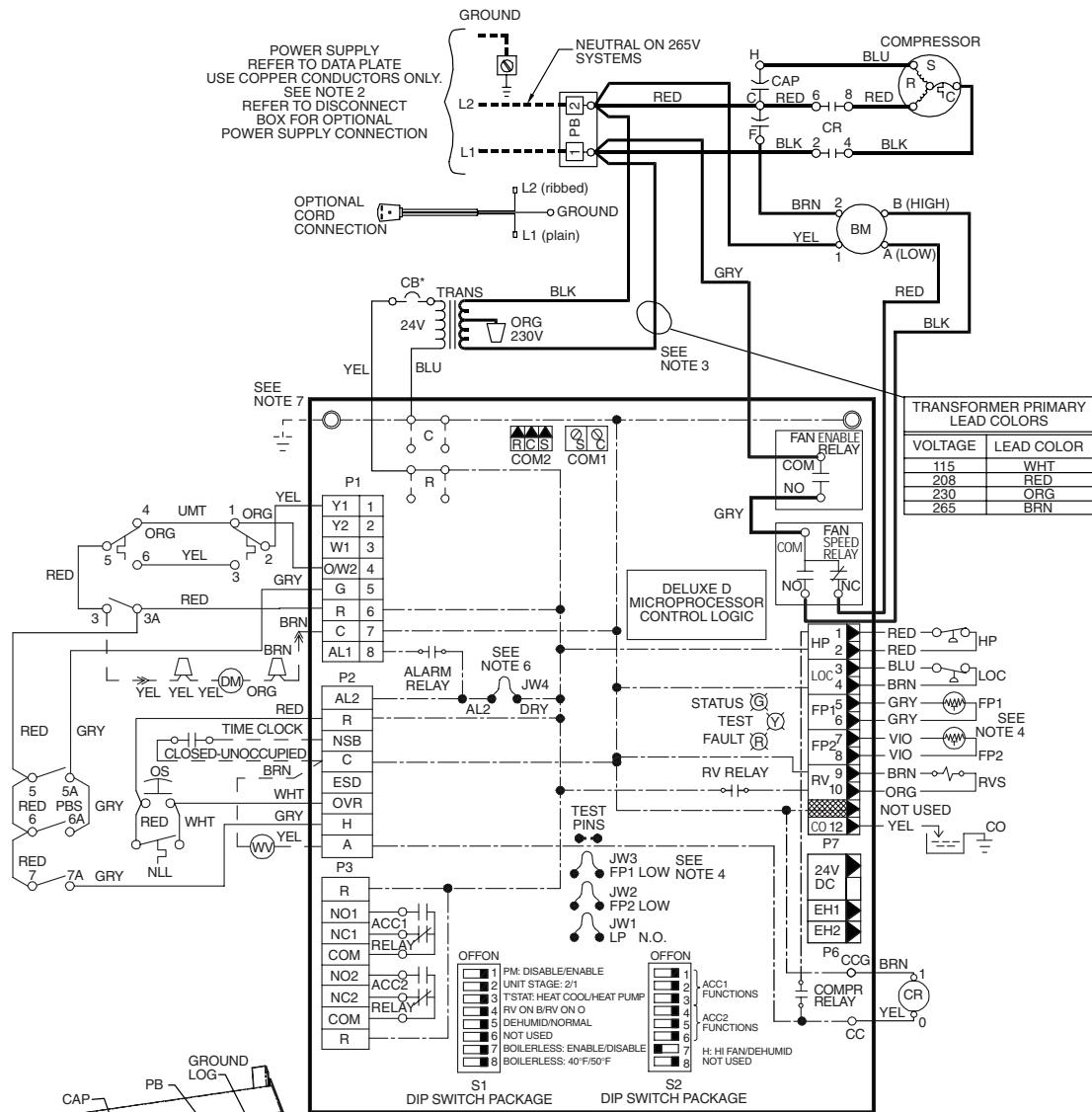

PUSH BUTTON SWITCH ATTRIBUTES									
TERMINALS	X = CLOSED				O = OPEN				
	1A	1B	2A	3A	4A	5A	6A	7A	8A
STOP	X	O	O	O	O	O	O	O	O
FAN ONLY	X	O	O	O	X	O	O	O	O
LOW FAN	X	O	O	X	X	O	X	O	O
HIGH FAN	X	O	O	X	X	O	O	X	X

BLOWER MOTOR WIRING		
UNIT SIZE	POLE A	POLE B
07	5	3
09	5	4
12	4	3
15	4	3
19	4	3

- LEGEND**
- AL — Alarm Relay Contacts
  - BM — Blower Motor
  - BR — Blower Relay
  - CAP — Capacitor
  - CB — Circuit Breaker
  - CO — Sensor, Condensate Overflow
  - CR — Compressor Relay
  - DM — Damper Motor
  - FP1 — Sensor, Water Coil Freeze Protection
  - FP2 — Sensor, Air Coil Freeze Protection
  - JW1 — High-Pressure Switch
  - JW4 — Jumper Wire for Alarm
  - LOC — Loss of Charge Pressure Switch
  - NLL — Night Low Limit Switch
  - OS — Override Switch
  - PBS — Power Terminal Block
  - PM — Push Button Switch
  - PM — Performance Monitor
  - RVS — Reversing Valve Solenoid
  - TRANS — Transformer
  - UMT — Unit Mounted Thermostat
  - WV — Water Valve
  - Field Line Voltage Wiring
  - - - - - Field Low-Voltage Wiring

- Printed Circuit Trace
- Option Low Voltage Wiring
- Relay/Contactor Coil
- Solenoid Coil
- Thermistor
- Circuit Breaker
- Relay Contacts-N.O.
- Switch-Temperature
- Switch-High Pressure
- Switch-Low Pressure
- Ground
- Wire Nut
- Mate-N-Lock

- \*Optional wiring.
- NOTES:**
- Compressor and blower motor thermally protected internally.
  - All wiring to the unit must comply with local codes.
  - Transformer is wired to 115-V (WHT) lead for 115/1/60 units; 265-V (BRN) lead for 265/1/60 units; or 208-V (RED) lead for 208/1/60 units. For 230/1/60 operation, switch the RED and ORG leads at L1 and insulate the RED lead. Transformer is energy limiting or may have a circuit breaker.
  - FP1 thermistor provides freeze protection for WATER. When using ANTI-FREEZE solutions, cut JW3 jumper.
  - Typical unit-mounted thermostat wiring shown.
  - 24-V alarm signal shown. For dry alarm contact, cut AL2 DRY (JW4) jumper and dry contact will be available between AL1 and AL2.
  - Transformer secondary ground via Deluxe D board standoffs and screws to control box. (Ground available from top two standoffs as shown.)

**Fig. 14 — Automatic Changeover with Deluxe D Controller Wiring**

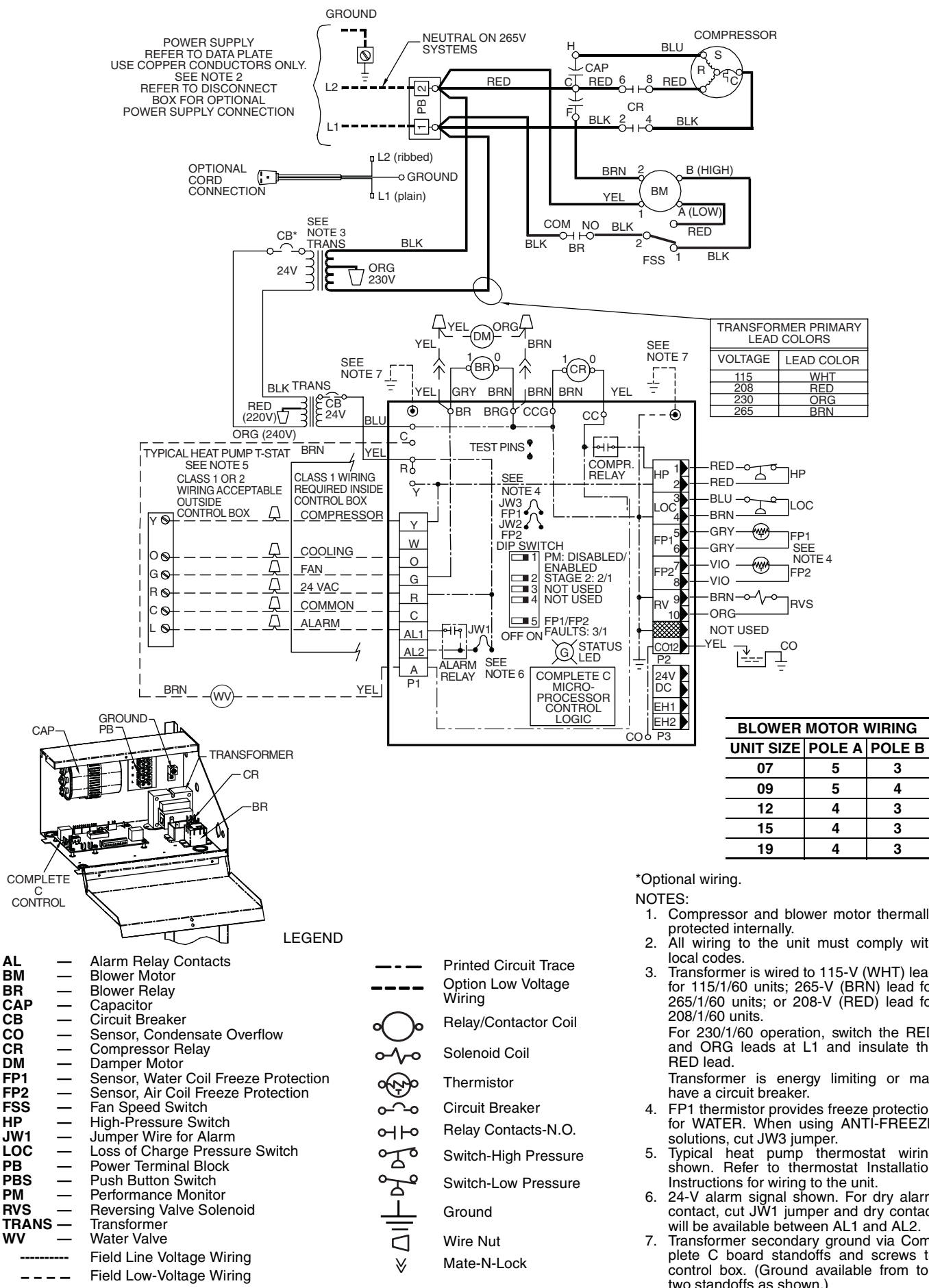

**Fig. 15 — Remote Mounted Thermostat with Complete C Controller Wiring**



PREMIERLINK™ CONTROLLER APPLICATIONS WITH COMPLETE C CONTROL

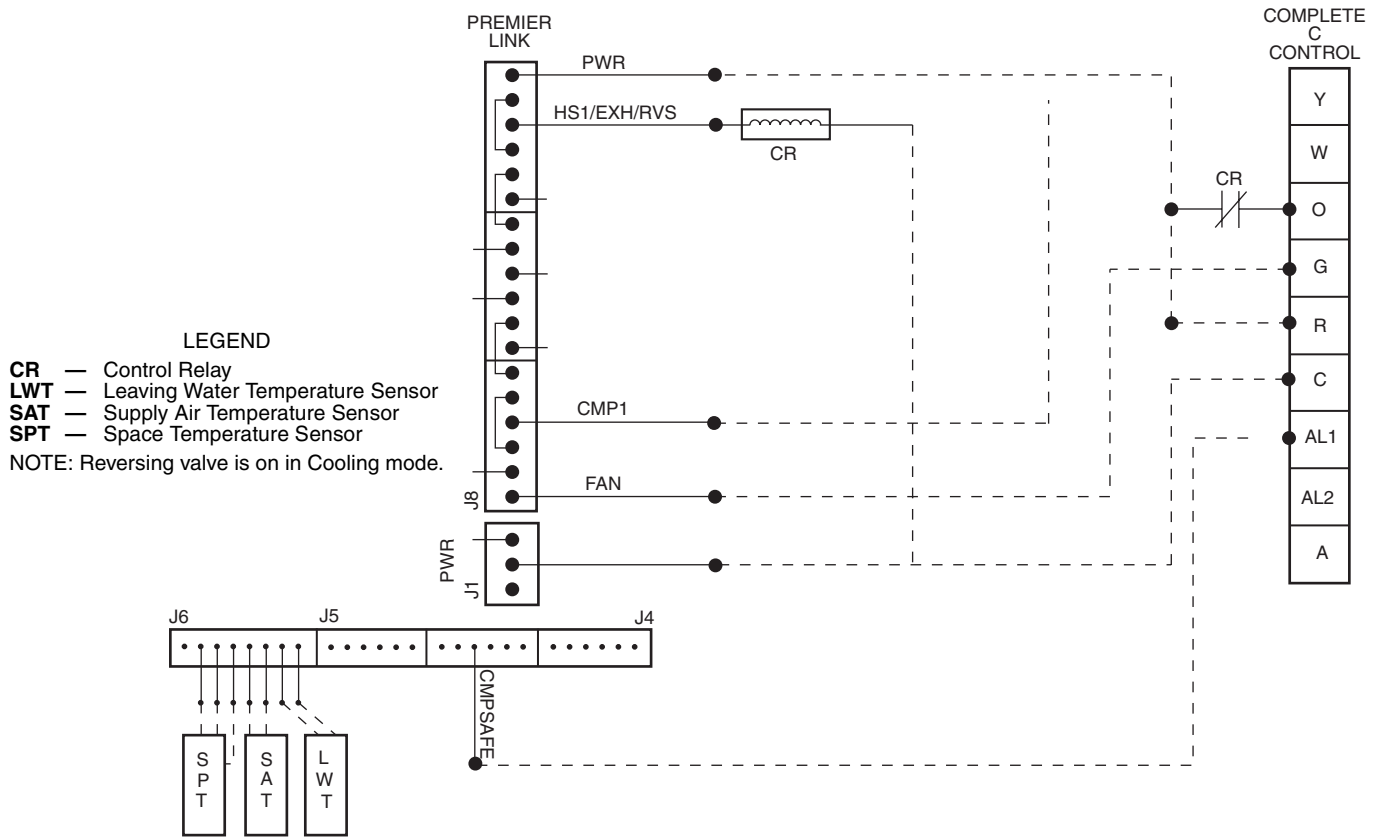

PREMIERLINK CONTROLLER APPLICATIONS WITH DELUXE D CONTROL

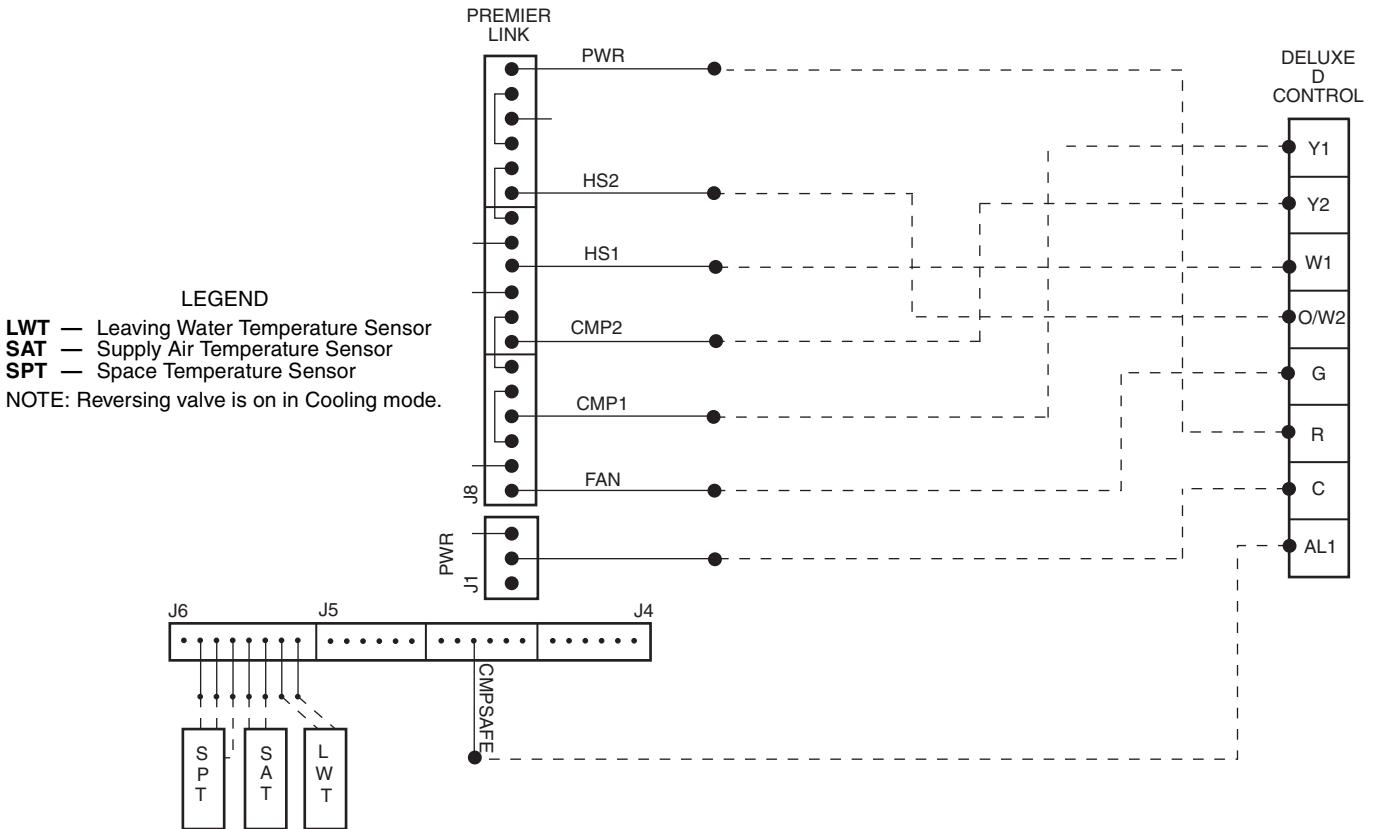

Fig. 17 — Typical PremierLink Control Wiring

## Step 6 — Supply and Return Piping Installation

### IMPORTANT:

**Right Hand Units — Entering Water is upper pipe.  
Left Hand Units — Entering Water is lower pipe.**

### ⚠ CAUTION

To ensure proper functioning of unit and system, be sure to connect entering water to upper pipe on right-hand units. On left-hand units, connect entering water to lower pipe.

**SUPPLY AND RETURN HOSES** — Optional pressure-rated hose assemblies are available for use with units. Use the following guidelines when installing supply and return hose assemblies.

1. Install supply and return hoses fitted with swivel-joint fittings at one end to prevent the hose from twisting.
2. Use male adapters to secure the hose assembly to the unit and the riser.
3. Do not allow the hose to twist during installation. Twisting may damage the hose wall or the rubber compound.
4. Use pipe joint compound sparingly on the fitting adapters' male pipe threads.
5. Prevent sealant from reaching the joint's flared surfaces.
6. Do not use pipe joint compound when Teflon thread tape is pre-applied to hose assemblies or when flared-end connections are used.
7. Maximum torque that may be applied to brass fittings is 30 ft-lb. When a torque wrench is not used, tighten brass fittings finger-tight plus one quarter turn.
8. Tighten steel fittings as necessary.
9. Shut-off/balancing valves, flow indicators, and drain tees in the supply runout and return at each floor aid in loop balancing and servicing.

**SUPPLY AND RETURN PIPING** — System piping **MUST** comply with all applicable codes.

1. Install a drain valve at the base of each supply and return riser to enable system flushing at start-up and during routine servicing.
2. Install shut-off/balancing valves and unions at each unit to allow unit removal for servicing.

**NOTE: If flex hoses are used, unions are not necessary.**

3. Install strainers at the inlet of each system circulating pump.

**NOTE: Since loop temperatures are normally between 60 and 90 F, pipe sweating and heat loss do not occur at normal ambient temperature conditions. Insulation must be installed on loop water piping on those sections that run through unheated areas or are located outside the building. If loop temperatures are expected below the ambient dew point, the optional internal insulation (extended range) package must be ordered.**

### ⚠ CAUTION

DO NOT bend or kink supply lines or hoses. Damage to unit may result.

4. Before making the final water connections, flush the system as described in the Pre-Start-Up section of this manual. After flushing the system, connect piping and hoses to the proper supply, return and condensate connections of the unit.

**NOTE: When necessary, use adapters to connect hoses.**

5. Install any other system components, as required, following manufacturer's instructions.

6. Reinstall the front cabinet by carefully lowering the front cabinet over the chassis onto the backplate.

## Step 7 — Condensate Piping Installation —

Connect the unit condensate drain to the building condensate drain with a flexible, nonpressure-rated  $\frac{3}{8}$ -in. (16 mm) ID plastic hose. Avoid kinks in this hose to ensure an unobstructed flow of condensate from the unit to the drain.

The horizontal run of the condensate hose is usually too short to pose any drainage problems, however, the horizontal run of condensate line should be pitched at least 1 in. for every 10 feet of run (in the direction of flow). Avoid low points and unpitched piping since dirt collects in these areas and may cause stoppage and overflow.

Field installation of a trap or vent is not required unless specified by local codes. The 50KQL units are designed in a blow-thru configuration. The condensate drain pan is located on the outlet side of the blower so that the pressure in the drain pan is higher than the atmospheric pressure.

### PRE-START-UP

**System Cleaning and Flushing** — Cleaning and flushing the unit and system is the single most important step to ensure proper start-up and continued efficient operation of the system.

### ⚠ WARNING

To prevent injury or death due to electrical shock or contact with moving parts, open unit disconnect before servicing unit.

Follow the instructions below to properly clean and flush the system:

### ⚠ CAUTION

**DO NOT FLUSH SYSTEM THROUGH THE UNIT!**

1. Verify that electrical power to the units is disconnected, and that the circulation pump is deenergized.
2. Connect the supply hose directly to the return riser valve. Use a single length of flexible hose, as shown in Fig. 18.

**NOTE:** If the length of hose is too short (i.e., the resulting connection would exceed the minimum bend radius of the hose), substitute two lengths of flexible hose joined together with a field-supplied, standard NPT coupling and the flare-fitting-to-pipe adapters provided with the hose kit (Fig. 18).

3. Open all air vents. Fill the system with water. Do not allow system to overflow. Bleed all air from the system. Check the system for leaks and repair appropriately.
4. Check and adjust the water and air level in the expansion tank.
5. Verify all strainers are in place. Start the pumps, and systematically check each vent to ensure all air is bled from the system.
6. Verify make-up water is available. Adjust make-up water appropriately to replace the air that was bled from the system. Pressure test and inspect the system for leaks and make any necessary repairs. Check and adjust the water and air level in the expansion tank.
7. Open a drain at the lowest point in the system. Adjust the make-up water replacement rate to equal the rate of bleed. Continue to bleed the system until the water appears clean or for at least three hours, whichever is longest; then, completely drain the system.
8. Refill the system with clean, chemically treated water. Since water varies for each locality, contact a local water treatment company for the correct treatment chemicals to use in your area. Set the boiler to raise the loop temperature to approximately 85 F.

**⚠ CAUTION**

To avoid possible damage to piping systems constructed of plastic piping DO NOT allow loop temperature to exceed 110 F.

Circulate the solution for a minimum of 8 to 24 hours. At the end of this period, shut off the circulating pump and drain the solution. Repeat system cleaning as necessary.

9. When the cleaning process is complete, remove the short-circuited hoses. Connect the hoses to the proper supply and return connections on each unit. Refill the system and bleed off all air.
10. Test the system pH with litmus paper. The system water should be slightly alkaline (pH 7.0 to 8.5). Add chemicals, as appropriate, to maintain acidity levels.

**⚠ CAUTION**

DO NOT use “Stop-Leak” or any similar chemical agent in this system. Addition of these chemicals to the loop water will foul the system and will inhibit unit operation.

11. When the system is successfully cleaned, flushed, refilled and bled, check the main system panels, safety cutouts and alarms. Set the controls to properly maintain loop temperatures.

**System Checkout** — When the installation is complete and the system is cleaned and flushed, follow the System Checkout procedure outlined below.

1. Voltage: Ensure voltage is within the utilization range specifications of the unit compressor and fan motor.
2. System Water Temperature: Ensure temperature is within an acceptable range shown in Table 4. (When conducting this check, also verify proper heating and cooling set points.)
3. System Water pH: Verify system water is slightly alkaline (pH = 7.5 to 8.5). Proper pH promotes the longevity of the hoses and heat exchangers. See Table 5.
4. Closed-Type Cooling Tower (Open Tower with Heat Exchanger): Check equipment for proper temperature set points and operation.
5. Balanced Water Flow Rate to Heat Pump: Record the inlet and outlet water temperatures as each heat pump unit is started. This check will eliminate nuisance unit tripouts resulting from water velocities that are either too low or too high; it can also prevent erosive water flow rates.

6. Standby Pump: Verify the standby pump is properly installed and in operating condition.
7. System Control: To ensure no catastrophic system failures occur, verify system controls are functioning and the sequencing is correct.
8. Freeze Protection for Water Systems: Verify freeze protection is provided for the outdoor portion of the loop water system. Inadequate freeze protection leads to expensive repairs.

**⚠ CAUTION**

To avoid equipment damage, DO NOT leave system filled in a building without heat during the winter unless anti-freeze is added to system water. Condenser coils never fully drain by themselves and will freeze unless winterized with antifreeze.

9. System Water Loop: Verify all air is bled from the system. Air in the system impedes unit operation and causes corrosion in the system piping.
10. Unit Filters: To avoid system damage and to provide maximum performance, ensure the unit filter is clean.
11. Unit Fans: Manually rotate fans to assure free rotation. Ensure fans are properly secured to the fan shaft. Do not oil fan motors on start-up since they are lubricated at the factory.
12. System Control Center: To ensure control of the temperature set points for operation of the system’s heat rejector and boiler, examine the system control and alarm panel for proper installation and operation.

**Table 4 — Air and Water Limits**

	50KQL	
	Cooling (F)	Heating (F)
Min. Ambient Air	50	50
Rated Ambient Air	80	70
Max. Ambient Air	100	85
Min. Entering Air	50	50
Rated Entering Air, db/wb	80/67	70
Max. Entering Air, db/wb	100/83	80
Min. Entering Water	30	20
Normal Entering Water	85	70
Max. Entering Water	110	90

NOTES:

1. Minimum air and water conditions can only be used at nominal flow rates.
2. 50KQL units may have up to two values at maximum or minimum with all other parameters at normal conditions.
3. Operating limits shown are for Start-Up, not continuous operation. It is assumed that such a start-up is for the purpose of bringing the space to desired occupancy temperature.

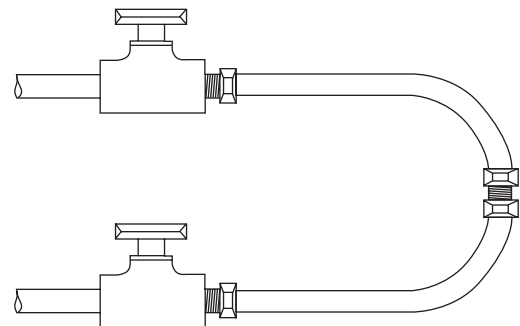
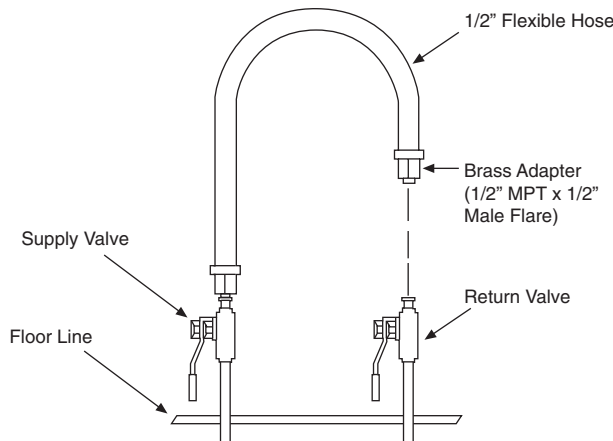

NOTE: Use standard coupling (field-supplied) and hose adapters to join 2 hoses.

**Fig. 18 — Temporary Connection for Flushing System Piping**

**Table 5 — Water Quality Guidelines**

CONDITION	ACCEPTABLE LEVEL		
pH	7 to 9 range for copper. Cupronickel may be used in the 5 to 9 range.		
Total Hardness	Calcium and magnesium carbonate should not exceed 350 ppm.		
Iron Oxides	Less than 1 ppm.		
Iron Bacteria	No level allowable.		
Corrosion*		Max Allowable Level	Coaxial Metal
	Ammonia, Ammonium Hydroxide	0.5 ppm	Cu
	Ammonium Chloride, Ammonium Nitrate	0.5 ppm	Cu
	Ammonium Sulfate	0.5 ppm	Cu
	Chlorine/Chlorides	0.5 ppm	CuNi
	Hydrogen Sulfide†	None Allowable	—
Brackish	Use Cupronickel heat exchanger when concentrations of calcium or sodium chloride are greater than 125 ppm are present. (Seawater is approximately 25,000 ppm.)		

\*If the concentration of these corrosives exceeds the maximum allowable level, then the potential for serious corrosion problems exists.

†Sulfides in the water quickly oxidize when exposed to air, requiring that no agitation occur as the sample is taken. Unless tested immediately at the site, the sample will require stabilization with a few drops of one Molar zinc acetate solution, allowing accurate sulfide determination up to 24 hours after sampling. A low pH and high alkalinity cause system problems, even when both values are within ranges shown. The term pH refers to the acidity, basicity, or neutrality of the water supply. Below 7.0, the water is considered to be acidic. Above 7.0, water is considered to be basic. Neutral water contains a pH of 7.0.

NOTE: Hardness in mg/l is equivalent to ppm.

**IMPORTANT:** Failure to comply with the above required water quality and quantity limitations and the closed-system application design requirements may cause damage to the tube-in-tube heat exchanger and will void manufacturer's warranty.

**FIELD SELECTABLE INPUTS**

Jumpers and DIP (dual in-line package) switches on the control board are used to customize unit operation and can be configured in the field.

**IMPORTANT:** Jumpers and DIP switches should only be clipped when power to control board has been turned off.

**Complete C Control Jumper Settings (See Fig. 11 and 13)**

**WATER COIL FREEZE PROTECTION (FP1) LIMIT SETTING** — Select jumper 3, (JW3-FP1 Low Temp) to choose FP1 temperature limit of 10 F or 30 F. To select 30 F as the temperature limit, DO NOT clip the jumper. To select 10 F as the limit, clip the jumper.

**ALARM RELAY SETTING** — Select jumper 1 (JW1) for connecting alarm relay terminal (AL2) to 24 vac (R) or to remain as a dry contact (no connection). To connect AL2 to R, do not clip the jumper. To set as dry contact, clip the jumper.

**Complete C Control DIP Switches** — The C Control has one DIP switch block with five switches. See Fig. 11 and 13.

**PERFORMANCE MONITOR (PM)** — DIP switch 1 will enable or disable this feature. To enable the PM, set the switch to ON. To disable the PM, set the switch to OFF.

**STAGE 2** — DIP switch 2 will enable or disable compressor delay. Set DIP switch to OFF for stage 2 in which the compressor will have a 3-second delay before energizing.

**SWITCH 3 AND SWITCH 4** — Not used.

**FREEZE PROTECTION (FPI)** — DIP switch 5 is used to initiate 1 or 3 tries for the FPI fault. If there is water freeze

protection for the water coil then DIP switch 5 can be set to lock out on the FP1 fault after 1 try. ON = 1 try. OFF = 3 tries.

**Deluxe D Control Jumper Settings (See Fig. 12 and 14)**

**WATER COIL FREEZE PROTECTION (FP1) LIMIT SETTING** — Select jumper 3, (JW3-FP1 Low Temp) to choose FP1 temperature limit of 10 F or 30 F. To select 30 F as the temperature limit, DO NOT clip the jumper. To select 10 F as the limit, clip the jumper.

**ALARM RELAY SETTING** — Select jumper 4 (JW4-AL2 Dry) for connecting alarm relay terminal (AL2) to 24 vac (R) or to remain as a dry contact (no connection). To connect AL2 to R, do not clip the jumper. To set as dry contact, clip the jumper.

**LOW PRESSURE SETTING** — The D Control can be configured for Low Pressure Setting (LP). Select jumper 1 (JW1-LP Norm Open) for choosing between low pressure input normally opened or closed. To configure for normally closed operation, do not clip the jumper. To configure for normally open operation, clip the jumper.

**Deluxe D Control DIP Switches** — The D Control has 2 DIP switch blocks. Each DIP switch block has 8 switches and is labeled either S1 or S2 on the circuit board. See Fig. 12 and 14.

**DIP SWITCH BLOCK 1 (S1)** — This set of switches offers the following options for D Control configuration:

**Performance Monitor (PM)** — Set switch 1 to enable or disable performance monitor. To enable the PM, set the switch to ON. To disable the PM, set the switch to OFF.

**Compressor Relay Staging Operation** — Switch 2 will enable or disable compressor relay staging operation. The compressor relay can be set to turn on with stage 1 or stage 2 call from the thermostat. This setting is used with dual stage units (units with 2 compressors and 2 D controls) or in master/slave applications. In master/slave applications, each compressor and fan will stage according to its switch 2 setting. If switch is set to stage 2, the compressor will have a 3-second delay before energizing during stage 2 demand.

NOTE: If DIP switch is set for stage 2, the alarm relay will not cycle during Test mode.

**Heating/Cooling Thermostat Type** — Switch 3 provides selection of thermostat type. Heat pump or heat/cool thermostats can be selected. Select OFF for heat/cool thermostats. When in heat/cool mode, Y1 is used for cooling stage 1, Y2 is used for cooling stage 2, W1 is used for heating stage 1 and O/W2 is used for heating stage 2. Select ON for heat pump applications. In heat pump mode, Y1 used is for compressor stage 1, Y2 is used for compressor stage 2, W1 is used for heating stage 3 or emergency heat, and O/W2 is used for RV (heating or cooling) depending upon switch 4 setting.

**O/B Thermostat Type** — Switch 4 provides selection for heat pump O/B thermostats. O is cooling output. B is heating output. Select ON for heat pumps with O output. Select OFF for heat pumps with B output.

**Dehumidification Fan Mode** — Switch 5 provides selection of normal or dehumidification fan mode. Select OFF for dehumidification mode. The fan speed relay will remain OFF during cooling stage 2. Select ON for normal mode. The fan speed relay will turn on during cooling stage 2 in normal mode.

**Switch 6** — Not used.

**Boilerless Operation** — Switch 7 provides selection of boilerless operation and works in conjunction with switch 8. In boilerless operation mode, only the compressor is used for heating when FP1 is above the boilerless changeover temperature set by switch 8 below. Select ON for normal operation or select OFF for boilerless operation.

**Boilerless Changeover Temperature** — Switch 8 on S1 provides selection of boilerless changeover temperature set point. Select OFF for set point of 50 F or select ON for set point of 40 F.

If switch 8 is set for 50 F, then the compressor will be used for heating as long as the FP1 is above 50 F. The compressor will not be used for heating when the FP1 is below 50 F and the compressor will operate in emergency heat mode, staging on EH1 and EH2 to provide heat. If a thermal switch is being used instead of the FP1 thermistor, only the compressor will be used for heating mode when the FP1 terminals are closed. If the FP1 terminals are open, the compressor is not used and the control goes into emergency heat mode.

**DIP SWITCH BLOCK 2 (S2)** — This set of DIP switches is used to configure accessory relay options.

**Switches 1 to 3** — These DIP switches provide selection of Accessory 1 relay options. See Table 6 for DIP switch combinations.

**Switches 4 to 6** — These DIP switches provide selection of Accessory 2 relay options. See Table 7 for DIP switch combinations.

**Auto Dehumidification Mode or High Fan Mode** — Switch 7 provides selection of auto dehumidification fan mode or high fan mode. In auto dehumidification fan mode the fan speed relay will remain off during cooling stage 2 if terminal H is active. In high fan mode, the fan enable and fan speed relays will turn on when terminal H is active. Set the switch to ON for auto dehumidification fan mode or to OFF for high fan mode.

**Switch 8** — Not used.

**Table 6 — DIP Switch Block S2 — Accessory 1 Relay Options**

ACCESSORY 1 RELAY OPTIONS	DIP SWITCH POSITION		
	1	2	3
Digital NSB	Off	On	On
Water Valve — Slow Opening	On	Off	On

LEGEND

NSB — Night Setback

NOTE: All other DIP switch combinations are invalid.

**Table 7 — DIP Switch Block S2 — Accessory 2 Relay Options**

ACCESSORY 2 RELAY OPTIONS	DIP SWITCH POSITION		
	4	5	6
Digital NSB	Off	On	On
Water Valve — Slow Opening	On	Off	On

LEGEND

NSB — Night Setback

NOTE: All other switch combinations are invalid.

**Deluxe D Control Accessory Relay Configurations** — The following accessory relay settings are applicable for D control only:

**CYCLE WITH COMPRESSOR** — In this configuration, the relay will be ON any time the Compressor relay is on.

**DIGITAL NIGHT SETBACK (NSB)** — In this configuration, the relay will be ON if the NSB input is connected to ground C.

NOTE: If there are no relays configured for digital NSB, then the NSB and OVR inputs are automatically configured for mechanical operation.

**MECHANICAL NIGHT SETBACK** — When NSB input is connected to ground C, all thermostat inputs are ignored. A thermostat setback heating call will then be connected to the

OVR input. If OVR input becomes active, then the D control will enter Night Low Limit (NLL) staged heating mode. The NLL staged heating mode will then provide heating during the NSB period.

**WATER VALVE (SLOW OPENING)** — If relay is configured for Water Valve (slow opening), the relay will start 60 seconds prior to starting compressor relay.

**CAUTION**

To avoid equipment damage, DO NOT leave system filled in a building without heat during the winter unless anti-freeze is added to system water. Condenser coils never fully drain by themselves and will freeze unless winterized with antifreeze.

**START-UP**

Use the procedure outlined below to initiate proper unit start-up:

**NOTE: This equipment is designed for indoor installation ONLY.**

**WARNING**

When the disconnect switch is closed, high voltage is present in some areas of the electrical panel. Exercise caution when working with the energized equipment.

1. Adjust all valves to the full open position and turn on the line power to all heat pump units.
2. Operate each unit in the Cooling mode first. Room temperature should be in the normal range (i.e., approximately 50 to 80 F dry bulb). Loop water temperature entering the heat pumps should be at least 40 F but not in excess of 110 F. Refer to Table 4 for more specific information on the operating parameters of units.

**NOTE: Three factors determine the operating limits of a unit: (1) return-air temperature, (2) water temperature and (3) ambient temperature. Whenever any one of these factors is at a minimum or maximum level, the other two factors must be at normal levels to ensure proper unit operation. Flow rates must be at nominal ARI/ISO/ASHRAE 13256-1 standards.**

**Unit Start-Up/Cooling**

1. Turn the unit thermostat to the cooling position and turn the fan speed switch to "HI." If the unit has an optional MCO thermostat, set the selector switch to Cool. Both the fan and compressor should run.
2. Check for cool air delivery at unit grille 15 minutes after the unit has begun operating. List the identification number of any machines that do not function at this time.
3. Check the elevation and cleanliness of the condensate lines; any dripping could be a sign of a blocked line.
4. Select low fan speed. Airflow should decrease and compressor should operate.
5. Slowly turn thermostat toward warmer position. Both fan and compressor should shut off when thermostat set point equals room temperature. Room temperature must be below 90 F for unit to shut off.
6. Operate each heat pump in the heating cycle immediately after checking cooling cycle operation. A time delay will prevent the compressor from re-starting for approximately 5 minutes.

**Operating Limits**

**ENVIRONMENT** — This equipment is designed for indoor installation ONLY.

**POWER SUPPLY** — A voltage variation of  $\pm 10\%$  of name-plate utilization voltage is acceptable.

**50KQL UNIT STARTING CONDITIONS** — The 50KQL units will start and operate at an ambient temperature of 50 F with entering-air temperature at 50 F, entering water at 60 F, and with both air and water at the flow rates used in the ARI/ISO/ASHRAE Standard 13256-1 rating test, for initial start-up in winter.

**NOTE: These operating limits are not normal or continuous operating conditions. It is assumed that such a start-up is for the purpose of bringing the building space up to occupancy temperature.**

**Unit Start-Up/Heating**

1. Adjust the unit thermostat to the warmest setting and turn the fan speed switch to “HI.” If the unit has an optional MCO thermostat, set the selector switch to Heat. The blower should start immediately and after the time delay is complete, the compressor will start.
2. Once the unit has begun to run, check for warm air delivery at the unit grille. Again, the installing contractor must list the serial number of any machine that does not function.
3. Log the unit operating conditions at initial start-up for each unit to establish a permanent operating record.
4. Select low fan speed. Airflow should decrease and compressor should continue to operate.
5. Slowly turn thermostat toward cooler position. Both fan and compressor should shut off when thermostat set point equals room temperature. Room temperature must be above 65 F for unit to shut off.

**Flow Regulation** — Flow regulation can be accomplished by two methods. Most water control valves have a flow adjustment built into the valve. Determine the flow rate by measuring the pressure drop through the unit heat exchanger. See Table 8. Adjust the water control valve until the flow of 1.5 to 2 gpm per ton cooling is achieved. Since the pressure constantly varies, two pressure gages may be needed in some applications.

An alternative method for regulating flow is to install a flow control device. These devices are typically an orifice of plastic material mounted on the outlet of the water control valve, designed to allow a specified flow rate. Occasionally these valves produce a velocity noise that can be reduced by applying some back pressure. To accomplish this, slightly close the leaving isolation valve of the well water setup.

**⚠ CAUTION**

DO NOT use “Stop Leak” or any similar chemical agent in this system. Addition of these chemicals to the loop water will foul the system and inhibit unit operation.

**Antifreeze** — In areas where entering loop temperatures drop below 40 F or where piping will be routed through areas subject to freezing, antifreeze is needed.

Alcohols and glycols are commonly used as antifreeze agents. Freeze protection should be maintained to 15 F below the lowest expected entering loop temperature. For example, if the lowest expected entering loop temperature is 30 F, the leaving loop temperature would be 22 to 25 F. Therefore, the freeze protection should be at 15 F (30 F – 15 F) = 15 F.

**IMPORTANT:** All alcohols should be pre-mixed and pumped from a reservoir outside of the building or introduced under water level to prevent alcohols from fuming.

Calculate the total volume of fluid in the piping system. Table 9. Use the percentage by volume in Table 10 to determine the amount of antifreeze to use. Antifreeze concentration should be checked from a well mixed sample using a hydrometer to measure specific gravity.

**FREEZE PROTECTION SELECTION** — The 30 F FP1 factory setting (water) should be used to avoid freeze damage to the unit.

Once antifreeze is selected, the JW3 jumper (FP1) should be clipped on the control to select the low temperature (antifreeze 10 F) set point to avoid nuisance faults.

**Cooling Tower/Boiler Systems** — These systems typically use a common loop maintained at 60 to 90 F. Carrier recommends using a closed circuit evaporative cooling tower with a secondary heat exchanger between the tower and the water loop. If an open type cooling tower is used continuously, chemical treatment and filtering will be necessary.

**Ground Coupled, Closed Loop and Plateframe Heat Exchanger Well Systems** — These systems allow water temperatures from 30 to 110 F. The external loop field is divided up into 2 in. polyethylene supply and return lines. Each line has valves connected in such a way that upon system start-up, each line can be isolated for flushing using only the system pumps. Air separation should be located in the piping system prior to the fluid re-entering the loop field.

**Table 8 — Coaxial Water Pressure Drop**

UNIT 50KQL	FLOW (GPM)	PRESSURE DROP (ft wg)							
		30 F		50 F		70 F		90 F	
		Without Motorized Valve	With Cv = 2.9 MOPD = 125 psi	Without Motorized Valve	With Cv = 2.9 MOPD = 125 psi	Without Motorized Valve	With Cv = 2.9 MOPD = 125 psi	Without Motorized Valve	With Cv = 2.9 MOPD = 125 psi
07	1.0	1.4	1.6	0.9	1.0	0.7	0.9	0.6	0.7
	1.4	2.2	2.4	1.4	1.6	1.2	1.4	1.0	1.2
	1.9	3.3	3.7	2.0	2.5	1.8	2.2	1.4	1.9
09	1.3	1.8	2.0	1.3	1.5	1.2	1.3	1.0	1.2
	1.9	3.2	3.6	2.5	2.9	2.2	2.7	2.0	2.4
	2.5	5.0	5.8	3.9	4.6	3.5	4.2	3.0	3.8
12	1.6	1.8	6.5	1.6	6.5	1.4	6.5	1.3	6.5
	2.3	3.3	11.4	2.9	11.4	2.6	11.4	2.3	11.4
	3.1	5.3	19.6	4.5	19.6	4.1	19.6	3.7	19.6
15	1.8	1.2	1.6	1.2	1.6	1.1	1.5	1.0	1.4
	2.7	2.6	3.4	2.2	3.1	2.0	2.9	1.9	2.7
	3.6	4.2	5.7	3.5	5.0	3.2	4.8	3.0	4.5
19	2.4	2.1	2.8	2.0	2.6	1.8	2.4	1.6	2.3
	3.6	4.2	5.8	3.7	5.2	3.3	4.9	3.0	4.6
	4.8	6.8	9.6	6.0	8.8	5.5	8.2	4.9	7.7

**LEGEND**

- Cv** — Flow Coefficient
- MOPD** — Maximum Operating Pressure Differential

**Table 9 — Approximate Fluid Volume (gal) per 100 ft of Pipe**

PIPE	DIAMETER (in.)	VOLUME (gal.)
Copper	1	4.1
	1.25	6.4
	1.5	9.2
Rubber Hose	1	3.9
Polyethylene	3/4 IPS SDR11	2.8
	1 IPS SDR11	4.5
	1 1/4 IPS SDR11	8.0
	1 1/2 IPS SDR11	10.9
	2 IPS SDR11	18.0
	1 1/4 IPS SCH40	8.3
	1 1/2 IPS SCH40	10.9
2 IPS SCH40	17.0	

LEGEND

- IPS — Internal Pipe Size
- SCH — Schedule
- SDR — Standard Dimensional Ratio

NOTE: Volume of heat exchanger is approximately 1.0 gallon.

**Table 10 — Antifreeze Percentages by Volume**

ANTIFREEZE	MINIMUM TEMPERATURE FOR FREEZE PROTECTION (F)			
	10	15	20	25
Methanol (%)	25	21	16	10
100% USP Food Grade Propylene Glycol (%)	38	30	22	15

**OPERATION**

**Power Up Mode** — The unit will not operate until all the inputs, terminals and safety controls are checked for normal operation.

NOTE: The compressor will have a 5-minute anti-short cycle delay upon power up.

**Units with Aquazone™ Complete C Control**

**STANDBY** — Y and W terminals are not active in Standby mode, however the O and G terminals may be active, depending on the application. The compressor will be off.

**COOLING** — Y and O terminals are active in Cooling mode. After power up, the first call to the compressor will initiate a 5 to 80-second random start delay and a 5-minute anti-short cycle protection time delay. After both delays are complete, the compressor is energized.

NOTE: On all subsequent compressor calls the random start delay is omitted.

**HEATING STAGE 1** — Terminal Y is active in heating stage 1. After power up, the first call to the compressor will initiate a 5 to 80-second random start delay and a 5-minute anti-short cycle protection time delay. After both delays are complete, the compressor is energized.

NOTE: On all subsequent compressor calls the random start delay is omitted.

**HEATING STAGE 2** — To enter Stage 2 mode, terminal W is active (Y is already active). Also, the G terminal must be active or the W terminal is disregarded. The compressor relay will remain on and EH1 (emergency heat) is immediately turned on. EH2 will turn on after 10 minutes of continual stage 2 demand.

NOTE: EH2 will not turn on (or if on, will turn off) if FP1 (freeze protection) temperature is greater than 45 F and FP2 is greater than 110 F.

**EMERGENCY HEAT** — In Emergency Heat (EH) mode, terminal W is active while terminal Y is not. Terminal G must be active or the W terminal is disregarded. EH1 is immediately turned on. EH2 will turn on after 5 minutes of continuous emergency heat demand.

**Units with Aquazone Deluxe D Control**

**STANDBY/FAN ONLY** — The compressor will be off. The Fan Enable, Fan Speed, and reversing valve (RV) relays will be on if inputs are present. If there is a Fan 1 demand, the Fan

Enable will immediately turn on. If there is a Fan 2 demand, the Fan Enable and Fan Speed will immediately turn on.

NOTE: DIP switch 5 on S1 does not have an effect upon Fan 1 and Fan 2 outputs.

**HEATING STAGE 1** — In Heating Stage 1 mode, the Fan Enable and Compressor relays are turned on immediately. Once the demand is removed, the relays are turned off and the control reverts to Standby mode. If there is a master/slave or dual compressor application, all compressor relays and related functions will operate per their associated DIP switch 2 setting on S1.

**HEATING STAGE 2** — In Heating Stage 2 mode, the Fan Enable and Compressor relays remain on. The Fan Speed relay is turned on immediately and turned off immediately once the demand is removed. The control reverts to Heating Stage 1 mode. If there is a master/slave or dual compressor application, all compressor relays and related functions will operate per their associated DIP switch 2 setting on S1.

**HEATING STAGE 3** — In Heating Stage 3 mode, the Fan Enable, Fan Speed and Compressor relays remain on. The EH1 output is turned on immediately. With continuing Heat Stage 3 demand, EH2 will turn on after 10 minutes. EH1 and EH2 are turned off immediately when the Heating Stage 3 demand is removed. The control reverts to Heating Stage 2 mode.

Output EH2 will be off if FP1's temperature is greater than 45 F AND FP2 (when shorted) is greater than 110 F during Heating Stage 3 mode. This condition will have a 30-second recognition time. Also, during Heating Stage 3 mode, EH1, EH2, Fan Enable, and Fan Speed will be ON if G input is not active.

**EMERGENCY HEAT** — In Emergency Heat mode, the Fan Enable and Fan Speed relays are turned on. The EH1 output is turned on immediately. With continuing Emergency Heat demand, EH2 will turn on after 5 minutes. Fan Enable and Fan Speed relays are turned off after a 60-second delay. The control reverts to Standby mode.

Output EH1, EH2, Fan Enable, and Fan Speed will be ON if the G input is not active during Emergency Heat mode.

**COOLING STAGE 1** — In Cooling Stage 1 mode, the Fan Enable, compressor and RV relays are turned on immediately. If configured as stage 2 (DIP switch set to OFF) then the compressor and fan will not turn on until there is a stage 2 demand. The Fan Enable and compressor relays are turned off immediately when the Cooling Stage 1 demand is removed. The control reverts to Standby mode. The RV relay remains on until there is a heating demand. If there is a master/slave or dual compressor application, all compressor relays and related functions will track with their associated DIP switch 2 on S1.

**COOLING STAGE 2** — In Cooling Stage 2 mode, the Fan Enable, compressor and RV relays remain on. The Fan Speed relay is turned on immediately and turned off once the Cooling Stage 2 demand is removed. The control reverts to Cooling Stage 1 mode. If there is a master/slave or dual compressor application, all compressor relays and related functions will track with their associated DIP switch 2 on S1.

**NIGHT LOW LIMIT (NLL) STAGED HEATING** — In NLL staged Heating mode, the override (OVR) input becomes active and is recognized as a call for heating and the control will immediately go into a Heating Stage 1 mode. With an additional 30 minutes of NLL demand, the control will go into Heating Stage 2 mode. With another additional 30 minutes of NLL demand, the control will go into Heating Stage 3 mode.

**SYSTEM TEST**

System testing provides the ability to check the control operation. The control enters a 20-minute Test mode by momentarily shorting the test pins. All time delays are reduced by a factor of 15.

**Test Mode** — To enter Test mode on Complete C or Deluxe D controls, cycle the power 3 times within 60 seconds. The LED (light-emitting diode) will flash a code representing the last fault when entering the Test mode. The alarm relay will also power on and off during Test mode. See Tables 11-13. To exit Test mode, short the terminals for 3 seconds or cycle the power 3 times within 60 seconds.

NOTE: The Deluxe D control has a flashing code and alarm relay cycling code that will both have the same numerical label. For example, flashing code 1 will have an alarm relay cycling code 1. Code 1 indicates the control has not faulted since the last power off to power on sequence.

**Retry Mode** — In Retry mode, the status LED will start to flash slowly to signal that the control is trying to recover from an input fault. The control will stage off the outputs and try to again satisfy the thermostat used to terminal Y. Once the thermostat input calls are satisfied, the control will continue normal operation.

NOTE: If 3 consecutive faults occur without satisfying the thermostat input call to terminal Y, the control will go into lockout mode. The last fault causing the lockout is stored in memory and can be viewed by entering Test mode.

**Table 11 — Complete C Control Current LED Status and Alarm Relay Operations**

LED STATUS	DESCRIPTION OF OPERATION	ALARM RELAY
On	Normal Mode	Open
	Normal Mode with PM Warning	Cycle (Closed 5 sec. Open 25 sec.)
Off	C Control is non-functional	Open
Slow Flash	Fault Retry	Open
	Over/Under Voltage Shutdown	Open (Closed after 15 minutes)
Fast Flash	Lockout	Closed
Flashing Code 1	Test Mode — No fault in memory	Cycling Code 1
Flashing Code 2	Test Mode — HP Fault in memory	Cycling Code 2
Flashing Code 3	Test Mode — LP Fault in memory	Cycling Code 3
Flashing Code 4	Test Mode — FP1 Fault in memory	Cycling Code 4
Flashing Code 5	Test Mode — FP2 Fault in memory	Cycling Code 5
Flashing Code 6	Test Mode — CO Fault in memory	Cycling Code 6
Flashing Code 7	Test Mode — Over/Under shutdown in memory	Cycling Code 7
Flashing Code 8	Test Mode — PM in memory	Cycling Code 8
Flashing Code 9	Test Mode — FP1/FP2 swapped fault in memory	Cycling Code 9

LEGEND

- CO — Condensate Overflow
- FP — Freeze Protection
- HP — High Pressure
- LED — Light-Emitting Diode
- LP — Low Pressure
- PM — Performance Monitor

NOTES:

1. Slow flash is 1 flash every 2 seconds.
2. Fast flash is 2 flashes every 1 second.
3. EXAMPLE: "Flashing Code 2" is represented by 2 fast flashes followed by a 10-second pause. This sequence will repeat continually until the fault is cleared.

**Table 12 — Complete C Control LED Code and Fault Descriptions**

LED CODE	FAULT	DESCRIPTION
1	No fault in memory	There has been no fault since the last power-down to power-up sequence
2	High-Pressure Switch	HP Open Instantly
3	Low-Pressure Switch	LP open for 30 continuous seconds before or during a call (bypassed for first 60 seconds)
4	Freeze Protection Coax — FP1	FP1 below Temp limit for 30 continuous seconds (bypassed for first 60 seconds of operation)
5	Freeze Protection Air Coil — FP2	FP2 below Temp limit for 30 continuous seconds (bypassed for first 60 seconds of operation)
6	Condensate overflow	Sense overflow (grounded) for 30 continuous seconds
7 (Autoreset)	Over/Under Voltage Shutdown	"R" power supply is <19VAC or >30VAC
8	PM Warning	Performance Monitor Warning has occurred.
9	FPI and FP2 Thermistors are swapped	FP1 temperature is higher than FP2 in heating/test mode, or FP2 temperature is higher than FP1 in cooling/test mode.

LEGEND

- CO — Condensate Overflow
- FP — Freeze Protection
- HP — High Pressure
- LED — Light-Emitting Diode
- LP — Low Pressure
- PM — Performance Monitor

**Aquazone™ Deluxe D Control LED Indicators** — There are 3 LED indicators on the D Control:

**STATUS LED** — Status LED indicates the current status or mode of the D control. The Status LED light is green.

**TEST LED** — Test LED will be activated any time the D control is in Test mode. The Test LED light is yellow.

**FAULT LED** — Fault LED light is red. The fault LED will always flash a code representing the last fault in memory. If there is no fault in memory, the fault LED will flash code 1 and appear as 1 fast flash alternating with a 10-second pause. See Table 13.

**Table 13 — Aquazone™ Deluxe D Control Current LED Status and Alarm Relay Operations**

DESCRIPTION	STATUS LED (Green)	TEST LED (Yellow)	FAULT LED (Red)	ALARM RELAY
Normal Mode	On	Off	Flash Last Fault Code in Memory	Open
Normal Mode with PM	On	Off	Flashing Code 8	Cycle (closed 5 sec, open 25 sec, ...)
D Control is non-functional	Off	Off	Off	Open
Test Mode	—	On	Flash Last Fault Code in Memory	Cycling Appropriate Code
Night Setback	Flashing Code 2	—	Flash Last Fault Code in Memory	—
ESD	Flashing Code 3	—	Flash Last Fault Code in Memory	—
Invalid T-stat Inputs	Flashing Code 4	—	Flash Last Fault Code in Memory	—
No Fault in Memory	On	Off	Flashing Code 1	Open
HP Fault	Slow Flash	Off	Flashing Code 2	Open
LP Fault	Slow Flash	Off	Flashing Code 3	Open
FP1 Fault	Slow Flash	Off	Flashing Code 4	Open
FP2 Fault	Slow Flash	Off	Flashing Code 5	Open
CO Fault	Slow Flash	Off	Flashing Code 6	Open
Over/Under Voltage	Slow Flash	Off	Flashing Code 7	Open (closed after 15 minutes)
HP Lockout	Fast Flash	Off	Flashing Code 2	Closed
LP Lockout	Fast Flash	Off	Flashing Code 3	Closed
FP1 Lockout	Fast Flash	Off	Flashing Code 4	Closed
FP2 Lockout	Fast Flash	Off	Flashing Code 5	Closed
CO Lockout	Fast Flash	Off	Flashing Code 6	Closed

LEGEND

<b>CO</b>	—	Condensate Overflow
<b>ESD</b>	—	Emergency Shutdown
<b>FP</b>	—	Freeze Protection
<b>HP</b>	—	High Pressure
<b>LED</b>	—	Light-Emitting Diode
<b>LP</b>	—	Low Pressure
<b>PM</b>	—	Performance Monitor

NOTES:

1. If there is no fault in memory, the Fault LED will flash code 1.
2. Codes will be displayed with a 10-second Fault LED pause.
3. Slow flash is 1 flash every 2 seconds.
4. Fast flash is 2 flashes every 1 second.
5. EXAMPLE: "Flashing Code 2" is represented by 2 fast flashes followed by a 10-second pause. This sequence will repeat continually until the fault is cleared.

## SERVICE

Perform the procedures outlined below periodically, as indicated.

**IMPORTANT:** When a compressor is removed from this unit, system refrigerant circuit oil will remain in the compressor. To avoid leakage of compressor oil, the refrigerant lines of the compressor must be sealed after it is removed.

**IMPORTANT:** All refrigerant discharged from this unit must be recovered without exception. Technicians must follow industry accepted guidelines and all local, state and federal statutes for the recovery and disposal of refrigerants.

**IMPORTANT:** To avoid the release of refrigerant into the atmosphere, the refrigerant circuit of this unit must only be serviced by technicians who meet local, state and federal proficiency requirements.

### ⚠ WARNING

To prevent injury or death due to electrical shock or contact with moving parts, open unit disconnect switch before servicing unit.

**Unit Inspection** — Visually inspect the unit at least once a month. Pay special attention to hose assemblies. Repair any leaks and replace deteriorated hoses immediately. Note any signs of deterioration or cracking.

**System Flushing** — Properly clean and flush system periodically. Refer to Pre-Start-Up, System Cleaning and Flushing section.

**Water Coil** — Keep air out of the water coil. Check open loop systems to be sure the well head is not allowing air to infiltrate the water line. Always keep lines airtight.

Inspect heat exchangers regularly and clean more frequently if the unit is located in a “dirty” environment. The heat exchanger should be kept full of water at all times. Open loop systems should have an inverted P trap placed in the discharge line to keep water in the heat exchanger during off cycles. Closed loop systems must have a minimum of 15 psig during the summer and 40 psig during the winter.

Check P trap frequently for proper operation.

**FILTERS** — Inspect filters. Establish a regular maintenance schedule. Clean or replace filters frequently depending on need.

To remove the filter from the 50KQL unit, slide the filter out of its frame located in the return air opening at the bottom front of the unit. When re-installing the filter, use the slide-in rails of the filter frame to guide the filter into the proper position.

### ⚠ CAUTION

To avoid fouled machinery and extensive unit clean-up, DO NOT operate units without filters in place. DO NOT use equipment as a temporary heat source during construction.

**Refrigerant System** — Verify air and water flow rates are at proper levels before servicing. To maintain sealed circuitry integrity, do not install service gages unless unit operation appears abnormal.

**Condenser Cleaning** — Water-cooled condensers may require cleaning of scale (water deposits) due to improperly maintained closed-loop water systems. Open water tower

systems may require removal of sludge build-up due to induced contaminants.

Local water conditions may cause excessive fouling or pitting of tubes. Therefore, condenser tubes should be cleaned at least once a year, or more often if the water is contaminated.

Use standard coil cleaning procedures which are compatible with both the heat exchanger material and copper water lines. Generally, the more water flowing through the unit, the less chance for scaling, however flow rates over 3 gpm per ton can produce water (or debris) velocities that can erode the heat exchanger wall and ultimately produce leaks.

Proper water treatment can minimize tube fouling and pitting. If such conditions are anticipated, Carrier recommends water treatment analysis. Refer to the Carrier System Design Manual, Part 5, for general water conditioning information.

### ⚠ CAUTION

Follow all safety codes. Wear safety glasses and rubber gloves when using inhibited hydrochloric acid solution. Observe and follow acid manufacturer’s instructions.

Clean condensers with an inhibited hydrochloric acid solution. The acid can stain hands and clothing, damage concrete, and, without inhibitor, damage steel. Cover surroundings to guard against splashing. Vapors from vent pipe are not harmful, but take care to prevent liquid from being carried over by the gases.

Warm solution acts faster, but cold solution is just as effective if applied for a longer period.

**GRAVITY FLOW METHOD** — Do not add solution faster than vent can exhaust the generated gases.

When condenser is full, allow solution to remain overnight, then drain condenser and flush with clean water. Follow acid manufacturer’s instructions. See Fig. 19.

**FORCED CIRCULATION METHOD** — Fully open vent pipe when filling condenser. The vent may be closed when condenser is full and pump is operating. See Fig. 20.

Regulate flow to condenser with a supply line valve. If pump is a nonoverloading type, the valve may be fully closed while pump is running.

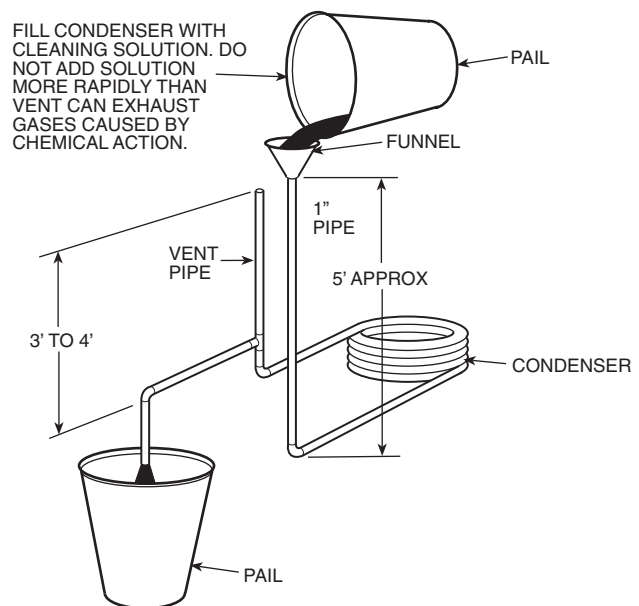
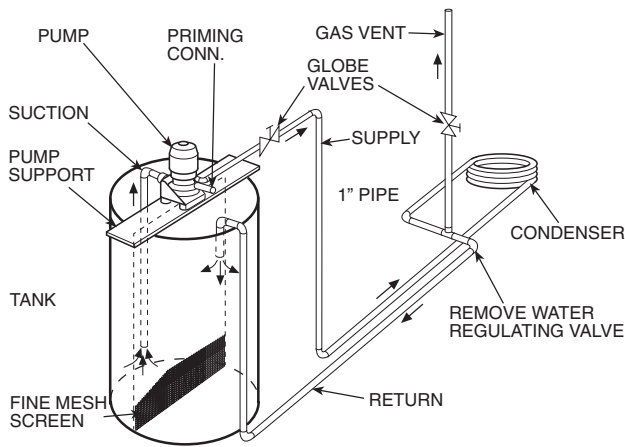

Fig. 19 — Gravity Flow Method



**Fig. 20 — Forced Circulation Method**

For average scale deposit, allow solution to remain in condenser overnight. For heavy scale deposit, allow 24 hours. Drain condenser and flush with clean water. Follow acid manufacturer's instructions.

**Condensate Pans** — Check condensate drain pans for algae growth every three months. If algae growth is apparent, consult a water treatment specialist for proper chemical treatment. The application of an algicide every three months will typically eliminate algae problems in most locations. Check condensate hose for leaks and blockage and correct any problems.

**Blower Motors** — All units have lubricated fan motors. BLOWER MOTORS SHOULD NEVER BE LUBRICATED UNLESS OBVIOUS, DRY OPERATION IS SUSPECTED. Periodic maintenance oiling is not recommended because it will result in dirt accumulating on excess oil and cause eventual motor failure. Conduct annual dry operation check and amperage check to ensure amp draw is no more than 10% greater than that indicated by serial plate data.

**Compressor** — Conduct an amperage check annually on the compressor and fan motor. Amperage draw should not exceed normal full load amps. Maintain a log of amperage to detect deterioration prior to component failure.

**Safety Control Reset** — The 50KQL heat pumps are furnished with high-pressure, low-pressure and low-temperature cutouts to prevent the machine from operating at abnormal conditions of temperature or water flow.

The contacts of the high-pressure control used on 50KQL units are designed to open at 376 psig and automatically re-close at 304 psig. The Complete C or Deluxe D control monitors this and other functions such as refrigerant temperatures and pressures and condensate overflow and will interrupt unit heating or cooling operation.

The machine must be reset manually. Reset is accomplished by pressing the STOP button and then pushing either HI HEAT, LOW HEAT, HI COOL or LO COOL to restart the unit in the desired mode of operation. (The 50KQL unit can also be reset by opening and closing the supply power disconnect switch.)

**NOTE: If the unit must be reset more than twice, check the unit for a dirty filter, abnormal entering water temperature, inadequate or excessive water flow, and internal malfunctions. If the unit continues to cut out, contact a trained service technician.**

## ⚠ WARNING

When replacing the compressor contactor or lockout relay in a unit with electromechanical controls, use only Carrier factory authorized parts. Substitution of other components may result in an inoperative safety circuit and may cause a hazardous condition.

**Checking System Charge** — Units are shipped with full operating charge. If recharging is necessary:

1. Insert thermometer bulb in insulating rubber sleeve on liquid line near filter drier. Use a digital thermometer for all temperature measurements. DO NOT use a mercury or dial-type thermometer.
2. Connect pressure gage to discharge line near compressor.
3. After unit conditions have stabilized, read head pressure on discharge line gage.

NOTE: Operate unit a minimum of 15 minutes before checking charge. From standard field-supplied Pressure-Temperature chart for R-22, find equivalent saturated condensing temperature.

4. Read liquid line temperature on thermometer, then subtract from bubble point temperature. The difference equals subcooling temperature.

## Refrigerant Charging

### ⚠ WARNING

To prevent personal injury, wear safety glasses and gloves when handling refrigerant. Do not overcharge system — this can cause compressor flooding.

NOTE: Do not vent or depressurize unit refrigerant to atmosphere. Remove and reclaim refrigerant following accepted practices.

## Air Coil Fan Motor Removal

### ⚠ CAUTION

Before attempting to remove fan motors or motor mounts, place a piece of plywood over evaporator coils to prevent coil damage.

Motor power wires need to be disconnected from motor terminals before motor is removed from unit.

1. Shut off unit main power supply.
2. Loosen bolts on mounting bracket so that fan belt can be removed.
3. Loosen and remove the 2 motor mounting bracket bolts on left side of bracket.
4. Slide motor/bracket assembly to extreme right and lift out through space between fan scroll and side frame. Rest motor on a high platform such as a step ladder. Do not allow motor to hang by its power wires.

## TROUBLESHOOTING

When troubleshooting problems with a WSHP, consider the following and refer to Table 14:

**Thermistor** — A thermistor may be required for single-phase units where starting the unit is a problem due to low voltage.

**Table 14 — Troubleshooting**

FAULT	HEATING	COOLING	POSSIBLE CAUSE	SOLUTION			
<b>Main Power Problems</b>	X	X	Green Status LED Off	Check line voltage circuit breaker and disconnect.			
				Check for line voltage between L1 and L2 on the contactor.			
				Check for 24 vac between R and C on controller.			
				Check primary/secondary voltage on transformer.			
<b>HP Fault — Code 2 High Pressure</b>		X	Reduced or no water flow in cooling	Check pump operation or valve operation/setting. Check water flow adjust to proper flow rate.			
		X	Water temperature out of range in cooling	Bring water temperature within design parameters.			
	X		Reduced or no airflow in heating	Check for dirty air filter and clean or replace.			
				Check fan motor operation and airflow restrictions.			
				Dirty air coil — construction dust etc. High external static.			
	X		Air temperature out of range in heating	Bring return-air temperature within design parameters.			
	X	X	Overcharged with refrigerant	Check superheat/subcooling vs. typical operating condition.			
X	X	Bad HP switch	Check switch continuity and operation. Replace.				
<b>LP Fault — Code 3 Low Pressure/Loss of Charge</b>	X	X	Insufficient charge	Check for refrigerant leaks.			
	X		Compressor pump down at start-up	Check charge and start-up water flow.			
<b>FP1 Fault — Code 4 Water Freeze Protection</b>	X		Reduced or no water flow in heating	Check pump operation or water valve operation/setting. Plugged strainer or filter. Clean or replace. Check water flow adjust to proper flow rate.			
		X	Inadequate antifreeze level	Check antifreeze density with hydrometer.			
		X	Improper freeze protect setting (10 F vs. 30 F)	Clip JW3 jumper for antifreeze (10 F) use.			
	X		Water temperature out of range	Bring water temperature within design parameters.			
	X	X	Bad thermistor	Check temperature and impedance correlation.			
	<b>FP2 Fault — Code 5 Air Coil Freeze Protection</b>		X	Reduced or no airflow in cooling	Check for dirty air filter and clean or replace. Check fan motor operation and airflow restrictions. High external static.		
		X	Air temperature out of range	Too much cold vent air. Bring entering-air temperature within design parameters.			
		X	Improper freeze protect setting (10 F vs. 30 F)	Normal airside applications will require 30 F only.			
X		X	Bad thermistor	Check temperature and impedance correlation.			
<b>Condensate Fault — Code 6</b>	X	X	Blocked drain	Check for blockage and clean drain.			
	X	X	Improper trap	Check trap dimensions and location ahead of vent.			
		X	Poor drainage	Check for piping slope away from unit. Check slope of unit toward outlet. Poor venting. Check vent location.			
				Moisture on sensor	Check for moisture shorting to air coil.		
<b>Over/Under Voltage — Code 7 (Auto Resetting)</b>	X	X	Under voltage	Check power supply and 24 vac voltage before and during operation. Check power supply wire size. Check compressor starting. Check 24 vac and unit transformer tap for correct power supply voltage.			
				X	X	Over voltage	Check power supply voltage and 24 vac before and during operation. Check 24 vac and unit transformer tap for correct power supply voltage.
	X			Heating mode FP2>125 F	Check for poor airflow or overcharged unit.		
<b>Performance Monitor — Code 8</b>		X	Cooling mode FP1>125 F OR FP2< 40 F	Check for poor water flow or airflow.			
<b>No Fault Code Shown</b>	X	X	Compressor overload	Check and replace if necessary.			
	X	X	Control board	Reset power and check operation.			
<b>Unit Short Cycles</b>	X	X	Dirty air filter	Check and clean air filter.			
	X	X	Unit in Test mode	Reset power or wait 20 minutes for auto exit.			
	X	X	Unit selection	Unit may be oversized for space. Check sizing for actual load of space.			
	X	X	Compressor overload	Check and replace if necessary.			
<b>Only Fan Runs</b>	X	X	Thermostat position	Ensure thermostat set for heating or cooling operation.			
	X	X	Unit locked out	Check for lockout codes. Reset power.			
	X	X	Compressor overload	Check compressor overload. Replace if necessary.			
	X	X	Thermostat wiring	Check Y and W wiring at heat pump. Jumper Y and R for compressor operation in Test mode.			

**LEGEND**

- FP — Freeze Protection
- HP — High Pressure
- LP — Low Pressure
- RV — Reversing Valve

**Table 14 — Troubleshooting (cont)**

FAULT	HEATING	COOLING	POSSIBLE CAUSE	SOLUTION
<b>Only Compressor Runs</b>	X	X	Thermostat wiring	Check G wiring at heat pump. Jumper G and R for fan operation.
	X	X	Fan motor relay	Jumper G and R for fan operation. Check for line voltage across BR contacts. Check fan power enable relay operation (if present).
	X	X	Fan motor	Check for line voltage at motor. Check capacitor.
	X	X	Thermostat wiring	Check Y and W wiring at heat pump. Jumper Y and R for compressor operation in Test mode.
<b>Unit Does Not Operate in Cooling</b>		X	Reversing valve	Set for cooling demand and check 24 VAC on RV coil and at control. If RV is stuck, run high pressure up by reducing water flow and while operating engage and disengage RV coil voltage to push valve.
		X	Thermostat setup	Check for 'O' RV setup not 'B'.
		X	Thermostat wiring	Check O wiring at heat pump. Jumper O and R for RV coil.
<b>Insufficient Capacity/ Not Cooling or Heating Properly</b>	X	X	Dirty filter	Replace or clean.
	X		Reduced or no airflow in heating	Check for dirty air filter and clean or replace. Check fan motor operation and airflow restrictions. High external static.
		X	Reduced or no airflow in cooling	Check for dirty air filter and clean or replace. Check fan motor operation and airflow restrictions. High external static.
	X	X	Leaky ductwork	Check supply and return air temperatures at the unit and at distant duct registers if significantly different, duct leaks are present.
	X	X	Low refrigerant charge	Check superheat and subcooling.
	X	X	Restricted metering device	Check superheat and subcooling. Replace.
		X	Defective reversing valve	Perform RV touch test.
	X	X	Thermostat improperly located	Check location and for air drafts behind thermostat.
	X	X	Unit undersized	Recheck loads and sizing check sensible cooling load and heat pump capacity.
	X	X	Scaling in water heat exchanger	Perform Scaling check and clean if necessary.
	X	X	Inlet water too hot or cold	Check load, loop sizing, loop backfill, ground moisture.
	<b>High Head Pressure</b>	X		Reduced or no airflow in heating
		X	Reduced or no water flow in cooling	Check pump operation or valve operation/setting. Check water flow adjust to proper flow rate.
		X	Inlet water too hot	Check load, loop sizing, loop backfill, ground moisture.
X			Air temperature out of range in heating	Bring return air temperature within design parameters.
		X	Scaling in water heat exchanger	Perform Scaling check and clean if necessary.
X		X	Unit overcharged	Check superheat and subcooling. Reweigh in charge.
X		X	Non-condensables in system	Vacuum system and reweigh in charge.
X		X	Restricted metering device	Check superheat and subcooling. Replace.
<b>Low Suction Pressure</b>	X		Reduced water flow in heating	Check pump operation or water valve operation/setting. Plugged strainer or filter. Clean or replace. Check water flow adjust to proper flow rate.
	X		Water temperature out of range	Bring water temperature within design parameters.
		X	Reduced airflow in cooling	Check for dirty air filter and clean or replace. Check fan motor operation and airflow restrictions. High external static.
		X	Air temperature out of range	Too much cold vent air. Bring entering air temperature within design parameters.
	X	X	Insufficient charge	Check for refrigerant leaks.
<b>Low Discharge Air Temperature in Heating</b>	X		Too high airflow	Check blower.
	X		Poor performance	See 'Insufficient Capacity'.
<b>High Humidity</b>		X	Too high airflow	Check blower.
		X	Unit oversized	Recheck loads and sizing check sensible cooling load and heat pump capacity.

LEGEND

- FP — Freeze Protection
- HP — High Pressure
- LP — Low Pressure
- RV — Reversing Valve



**50KQL UNIT  
START-UP CHECKLIST**

CUSTOMER: \_\_\_\_\_ JOB NAME: \_\_\_\_\_  
MODEL NO.: \_\_\_\_\_ SERIAL NO.: \_\_\_\_\_ DATE: \_\_\_\_\_

**I. PRE-START-UP**

DOES THE UNIT VOLTAGE CORRESPOND WITH THE SUPPLY VOLTAGE AVAILABLE? (Y/N) \_\_\_\_\_

HAVE THE POWER AND CONTROL WIRING CONNECTIONS BEEN MADE AND TERMINALS TIGHT? (Y/N) \_\_\_\_\_

HAVE WATER CONNECTIONS BEEN MADE AND IS FLUID AVAILABLE AT HEAT EXCHANGER? (Y/N) \_\_\_\_\_

HAS PUMP BEEN TURNED ON AND ARE ISOLATION VALVES OPEN? (Y/N) \_\_\_\_\_

HAS CONDENSATE CONNECTION BEEN MADE AND IS A TRAP INSTALLED? (Y/N) \_\_\_\_\_

IS AN AIR FILTER INSTALLED? (Y/N) \_\_\_\_\_

**II. START-UP**

IS FAN OPERATING WHEN COMPRESSOR OPERATES? (Y/N) \_\_\_\_\_

**UNIT VOLTAGE — COOLING OPERATION**

PHASE AB VOLTS \_\_\_\_\_

PHASE AB AMPS \_\_\_\_\_

**CONTROL VOLTAGE**

IS CONTROL VOLTAGE ABOVE 21.6 VOLTS? (Y/N) \_\_\_\_\_.

IF NOT, CHECK FOR PROPER TRANSFORMER CONNECTION.

**TEMPERATURES**

FILL IN THE ANALYSIS CHART ATTACHED.

COAXIAL HEAT EXCHANGER	COOLING CYCLE:						
	WATER IN	_____ F	WATER OUT	_____ F	_____ ft wg	_____ gpm	
	HEATING CYCLE:						
	WATER IN	_____ F	WATER OUT	_____ F	_____ ft wg	_____ gpm	
AIR COIL	COOLING CYCLE:						
	AIR IN	_____ F	AIR OUT	_____ F			
	HEATING CYCLE:						
	AIR IN	_____ F	AIR OUT	_____ F			

# HEATING CYCLE ANALYSIS

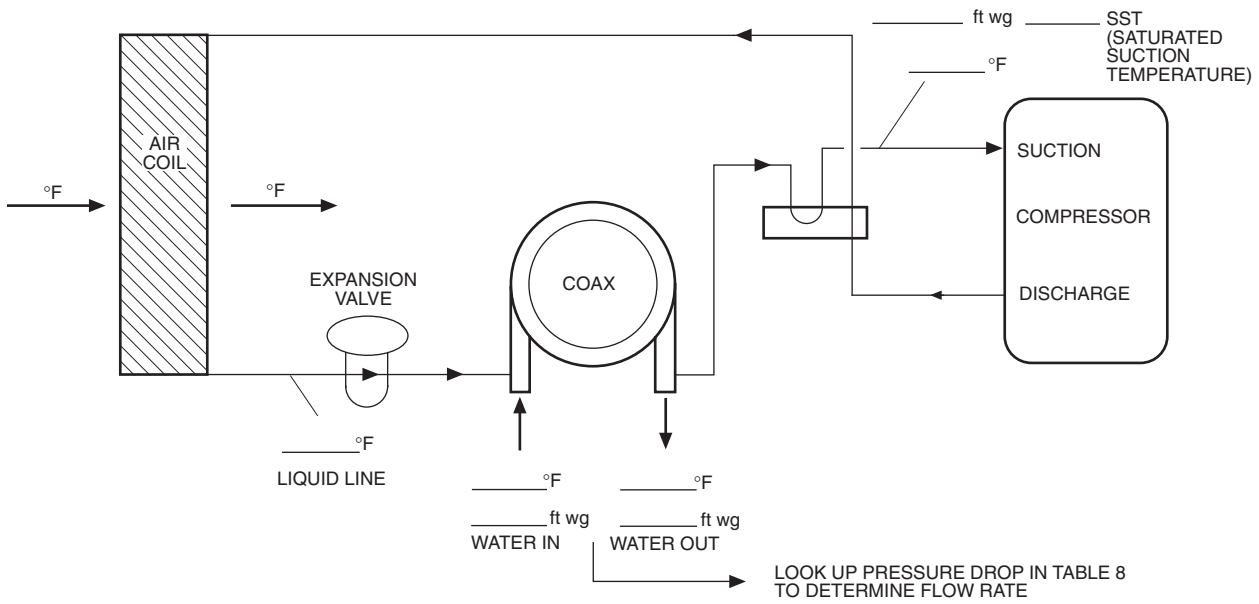

# COOLING CYCLE ANALYSIS

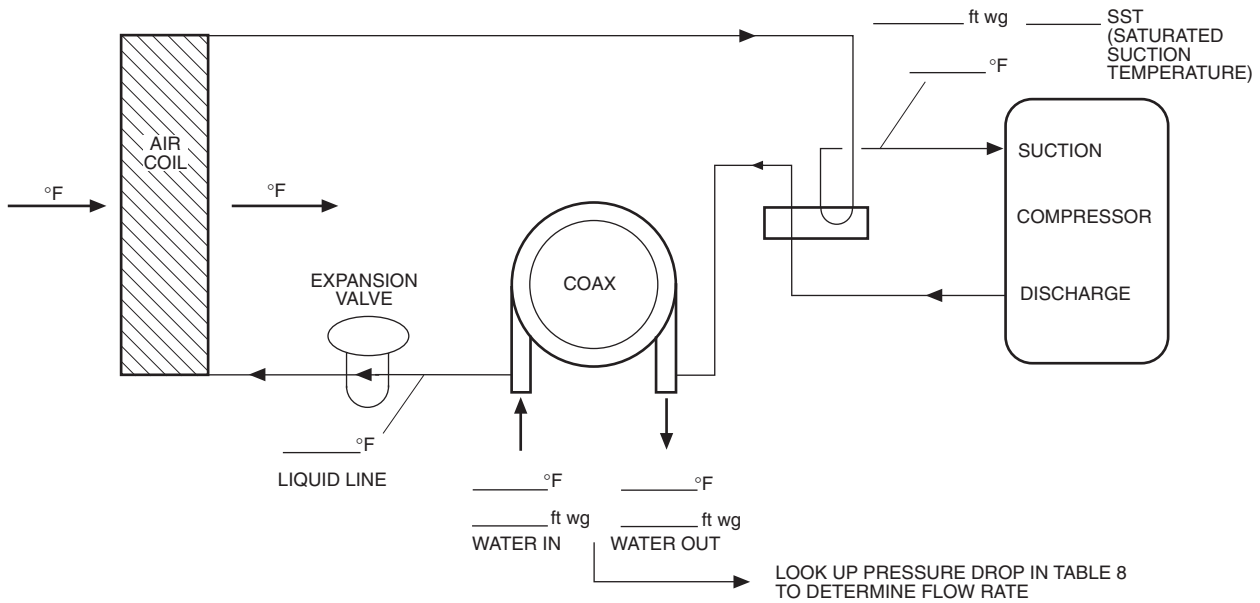

## HEAT OF EXTRACTION (ABSORPTION) OR HEAT OF REJECTION =

$$\text{FLOW RATE (gpm)} \times \text{TEMP. DIFF. (DEG F)} \times \text{FLUID FACTOR*} = \text{Btu/hr}$$

$$\text{SUPERHEAT} = \text{SUCTION TEMPERATURE} - \text{SATURATED SUCTION TEMPERATURE}$$

$$= \text{DEG F}$$

$$\text{SUBCOOLING} = \text{SATURATED CONDENSING TEMPERATURE} - \text{LIQUID LINE TEMPERATURE}$$

$$= \text{DEG F}$$

\*Use 500 for water, 485 for antifreeze.

CUT ALONG DOTTED LINE