



Product Data

OMNIZONE™ 50XCW06-24 Water-Cooled

Indoor Self-Contained Systems with PURON® Refrigerant (R-410A)

5 to 20 Nominal Tons

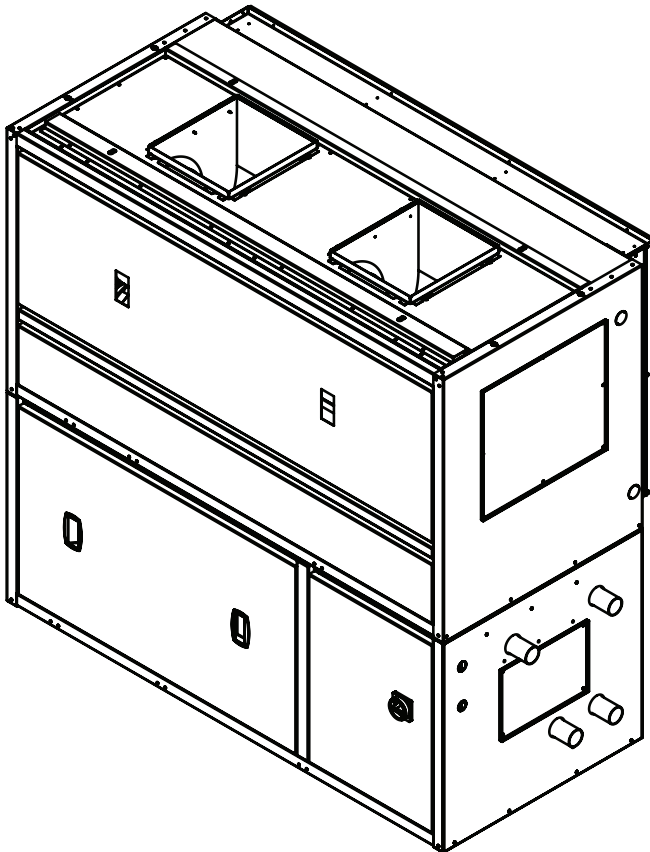

The 50XCW single-package water-cooled units with integral air-cooled condensers offer:

- Compact, durable, and attractive cabinet fits any working environment
- Ducted or free return with rear return connections with vertical supply air discharge
- High-efficiency cooling for commercial and industrial projects
- Puron® refrigerant (R-410A)

Features/Benefits

The Omnizone 50XCW units provide a practical and economical approach to comfort conditioning requirements for offices, factories, and other applications in existing buildings when indoor air-cooled condensers are required.

Design flexibility

The 50XCW water-cooled indoor packaged units are designed to provide the flexibility required in replacement, renovation, and new construction. Units are available in 6 sizes from 5 tons to 20 tons which meet the needs for cooling restaurants, retail stores, warehouses, offices, and building additions.



Features/Benefits (cont)



The compact footprint and service from the front of the units save valuable floor space in equipment rooms. Belt drive motors provide adequate static to overcome ducting and lower static losses. These units can be installed in the equipment room or the conditioned space and used for either ducted or free return applications. Unit supply air discharge is vertical.

Easy installation and maintenance

The units are completely pre-piped and wired at the factory to ensure time and money saving installation and service. Exterior access panels are easily removed to provide speedy inspection, and service work may be done from the front of the unit. Precision engineered parts translate to a quality built, reliable design that will operate efficiently, minimize service calls, and provide years of reliable operation.

Designed for customer satisfaction

Where space and styling are important considerations, 50XCW units are designed to exceed expectations. The high quality baked enamel finish will fit any environment attractively. These packaged systems provide the user with economy and product satisfaction in cooling, dehumidification, filtering, and air circulation.

Efficient design to increase savings

In order to provide an energy efficient HVAC solution, all 50XCW units have been designed to exceed the ASHRAE (American Society of Heating, Refrigerating and Air Conditioning Engineers) 90.1 (2010) guidelines.

Special features for outstanding performance

- Attractive, high-impact polystyrene air inlet grilles (sizes 06-14 only) enhance unit appearance, while also covering the filter opening.
- High-efficiency scroll compressors deliver quiet, reliable cooling capacity. Compressor motor protection is assured by quick-acting, internal sensing elements that prevent trouble before it starts.
- High-efficiency, brazed-plate condensers provide maximum exposed heat transfer surface for

greater heat rejection with less water, and can operate at up to 400 psig working pressure.

- Space-saver slab type evaporator and condenser coils use advanced heat transfer technology and provide peak heat transfer efficiency with large coil face area. Fins are mechanically bonded to nonferrous, seamless tubing for efficient leak-free operation.
- Quiet fan performance moves large volumes of indoor air. Compact housing and specially designed discharge air section provide superior air handling capacity.
- Convenient front access electrical control center contains all factory pre-wired control devices.
- A stainless steel, sloped, condensate pan is standard. As a result of this new design, the coil is easily accessed for cleaning.
- The cabinets are constructed of galvanized steel, bonderized, and coated on all external surfaces with a baked enamel finish. The paint finish is nonchalking and is capable of withstanding ASTM (American Society for Testing and Materials) Standard No. B117 500-hour salt spray test.
- Choose between a full line of room-mounted thermostats.

- Full compressor protection is assured by several devices, including current-sensing lockout relay(s), anti-short cycle control, and high and low-pressurestats. These devices lock out the compressor(s) under abnormal operating conditions to prevent compressor damage and ensure long life.
- The 50XCW units are covered by a standard limited 5-year warranty on the compressor and a standard limited one-year warranty on all other parts.
- Easy to understand and operate controls provide a virtually mistake-proof control operation.
- All motors are protected against single-phasing conditions.
- Units are built in an ISO 9001:2000 (International Standards Organization) certified manufacturing facility, and are fully run-tested.

Environmentally sound

Carrier's Puron® refrigerant (R-410A) enables you to make an environmentally responsible decision. Puron refrigerant (R-410A) is an HFC refrigerant that does not contain chlorine that is damaging to the stratospheric ozone layer. Puron refrigerant (R-410A) is unaffected by the Montreal Protocol. Puron refrigerant (R-410A) is a safe, efficient and environmentally sound refrigerant for the future.

Table of contents

| | Page |
|---------------------------------------|-------|
| Features/Benefits | 1,2 |
| Model Number Nomenclature | 3 |
| AHRI Capacity Ratings | 3 |
| Physical Data | 4 |
| Field-Installed Accessories | 4 |
| Dimensions | 5-15 |
| Selection Procedure | 15 |
| Performance Data | 16-33 |
| Electrical Data | 34,35 |
| Typical Wiring Schematic | 36,37 |
| Controls | 38 |
| Typical Piping and Wiring | 39 |
| Application Data | 40 |
| Guide Specifications | 41,42 |

Model number nomenclature



50XC W 24 A A - G 5 A A - 0 AA

50XC – OMNIZONE™ Indoor Packaged Unit

Condenser Option
W – Water-Cooled

Unit Size – Nominal Tons
06 – 5 14 – 12
08 – 7.5 16 – 15
12 – 10 24 – 20

Water Connections/Discharge Air Options
A – Right Hand, Vertical Discharge, Ducted
E – Right Hand, Horizontal Discharge, Ducted

Heating Coil Options
A – No Factory Installed Heating Coil

Evaporator Fan Speed
Set by selection program

Factory-Installed Options Code
See codes in unit price pages

Design Revision Level
0 – Original Release

Reserved for later use

Condenser Coil Options

A – No Low Ambient Option, No Service Valve, No Strainer

Control Options

A – Standard Controls

Voltage Options

1 – 575-3-60
5 – 208/230-3-60
6 – 460-3-60

Evaporator Motor Hp Options

B – 1/2 Hp Motor F – 2 Hp Motor
C – 3/4 Hp Motor G – 3 Hp Motor
D – 1 Hp Motor H – 5 Hp Motor
E – 1 1/2 Hp Motor J – 7 1/2 Hp Motor

AHRI* capacity ratings

| UNIT 50XCW | NOMINAL TONS | EVAPORATOR CFM | NET COOLING (Btuh) | TOTAL kW | EER | IEER |
|---------------|-----------------|-------------------|-----------------------|-------------|------|------|
| 06 | 5 | 1875 | 66,000 | 5.0 | 13.3 | 13.7 |
| 08 | 7½ | 2625 | 78,000 | 6.5 | 12.0 | 13.5 |
| 12 | 10 | 3500 | 134,000 | 9.2 | 14.6 | 17.2 |
| 14 | 12½ | 4200 | 138,000 | 8.6 | 16.1 | 15.6 |
| 16 | 15 | 5250 | 176,000 | 11.4 | 15.4 | 18.6 |
| 24 | 20 | 7000 | 242,000 | 17.9 | 13.5 | 14.6 |

LEGEND

EER — Energy Efficiency Ratio
IEER — Integrated Energy Efficiency Ratio

*AHRI — Air Conditioning, Heating, and Refrigeration Institute.

NOTE: Unit is tested in accordance with ARHI standard 340/360.



Physical data



| UNIT 50XCW | 06 | 08 | 12 | 14 | 16 | 24 |
|------------------------------------|--|--------------|--------------|----------------------------|----------------------------|----------------------------|
| NOMINAL CAPACITY (tons) | 5 | 7.5 | 10 | 12 | 15 | 20 |
| UNIT OPERATING WEIGHT (lb) | 642 | 824 | 1026 | 1119 | 1285 | 1712 |
| COMPRESSOR | Scroll | | | | | |
| Qty | 1 | 1 | 2 | 2 | 2 | 2 |
| Steps of Control | 1 | 1 | 2 | 2 | 2 | 2 |
| Operating Charge R-410A (lb) | 5.8 | 8.5 | 3.9 / 4.0 | 5.3 / 5.5 | 7.4 / 7.6 | 11.9 / 10.6 |
| Water Volume (Gal) | 7.7 | 7.7 | 16.9 | 21.9 | 32.8 | 32.8 |
| EVAPORATOR FAN | Adjustable, Belt-Drive, Centrifugal | | | | | |
| Nominal Cfm | 1750 | 2625 | 3500 | 4375 | 5250 | 7500 |
| Cfm Range | 1500 to 2500 | 2250 to 3750 | 3000 to 5000 | 3600 to 6000 | 4500 to 7500 | 6000 to 10000 |
| Available Static (in. wg) | 0 - 1.6 | 0 - 1.6 | 0 - 1.6 | 0 - 1.6 | 0 - 1.6 | 0 - 1.6 |
| Evaporator Fan Size | 110-10R | 110-10R | 120-9R | 120-9R | 120-9R | 120-11R |
| Number of Evaporator Fans | 1 | 2 | 2 | 2 | 3 | 3 |
| Standard Speed Range (Rpm) | 576 - 782 | 712 - 949 | 656 - 875 | 712 - 949 | 689 - 918 | 762 - 931 |
| Max. Allowable Rpm | 1600 | 1700 | 1700 | 1700 | 1700 | 1700 |
| Belt Type | A48 | BX41 | BX48 | BX47 | BX47 | BX60 |
| Fan Pulley (Type) | AK89 | BK65 | BK70 | BK65 | BK67 | BK95 |
| Motor Pulley (Type) | 1VL44 | 1VP34 | 1VP34 | 1VP34 | 1VP34 | 1VP50 |
| Std HP | 0.5 | 1 | 1 | 1.5 | 1.5 | 3 |
| HP Range | .5 - 2 | 1 - 2 | 1 - 3 | 1.5 - 5 | 1.5 - 5 | 3 - 7.5 |
| Fan Shaft Size (in.) | 0.75 | 1 | 1 | 1 | 1.1875 | 1.1875 |
| Motor Shaft Size (in.) | 0.625 | 0.875 | 0.875 | 0.875 | 0.875 | 1.125 |
| Center Distance (in.) - Vertical | 15.3 | 15.3 | 18.1 | 18.1 | 18.1 | 21.3 |
| Center Distance (in.) - Horizontal | N/A | N/A | 15.5 | 13.0 | 15.7 | 18.1 |
| EVAPORATOR COIL | ³ / ₈ -in. OD, Enhanced Copper Tube, Aluminum Fins | | | | | |
| Quantity Rows ... Fin/in. | 4...12 | 4...12 | 5...12 | 5...12 | 5...12 | 5...12 |
| Fin Block Size (H x L) (in.) | 28 x 34 | 28 x 46 | 32 x 60 | 32 x 60 | 32 x 80 | 36 x 80 |
| Face Area (sq ft) | 6.6 | 8.9 | 13.3 | 13.3 | 17.8 | 20.0 |
| RETURN AIR FILTERS | | | | | | |
| Std 1 in., throwaway | (2) 25 x 25 | (2) 25 x 25 | (8) 16 x 16 | (8) 16 x 16 (2) 16 x 20 | (8) 16 x 16 (2) 16 x 20 | (4) 18 x 18 (4) 18 x 24 |
| CONDENSER HEAT EXCHANGER | C5-XP | C7.5-XP | C5-XP | C7.5-XP | C7.5-XP | C-10XP |
| Number of Condensers | 1 | 1 | 2 | 2 | 2 | 2 |
| Nominal GPM | 15 | 23 | 30 | 38 | 45 | 60 |
| GPM range | 10 - 20 | 15 - 30 | 20 - 40 | 25 - 50 | 30 - 60 | 40 - 80 |
| Water Connection Size (OD) (in.) | 1.625 | 1.625 | 2.125 | 2.125 | 2.625 | 2.625 |
| HIGH PRESSURE SWITCH | Opens at 595 ± 10 psig; Closes at 443 ± 15 psig | | | | | |
| LOW PRESSURE SWITCH | Opens at 53 ± 5 psig; Closes at 80 ± 7 psig | | | | | |
| CONDENSATE DRAIN LINE (in.) | 1 at ³ / ₄ MPT | | | | | |

LEGEND

MPT — Male Pipe Thread

Field-installed accessories

| ITEM | FIELD-INSTALLED ACCESSORY |
|-------------------|---------------------------|
| Hot Water Coil | X |
| Supply Air Plenum | X |

Field-installed accessories

Supply air plenum provides adjustable horizontal and vertical louvers for controlled free blow into conditioned space. The plenum mounts easily on top of base unit and matches unit styling.

Hot water coil provides a 2-row coil encased in a 5 in. deep metal casing.

Dimensions — 50XCW06,08



REAR RETURN, VERTICAL DISCHARGE

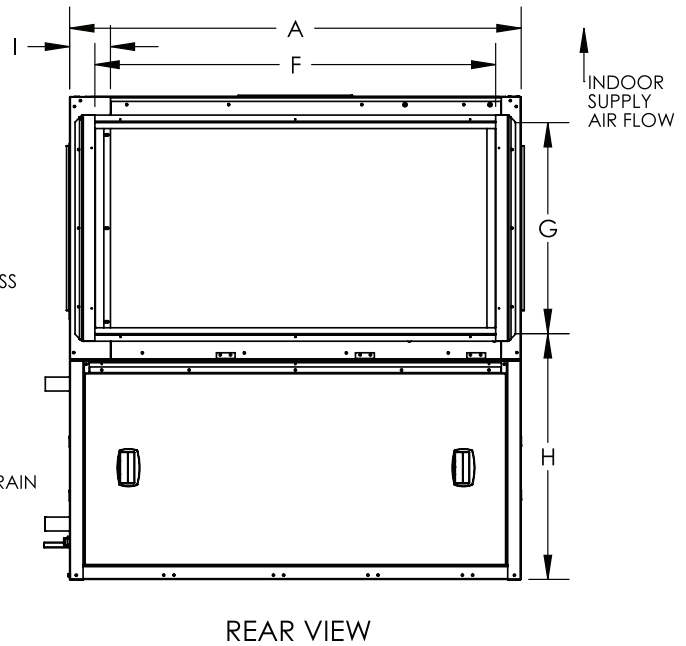
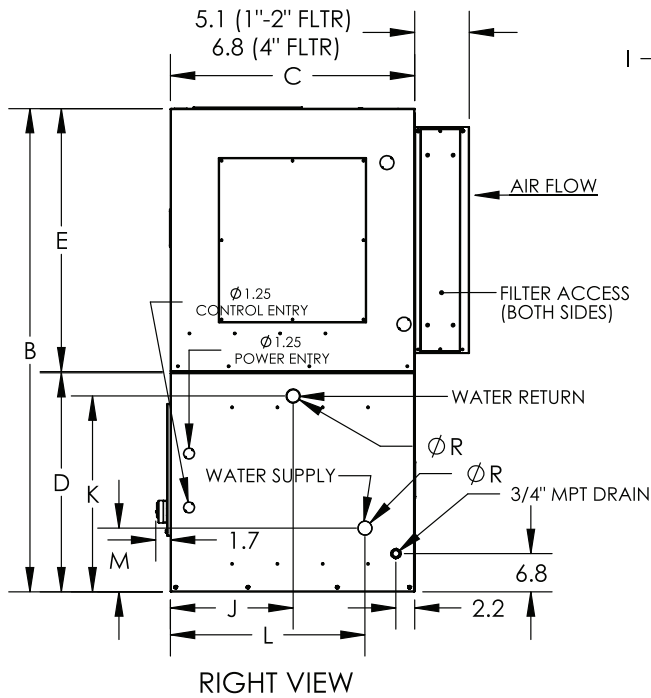
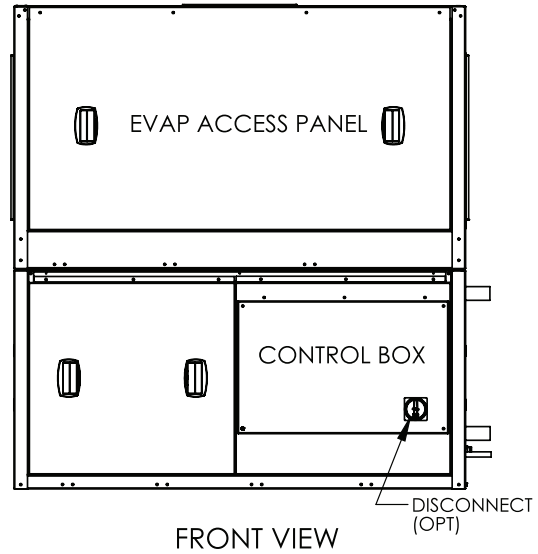
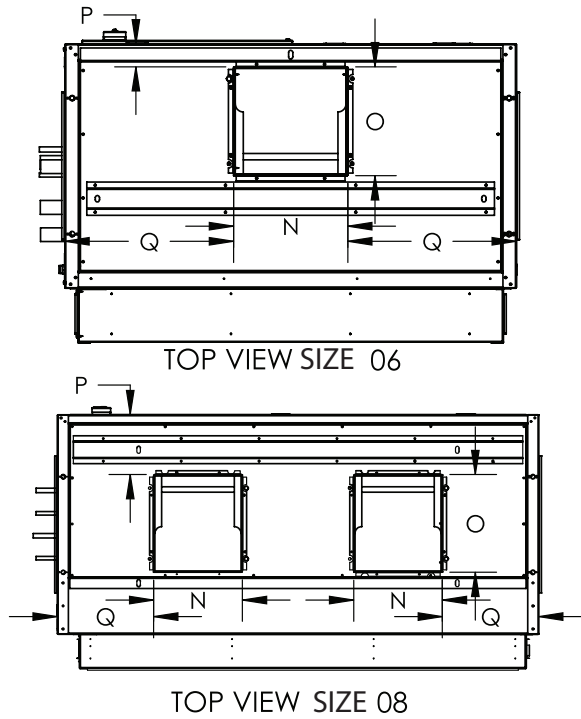

| UNIT 50XCW | WIDTH | HEIGHT | DEPTH | COND SECTION | EVAP SECTION | EVAPORATOR RETURN DUCT | | | | WATER RETURN CONN | | WATER SUPPLY CONN | | EVAP SUPPLY DUCT (Blower Opening) | | | | SUPPLY/ RETURN DIAMETER (OD) |
|---------------|-------|--------|-------|-----------------|-----------------|---------------------------|------|------|-----|-------------------------|------|-------------------------|-----|--------------------------------------|------|-----|------|---------------------------------------|
| | A | B | C | D | E | F | G | H | I | J | K | L | M | N | O | P | Q | R |
| 06 | 53.1 | 57.0 | 29.0 | 25.8 | 31.0 | 47.2 | 24.8 | 28.9 | 4.8 | 14.4 | 23.0 | 22.9 | 7.5 | 13.4 | 12.8 | 2.7 | 19.8 | 1.625 |
| 08 | 53.1 | 57.0 | 29.0 | 25.8 | 31.0 | 47.2 | 24.8 | 28.9 | 4.8 | 14.4 | 23.0 | 22.9 | 7.5 | 13.4 | 12.8 | 2.7 | 7.6 | 1.625 |

NOTE: Dimensions are in inches.

Dimensions — 50XCW12,14



REAR RETURN, VERTICAL DISCHARGE

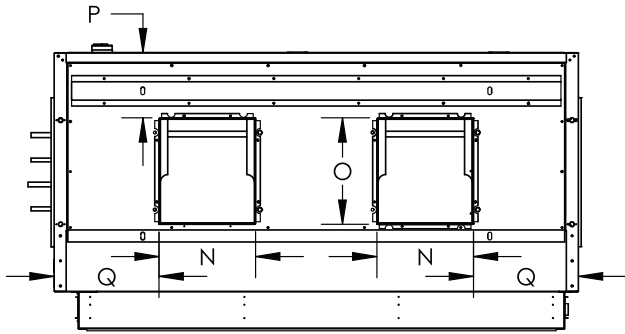

TOP VIEW

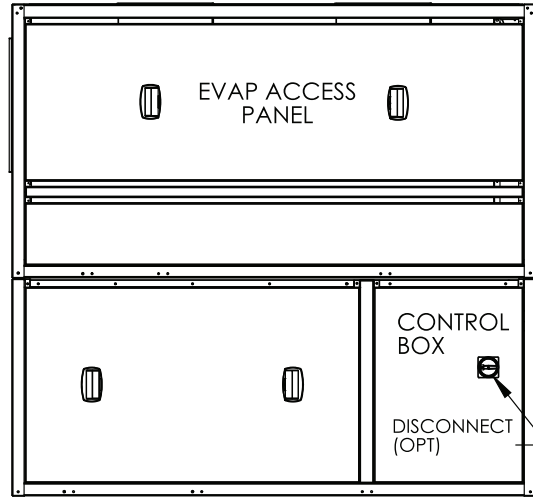

FRONT VIEW

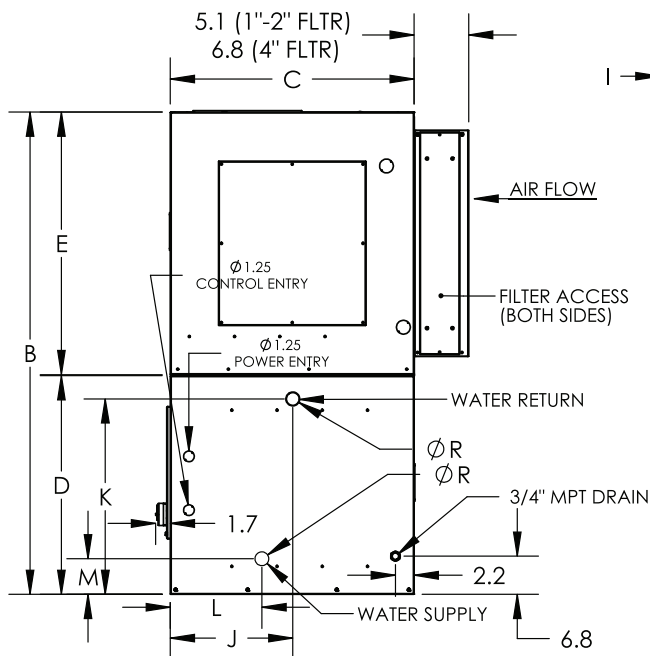

RIGHT VIEW

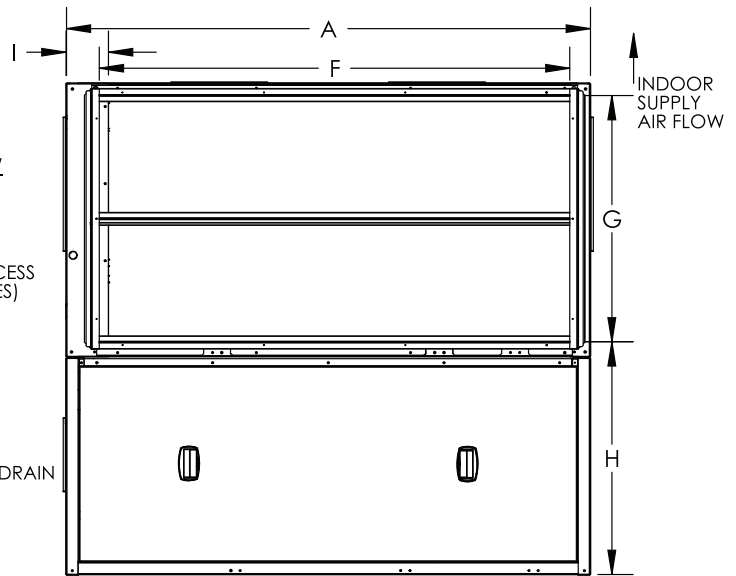

REAR VIEW

| UNIT 50XCW | WIDTH | | HEIGHT | DEPTH | COND SECTION | | EVAP SECTION | | | EVAPORATOR RETURN DUCT | | | | WATER RETURN CONN | | WATER SUPPLY CONN | | EVAP SUPPLY DUCT (Blower Opening) | | | | SUPPLY/ RETURN DIAMETER (OD) |
|---------------|-------|------|--------|-------|--------------|------|--------------|------|-----|------------------------|------|------|-----|-------------------|------|-------------------|------|-----------------------------------|--|--|--|------------------------------|
| | A | B | C | D | E | F | G | H | I | J | K | L | M | N | O | P | Q | R | | | | |
| 12 | 68.0 | 64.0 | 31.2 | 28.0 | 35.5 | 61.1 | 31.8 | 29.4 | 5.5 | 17.7 | 22.7 | 10.8 | 4.2 | 12.5 | 13.8 | 8.5 | 13.6 | 2.125 | | | | |
| 14 | 68.0 | 64.0 | 31.2 | 28.0 | 35.5 | 61.1 | 31.8 | 29.4 | 5.5 | 17.7 | 22.7 | 10.8 | 4.2 | 12.5 | 13.8 | 8.5 | 13.6 | 2.125 | | | | |

NOTE: Dimensions are in inches.

REAR RETURN, VERTICAL DISCHARGE WITH HEAD PRESSURE CONTROL (HPC)

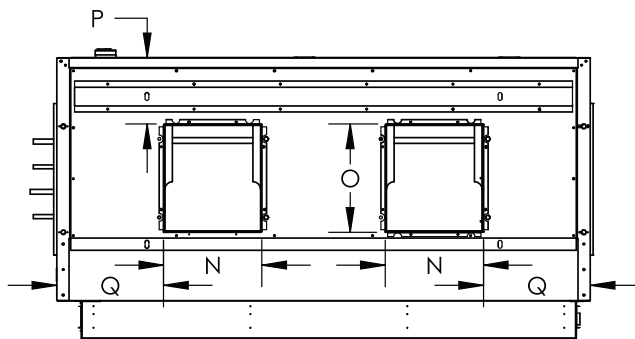

TOP VIEW

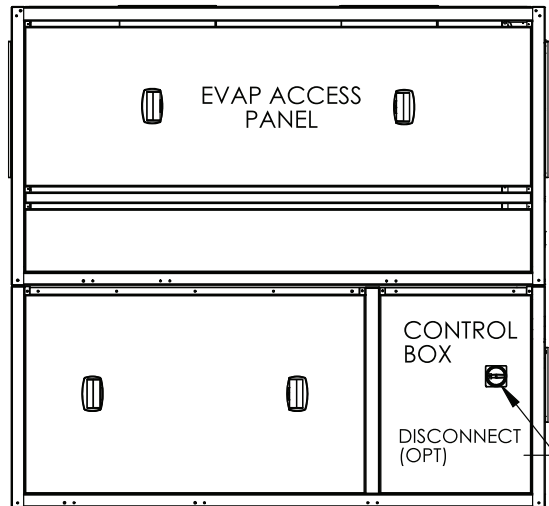

FRONT VIEW

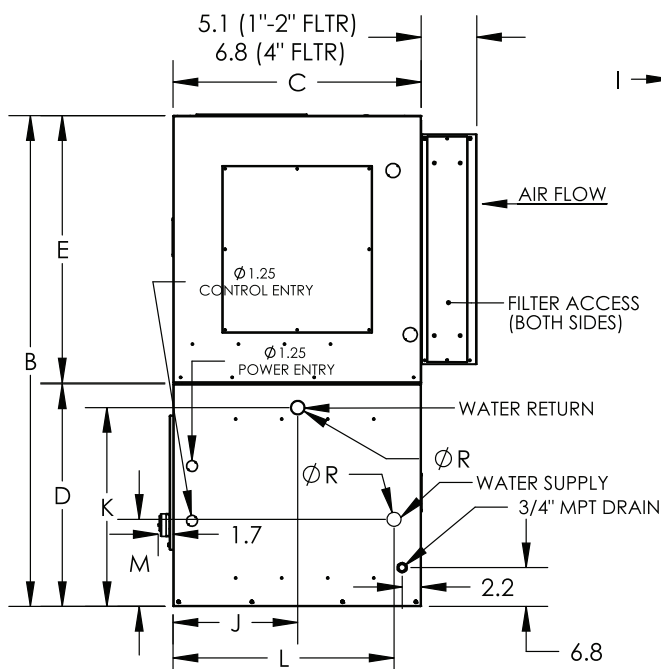

RIGHT VIEW

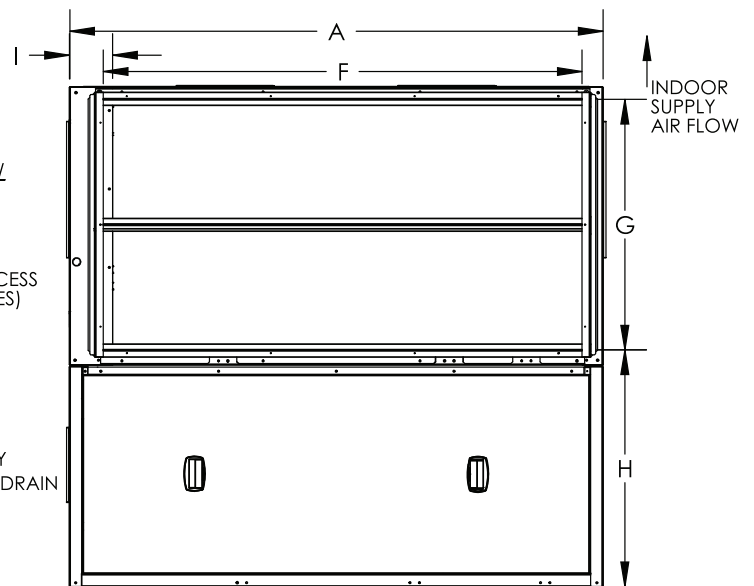

REAR VIEW

| UNIT 50XCW | WIDTH | HEIGHT | DEPTH | COND SECTION | EVAP SECTION | EVAPORATOR RETURN DUCT | | | | WATER RETURN CONN | | WATER SUPPLY CONN | | EVAP SUPPLY DUCT (Blower Opening) | | | | SUPPLY/ RETURN DIAMETER (OD) |
|---------------|-------|--------|-------|-----------------|-----------------|---------------------------|------|------|-----|-------------------------|------|-------------------------|------|--------------------------------------|------|-----|------|------------------------------------|
| | A | B | C | D | E | F | G | H | I | J | K | L | M | N | O | P | Q | R |
| 12 | 68.0 | 64.0 | 31.2 | 28.0 | 35.5 | 61.1 | 31.8 | 29.4 | 5.5 | 17.7 | 22.7 | 25.6 | 10.1 | 12.5 | 13.8 | 8.5 | 13.6 | 2.125 |
| 14 | 68.0 | 64.0 | 31.2 | 28.0 | 35.5 | 61.1 | 31.8 | 29.4 | 5.5 | 17.7 | 22.7 | 25.6 | 10.1 | 12.5 | 13.8 | 8.5 | 13.6 | 2.125 |

NOTE: Dimensions are in inches.

Dimensions — 50XCW12,14 (cont)

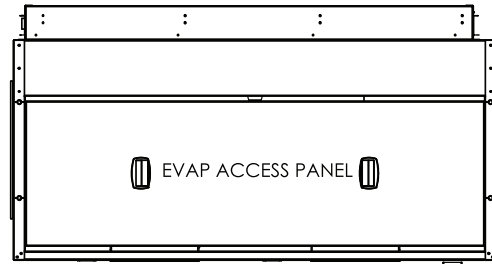
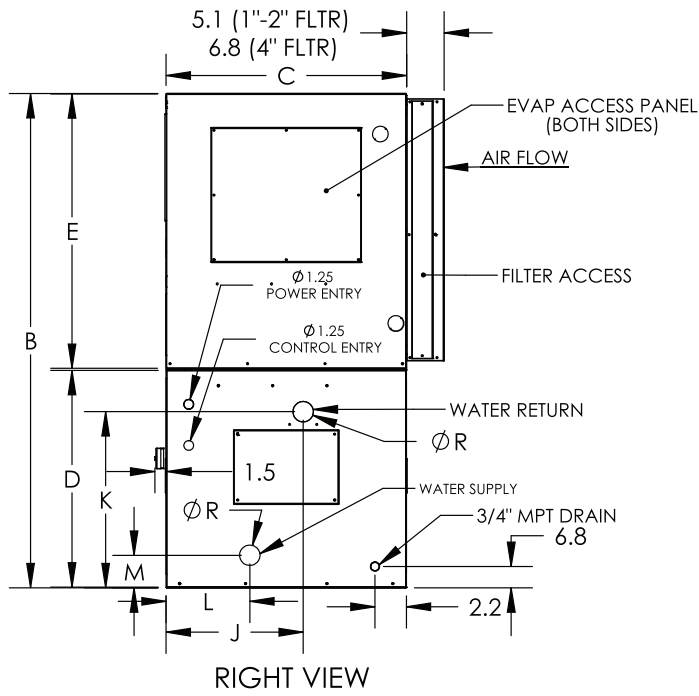

TOP VIEW

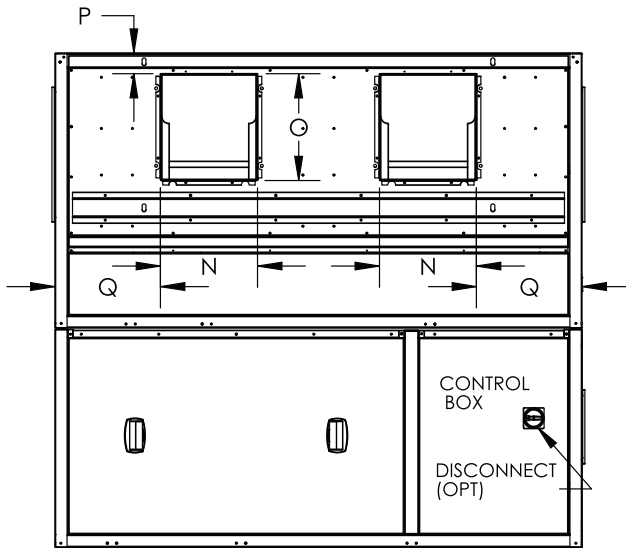

FRONT VIEW

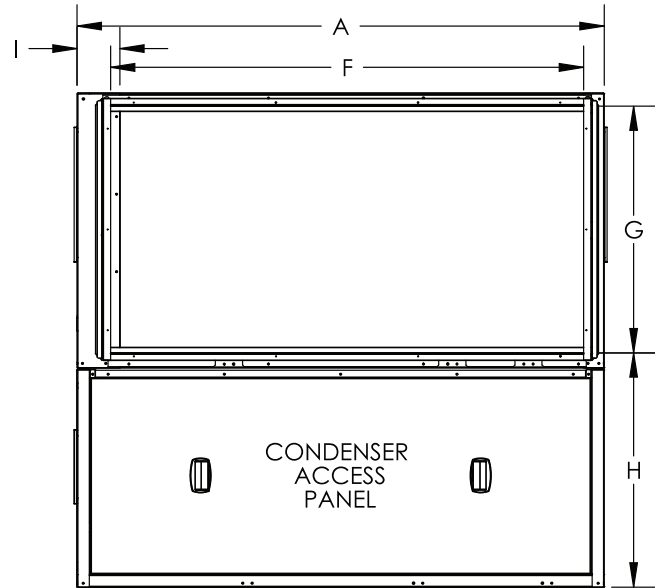

REAR VIEW

| UNIT 50XCW | WIDTH | HEIGHT | DEPTH | COND SECTION | EVAP SECTION | EVAPORATOR RETURN DUCT | | | | WATER RETURN CONN | | WATER SUPPLY CONN | | EVAP SUPPLY DUCT (Blower Opening) | | | | SUPPLY/ RETURN DIAMETER (OD) |
|---------------|-------|--------|-------|-----------------|-----------------|---------------------------|------|------|-----|-------------------------|------|-------------------------|-----|--------------------------------------|------|-----|------|------------------------------------|
| | A | B | C | D | E | F | G | H | I | J | K | L | M | N | O | P | Q | R |
| 12 | 68.0 | 64.0 | 31.2 | 28.0 | 35.5 | 61.1 | 31.8 | 29.4 | 5.5 | 17.7 | 22.7 | 10.8 | 4.2 | 12.5 | 13.8 | 2.7 | 13.6 | 2.125 |
| 14 | 68.0 | 64.0 | 31.2 | 28.0 | 35.5 | 61.1 | 31.8 | 29.4 | 5.5 | 17.7 | 22.7 | 10.8 | 4.2 | 12.5 | 13.8 | 2.7 | 13.6 | 2.125 |

NOTE: Dimensions are in inches.

REAR RETURN, FRONT DISCHARGE WITH HEAD PRESSURE CONTROL (HPC)

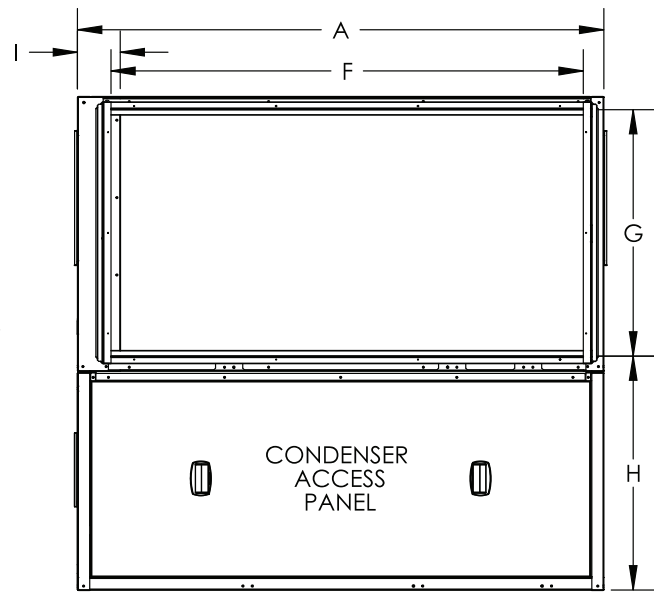
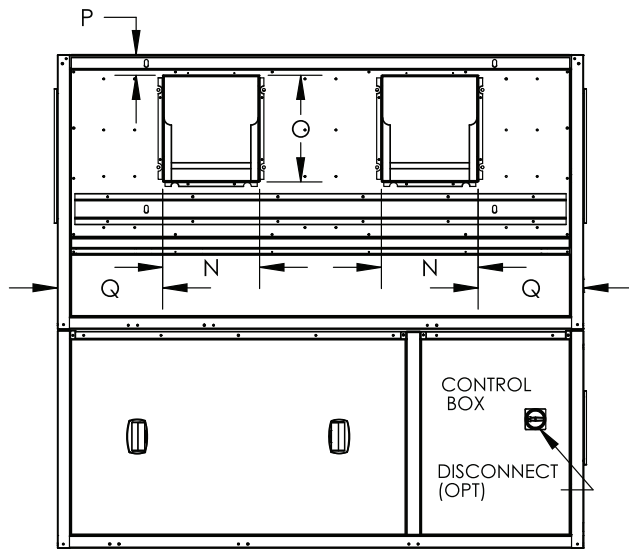
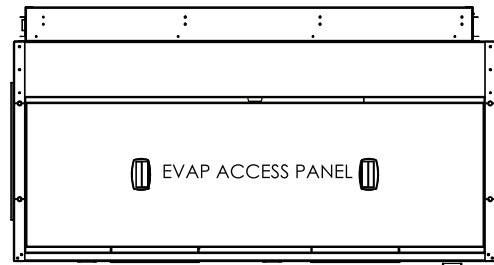
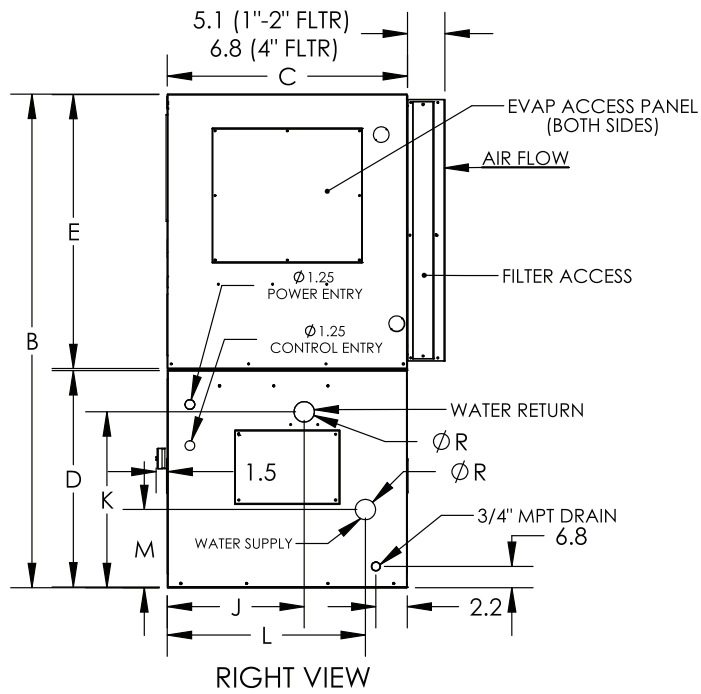

| UNIT 50XCW | WIDTH | HEIGHT | DEPTH | COND SECTION | EVAP SECTION | EVAPORATOR RETURN DUCT | | | | WATER RETURN CONN | | WATER SUPPLY CONN | | EVAP SUPPLY DUCT (Blower Opening) | | | | SUPPLY/ RETURN DIAMETER (OD) |
|---------------|-------|--------|-------|-----------------|-----------------|---------------------------|------|------|-----|-------------------------|------|-------------------------|------|--------------------------------------|------|-----|------|------------------------------------|
| | A | B | C | D | E | F | G | H | I | J | K | L | M | N | O | P | Q | R |
| 12 | 68.0 | 64.0 | 31.2 | 28.0 | 35.5 | 61.1 | 31.8 | 29.4 | 5.5 | 17.7 | 22.7 | 25.6 | 10.1 | 12.5 | 13.8 | 2.7 | 13.6 | 2.125 |
| 14 | 68.0 | 64.0 | 31.2 | 28.0 | 35.5 | 61.1 | 31.8 | 29.4 | 5.5 | 17.7 | 22.7 | 25.6 | 10.1 | 12.5 | 13.8 | 2.7 | 13.6 | 2.125 |

NOTE: Dimensions are in inches.

Dimensions — 50XCW16,24 (cont)



REAR RETURN, FRONT DISCHARGE

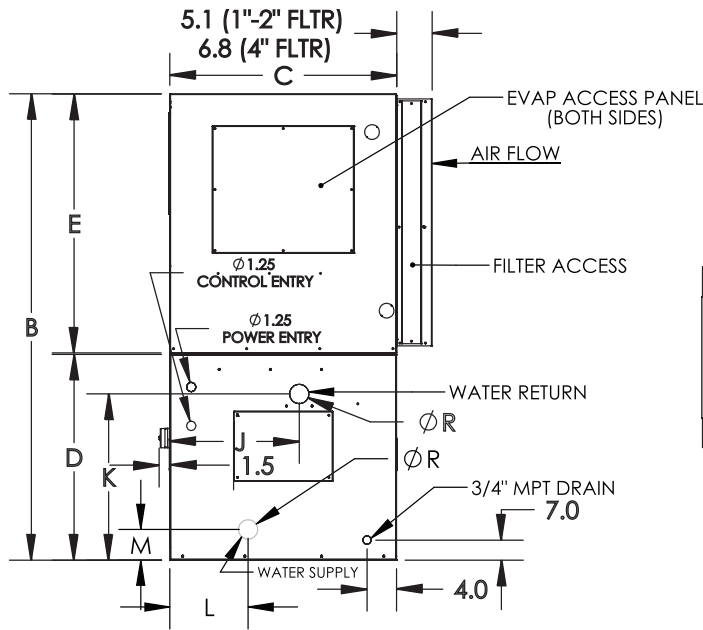

RIGHT VIEW

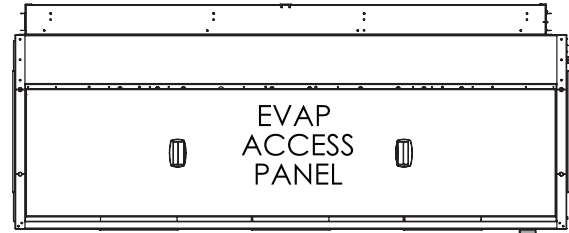

TOP VIEW

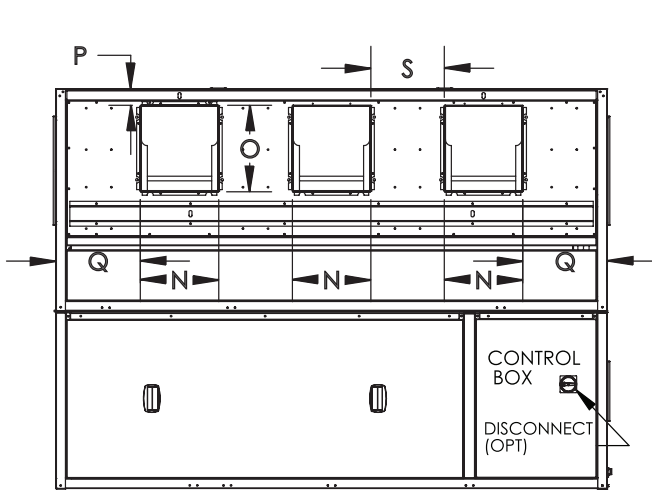

FRONT VIEW

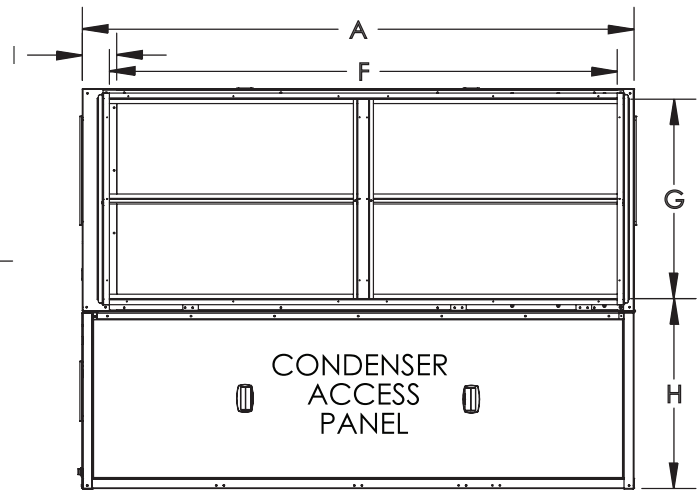

REAR VIEW

| UNIT 50XCW | WIDTH | | HEIGHT | DEPTH | COND SECTION | EVAP SECTION | EVAPORATOR RETURN DUCT | | | | WATER RETURN CONN | | WATER SUPPLY CONN | | EVAP SUPPLY DUCT (Blower Opening) | | | | SUPPLY/ RETURN DIAMETER (OD) |
|---------------|-------|------|--------|-------|-----------------|-----------------|---------------------------|------|-----|------|-------------------------|------|-------------------------|------|--------------------------------------|-----|------|------|---------------------------------------|
| | A | B | C | D | E | F | G | H | I | J | K | L | M | N | O | P | Q | S | R |
| 16 | 88.0 | 66.7 | 31.2 | 31.2 | 35.5 | 81.0 | 31.8 | 33.2 | 5.5 | 17.8 | 22.8 | 25.6 | 10.1 | 12.5 | 13.8 | 2.6 | 13.5 | 11.7 | 2.625 |
| 24 | 88.0 | 70.8 | 31.2 | 31.2 | 39.5 | 81.5 | 35.8 | 33.3 | 5.5 | 17.8 | 22.8 | 25.6 | 10.1 | 14.9 | 13.8 | 2.6 | 8.3 | 13.2 | 2.625 |

NOTE: Dimensions are in inches.

REAR RETURN, FRONT DISCHARGE WITH HEAD PRESSURE CONTROL (HPC)

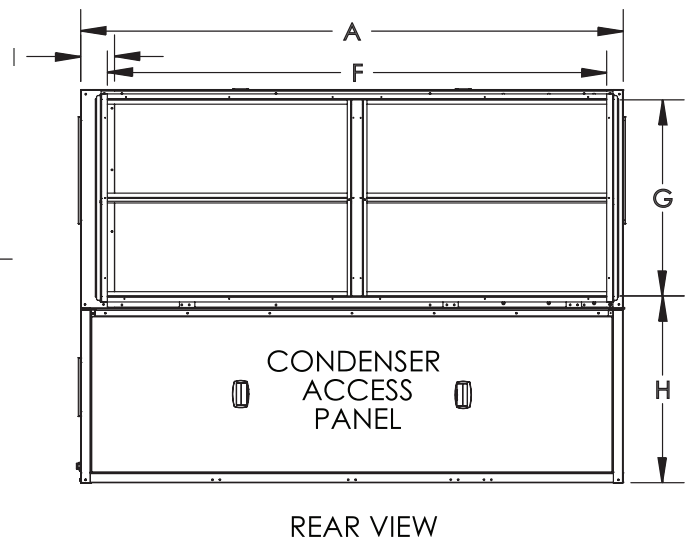
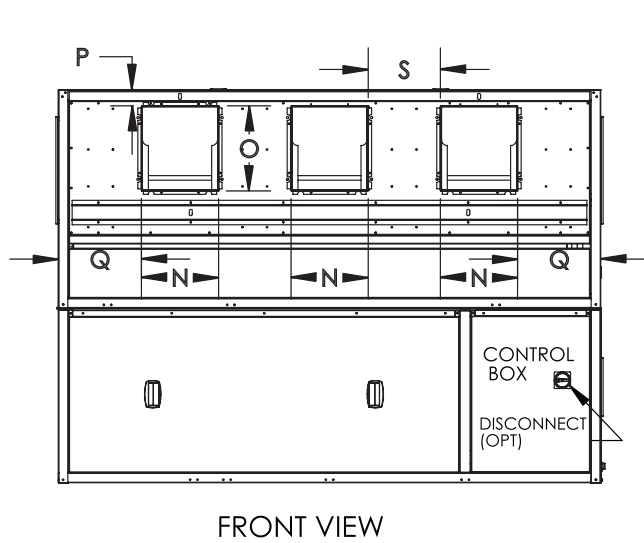
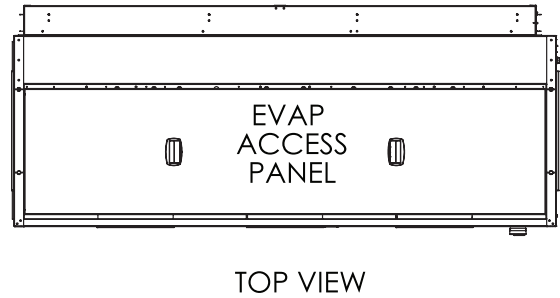
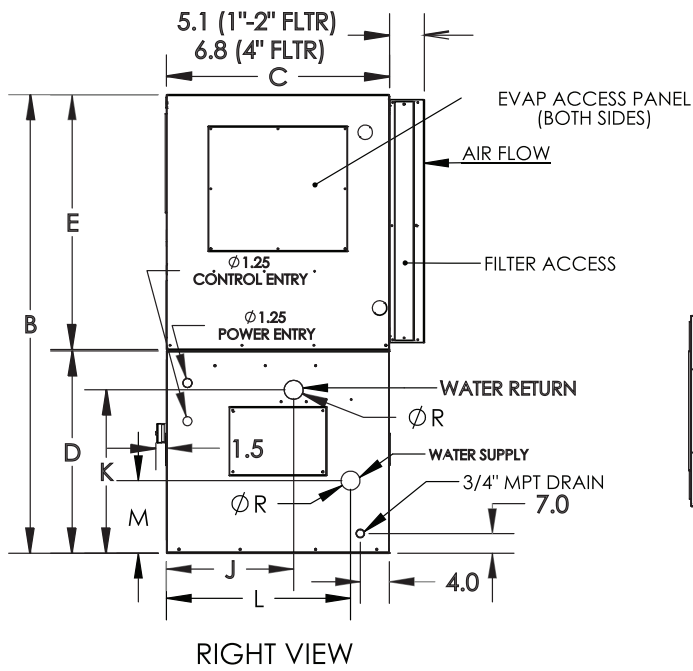

| UNIT 50XCW | WIDTH | HEIGHT | DEPTH | COND SECTION | EVAP SECTION | EVAPORATOR RETURN DUCT | | | | WATER RETURN CONN | | WATER SUPPLY CONN | | EVAP SUPPLY DUCT (Blower Opening) | | | | | SUPPLY/ RETURN DIAMETER (OD) |
|---------------|-------|--------|-------|-----------------|-----------------|---------------------------|------|------|-----|-------------------------|------|-------------------------|-----|--------------------------------------|------|-----|------|------|---------------------------------------|
| | A | B | C | D | E | F | G | H | I | J | K | L | M | N | O | P | Q | S | R |
| 16 | 88.0 | 66.7 | 31.2 | 31.2 | 35.5 | 81.0 | 31.8 | 33.2 | 5.5 | 17.8 | 22.8 | 10.7 | 4.2 | 12.5 | 13.8 | 2.6 | 13.5 | 11.7 | 2.625 |
| 24 | 88.0 | 70.8 | 31.2 | 31.2 | 39.5 | 81.5 | 35.8 | 33.3 | 5.5 | 17.8 | 22.8 | 10.7 | 4.2 | 14.9 | 13.8 | 2.6 | 8.3 | 13.2 | 2.625 |

NOTE: Dimensions are in inches.

Dimensions (cont)



50XC PLENUM UNIT

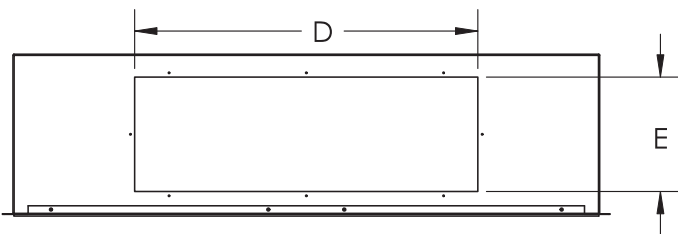
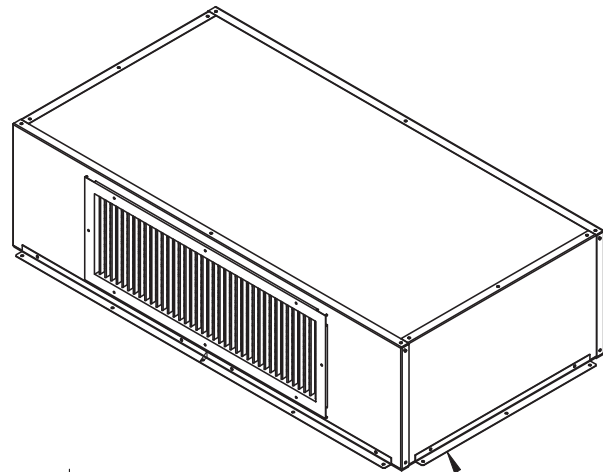

**FRONT VIEW
LESS GRILLE**

MOUNTING ANGLES

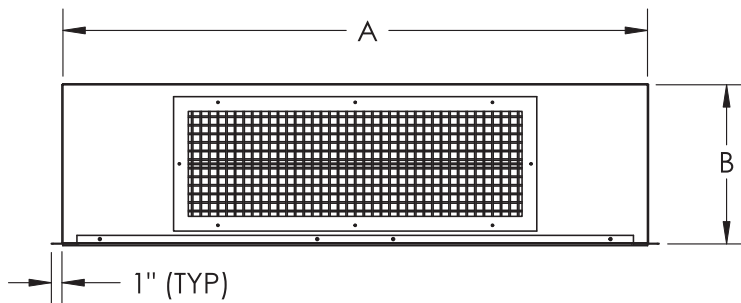

FRONT VIEW

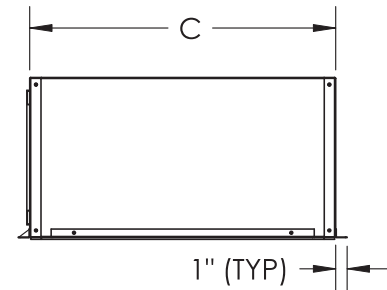

RIGHT VIEW

| MODEL | UNIT SIZE | A | B | C | D | E | WGT (lb) |
|-----------------|-----------|------|------|------|------|------|----------|
| 50XCW900-200A00 | 06 | 51.3 | 14.0 | 26.8 | 30.0 | 10.0 | 65 |
| 50XCW900-201A00 | 08 | 51.3 | 14.0 | 26.8 | 45.0 | 10.0 | 65 |
| 50XCW900-202A00 | 12 | 66.0 | 14.0 | 28.9 | 60.0 | 10.0 | 80 |
| 50XCW900-203A00 | 14 | 66.0 | 19.0 | 28.9 | 48.0 | 15.0 | 80 |
| 50XCW900-204A00 | 16 | 86.0 | 19.0 | 28.9 | 60.0 | 15.0 | 115 |
| 50XCW900-205A00 | 24 | 86.0 | 19.0 | 28.9 | 80.0 | 15.0 | 115 |

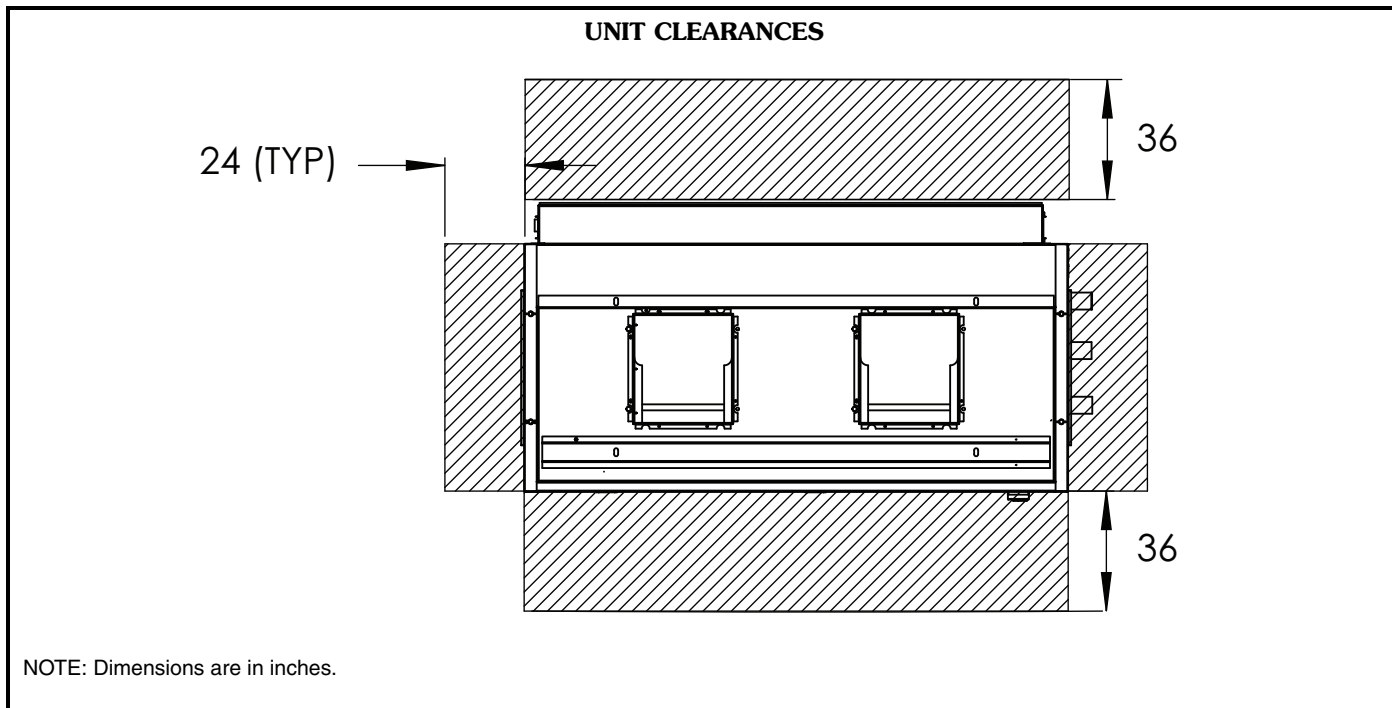

Selection procedure (with 50XCW12 unit example)

I Determine design conditions.

Given (50XCW Water-Cooled):

Cooling Requirements

| | |
|--|--------------|
| Total Cooling Capacity (TC) | 111,000 Btuh |
| Sensible Cooling Capacity | 84,000 Btuh |
| Evaporator Air Quantity | 4,000 cfm |
| Summer Entering-Air Conditions: | |
| Entering dry bulb (edb) | 80 F |
| Entering wet bulb (ewb) | 67 F |
| Entering Water Temperature (ewt) | 85 F |
| Entering Condenser Air Temperature (Air-Cooled Selection) (EAT) | 95 F |
| Flow Rate | 20 gpm |
| Unit Voltage | 460-v |

Fan Requirements

| | |
|--|------------|
| External Static Pressure Required (ESP) | 0.3 in. wg |
|--|------------|

II Select unit(s) based on cooling requirements.

Water-Cooled Selection Method — 50XCW
Enter the Gross Cooling Capacity table on page 20 for unit at 4000 cfm and required wet bulb of 67 F, and read down to the section displaying capacities

with 85 F ewt with a water flow of 20 gpm. For example (50XCW12 unit):

| | |
|--------------------------|-----------|
| Airflow | 4,000 cfm |
| Entering Air Temperature | 80 F/67 F |
| ewt | 85 F |
| gpm | 20.0 |

| | |
|------------------------------|--------------|
| TC | 137,300 Btuh |
| SHC | 101,400 Btuh |
| Compressor Motor Power Input | 7.46 kW |

This unit meets the unit cooling requirements.

III Determine fan requirements.

External static pressure (ESP) required 0.30 (in. wg)
Enter Evaporator Fan Performance curve, page 30 for selected unit size, cfm, and static pressure required to obtain the following data:

For 50XCW12 at 4,000 cfm and 0.30 ESP, the fan operates at 689 rpm and requires 1.14 brake horsepower.

Since unit 50XCW12 standard motor horsepower is 1 HP, an optional 1½ HP motor is required to produce the necessary cfm and ESP for this job.

Performance data



GROSS COOLING CAPACITIES

50XCW06 (5 TONS)

| Entering Condenser Water | | BF | AIR ENTERING EVAPORATOR — CFM AT 80 F EDB | | | | | | | | | | | |
|--------------------------|-----|-------|---|-------|-------|-------|-------|-------|-------|-------|-------|-------|-------|-------|
| TEMP (F) | GPM | | 2500 | | | | 2000 | | | | 1500 | | | |
| | | | Air Entering Evaporator — Ewb (F) | | | | | | | | | | | |
| | | | 57 | 62 | 67 | 75 | 57 | 62 | 67 | 75 | 57 | 62 | 67 | 75 |
| | | | 0.43 | 0.22 | 0.20 | 0.17 | 0.32 | 0.17 | 0.16 | 0.11 | 0.17 | 0.12 | 0.12 | 0.03 |
| 65 | 10 | TC | 70.7 | 72.0 | 77.2 | 86.7 | 66.7 | 69.6 | 74.8 | 84.1 | 60.5 | 65.5 | 70.9 | 80.5 |
| | | SHC | 70.7 | 67.8 | 56.4 | 37.4 | 66.7 | 61.2 | 51.6 | 35.6 | 60.5 | 52.7 | 45.8 | 33.3 |
| | | LDB | 54.05 | 55.26 | 59.52 | 66.45 | 49.38 | 52.07 | 56.60 | 63.91 | 42.95 | 47.95 | 52.28 | 59.96 |
| | | LWB | 45.85 | 51.82 | 57.21 | 65.82 | 43.59 | 49.45 | 54.88 | 63.63 | 40.33 | 45.70 | 51.13 | 59.96 |
| | 13 | TC | 71.2 | 72.6 | 78.1 | 87.8 | 66.8 | 69.7 | 75.1 | 84.3 | 61.1 | 65.9 | 71.4 | 81.4 |
| | | SHC | 71.2 | 68.0 | 56.7 | 37.9 | 66.8 | 60.7 | 51.7 | 35.5 | 61.1 | 53.7 | 46.2 | 33.6 |
| | | LDB | 53.87 | 55.18 | 59.40 | 66.28 | 49.36 | 52.30 | 56.55 | 63.93 | 42.60 | 47.34 | 52.10 | 59.77 |
| | | LWB | 45.77 | 51.72 | 57.08 | 65.71 | 43.58 | 49.41 | 54.83 | 63.61 | 40.14 | 45.58 | 51.03 | 59.76 |
| | 17 | TC | 71.5 | 73.0 | 78.4 | 88.0 | 67.0 | 69.9 | 75.5 | 85.5 | 61.3 | 66.2 | 71.7 | 81.8 |
| | | SHC | 71.5 | 68.0 | 56.9 | 37.9 | 67.0 | 61.4 | 51.8 | 35.7 | 61.3 | 53.8 | 46.2 | 33.7 |
| | | LDB | 53.76 | 55.10 | 59.34 | 66.26 | 49.24 | 52.01 | 56.52 | 63.86 | 42.47 | 47.28 | 52.06 | 59.69 |
| | | LWB | 45.72 | 51.65 | 57.04 | 65.67 | 43.52 | 49.38 | 54.76 | 63.42 | 40.08 | 45.50 | 50.95 | 59.68 |
| 20 | TC | 71.9 | 73.3 | 78.7 | 88.7 | 67.4 | 70.4 | 75.7 | 85.9 | 61.6 | 66.4 | 71.9 | 81.9 | |
| | SHC | 71.9 | 68.4 | 57.0 | 38.1 | 67.4 | 61.6 | 51.8 | 36.1 | 61.6 | 53.9 | 46.3 | 33.8 | |
| | LDB | 53.63 | 55.04 | 59.31 | 66.20 | 49.10 | 51.90 | 56.49 | 63.66 | 42.29 | 47.22 | 52.01 | 59.67 | |
| | LWB | 45.65 | 51.63 | 57.00 | 65.59 | 43.45 | 49.28 | 54.73 | 63.36 | 39.98 | 45.44 | 50.89 | 59.67 | |
| 75 | 10 | TC | 68.4 | 69.5 | 74.5 | 82.9 | 64.5 | 67.2 | 72.3 | 81.8 | 59.2 | 63.7 | 68.8 | 78.0 |
| | | SHC | 68.4 | 66.5 | 55.2 | 36.1 | 64.5 | 60.0 | 50.4 | 34.6 | 59.2 | 52.6 | 44.9 | 32.3 |
| | | LDB | 54.90 | 55.74 | 59.94 | 66.93 | 50.39 | 52.61 | 57.13 | 64.33 | 43.76 | 48.03 | 52.85 | 60.56 |
| | | LWB | 46.26 | 52.21 | 57.58 | 66.27 | 44.09 | 49.92 | 55.34 | 63.98 | 40.75 | 46.23 | 51.69 | 60.51 |
| | 13 | TC | 69.4 | 70.1 | 75.0 | 85.0 | 64.8 | 67.2 | 72.9 | 81.8 | 59.5 | 63.9 | 69.3 | 78.2 |
| | | SHC | 69.4 | 66.8 | 55.5 | 36.8 | 64.8 | 60.3 | 50.8 | 34.6 | 59.5 | 52.7 | 45.2 | 32.4 |
| | | LDB | 54.52 | 55.62 | 59.84 | 66.67 | 50.30 | 52.49 | 56.97 | 64.36 | 43.62 | 47.99 | 52.68 | 60.49 |
| | | LWB | 46.08 | 52.13 | 57.51 | 66.03 | 44.06 | 49.91 | 55.23 | 63.98 | 40.67 | 46.17 | 51.57 | 60.47 |
| | 17 | TC | 69.5 | 70.4 | 75.3 | 85.1 | 64.8 | 67.5 | 73.0 | 82.1 | 59.5 | 64.0 | 69.5 | 79.1 |
| | | SHC | 69.5 | 66.9 | 55.7 | 36.9 | 64.8 | 60.2 | 50.6 | 34.7 | 59.5 | 52.8 | 45.2 | 32.8 |
| | | LDB | 54.50 | 55.58 | 59.79 | 66.64 | 50.26 | 52.52 | 57.02 | 64.31 | 43.62 | 47.88 | 52.69 | 60.23 |
| | | LWB | 46.07 | 52.08 | 57.48 | 66.02 | 44.03 | 49.86 | 55.21 | 63.94 | 40.67 | 46.14 | 51.52 | 60.27 |
| 20 | TC | 69.5 | 70.4 | 76.0 | 85.2 | 65.2 | 67.8 | 73.4 | 83.2 | 59.6 | 64.2 | 69.8 | 79.4 | |
| | SHC | 69.5 | 66.8 | 56.1 | 36.9 | 65.2 | 60.4 | 50.8 | 35.1 | 59.6 | 52.8 | 45.3 | 32.8 | |
| | LDB | 54.49 | 55.60 | 59.64 | 66.64 | 50.07 | 52.45 | 56.94 | 64.13 | 43.53 | 47.89 | 52.60 | 60.23 | |
| | LWB | 46.06 | 52.08 | 57.38 | 66.00 | 43.93 | 49.80 | 55.13 | 63.77 | 40.63 | 46.07 | 51.44 | 60.21 | |
| 85 | 10 | TC | 65.9 | 66.5 | 71.4 | 80.2 | 62.4 | 64.3 | 69.8 | 78.6 | 57.2 | 61.3 | 66.5 | 75.2 |
| | | SHC | 65.9 | 65.1 | 54.0 | 35.2 | 62.4 | 58.7 | 49.3 | 33.5 | 57.2 | 51.4 | 43.9 | 31.2 |
| | | LDB | 55.81 | 56.24 | 60.40 | 67.25 | 51.35 | 53.22 | 57.63 | 64.85 | 44.99 | 48.76 | 53.47 | 61.18 |
| | | LWB | 46.68 | 52.67 | 58.01 | 66.58 | 44.56 | 50.51 | 55.79 | 64.46 | 41.38 | 46.90 | 52.28 | 61.11 |
| | 13 | TC | 66.5 | 66.9 | 72.6 | 81.8 | 62.6 | 64.6 | 70.4 | 79.4 | 57.3 | 61.4 | 66.7 | 75.5 |
| | | SHC | 66.5 | 65.0 | 54.5 | 35.7 | 62.6 | 59.1 | 49.4 | 33.7 | 57.3 | 51.6 | 43.9 | 31.4 |
| | | LDB | 55.57 | 56.27 | 60.21 | 67.07 | 51.26 | 53.03 | 57.60 | 64.75 | 44.97 | 48.66 | 53.45 | 61.08 |
| | | LWB | 46.57 | 52.61 | 57.85 | 66.40 | 44.52 | 50.43 | 55.75 | 64.35 | 41.37 | 46.89 | 52.24 | 61.04 |
| | 17 | TC | 66.9 | 67.6 | 72.7 | 81.9 | 62.9 | 64.8 | 70.1 | 79.4 | 57.8 | 61.5 | 67.0 | 75.7 |
| | | SHC | 66.9 | 65.5 | 54.5 | 35.8 | 62.9 | 58.9 | 49.6 | 33.7 | 57.8 | 51.5 | 44.2 | 31.4 |
| | | LDB | 55.44 | 56.10 | 60.21 | 67.03 | 51.12 | 53.13 | 57.49 | 64.75 | 44.66 | 48.72 | 53.30 | 61.09 |
| | | LWB | 46.51 | 52.50 | 57.83 | 66.38 | 44.45 | 50.40 | 55.73 | 64.35 | 41.21 | 46.85 | 52.17 | 61.00 |
| 20 | TC | 67.1 | 67.7 | 73.2 | 82.2 | 63.0 | 65.1 | 70.6 | 79.9 | 58.0 | 62.0 | 67.1 | 76.1 | |
| | SHC | 67.1 | 65.2 | 55.0 | 35.8 | 63.0 | 59.1 | 49.6 | 33.9 | 58.0 | 51.7 | 44.1 | 31.5 | |
| | LDB | 55.35 | 56.19 | 60.03 | 67.02 | 51.10 | 53.06 | 57.50 | 64.65 | 44.51 | 48.58 | 53.33 | 61.00 | |
| | LWB | 46.47 | 52.49 | 57.77 | 66.35 | 44.44 | 50.35 | 55.64 | 64.27 | 41.14 | 46.70 | 52.13 | 60.92 | |
| | | | 3.66 | 3.66 | 3.85 | 3.65 | 3.68 | 3.68 | 3.58 | 3.75 | 3.75 | 3.68 | 3.62 | |

LEGEND

- BF — Bypass Factor
- EDB — Entering Dry Bulb (F)
- EWB — Entering Wet Bulb (F)
- LDB — Leaving Dry Bulb (F)
- LWB — Leaving Wet Bulb (F)
- SHC — Sensible Capacity (1000 Btu/hr)
- TC — Total Capacity (1000 Btu/hr)
- kW — Compressor Motor Power Input (kilowatts)



GROSS COOLING CAPACITIES (cont)

50XCW06 (5 TONS) (cont)

| Entering Condenser Water | | BF | AIR ENTERING EVAPORATOR — CFM AT 80 F EDB | | | | | | | | | | | |
|--------------------------|-----|-------|---|-------|-------|-------|-------|-------|-------|-------|-------|-------|-------|-------|
| TEMP (F) | GPM | | 2500 | | | | 2000 | | | | 1500 | | | |
| | | | Air Entering Evaporator — Ewb (F) | | | | | | | | | | | |
| | | | 57 | 62 | 67 | 75 | 57 | 62 | 67 | 75 | 57 | 62 | 67 | 75 |
| | | | 0.43 | 0.22 | 0.20 | 0.17 | 0.32 | 0.17 | 0.16 | 0.11 | 0.17 | 0.12 | 0.12 | 0.03 |
| 95 | 10 | TC | 62.9 | 64.2 | 68.3 | 76.7 | 60.2 | 61.5 | 67.6 | 74.5 | 55.3 | 58.7 | 63.7 | 72.1 |
| | | SHC | 62.9 | 62.9 | 52.7 | 33.9 | 60.2 | 57.5 | 48.6 | 32.1 | 55.3 | 50.1 | 42.6 | 30.1 |
| | | LDB | 56.89 | 57.05 | 60.88 | 67.71 | 52.39 | 53.78 | 57.92 | 65.48 | 46.17 | 49.56 | 54.22 | 61.88 |
| | | LWB | 47.19 | 53.02 | 58.44 | 66.98 | 45.06 | 51.06 | 56.18 | 65.08 | 41.98 | 47.65 | 52.99 | 61.77 |
| | 13 | TC | 63.4 | 64.3 | 69.0 | 77.0 | 60.2 | 61.7 | 66.8 | 75.2 | 55.5 | 58.7 | 64.0 | 72.6 |
| | | SHC | 63.4 | 64.3 | 53.1 | 34.1 | 60.2 | 57.3 | 48.1 | 32.2 | 55.5 | 50.2 | 42.7 | 30.2 |
| | | LDB | 56.71 | 56.53 | 60.73 | 67.65 | 52.38 | 53.85 | 58.18 | 65.40 | 46.04 | 49.47 | 54.19 | 61.80 |
| | | LWB | 47.11 | 53.01 | 58.35 | 66.94 | 45.06 | 51.02 | 56.33 | 64.97 | 41.92 | 47.63 | 52.92 | 61.67 |
| | 17 | TC | 64.0 | 64.8 | 69.2 | 77.9 | 60.7 | 62.2 | 67.0 | 75.5 | 55.5 | 59.1 | 64.3 | 72.7 |
| | | SHC | 64.0 | 63.3 | 52.9 | 34.3 | 60.7 | 57.5 | 48.1 | 32.3 | 55.5 | 50.2 | 43.0 | 30.3 |
| | | LDB | 56.52 | 56.87 | 60.79 | 67.55 | 52.15 | 53.74 | 58.19 | 65.38 | 46.02 | 49.46 | 54.02 | 61.74 |
| | | LWB | 47.02 | 52.94 | 58.32 | 66.84 | 44.95 | 50.92 | 56.29 | 64.94 | 41.91 | 47.55 | 52.85 | 61.65 |
| 20 | TC | 64.1 | 65.0 | 70.8 | 78.1 | 60.9 | 62.3 | 67.5 | 75.9 | 55.7 | 59.3 | 64.5 | 72.7 | |
| | SHC | 64.1 | 64.7 | 53.9 | 34.4 | 60.9 | 57.5 | 48.3 | 32.5 | 55.7 | 50.4 | 42.9 | 30.3 | |
| | LDB | 56.45 | 56.36 | 60.42 | 67.53 | 52.08 | 53.76 | 58.09 | 65.30 | 45.91 | 49.38 | 54.05 | 61.76 | |
| | LWB | 46.99 | 52.91 | 58.10 | 66.82 | 44.91 | 50.90 | 56.21 | 64.87 | 41.85 | 47.48 | 52.80 | 61.64 | |
| 100 | 10 | TC | 62.4 | 62.1 | 66.5 | 73.7 | 59.2 | 60.6 | 64.8 | 73.3 | 54.0 | 57.6 | 62.2 | 70.5 |
| | | SHC | 62.4 | 62.1 | 52.1 | 32.9 | 59.2 | 56.7 | 47.1 | 31.5 | 54.0 | 49.5 | 41.9 | 29.4 |
| | | LDB | 57.09 | 57.31 | 61.07 | 68.06 | 52.81 | 54.14 | 58.61 | 65.72 | 46.93 | 49.87 | 54.66 | 62.24 |
| | | LWB | 47.28 | 53.34 | 58.69 | 67.32 | 45.27 | 51.25 | 56.67 | 65.26 | 42.37 | 47.96 | 53.39 | 62.11 |
| | 13 | TC | 63.0 | 63.1 | 66.9 | 75.8 | 59.4 | 60.7 | 65.5 | 73.8 | 54.3 | 57.7 | 62.3 | 70.6 |
| | | SHC | 63.0 | 63.1 | 52.3 | 33.6 | 59.4 | 56.8 | 47.4 | 31.7 | 54.3 | 49.8 | 42.0 | 29.5 |
| | | LDB | 56.86 | 56.95 | 61.01 | 67.82 | 52.75 | 54.09 | 58.48 | 65.63 | 46.79 | 49.72 | 54.60 | 62.23 |
| | | LWB | 47.18 | 53.19 | 58.63 | 67.08 | 45.23 | 51.22 | 56.55 | 65.19 | 42.30 | 47.92 | 53.35 | 62.08 |
| | 17 | TC | 63.5 | 63.8 | 67.1 | 76.3 | 59.6 | 60.9 | 65.8 | 73.8 | 54.3 | 57.9 | 62.7 | 71.0 |
| | | SHC | 63.5 | 62.4 | 52.4 | 33.8 | 59.6 | 57.2 | 47.8 | 31.7 | 54.3 | 49.7 | 42.1 | 29.6 |
| | | LDB | 56.70 | 57.22 | 60.97 | 67.74 | 52.65 | 53.88 | 58.33 | 65.64 | 46.77 | 49.79 | 54.54 | 62.15 |
| | | LWB | 47.10 | 53.09 | 58.60 | 67.02 | 45.19 | 51.17 | 56.50 | 65.17 | 42.29 | 47.88 | 53.25 | 62.00 |
| 20 | TC | 63.7 | 63.9 | 67.6 | 76.4 | 59.7 | 61.0 | 65.9 | 75.5 | 54.5 | 57.9 | 62.8 | 71.5 | |
| | SHC | 63.7 | 62.8 | 52.8 | 33.8 | 59.7 | 56.9 | 47.6 | 32.3 | 54.5 | 49.6 | 42.2 | 29.8 | |
| | LDB | 56.63 | 57.07 | 60.81 | 67.73 | 52.61 | 54.03 | 58.40 | 65.36 | 46.62 | 49.82 | 54.49 | 62.04 | |
| | LWB | 47.07 | 53.07 | 58.54 | 67.01 | 45.17 | 51.15 | 56.49 | 64.93 | 42.21 | 47.88 | 53.23 | 61.90 | |
| 20 | TC | 64.7 | 64.7 | 68.3 | 76.7 | 60.2 | 61.5 | 67.6 | 74.5 | 55.3 | 58.7 | 63.7 | 72.1 | |
| | SHC | 64.7 | 64.7 | 52.7 | 33.9 | 60.2 | 57.5 | 48.6 | 32.1 | 55.3 | 50.1 | 42.6 | 30.1 | |
| | LDB | 56.89 | 57.05 | 60.88 | 67.71 | 52.39 | 53.78 | 57.92 | 65.48 | 46.17 | 49.56 | 54.22 | 61.88 | |
| | LWB | 47.19 | 53.02 | 58.44 | 66.98 | 45.06 | 51.06 | 56.18 | 65.08 | 41.98 | 47.65 | 52.99 | 61.77 | |

LEGEND

- BF** — Bypass Factor
- EDB** — Entering Dry Bulb (F)
- EWB** — Entering Wet Bulb (F)
- LDB** — Leaving Dry Bulb (F)
- LWB** — Leaving Wet Bulb (F)
- SHC** — Sensible Capacity (1000 Btu/hr)
- TC** — Total Capacity (1000 Btu/hr)
- kW** — Compressor Motor Power Input (kilowatts)

Performance data (cont)



GROSS COOLING CAPACITIES (cont)

50XCW08 (7 1/2 TONS)

| Entering Condenser Water | | BF | AIR ENTERING EVAPORATOR — CFM AT 80 F EDB | | | | | | | | | | | |
|--------------------------|-----|-------|---|-------|-------|-------|-------|-------|-------|-------|-------|-------|-------|-------|
| TEMP (F) | GPM | | 3750 | | | | 3000 | | | | 2250 | | | |
| | | | Air Entering Evaporator — Ewb (F) | | | | | | | | | | | |
| | | | 57 | 62 | 67 | 75 | 57 | 62 | 67 | 75 | 57 | 62 | 67 | 75 |
| | | | 0.54 | 0.34 | 0.22 | 0.21 | 0.45 | 0.22 | 0.18 | 0.16 | 0.32 | 0.15 | 0.13 | 0.09 |
| 65 | 15 | TC | 85.3 | 85.2 | 88.9 | 100.2 | 81.2 | 81.5 | 87.0 | 98.1 | 75.2 | 77.9 | 83.4 | 94.7 |
| | | SHC | 85.3 | 85.2 | 72.8 | 45.8 | 81.2 | 80.6 | 66.2 | 43.1 | 75.2 | 68.6 | 58.2 | 40.1 |
| | | LDB | 59.30 | 59.29 | 62.38 | 68.96 | 55.20 | 55.39 | 59.99 | 67.02 | 49.38 | 52.04 | 56.55 | 63.92 |
| | | LWB | 48.30 | 54.17 | 59.68 | 68.13 | 46.41 | 52.44 | 57.89 | 66.44 | 43.60 | 49.46 | 55.03 | 63.65 |
| | 20 | KW | 3.84 | 3.83 | 3.82 | 3.95 | 3.83 | 3.81 | 3.81 | 3.93 | 3.80 | 3.74 | 3.79 | 3.91 |
| | | TC | 85.3 | 85.7 | 88.9 | 100.5 | 81.2 | 82.1 | 87.0 | 98.4 | 75.4 | 78.3 | 83.6 | 95.1 |
| | | SHC | 85.3 | 85.7 | 72.7 | 45.9 | 81.2 | 79.9 | 65.9 | 43.2 | 75.4 | 69.8 | 58.3 | 40.4 |
| | | LDB | 59.22 | 59.16 | 62.41 | 68.94 | 55.17 | 55.72 | 60.09 | 66.99 | 49.29 | 51.71 | 56.52 | 63.80 |
| | 25 | LWB | 48.27 | 54.12 | 59.69 | 68.11 | 46.40 | 52.40 | 57.89 | 66.41 | 43.56 | 49.48 | 55.01 | 63.60 |
| | | KW | 3.70 | 3.71 | 3.73 | 3.81 | 3.66 | 3.71 | 3.68 | 3.80 | 3.67 | 3.71 | 3.66 | 3.76 |
| | | TC | 85.4 | 85.9 | 89.5 | 100.9 | 81.8 | 82.2 | 87.6 | 99.3 | 75.5 | 78.6 | 83.9 | 95.5 |
| | | SHC | 85.4 | 84.7 | 73.2 | 45.9 | 81.8 | 79.7 | 66.4 | 43.5 | 75.5 | 70.1 | 58.6 | 40.3 |
| 30 | LDB | 59.13 | 59.13 | 62.29 | 68.92 | 55.00 | 55.78 | 59.93 | 66.90 | 49.25 | 51.60 | 56.38 | 63.81 | |
| | LWB | 48.24 | 53.99 | 59.63 | 68.07 | 46.32 | 52.40 | 57.83 | 66.32 | 43.54 | 49.40 | 54.95 | 63.55 | |
| | KW | 3.60 | 3.55 | 3.61 | 3.72 | 3.59 | 3.64 | 3.61 | 3.68 | 3.59 | 3.64 | 3.59 | 3.66 | |
| | TC | 86.3 | 86.4 | 89.9 | 101.2 | 81.8 | 82.9 | 87.9 | 99.4 | 75.5 | 78.8 | 84.7 | 95.8 | |
| 75 | 15 | SHC | 86.3 | 86.4 | 73.3 | 46.0 | 81.8 | 79.7 | 66.5 | 43.5 | 75.5 | 69.2 | 58.7 | 40.4 |
| | | LDB | 58.91 | 59.00 | 62.26 | 68.90 | 54.99 | 55.75 | 59.90 | 66.88 | 49.23 | 51.91 | 56.34 | 63.79 |
| | | LWB | 48.14 | 54.05 | 59.60 | 68.05 | 46.32 | 52.30 | 57.79 | 66.31 | 43.53 | 49.35 | 54.83 | 63.51 |
| | | KW | 3.57 | 3.57 | 3.57 | 3.66 | 3.53 | 3.55 | 3.57 | 3.62 | 3.52 | 3.52 | 3.56 | 3.62 |
| 20 | TC | 82.7 | 82.8 | 87.8 | 98.2 | 78.9 | 78.6 | 84.4 | 95.8 | 73.2 | 74.9 | 81.8 | 92.2 | |
| | SHC | 82.7 | 82.8 | 72.9 | 45.1 | 78.9 | 78.6 | 65.1 | 42.2 | 73.2 | 68.1 | 57.7 | 39.1 | |
| | LDB | 59.78 | 59.87 | 62.36 | 69.12 | 55.90 | 56.10 | 60.33 | 67.27 | 50.17 | 52.39 | 56.74 | 64.30 | |
| | LWB | 48.53 | 54.41 | 59.79 | 68.27 | 46.75 | 52.85 | 58.19 | 66.66 | 43.99 | 50.08 | 55.30 | 64.00 | |
| 25 | KW | 4.50 | 4.50 | 4.53 | 4.62 | 4.48 | 4.44 | 4.51 | 4.61 | 4.47 | 4.39 | 4.52 | 4.59 | |
| | TC | 83.4 | 83.0 | 86.9 | 97.2 | 79.0 | 78.8 | 85.1 | 95.9 | 73.4 | 75.7 | 81.2 | 91.5 | |
| | SHC | 83.4 | 83.0 | 72.3 | 44.7 | 79.0 | 78.5 | 65.3 | 42.3 | 73.4 | 68.5 | 57.4 | 38.8 | |
| | LDB | 59.62 | 59.81 | 62.52 | 69.21 | 55.87 | 56.13 | 60.28 | 67.25 | 50.08 | 52.25 | 56.88 | 64.41 | |
| 30 | LWB | 48.46 | 54.39 | 59.87 | 68.35 | 46.73 | 52.83 | 58.12 | 66.65 | 43.95 | 49.94 | 55.38 | 64.08 | |
| | KW | 4.14 | 4.34 | 4.35 | 4.40 | 4.31 | 4.30 | 4.27 | 4.44 | 4.30 | 4.22 | 4.25 | 4.31 | |
| | TC | 83.4 | 83.4 | 86.9 | 97.6 | 79.6 | 79.3 | 85.1 | 96.2 | 73.7 | 75.7 | 82.9 | 92.4 | |
| | SHC | 83.4 | 83.4 | 72.4 | 44.8 | 79.6 | 78.1 | 65.4 | 42.5 | 73.7 | 68.8 | 58.1 | 39.1 | |
| 75 | 20 | LDB | 59.61 | 59.72 | 62.49 | 69.20 | 55.68 | 56.25 | 60.24 | 67.20 | 49.97 | 52.20 | 56.59 | 64.29 |
| | | LWB | 48.46 | 54.35 | 59.87 | 68.32 | 46.64 | 52.77 | 58.12 | 66.62 | 43.89 | 50.00 | 55.11 | 63.96 |
| | | KW | 4.35 | 4.25 | 4.25 | 4.33 | 4.26 | 4.21 | 4.26 | 4.33 | 4.26 | 4.18 | 4.26 | 4.28 |
| | | TC | 83.6 | 84.2 | 87.5 | 97.8 | 79.9 | 79.5 | 85.2 | 97.1 | 74.2 | 76.2 | 82.3 | 92.5 |
| 25 | SHC | 83.6 | 84.2 | 72.5 | 44.9 | 79.9 | 78.8 | 65.7 | 42.8 | 74.2 | 68.7 | 58.0 | 39.2 | |
| | LDB | 59.56 | 59.52 | 62.50 | 69.17 | 55.59 | 56.04 | 60.15 | 67.11 | 49.76 | 52.10 | 56.68 | 64.26 | |
| | LWB | 48.43 | 54.27 | 59.82 | 68.30 | 46.60 | 52.74 | 58.10 | 66.53 | 43.79 | 49.86 | 55.23 | 63.95 | |
| | KW | 4.06 | 4.12 | 4.18 | 4.19 | 4.18 | 4.13 | 4.16 | 4.20 | 4.18 | 4.15 | 4.15 | 4.18 | |
| 85 | 15 | TC | 79.3 | 79.7 | 82.5 | 93.4 | 75.7 | 76.2 | 81.2 | 91.5 | 70.4 | 72.1 | 78.1 | 88.4 |
| | | SHC | 79.3 | 79.7 | 70.8 | 43.5 | 75.7 | 76.2 | 63.8 | 40.8 | 70.4 | 66.6 | 56.0 | 37.8 |
| | | LDB | 60.61 | 60.62 | 62.87 | 69.50 | 56.87 | 56.84 | 60.73 | 67.71 | 51.30 | 53.03 | 57.44 | 64.83 |
| | | LWB | 48.91 | 54.71 | 60.25 | 68.63 | 47.19 | 53.16 | 58.55 | 67.06 | 44.55 | 50.58 | 55.89 | 64.50 |
| | 20 | KW | 4.99 | 5.10 | 5.15 | 5.31 | 5.21 | 5.09 | 5.18 | 5.25 | 5.11 | 5.06 | 5.13 | 5.26 |
| | | TC | 80.2 | 80.8 | 82.8 | 93.7 | 76.3 | 76.2 | 81.6 | 91.8 | 70.5 | 72.4 | 78.2 | 88.8 |
| | | SHC | 80.2 | 80.8 | 70.6 | 43.5 | 76.3 | 76.2 | 64.2 | 40.9 | 70.5 | 67.0 | 56.0 | 38.0 |
| | | LDB | 60.40 | 60.36 | 62.93 | 69.51 | 56.69 | 56.84 | 60.59 | 67.68 | 51.28 | 52.86 | 57.43 | 64.73 |
| | 25 | LWB | 48.81 | 54.61 | 60.22 | 68.61 | 47.11 | 53.16 | 58.51 | 67.03 | 44.54 | 50.52 | 55.88 | 64.44 |
| | | KW | 5.16 | 5.04 | 5.00 | 5.01 | 4.91 | 4.96 | 4.97 | 5.05 | 4.88 | 4.92 | 4.98 | 5.07 |
| | | TC | 80.5 | 80.8 | 83.3 | 94.3 | 76.3 | 76.4 | 82.3 | 92.0 | 70.5 | 72.7 | 78.5 | 89.4 |
| | | SHC | 80.5 | 80.8 | 70.7 | 43.7 | 76.3 | 76.4 | 64.2 | 41.0 | 70.5 | 67.2 | 56.2 | 38.1 |
| 30 | LDB | 60.32 | 60.35 | 62.90 | 69.45 | 56.69 | 56.78 | 60.59 | 67.65 | 51.26 | 52.79 | 57.37 | 64.70 | |
| | LWB | 48.78 | 54.60 | 60.19 | 68.56 | 47.11 | 53.14 | 58.43 | 67.02 | 44.53 | 50.47 | 55.82 | 64.36 | |
| | KW | 5.02 | 4.78 | 4.89 | 4.79 | 4.87 | 4.86 | 4.96 | 4.95 | 4.88 | 4.83 | 4.87 | 4.83 | |
| | TC | 80.6 | 81.3 | 83.5 | 94.7 | 76.5 | 76.7 | 83.0 | 92.2 | 71.1 | 73.0 | 78.9 | 90.0 | |
| 75 | 15 | SHC | 80.6 | 81.3 | 70.9 | 43.8 | 76.5 | 76.7 | 64.8 | 41.0 | 71.1 | 67.3 | 56.3 | 38.3 |
| | | LDB | 60.31 | 60.23 | 62.85 | 69.42 | 56.62 | 56.70 | 60.42 | 67.65 | 51.04 | 52.73 | 57.31 | 64.60 |
| | | LWB | 48.77 | 54.55 | 60.17 | 68.53 | 47.08 | 53.10 | 58.35 | 67.00 | 44.42 | 50.42 | 55.76 | 64.29 |
| | | KW | 4.82 | 4.85 | 4.75 | 4.83 | 4.80 | 4.82 | 4.76 | 4.88 | 4.76 | 4.78 | 4.84 | 4.77 |



GROSS COOLING CAPACITIES (cont)

50XCW08 (7 1/2 TONS) (cont)

| Entering Condenser Water | | BF | AIR ENTERING EVAPORATOR — CFM AT 80 F EDB | | | | | | | | | | | | |
|--------------------------|-----|-------|---|-------|-------|-------|-------|-------|-------|-------|-------|-------|-------|-------|------|
| TEMP (F) | GPM | | 3750 | | | | 3000 | | | | 2250 | | | | |
| | | | Air Entering Evaporator — Ewb (F) | | | | | | | | | | | | |
| | | | 57 | 62 | 67 | 75 | 57 | 62 | 67 | 75 | 57 | 62 | 67 | 75 | |
| | | | 0.54 | 0.34 | 0.22 | 0.21 | 0.45 | 0.22 | 0.18 | 0.16 | 0.32 | 0.15 | 0.13 | 0.09 | |
| 95 | 15 | TC | 76.8 | 77.1 | 79.6 | 89.6 | 79.6 | 73.6 | 78.0 | 87.9 | 67.7 | 69.1 | 74.8 | 84.9 | |
| | | SHC | 76.8 | 77.1 | 69.3 | 42.2 | 69.3 | 73.6 | 62.4 | 39.5 | 67.7 | 65.3 | 54.6 | 36.5 | |
| | | LDB | 61.23 | 61.24 | 63.24 | 69.81 | 63.24 | 57.63 | 61.13 | 68.08 | 52.40 | 53.53 | 57.98 | 65.34 | |
| | | LWB | 49.19 | 54.96 | 60.51 | 68.91 | 60.51 | 53.49 | 58.92 | 67.41 | 45.08 | 51.10 | 56.41 | 64.96 | |
| | | | KW | 5.92 | 5.92 | 5.92 | 6.02 | 5.86 | 5.87 | 5.94 | 6.00 | 5.82 | 5.90 | 5.89 | 5.95 |
| | 20 | TC | 77.3 | 77.3 | 79.9 | 89.4 | 79.6 | 73.6 | 78.1 | 88.0 | 68.2 | 69.6 | 75.0 | 85.1 | |
| | | SHC | 77.3 | 77.3 | 69.8 | 42.1 | 69.4 | 73.6 | 62.7 | 39.5 | 68.2 | 65.5 | 54.9 | 36.6 | |
| | | LDB | 61.09 | 61.20 | 63.13 | 69.85 | 63.23 | 57.62 | 61.03 | 68.08 | 52.22 | 53.46 | 57.88 | 65.30 | |
| | | LWB | 49.13 | 54.95 | 60.49 | 68.92 | 60.51 | 53.48 | 58.91 | 67.40 | 44.99 | 51.02 | 56.37 | 64.94 | |
| | | | KW | 5.69 | 5.70 | 5.91 | 5.92 | 5.70 | 5.68 | 5.71 | 5.80 | 5.65 | 5.65 | 5.64 | 5.73 |
| | 25 | TC | 77.4 | 77.5 | 79.6 | 89.0 | 79.9 | 73.9 | 78.3 | 88.2 | 68.3 | 69.6 | 75.1 | 85.3 | |
| | | SHC | 77.4 | 77.5 | 69.4 | 42.0 | 69.8 | 73.9 | 62.6 | 39.7 | 68.3 | 66.0 | 54.8 | 36.6 | |
| LDB | | 61.08 | 61.15 | 63.23 | 69.86 | 63.13 | 57.54 | 61.07 | 68.04 | 52.17 | 53.27 | 57.91 | 65.29 | | |
| LWB | | 49.12 | 54.93 | 60.51 | 68.95 | 60.49 | 53.45 | 58.89 | 67.38 | 44.97 | 51.01 | 56.36 | 64.91 | | |
| | | KW | 5.62 | 5.58 | 5.59 | 5.66 | 5.62 | 5.55 | 5.58 | 5.65 | 5.55 | 5.54 | 5.56 | 5.63 | |
| 30 | TC | 77.6 | 77.6 | 80.2 | 90.6 | 80.2 | 74.0 | 78.8 | 88.4 | 68.6 | 69.9 | 75.7 | 85.7 | | |
| | SHC | 77.6 | 77.6 | 69.4 | 42.6 | 69.4 | 72.8 | 63.0 | 39.7 | 68.6 | 65.7 | 55.1 | 36.8 | | |
| | LDB | 61.04 | 61.13 | 63.22 | 69.73 | 63.22 | 57.90 | 60.94 | 68.03 | 52.07 | 53.36 | 57.81 | 65.23 | | |
| | LWB | 49.10 | 54.92 | 60.46 | 68.83 | 60.46 | 53.44 | 58.83 | 67.36 | 44.92 | 50.96 | 56.27 | 64.86 | | |
| | | KW | 5.50 | 5.52 | 5.57 | 5.69 | 5.50 | 5.50 | 5.54 | 5.59 | 5.52 | 5.47 | 5.55 | 5.61 | |
| 100 | 15 | TC | 75.3 | 75.4 | 77.6 | 86.7 | 71.9 | 72.2 | 76.2 | 85.5 | 66.4 | 68.0 | 73.6 | 83.0 | |
| | | SHC | 75.3 | 75.4 | 68.4 | 41.2 | 71.9 | 72.2 | 62.1 | 38.8 | 66.4 | 64.8 | 54.3 | 35.8 | |
| | | LDB | 61.59 | 61.66 | 63.46 | 70.06 | 58.03 | 58.06 | 61.23 | 68.31 | 52.96 | 53.76 | 58.13 | 65.60 | |
| | | LWB | 49.35 | 55.13 | 60.69 | 69.11 | 47.73 | 53.67 | 59.12 | 67.63 | 45.35 | 51.29 | 56.61 | 65.21 | |
| | | | KW | 6.28 | 6.26 | 6.28 | 6.45 | 6.26 | 6.26 | 6.32 | 6.39 | 6.23 | 6.24 | 6.30 | 6.33 |
| | 20 | TC | 75.5 | 75.8 | 77.7 | 87.6 | 72.2 | 72.2 | 76.2 | 85.7 | 67.0 | 68.4 | 73.6 | 83.4 | |
| | | SHC | 75.5 | 75.8 | 68.8 | 41.6 | 72.2 | 69.4 | 61.7 | 38.7 | 67.0 | 65.0 | 54.1 | 36.0 | |
| | | LDB | 61.54 | 61.57 | 63.36 | 69.97 | 57.94 | 58.90 | 61.36 | 68.34 | 52.71 | 53.67 | 58.20 | 65.54 | |
| | | LWB | 49.33 | 55.10 | 60.67 | 69.05 | 47.69 | 53.67 | 59.12 | 67.62 | 45.23 | 51.23 | 56.60 | 65.16 | |
| | | | KW | 6.06 | 6.10 | 6.07 | 6.09 | 6.01 | 6.04 | 6.04 | 6.23 | 6.01 | 5.99 | 6.06 | 6.10 |
| | 25 | TC | 75.8 | 75.9 | 79.2 | 87.6 | 72.4 | 72.3 | 76.7 | 86.1 | 67.2 | 68.4 | 73.7 | 83.5 | |
| | | SHC | 75.8 | 75.9 | 69.1 | 41.5 | 72.4 | 72.3 | 61.9 | 39.0 | 67.2 | 65.1 | 54.2 | 36.0 | |
| LDB | | 61.47 | 61.54 | 63.28 | 69.99 | 57.87 | 58.03 | 61.28 | 68.24 | 52.64 | 53.61 | 58.16 | 65.54 | | |
| LWB | | 49.30 | 55.09 | 60.55 | 69.05 | 47.66 | 53.65 | 59.07 | 67.57 | 45.20 | 51.23 | 56.58 | 65.15 | | |
| | | KW | 5.96 | 5.96 | 6.06 | 6.09 | 5.96 | 5.95 | 5.96 | 5.97 | 5.94 | 5.96 | 5.97 | 6.00 | |
| 30 | TC | 76.0 | 75.9 | 78.5 | 88.5 | 72.5 | 72.4 | 76.7 | 86.1 | 67.3 | 68.5 | 73.9 | 84.1 | | |
| | SHC | 76.0 | 75.9 | 68.4 | 41.8 | 72.5 | 72.4 | 62.0 | 38.9 | 67.3 | 65.0 | 54.3 | 36.2 | | |
| | LDB | 61.42 | 61.54 | 63.46 | 69.92 | 57.84 | 57.98 | 61.27 | 68.26 | 52.59 | 53.67 | 58.14 | 65.45 | | |
| | LWB | 49.27 | 55.08 | 60.60 | 68.99 | 47.65 | 53.63 | 59.06 | 67.57 | 45.17 | 51.21 | 56.55 | 65.07 | | |
| | | KW | 5.90 | 5.86 | 6.06 | 5.92 | 5.88 | 5.88 | 5.92 | 5.95 | 5.85 | 5.88 | 5.87 | 5.93 | |

LEGEND

- BF** — Bypass Factor
- EDB** — Entering Dry Bulb (F)
- EWB** — Entering Wet Bulb (F)
- LDB** — Leaving Dry Bulb (F)
- LWB** — Leaving Wet Bulb (F)
- SHC** — Sensible Capacity (1000 Btu/hr)
- TC** — Total Capacity (1000 Btu/hr)
- kW** — Compressor Motor Power Input (kilowatts)

Performance data (cont)



GROSS COOLING CAPACITIES (cont)

50XCW12 (10 TONS)

| Entering Condenser Water | | BF | AIR ENTERING EVAPORATOR — CFM AT 80 F EDB | | | | | | | | | | | |
|--------------------------|-----|-------|---|-------|-------|-------|-------|-------|-------|-------|-------|-------|-------|-------|
| TEMP (F) | GPM | | 5000 | | | | 4000 | | | | 3000 | | | |
| | | | Air Entering Evaporator — Ewb (F) | | | | | | | | | | | |
| | | | 57 | 62 | 67 | 75 | 57 | 62 | 67 | 75 | 57 | 62 | 67 | 75 |
| | | | 0.42 | 0.17 | 0.11 | 0.10 | 0.32 | 0.10 | 0.09 | 0.06 | 0.17 | 0.06 | 0.06 | 0.01 |
| 65 | 20 | TC | 141.4 | 141.9 | 150.7 | 170.2 | 133.8 | 136.9 | 146.5 | 165.7 | 122.3 | 129.5 | 139.2 | 158.2 |
| | | SHC | 141.4 | 141.9 | 116.6 | 75.1 | 133.8 | 126.3 | 105.2 | 70.6 | 122.3 | 108.5 | 92.6 | 65.7 |
| | | LDB | 54.08 | 54.11 | 58.85 | 66.41 | 49.35 | 51.22 | 56.17 | 64.06 | 42.63 | 47.02 | 52.04 | 60.27 |
| | | LWB | 45.89 | 52.01 | 57.50 | 66.06 | 43.59 | 49.70 | 55.20 | 63.86 | 40.17 | 45.94 | 51.52 | 60.31 |
| | | | KW | 5.37 | 5.40 | 5.47 | 5.64 | 5.36 | 5.38 | 5.43 | 5.60 | 5.33 | 5.30 | 5.35 |
| | 27 | TC | 142.5 | 143.6 | 152.7 | 172.0 | 134.7 | 138.2 | 148.5 | 167.5 | 122.8 | 130.3 | 140.5 | 159.3 |
| | | SHC | 142.5 | 141.3 | 117.5 | 75.7 | 134.7 | 126.9 | 106.0 | 71.2 | 122.8 | 109.5 | 93.0 | 65.8 |
| | | LDB | 53.87 | 54.23 | 58.69 | 66.31 | 49.13 | 51.08 | 55.98 | 63.92 | 42.49 | 46.76 | 51.93 | 60.23 |
| | | LWB | 45.79 | 51.89 | 57.36 | 65.95 | 43.48 | 49.58 | 55.02 | 63.73 | 40.10 | 45.85 | 51.35 | 60.19 |
| | | | KW | 5.12 | 5.19 | 5.21 | 5.30 | 5.13 | 5.17 | 5.21 | 5.27 | 5.07 | 5.09 | 5.13 |
| | 33 | TC | 143.1 | 143.8 | 153.9 | 173.2 | 134.8 | 138.8 | 149.4 | 168.6 | 123.2 | 130.7 | 141.2 | 160.2 |
| | | SHC | 143.1 | 141.6 | 118.0 | 76.1 | 134.8 | 126.8 | 106.4 | 71.6 | 123.2 | 109.7 | 93.3 | 66.2 |
| LDB | | 53.76 | 53.94 | 58.60 | 66.23 | 49.10 | 51.09 | 55.89 | 63.84 | 42.36 | 46.69 | 51.84 | 60.12 | |
| LWB | | 45.73 | 51.77 | 57.28 | 65.88 | 43.47 | 49.51 | 54.94 | 63.64 | 40.03 | 45.79 | 51.26 | 60.09 | |
| | | KW | 4.92 | 5.00 | 5.01 | 5.12 | 4.97 | 4.90 | 5.00 | 5.09 | 4.96 | 4.92 | 4.98 | |
| 40 | TC | 143.5 | 144.4 | 154.3 | 174.0 | 135.1 | 139.1 | 149.8 | 169.4 | 123.5 | 131.4 | 141.9 | 161.1 | |
| | SHC | 143.5 | 141.9 | 118.2 | 76.4 | 135.1 | 127.3 | 106.6 | 71.9 | 123.5 | 110.0 | 93.6 | 66.5 | |
| | LDB | 53.68 | 54.13 | 58.57 | 66.18 | 49.04 | 50.99 | 55.85 | 63.77 | 42.27 | 46.59 | 51.74 | 60.02 | |
| | LWB | 45.70 | 51.83 | 57.25 | 65.83 | 43.44 | 49.48 | 54.90 | 63.58 | 39.98 | 45.69 | 51.16 | 59.99 | |
| | | KW | 4.84 | 4.92 | 4.91 | 4.99 | 4.80 | 4.87 | 4.90 | 4.97 | 4.90 | 4.83 | 4.85 | |
| 75 | 20 | TC | 137.7 | 138.0 | 147.2 | 165.5 | 130.0 | 133.0 | 142.8 | 161.5 | 119.5 | 126.4 | 137.3 | 155.4 |
| | | SHC | 137.7 | 138.0 | 115.4 | 73.5 | 130.0 | 124.6 | 103.7 | 69.1 | 119.5 | 107.6 | 91.6 | 64.8 |
| | | LDB | 54.75 | 54.83 | 59.06 | 66.70 | 50.21 | 51.59 | 56.50 | 64.39 | 43.49 | 47.31 | 52.34 | 60.54 |
| | | LWB | 46.21 | 52.32 | 57.75 | 66.32 | 44.02 | 50.09 | 55.53 | 64.18 | 40.62 | 46.41 | 51.76 | 60.61 |
| | | | KW | 6.36 | 6.40 | 6.40 | 6.54 | 6.29 | 6.30 | 6.39 | 6.58 | 6.40 | 6.38 | 6.43 |
| | 27 | TC | 138.7 | 138.9 | 147.8 | 166.6 | 130.9 | 133.6 | 143.9 | 162.6 | 119.6 | 127.1 | 137.5 | 156.1 |
| | | SHC | 138.7 | 138.9 | 115.4 | 73.9 | 130.9 | 124.7 | 104.0 | 69.7 | 119.6 | 107.9 | 91.6 | 64.7 |
| | | LDB | 54.58 | 54.68 | 59.07 | 66.64 | 50.00 | 51.57 | 56.43 | 64.27 | 43.46 | 47.23 | 52.33 | 60.57 |
| | | LWB | 46.12 | 52.26 | 57.70 | 66.26 | 43.91 | 50.03 | 55.44 | 64.10 | 40.60 | 46.30 | 51.74 | 60.53 |
| | | | KW | 6.07 | 6.02 | 6.16 | 6.22 | 6.06 | 6.02 | 6.11 | 6.24 | 6.02 | 5.99 | 6.09 |
| | 33 | TC | 139.3 | 139.6 | 147.9 | 167.7 | 131.6 | 134.4 | 144.5 | 163.6 | 120.0 | 127.1 | 138.2 | 156.4 |
| | | SHC | 139.3 | 139.6 | 115.5 | 74.3 | 131.6 | 125.0 | 104.4 | 69.9 | 120.0 | 108.0 | 91.9 | 64.8 |
| LDB | | 54.46 | 54.54 | 59.04 | 66.57 | 49.85 | 51.50 | 56.35 | 64.22 | 43.33 | 47.21 | 52.24 | 60.54 | |
| LWB | | 46.07 | 52.20 | 57.70 | 66.20 | 43.84 | 49.96 | 55.38 | 64.02 | 40.54 | 46.30 | 51.65 | 60.50 | |
| | | KW | 5.88 | 5.90 | 5.89 | 6.09 | 5.92 | 5.90 | 5.89 | 6.08 | 5.95 | 5.89 | 5.88 | |
| 40 | TC | 139.9 | 140.0 | 149.0 | 169.0 | 131.7 | 134.7 | 145.5 | 163.9 | 120.1 | 127.3 | 138.7 | 156.8 | |
| | SHC | 139.9 | 140.0 | 116.0 | 74.8 | 131.7 | 125.3 | 104.6 | 69.9 | 120.1 | 108.3 | 92.3 | 65.4 | |
| | LDB | 54.36 | 54.47 | 58.95 | 66.47 | 49.81 | 51.45 | 56.25 | 64.21 | 43.30 | 47.12 | 52.14 | 60.34 | |
| | LWB | 46.02 | 52.17 | 57.62 | 66.12 | 43.82 | 49.93 | 55.28 | 64.00 | 40.52 | 46.28 | 51.59 | 60.46 | |
| | | KW | 5.80 | 5.78 | 5.83 | 5.92 | 5.72 | 5.75 | 5.77 | 5.83 | 5.82 | 5.74 | 5.80 | |
| 85 | 20 | TC | 133.8 | 133.4 | 141.9 | 158.9 | 126.3 | 127.6 | 137.3 | 154.7 | 115.2 | 121.8 | 132.4 | 150.2 |
| | | SHC | 133.8 | 133.4 | 113.2 | 71.4 | 126.3 | 121.7 | 101.4 | 66.7 | 115.2 | 105.4 | 89.4 | 62.5 |
| | | LDB | 55.47 | 55.66 | 59.47 | 67.09 | 51.06 | 52.26 | 57.01 | 64.92 | 44.81 | 47.98 | 52.99 | 61.22 |
| | | LWB | 46.54 | 52.67 | 58.11 | 66.70 | 44.43 | 50.64 | 56.02 | 64.69 | 41.30 | 47.06 | 52.39 | 61.17 |
| | | | KW | 7.49 | 7.43 | 7.56 | 7.65 | 7.47 | 7.38 | 7.46 | 7.59 | 7.37 | 7.49 | 7.50 |
| | 27 | TC | 134.2 | 134.4 | 142.7 | 161.5 | 126.9 | 129.1 | 139.0 | 157.5 | 115.5 | 122.2 | 132.7 | 150.6 |
| | | SHC | 134.2 | 134.4 | 113.5 | 72.2 | 126.9 | 122.3 | 102.0 | 67.8 | 115.5 | 105.5 | 89.5 | 62.6 |
| | | LDB | 55.39 | 55.49 | 59.42 | 66.93 | 50.91 | 52.12 | 56.87 | 64.69 | 44.71 | 47.95 | 52.97 | 61.19 |
| | | LWB | 46.51 | 52.60 | 58.06 | 66.56 | 44.36 | 50.48 | 55.87 | 64.48 | 41.25 | 47.00 | 52.36 | 61.13 |
| | | | KW | 7.07 | 7.07 | 7.22 | 7.38 | 7.14 | 7.18 | 7.22 | 7.36 | 7.10 | 7.15 | 7.24 |
| | 33 | TC | 135.2 | 135.7 | 144.3 | 162.3 | 126.9 | 129.8 | 140.1 | 157.7 | 115.6 | 122.4 | 133.4 | 152.0 |
| | | SHC | 135.2 | 135.7 | 114.3 | 72.5 | 126.9 | 122.6 | 102.5 | 67.8 | 115.6 | 105.6 | 90.0 | 63.1 |
| LDB | | 55.21 | 55.25 | 59.27 | 66.90 | 50.91 | 52.05 | 56.77 | 64.68 | 44.69 | 47.91 | 52.83 | 61.02 | |
| LWB | | 46.42 | 52.50 | 57.95 | 66.51 | 44.36 | 50.42 | 55.78 | 64.47 | 41.24 | 46.97 | 52.27 | 60.98 | |
| | | KW | 7.02 | 6.90 | 6.99 | 6.98 | 6.83 | 7.03 | 7.04 | 6.98 | 6.94 | 7.00 | 7.00 | |
| 40 | TC | 136.8 | 135.8 | 145.2 | 162.6 | 127.8 | 131.3 | 140.9 | 159.7 | 116.2 | 122.5 | 133.5 | 152.4 | |
| | SHC | 136.8 | 135.8 | 114.8 | 72.6 | 127.8 | 124.0 | 103.1 | 68.5 | 116.2 | 106.0 | 89.8 | 63.3 | |
| | LDB | 54.92 | 55.24 | 59.18 | 66.86 | 50.72 | 51.75 | 56.64 | 64.52 | 44.50 | 47.82 | 52.87 | 60.96 | |
| | LWB | 46.29 | 52.49 | 57.88 | 66.49 | 44.27 | 50.27 | 55.70 | 64.32 | 41.14 | 46.95 | 52.26 | 60.94 | |
| | | KW | 6.76 | 6.87 | 6.89 | 6.84 | 6.84 | 6.82 | 6.87 | 6.90 | 6.68 | 6.84 | 6.78 | |



GROSS COOLING CAPACITIES (cont)

50XCW12 (10 TONS) (cont)

| Entering Condenser Water | | BF | AIR ENTERING EVAPORATOR — CFM AT 80 F EDB | | | | | | | | | | | |
|--------------------------|-----|-------|---|-------|-------|-------|-------|-------|-------|-------|-------|-------|-------|-------|
| TEMP (F) | GPM | | 5000 | | | | 4000 | | | | 3000 | | | |
| | | | Air Entering Evaporator — Ewb (F) | | | | | | | | | | | |
| | | | 57 | 62 | 67 | 75 | 57 | 62 | 67 | 75 | 57 | 62 | 67 | 75 |
| | | | 0.42 | 0.17 | 0.11 | 0.10 | 0.32 | 0.10 | 0.09 | 0.06 | 0.17 | 0.06 | 0.06 | 0.01 |
| 95 | 20 | TC | 128.6 | 129.3 | 135.4 | 153.0 | 121.7 | 122.9 | 132.4 | 149.4 | 110.7 | 116.7 | 127.1 | 143.4 |
| | | SHC | 128.6 | 129.3 | 110.5 | 69.3 | 121.7 | 118.8 | 99.3 | 64.9 | 110.7 | 103.2 | 87.0 | 60.1 |
| | | LDB | 56.42 | 56.43 | 59.95 | 67.46 | 52.11 | 52.92 | 57.49 | 65.33 | 46.17 | 48.65 | 53.71 | 61.92 |
| | | LWB | 46.99 | 52.99 | 58.56 | 67.04 | 44.94 | 51.10 | 56.46 | 65.09 | 42.00 | 47.78 | 53.07 | 61.89 |
| | 27 | TC | 128.7 | 130.4 | 135.8 | 153.2 | 122.3 | 123.1 | 133.0 | 150.6 | 112.0 | 116.7 | 127.1 | 144.2 |
| | | SHC | 128.7 | 130.3 | 110.9 | 69.4 | 122.3 | 119.6 | 99.7 | 65.3 | 112.0 | 102.8 | 87.3 | 60.3 |
| | | LDB | 56.41 | 56.21 | 59.88 | 67.44 | 51.96 | 52.74 | 57.40 | 65.25 | 45.77 | 48.77 | 53.64 | 61.88 |
| | | LWB | 46.99 | 52.90 | 58.53 | 67.03 | 44.87 | 51.08 | 56.41 | 65.00 | 41.79 | 47.78 | 53.07 | 61.81 |
| | 33 | TC | 130.5 | 130.5 | 137.7 | 155.5 | 122.3 | 123.5 | 133.9 | 151.6 | 112.0 | 117.4 | 127.5 | 145.5 |
| | | SHC | 130.5 | 130.5 | 111.4 | 70.2 | 122.3 | 119.4 | 100.2 | 65.7 | 112.0 | 103.2 | 87.2 | 60.7 |
| | | LDB | 56.08 | 56.21 | 59.79 | 67.31 | 51.96 | 52.78 | 57.30 | 65.16 | 45.77 | 48.66 | 53.65 | 61.74 |
| | | LWB | 46.83 | 52.90 | 58.40 | 66.90 | 44.87 | 51.04 | 56.33 | 64.92 | 41.79 | 47.67 | 53.02 | 61.67 |
| 40 | TC | 130.9 | 130.5 | 138.3 | 156.1 | 123.3 | 123.5 | 134.5 | 153.0 | 112.3 | 117.7 | 127.6 | 146.0 | |
| | SHC | 130.9 | 130.4 | 111.6 | 70.5 | 123.3 | 119.8 | 100.1 | 66.2 | 112.3 | 103.3 | 87.3 | 60.9 | |
| | LDB | 55.99 | 56.22 | 59.77 | 67.24 | 51.75 | 52.69 | 57.32 | 65.04 | 45.70 | 48.61 | 53.63 | 61.69 | |
| | LWB | 46.79 | 52.90 | 58.36 | 66.86 | 44.77 | 51.04 | 56.27 | 64.81 | 41.76 | 47.63 | 53.00 | 61.62 | |
| 100 | 20 | TC | 126.6 | 126.8 | 133.0 | 149.0 | 118.7 | 120.0 | 129.5 | 146.6 | 109.1 | 114.4 | 124.0 | 140.9 |
| | | SHC | 126.6 | 126.8 | 109.5 | 68.0 | 118.7 | 117.6 | 98.0 | 63.9 | 109.1 | 101.8 | 85.8 | 59.1 |
| | | LDB | 56.78 | 56.88 | 60.14 | 67.69 | 52.79 | 53.19 | 57.77 | 65.56 | 46.67 | 49.08 | 54.09 | 62.23 |
| | | LWB | 47.16 | 53.18 | 58.72 | 67.27 | 45.27 | 51.39 | 56.72 | 65.29 | 42.25 | 48.09 | 53.46 | 62.15 |
| | 27 | TC | 127.0 | 127.4 | 133.0 | 150.7 | 120.1 | 120.5 | 129.4 | 148.6 | 110.0 | 114.6 | 124.2 | 142.1 |
| | | SHC | 127.0 | 127.4 | 109.9 | 68.5 | 120.1 | 118.1 | 98.3 | 64.6 | 110.0 | 101.9 | 86.0 | 59.5 |
| | | LDB | 56.72 | 56.77 | 60.07 | 67.60 | 52.48 | 53.08 | 57.72 | 65.40 | 46.38 | 49.06 | 54.03 | 62.12 |
| | | LWB | 47.13 | 53.14 | 58.72 | 67.17 | 45.12 | 51.34 | 56.73 | 65.14 | 42.11 | 48.07 | 53.44 | 62.03 |
| | 33 | TC | 128.1 | 128.3 | 134.0 | 152.3 | 120.7 | 120.5 | 131.3 | 149.3 | 110.0 | 115.1 | 124.8 | 142.6 |
| | | SHC | 128.1 | 128.3 | 109.8 | 69.1 | 120.7 | 118.2 | 99.1 | 64.8 | 110.0 | 102.0 | 86.0 | 59.7 |
| | | LDB | 56.51 | 56.60 | 60.09 | 67.51 | 52.34 | 53.05 | 57.54 | 65.35 | 46.37 | 49.00 | 54.01 | 62.05 |
| | | LWB | 47.03 | 53.06 | 58.65 | 67.08 | 45.05 | 51.33 | 56.56 | 65.09 | 42.10 | 48.00 | 53.36 | 61.97 |
| 40 | TC | 128.2 | 128.6 | 135.2 | 154.0 | 121.3 | 121.7 | 131.6 | 149.6 | 110.1 | 116.0 | 125.3 | 143.0 | |
| | SHC | 128.2 | 124.8 | 110.2 | 69.9 | 121.3 | 118.3 | 98.8 | 65.0 | 110.1 | 102.7 | 86.3 | 59.8 | |
| | LDB | 56.50 | 57.23 | 60.01 | 67.36 | 52.20 | 53.02 | 57.59 | 65.32 | 46.37 | 48.81 | 53.94 | 62.01 | |
| | LWB | 47.03 | 53.04 | 58.57 | 66.98 | 44.99 | 51.22 | 56.53 | 65.07 | 42.10 | 47.88 | 53.30 | 61.93 | |
| | | | 8.76 | 8.73 | 8.76 | 8.64 | 8.67 | 8.52 | 8.49 | 8.88 | 8.57 | 8.65 | 8.57 | 8.62 |

LEGEND

- BF** — Bypass Factor
- EDB** — Entering Dry Bulb (F)
- EWB** — Entering Wet Bulb (F)
- LDB** — Leaving Dry Bulb (F)
- LWB** — Leaving Wet Bulb (F)
- SHC** — Sensible Capacity (1000 Btu/hr)
- TC** — Total Capacity (1000 Btu/hr)
- kW** — Compressor Motor Power Input (kilowatts)

Performance data (cont)



GROSS COOLING CAPACITIES (cont)

50XCW14 (12 TONS)

| Entering Condenser Water | | BF | AIR ENTERING EVAPORATOR — CFM AT 80 F EDB | | | | | | | | | | | |
|--------------------------|-----|-------|---|-------|-------|-------|-------|-------|-------|-------|-------|-------|-------|-------|
| TEMP (F) | GPM | | 6000 | | | | 4800 | | | | 3600 | | | |
| | | | Air Entering Evaporator — Ewb (F) | | | | | | | | | | | |
| | | | 57 | 62 | 67 | 75 | 57 | 62 | 67 | 75 | 57 | 62 | 67 | 75 |
| | | | 0.49 | 0.28 | 0.16 | 0.14 | 0.39 | 0.15 | 0.12 | 0.10 | 0.26 | 0.09 | 0.09 | 0.04 |
| 65 | 24 | TC | 148.7 | 150.9 | 156.5 | 176.6 | 141.1 | 141.8 | 152.3 | 172.6 | 130.0 | 137.0 | 145.9 | 165.3 |
| | | SHC | 148.7 | 141.8 | 127.3 | 80.2 | 141.1 | 136.9 | 114.7 | 75.1 | 130.0 | 119.9 | 100.6 | 69.5 |
| | | LDB | 57.28 | 58.45 | 60.75 | 67.91 | 53.05 | 53.99 | 58.33 | 65.85 | 46.89 | 49.66 | 54.67 | 62.56 |
| | | LWB | 47.39 | 53.26 | 58.90 | 67.37 | 45.40 | 51.57 | 56.96 | 65.50 | 42.37 | 48.13 | 53.77 | 62.48 |
| | | | KW | 5.57 | 5.52 | 5.53 | 5.46 | 5.65 | 5.58 | 5.54 | 5.45 | 5.73 | 5.59 | 5.56 |
| | 32 | TC | 149.7 | 151.4 | 157.9 | 178.8 | 141.4 | 143.7 | 153.6 | 173.8 | 130.4 | 137.1 | 147.0 | 167.4 |
| | | SHC | 149.7 | 151.3 | 127.7 | 80.9 | 141.4 | 137.1 | 114.9 | 75.6 | 130.4 | 120.0 | 100.9 | 70.4 |
| | | LDB | 57.13 | 56.98 | 60.70 | 67.81 | 53.00 | 53.89 | 58.30 | 65.77 | 46.79 | 49.62 | 54.59 | 62.36 |
| | | LWB | 47.32 | 53.22 | 58.82 | 67.27 | 45.37 | 51.39 | 56.86 | 65.42 | 42.32 | 48.11 | 53.65 | 62.30 |
| | | | KW | 5.34 | 5.24 | 5.31 | 5.19 | 5.36 | 5.34 | 5.33 | 5.23 | 5.46 | 5.45 | 5.35 |
| | 40 | TC | 150.4 | 151.7 | 158.9 | 179.8 | 142.0 | 144.1 | 154.5 | 175.7 | 131.5 | 134.5 | 147.8 | 168.3 |
| | | SHC | 150.4 | 147.5 | 128.1 | 81.2 | 142.0 | 138.2 | 115.3 | 76.1 | 131.5 | 119.0 | 101.3 | 70.7 |
| LDB | | 57.02 | 57.57 | 60.63 | 67.76 | 52.88 | 53.75 | 58.22 | 65.67 | 46.50 | 49.85 | 54.51 | 62.28 | |
| LWB | | 47.28 | 53.20 | 58.77 | 67.22 | 45.32 | 51.38 | 56.79 | 65.31 | 42.17 | 48.41 | 53.57 | 62.22 | |
| | | KW | 5.22 | 5.16 | 5.19 | 5.03 | 5.25 | 5.20 | 5.20 | 5.03 | 5.36 | 5.23 | 5.07 | |
| 48 | TC | 151.0 | 152.7 | 159.8 | 181.1 | 142.9 | 144.5 | 155.3 | 176.4 | 131.8 | 137.7 | 148.6 | 169.5 | |
| | SHC | 151.0 | 127.6 | 128.5 | 81.5 | 142.9 | 138.7 | 115.6 | 76.3 | 131.8 | 120.0 | 101.5 | 70.9 | |
| | LDB | 56.93 | 60.06 | 60.57 | 67.71 | 52.71 | 53.65 | 58.16 | 65.63 | 46.43 | 49.53 | 54.46 | 62.24 | |
| | LWB | 47.23 | 52.88 | 58.71 | 67.17 | 45.24 | 51.35 | 56.73 | 65.27 | 42.13 | 48.00 | 53.48 | 62.12 | |
| | | KW | 5.10 | 5.09 | 5.05 | 4.93 | 5.14 | 5.12 | 5.09 | 4.95 | 5.22 | 5.17 | 5.09 | |
| 75 | 24 | TC | 146.2 | 146.4 | 153.3 | 173.3 | 137.8 | 138.8 | 149.1 | 168.8 | 127.4 | 132.3 | 142.3 | 161.2 |
| | | SHC | 146.2 | 146.4 | 126.4 | 79.0 | 137.8 | 135.0 | 113.2 | 73.8 | 127.4 | 118.4 | 99.0 | 67.8 |
| | | LDB | 57.66 | 57.75 | 60.90 | 68.09 | 53.68 | 54.34 | 58.62 | 66.10 | 47.56 | 50.03 | 55.09 | 63.00 |
| | | LWB | 47.57 | 53.55 | 59.08 | 67.53 | 45.70 | 51.81 | 57.18 | 65.73 | 42.70 | 48.67 | 54.13 | 62.84 |
| | | | KW | 6.82 | 6.80 | 6.66 | 6.70 | 6.74 | 6.68 | 6.82 | 6.77 | 6.99 | 6.91 | 6.65 |
| | 32 | TC | 146.4 | 146.5 | 153.6 | 174.1 | 138.4 | 138.9 | 149.4 | 169.0 | 127.7 | 132.7 | 143.3 | 161.6 |
| | | SHC | 146.4 | 146.5 | 126.1 | 79.3 | 138.4 | 135.5 | 113.2 | 73.9 | 127.7 | 118.1 | 99.2 | 67.9 |
| | | LDB | 57.63 | 57.73 | 60.91 | 68.04 | 53.57 | 54.26 | 58.62 | 66.08 | 47.49 | 50.09 | 55.03 | 62.97 |
| | | LWB | 47.55 | 53.54 | 59.05 | 67.50 | 45.65 | 51.81 | 57.16 | 65.72 | 42.67 | 48.63 | 54.03 | 62.81 |
| | | | KW | 6.39 | 6.39 | 6.36 | 6.26 | 6.40 | 6.44 | 6.40 | 6.30 | 6.48 | 6.46 | 6.43 |
| | 40 | TC | 146.7 | 146.6 | 153.9 | 176.2 | 138.4 | 139.2 | 149.6 | 169.5 | 127.7 | 132.9 | 143.4 | 162.5 |
| | | SHC | 146.7 | 146.6 | 126.7 | 80.0 | 138.4 | 135.7 | 113.3 | 74.0 | 127.7 | 118.3 | 99.4 | 68.2 |
| LDB | | 57.59 | 57.73 | 60.85 | 67.94 | 53.56 | 54.22 | 58.60 | 66.06 | 47.48 | 50.06 | 54.98 | 62.89 | |
| LWB | | 47.54 | 53.54 | 59.04 | 67.39 | 45.64 | 51.78 | 57.15 | 65.69 | 42.66 | 48.61 | 54.02 | 62.72 | |
| | | KW | 6.18 | 6.19 | 6.16 | 6.15 | 6.28 | 6.22 | 6.14 | 6.02 | 6.38 | 6.32 | 6.29 | |
| 48 | TC | 148.8 | 149.1 | 154.3 | 176.4 | 141.3 | 139.7 | 152.7 | 173.0 | 129.7 | 135.3 | 144.9 | 162.7 | |
| | SHC | 148.8 | 149.1 | 125.1 | 80.2 | 141.3 | 136.1 | 114.9 | 75.2 | 129.7 | 119.6 | 100.2 | 68.3 | |
| | LDB | 57.26 | 57.34 | 61.04 | 67.92 | 53.01 | 54.14 | 58.29 | 65.83 | 46.98 | 49.73 | 54.78 | 62.87 | |
| | LWB | 47.39 | 53.38 | 59.00 | 67.38 | 45.38 | 51.74 | 56.92 | 65.48 | 42.41 | 48.33 | 53.86 | 62.71 | |
| | | KW | 6.02 | 6.04 | 6.00 | 5.92 | 6.31 | 6.09 | 6.02 | 5.93 | 6.22 | 6.19 | 6.06 | |
| 85 | 24 | TC | 141.7 | 141.8 | 147.9 | 166.6 | 134.2 | 135.1 | 143.8 | 162.9 | 124.0 | 128.4 | 138.9 | 156.8 |
| | | SHC | 141.7 | 141.8 | 123.8 | 76.7 | 134.2 | 133.6 | 111.1 | 71.7 | 124.0 | 116.3 | 97.5 | 66.2 |
| | | LDB | 58.35 | 58.45 | 61.29 | 68.44 | 54.37 | 54.62 | 59.02 | 66.50 | 48.44 | 50.55 | 55.45 | 63.40 |
| | | LWB | 47.89 | 53.84 | 59.38 | 67.84 | 46.03 | 52.12 | 57.57 | 66.09 | 43.14 | 49.12 | 54.49 | 63.21 |
| | | | KW | 8.10 | 8.13 | 8.09 | 7.87 | 8.01 | 7.94 | 7.87 | 8.04 | 8.10 | 8.00 | 8.10 |
| | 32 | TC | 141.9 | 142.0 | 148.2 | 167.3 | 134.8 | 135.1 | 144.0 | 163.3 | 124.2 | 128.8 | 139.3 | 157.7 |
| | | SHC | 141.9 | 142.0 | 124.0 | 76.9 | 134.8 | 135.1 | 111.1 | 71.8 | 124.2 | 116.2 | 97.6 | 66.5 |
| | | LDB | 58.32 | 58.42 | 61.27 | 68.41 | 54.25 | 54.33 | 59.02 | 66.47 | 48.37 | 50.58 | 55.43 | 63.31 |
| | | LWB | 47.87 | 53.82 | 59.37 | 67.81 | 45.97 | 52.11 | 57.56 | 66.06 | 43.11 | 49.08 | 54.45 | 63.14 |
| | | | KW | 7.58 | 7.57 | 7.53 | 7.38 | 7.57 | 7.58 | 7.49 | 7.46 | 7.70 | 7.73 | 7.64 |
| | 40 | TC | 143.3 | 142.7 | 149.0 | 167.4 | 134.9 | 135.2 | 145.4 | 164.3 | 124.3 | 128.7 | 139.9 | 158.3 |
| | | SHC | 143.3 | 142.7 | 124.2 | 77.1 | 134.9 | 135.2 | 111.7 | 72.2 | 124.3 | 116.3 | 97.9 | 66.7 |
| LDB | | 58.11 | 58.31 | 61.23 | 68.37 | 54.24 | 54.31 | 58.90 | 66.40 | 48.35 | 50.56 | 55.35 | 63.27 | |
| LWB | | 47.78 | 53.78 | 59.32 | 67.81 | 45.97 | 52.10 | 57.46 | 66.00 | 43.10 | 49.08 | 54.38 | 63.09 | |
| | | KW | 7.32 | 7.34 | 7.28 | 7.21 | 7.46 | 7.48 | 7.42 | 7.19 | 7.53 | 7.52 | 7.34 | |
| 48 | TC | 144.8 | 144.8 | 151.6 | 169.6 | 135.3 | 135.5 | 146.2 | 167.0 | 124.4 | 129.4 | 141.8 | 158.4 | |
| | SHC | 144.8 | 144.8 | 125.8 | 77.7 | 135.3 | 134.5 | 112.3 | 73.2 | 124.4 | 117.0 | 98.8 | 67.1 | |
| | LDB | 57.88 | 57.99 | 60.98 | 68.28 | 54.16 | 54.45 | 58.79 | 66.22 | 48.31 | 50.38 | 55.12 | 63.18 | |
| | LWB | 47.67 | 53.65 | 59.17 | 67.71 | 45.93 | 52.08 | 57.40 | 65.84 | 43.08 | 49.00 | 54.19 | 63.08 | |
| | | KW | 7.27 | 7.26 | 7.22 | 7.13 | 7.28 | 7.25 | 7.18 | 7.13 | 7.41 | 7.34 | 7.32 | |



GROSS COOLING CAPACITIES (cont)

50XCW14 (12 TONS) (cont)

| Entering Condenser Water | | BF | AIR ENTERING EVAPORATOR — CFM AT 80 F EDB | | | | | | | | | | | |
|--------------------------|-----|-------|---|-------|-------|-------|-------|-------|-------|-------|-------|-------|-------|-------|
| TEMP (F) | GPM | | 6000 | | | | 4800 | | | | 3600 | | | |
| | | | Air Entering Evaporator — Ewb (F) | | | | | | | | | | | |
| | | | 57 | 62 | 67 | 75 | 57 | 62 | 67 | 75 | 57 | 62 | 67 | 75 |
| | | | 0.49 | 0.28 | 0.16 | 0.14 | 0.39 | 0.15 | 0.12 | 0.10 | 0.26 | 0.09 | 0.09 | 0.04 |
| 95 | 24 | TC | 136.7 | 137.6 | 142.8 | 160.6 | 129.9 | 130.0 | 139.1 | 157.6 | 120.1 | 123.3 | 133.9 | 151.5 |
| | | SHC | 136.7 | 137.6 | 122.2 | 74.9 | 129.9 | 130.0 | 109.2 | 70.0 | 120.1 | 113.7 | 95.3 | 64.4 |
| | | LDB | 59.12 | 59.09 | 61.53 | 68.71 | 55.19 | 55.31 | 59.38 | 66.81 | 49.41 | 51.22 | 56.00 | 63.85 |
| | | LWB | 48.24 | 54.10 | 59.66 | 68.12 | 46.42 | 52.53 | 57.91 | 66.41 | 43.62 | 49.70 | 54.99 | 63.67 |
| | 32 | TC | 137.4 | 137.7 | 143.4 | 161.3 | 130.4 | 130.7 | 139.7 | 158.1 | 120.4 | 123.6 | 133.9 | 151.8 |
| | | SHC | 137.4 | 137.7 | 121.9 | 75.0 | 130.4 | 130.7 | 109.3 | 70.0 | 120.4 | 114.2 | 95.6 | 64.5 |
| | | LDB | 59.00 | 59.07 | 61.57 | 68.69 | 55.09 | 55.17 | 59.35 | 66.80 | 49.34 | 51.07 | 55.93 | 63.82 |
| | | LWB | 48.19 | 54.09 | 59.63 | 68.09 | 46.37 | 52.47 | 57.86 | 66.38 | 43.59 | 49.67 | 54.99 | 63.64 |
| | 40 | TC | 137.7 | 138.1 | 143.6 | 161.9 | 130.5 | 130.8 | 139.8 | 158.4 | 120.8 | 124.0 | 134.4 | 152.3 |
| | | SHC | 137.7 | 138.1 | 122.7 | 75.1 | 130.5 | 130.8 | 109.7 | 70.2 | 120.8 | 113.8 | 95.5 | 64.6 |
| | | LDB | 58.97 | 59.01 | 61.46 | 68.67 | 55.07 | 55.16 | 59.28 | 66.78 | 49.25 | 51.18 | 55.95 | 63.80 |
| | | LWB | 48.17 | 54.06 | 59.62 | 68.06 | 46.36 | 52.46 | 57.86 | 66.36 | 43.55 | 49.62 | 54.95 | 63.60 |
| 48 | TC | 138.1 | 138.2 | 143.8 | 162.4 | 131.1 | 131.0 | 140.1 | 158.5 | 121.4 | 124.5 | 134.4 | 153.1 | |
| | SHC | 138.1 | 138.2 | 122.1 | 75.3 | 131.1 | 131.0 | 109.5 | 70.2 | 121.4 | 114.1 | 95.6 | 64.8 | |
| | LDB | 58.89 | 59.00 | 61.54 | 68.65 | 54.97 | 55.11 | 59.31 | 66.77 | 49.10 | 51.10 | 55.93 | 63.73 | |
| | LWB | 48.14 | 54.06 | 59.61 | 68.04 | 46.31 | 52.44 | 57.84 | 66.35 | 43.47 | 49.56 | 54.94 | 63.53 | |
| 100 | 24 | TC | 134.8 | 134.9 | 139.7 | 157.9 | 128.3 | 127.4 | 136.6 | 154.1 | 118.1 | 121.0 | 131.2 | 148.9 |
| | | SHC | 134.8 | 134.9 | 120.7 | 73.8 | 128.3 | 127.4 | 108.4 | 68.8 | 118.1 | 112.5 | 94.2 | 63.3 |
| | | LDB | 59.41 | 59.50 | 61.76 | 68.87 | 55.50 | 55.79 | 59.52 | 67.03 | 49.93 | 51.51 | 56.28 | 64.11 |
| | | LWB | 48.37 | 54.27 | 59.84 | 68.25 | 46.56 | 52.73 | 58.09 | 66.62 | 43.88 | 49.95 | 55.26 | 63.89 |
| | 32 | TC | 135.1 | 135.1 | 140.0 | 158.1 | 128.7 | 128.2 | 136.8 | 154.8 | 118.5 | 121.1 | 131.5 | 149.2 |
| | | SHC | 135.1 | 135.1 | 120.8 | 74.0 | 128.7 | 128.2 | 108.1 | 68.9 | 118.5 | 112.9 | 94.5 | 63.5 |
| | | LDB | 59.36 | 59.46 | 61.75 | 68.85 | 55.43 | 55.64 | 59.59 | 67.01 | 49.83 | 51.40 | 56.20 | 64.06 |
| | | LWB | 48.35 | 54.25 | 59.82 | 68.24 | 46.53 | 52.67 | 58.07 | 66.58 | 43.83 | 49.94 | 55.24 | 63.86 |
| | 40 | TC | 135.5 | 135.6 | 140.6 | 158.9 | 128.7 | 128.6 | 137.2 | 155.1 | 118.8 | 121.5 | 131.8 | 149.9 |
| | | SHC | 135.5 | 135.6 | 120.8 | 74.1 | 128.7 | 128.6 | 108.2 | 69.1 | 118.8 | 112.7 | 94.4 | 63.7 |
| | | LDB | 59.30 | 59.39 | 61.74 | 68.83 | 55.42 | 55.57 | 59.55 | 66.99 | 49.76 | 51.46 | 56.23 | 64.01 |
| | | LWB | 48.32 | 54.22 | 59.79 | 68.20 | 46.52 | 52.64 | 58.05 | 66.56 | 43.80 | 49.90 | 55.21 | 63.80 |
| 48 | TC | 135.8 | 135.9 | 140.9 | 159.4 | 129.1 | 128.9 | 137.4 | 155.8 | 119.2 | 121.6 | 132.2 | 150.2 | |
| | SHC | 135.8 | 135.9 | 121.0 | 74.3 | 129.1 | 128.9 | 108.4 | 69.3 | 119.2 | 112.7 | 94.6 | 63.8 | |
| | LDB | 59.25 | 59.34 | 61.71 | 68.80 | 55.34 | 55.52 | 59.52 | 66.95 | 49.65 | 51.47 | 56.18 | 63.99 | |
| | LWB | 48.30 | 54.20 | 59.77 | 68.18 | 46.49 | 52.62 | 58.03 | 66.52 | 43.74 | 49.88 | 55.17 | 63.78 | |
| | | kW | 9.26 | 9.26 | 9.21 | 9.11 | 9.30 | 9.30 | 9.25 | 9.14 | 9.55 | 9.33 | 9.15 | |

LEGEND

- BF — Bypass Factor
- EDB — Entering Dry Bulb (F)
- EWB — Entering Wet Bulb (F)
- LDB — Leaving Dry Bulb (F)
- LWB — Leaving Wet Bulb (F)
- SHC — Sensible Capacity (1000 Btu/hr)
- TC — Total Capacity (1000 Btu/hr)
- kW — Compressor Motor Power Input (kilowatts)

Performance data (cont)



GROSS COOLING CAPACITIES (cont)

50XCW16 (15 TONS)

| Entering Condenser Water | | BF | AIR ENTERING EVAPORATOR — CFM AT 80 F EDB | | | | | | | | | | | |
|--------------------------|-----|-------|---|-------|-------|-------|-------|-------|-------|-------|-------|-------|-------|-------|
| TEMP (F) | GPM | | 7500 | | | | 6500 | | | | 4500 | | | |
| | | | Air Entering Evaporator — Ewb (F) | | | | | | | | | | | |
| | | | 57 | 62 | 67 | 75 | 57 | 62 | 67 | 75 | 57 | 62 | 67 | 75 |
| | | | 0.48 | 0.26 | 0.15 | 0.12 | 0.39 | 0.14 | 0.11 | 0.09 | 0.25 | 0.08 | 0.08 | 0.04 |
| 65 | 30 | TC | 189.4 | 189.9 | 195.0 | 225.5 | 179.6 | 180.6 | 193.9 | 220.2 | 165.4 | 171.0 | 185.7 | 211.6 |
| | | SHC | 189.4 | 189.7 | 173.6 | 102.2 | 179.6 | 174.0 | 145.3 | 95.8 | 165.4 | 150.7 | 127.9 | 88.6 |
| | | LDB | 56.85 | 56.91 | 58.89 | 67.67 | 52.56 | 53.54 | 58.04 | 65.57 | 46.30 | 49.44 | 54.23 | 62.23 |
| | | LWB | 47.19 | 53.18 | 52.93 | 67.20 | 45.16 | 51.35 | 56.74 | 65.28 | 42.07 | 48.14 | 53.49 | 62.14 |
| | 40 | TC | 190.5 | 193.1 | 199.7 | 228.4 | 180.8 | 181.8 | 195.9 | 223.0 | 165.8 | 172.3 | 187.2 | 214.4 |
| | | SHC | 190.5 | 192.9 | 162.0 | 103.1 | 180.8 | 174.8 | 146.4 | 96.7 | 165.8 | 151.4 | 128.2 | 89.5 |
| | | LDB | 56.71 | 56.51 | 60.41 | 67.57 | 52.37 | 53.44 | 57.87 | 65.43 | 46.24 | 49.35 | 54.19 | 62.05 |
| | | LWB | 47.13 | 53.02 | 58.71 | 67.09 | 45.07 | 51.28 | 56.63 | 65.14 | 42.03 | 48.04 | 53.36 | 61.94 |
| | 50 | TC | 191.5 | 193.7 | 203.4 | 230.4 | 181.0 | 183.6 | 197.3 | 224.5 | 165.9 | 173.0 | 188.4 | 214.9 |
| | | SHC | 191.5 | 187.1 | 163.7 | 103.7 | 181.0 | 175.5 | 146.7 | 97.3 | 165.9 | 151.8 | 128.6 | 89.7 |
| | | LDB | 56.59 | 57.23 | 60.21 | 67.50 | 52.35 | 53.31 | 57.83 | 65.35 | 46.21 | 49.26 | 54.10 | 61.95 |
| | | LWB | 47.07 | 52.99 | 58.55 | 67.01 | 45.06 | 51.15 | 56.55 | 65.07 | 42.02 | 47.97 | 53.26 | 61.88 |
| 60 | TC | 192.7 | 195.0 | 204.5 | 231.7 | 182.3 | 184.3 | 198.5 | 225.2 | 165.9 | 173.9 | 189.6 | 216.0 | |
| | SHC | 192.7 | 173.6 | 163.8 | 104.1 | 182.3 | 175.9 | 147.5 | 97.5 | 165.9 | 152.3 | 129.5 | 90.1 | |
| | LDB | 56.45 | 58.89 | 60.20 | 67.45 | 52.15 | 53.27 | 57.71 | 65.31 | 46.20 | 49.17 | 53.93 | 61.93 | |
| | LWB | 47.01 | 52.93 | 58.50 | 66.96 | 44.96 | 51.11 | 56.47 | 65.03 | 42.02 | 47.88 | 53.16 | 61.83 | |
| 75 | 30 | TC | 185.5 | 185.8 | 195.3 | 219.8 | 175.4 | 176.8 | 186.5 | 215.0 | 161.1 | 168.5 | 180.9 | 206.9 |
| | | SHC | 185.5 | 185.8 | 160.1 | 100.1 | 175.4 | 172.6 | 142.0 | 94.1 | 161.1 | 149.6 | 125.3 | 87.2 |
| | | LDB | 57.33 | 57.41 | 60.65 | 67.93 | 53.20 | 53.77 | 58.54 | 65.83 | 47.18 | 49.71 | 54.77 | 62.50 |
| | | LWB | 47.42 | 53.41 | 58.91 | 67.41 | 45.47 | 51.60 | 57.18 | 65.53 | 42.51 | 48.39 | 53.89 | 62.47 |
| | 40 | TC | 185.6 | 186.0 | 196.7 | 220.4 | 175.9 | 177.1 | 188.3 | 216.0 | 161.4 | 168.7 | 180.9 | 207.2 |
| | | SHC | 185.6 | 186.0 | 160.0 | 100.3 | 175.9 | 172.6 | 142.9 | 94.3 | 161.4 | 149.7 | 125.5 | 86.9 |
| | | LDB | 57.32 | 57.38 | 60.64 | 67.90 | 53.13 | 53.77 | 58.40 | 65.78 | 47.13 | 49.67 | 54.73 | 62.57 |
| | | LWB | 47.41 | 53.39 | 58.84 | 67.39 | 45.44 | 51.58 | 57.07 | 65.49 | 42.48 | 48.37 | 53.88 | 62.44 |
| | 50 | TC | 186.3 | 186.1 | 195.7 | 221.6 | 175.9 | 177.3 | 189.4 | 219.5 | 161.9 | 169.1 | 181.9 | 209.2 |
| | | SHC | 186.3 | 186.1 | 160.1 | 101.0 | 175.9 | 172.8 | 143.5 | 95.6 | 161.9 | 149.9 | 125.8 | 87.7 |
| | | LDB | 57.22 | 57.37 | 60.63 | 67.82 | 53.12 | 53.74 | 58.31 | 65.60 | 47.02 | 49.63 | 54.67 | 62.42 |
| | | LWB | 47.37 | 53.39 | 58.89 | 67.34 | 45.43 | 51.57 | 57.01 | 65.32 | 42.43 | 48.33 | 53.81 | 62.31 |
| 60 | TC | 188.5 | 190.1 | 200.6 | 225.6 | 179.4 | 178.8 | 190.6 | 220.9 | 162.6 | 172.0 | 182.5 | 212.0 | |
| | SHC | 188.5 | 190.1 | 162.9 | 102.2 | 179.4 | 174.4 | 143.9 | 96.0 | 162.6 | 151.6 | 126.1 | 88.7 | |
| | LDB | 56.96 | 56.89 | 60.30 | 67.68 | 52.59 | 53.49 | 58.26 | 65.54 | 46.88 | 49.29 | 54.60 | 62.22 | |
| | LWB | 47.24 | 53.19 | 58.67 | 67.20 | 45.18 | 51.47 | 56.94 | 65.25 | 42.36 | 48.06 | 53.75 | 62.11 | |
| 85 | 30 | TC | 180.0 | 179.8 | 188.0 | 211.2 | 170.0 | 170.0 | 183.4 | 207.5 | 156.6 | 162.6 | 176.0 | 199.7 |
| | | SHC | 180.0 | 179.8 | 157.9 | 97.6 | 170.0 | 170.0 | 141.6 | 91.2 | 156.5 | 146.8 | 123.6 | 84.2 |
| | | LDB | 58.00 | 58.14 | 60.90 | 68.23 | 54.03 | 54.17 | 58.59 | 66.25 | 48.11 | 50.27 | 55.10 | 63.10 |
| | | LWB | 47.72 | 53.71 | 59.24 | 67.74 | 45.87 | 52.04 | 57.36 | 65.90 | 42.98 | 48.93 | 54.29 | 62.97 |
| | 40 | TC | 180.2 | 180.2 | 188.4 | 211.9 | 170.5 | 170.9 | 183.5 | 207.5 | 156.8 | 162.8 | 176.2 | 201.6 |
| | | SHC | 180.2 | 180.2 | 157.3 | 97.6 | 170.5 | 170.9 | 141.0 | 91.4 | 156.8 | 146.9 | 123.4 | 85.1 |
| | | LDB | 57.98 | 58.09 | 60.98 | 68.23 | 53.95 | 54.02 | 58.69 | 66.22 | 48.05 | 50.24 | 55.15 | 62.94 |
| | | LWB | 47.72 | 53.69 | 59.23 | 67.71 | 45.83 | 51.98 | 57.36 | 65.90 | 42.95 | 48.91 | 54.28 | 62.84 |
| | 50 | TC | 180.2 | 180.2 | 188.9 | 214.0 | 170.5 | 171.1 | 183.6 | 208.6 | 157.0 | 163.4 | 176.3 | 201.6 |
| | | SHC | 180.2 | 180.2 | 157.6 | 98.5 | 170.5 | 170.0 | 141.1 | 91.6 | 157.0 | 147.2 | 123.5 | 84.9 |
| | | LDB | 57.97 | 58.08 | 60.95 | 68.12 | 53.95 | 54.16 | 58.67 | 66.19 | 48.02 | 50.19 | 55.13 | 62.97 |
| | | LWB | 47.71 | 53.69 | 59.20 | 67.63 | 45.83 | 51.97 | 57.35 | 65.85 | 42.93 | 48.85 | 54.27 | 62.83 |
| 60 | TC | 181.0 | 181.8 | 189.5 | 215.4 | 171.5 | 171.7 | 188.7 | 209.4 | 157.2 | 166.2 | 177.1 | 203.0 | |
| | SHC | 181.0 | 181.8 | 157.8 | 98.9 | 171.5 | 169.7 | 143.7 | 91.9 | 157.2 | 148.9 | 123.8 | 85.4 | |
| | LDB | 57.88 | 57.89 | 60.92 | 68.07 | 53.80 | 54.21 | 58.29 | 66.15 | 47.98 | 49.84 | 55.07 | 62.86 | |
| | LWB | 47.67 | 53.61 | 59.17 | 67.58 | 45.76 | 51.93 | 57.05 | 65.81 | 42.91 | 48.59 | 54.20 | 62.73 | |
| | | KW | 8.10 | 8.06 | 8.20 | 8.52 | 8.04 | 7.98 | 8.10 | 8.47 | 7.93 | 8.02 | 8.37 | |
| | | KW | 7.86 | 7.81 | 7.81 | 8.26 | 7.70 | 7.76 | 7.89 | 8.13 | 7.64 | 7.66 | 7.81 | 8.16 |
| | | KW | 7.73 | 7.67 | 7.77 | 7.96 | 7.60 | 7.56 | 7.75 | 7.95 | 7.44 | 7.52 | 7.68 | 7.89 |
| | | KW | 7.56 | 7.57 | 7.66 | 7.90 | 7.46 | 7.49 | 7.64 | 7.84 | 7.39 | 7.44 | 7.53 | 7.79 |
| | | KW | 9.34 | 9.39 | 9.58 | 9.90 | 9.34 | 9.19 | 9.20 | 9.87 | 9.05 | 9.26 | 9.23 | 9.76 |
| | | KW | 8.96 | 8.94 | 9.07 | 9.26 | 8.89 | 8.89 | 8.99 | 9.45 | 8.76 | 8.84 | 8.90 | 9.23 |
| | | KW | 8.68 | 8.80 | 8.87 | 9.10 | 8.64 | 8.67 | 8.71 | 8.84 | 8.56 | 8.67 | 8.74 | 9.00 |
| | | KW | 8.64 | 8.60 | 8.71 | 8.93 | 8.51 | 8.53 | 8.65 | 8.88 | 8.50 | 8.56 | 8.62 | 8.75 |
| | | KW | 10.54 | 10.64 | 10.63 | 10.73 | 10.52 | 10.32 | 10.57 | 10.89 | 10.45 | 10.58 | 10.60 | 10.94 |
| | | KW | 10.24 | 10.24 | 10.33 | 10.58 | 10.15 | 10.15 | 10.28 | 10.53 | 10.01 | 10.04 | 10.20 | 10.36 |
| | | KW | 9.96 | 9.95 | 10.13 | 10.39 | 9.87 | 9.89 | 9.98 | 10.13 | 9.86 | 9.94 | 9.94 | 10.14 |
| | | KW | 9.79 | 9.87 | 9.99 | 9.91 | 9.85 | 9.77 | 9.98 | 10.12 | 9.68 | 9.81 | 9.90 | 10.12 |



GROSS COOLING CAPACITIES (cont)

50XCW16 (15 TONS) (cont)

| Entering Condenser Water | | BF | AIR ENTERING EVAPORATOR — CFM AT 80 F EDB | | | | | | | | | | | |
|--------------------------|-----|-------|---|-------|-------|-------|-------|-------|-------|-------|-------|-------|-------|-------|
| TEMP (F) | GPM | | 7500 | | | | 6500 | | | | 4500 | | | |
| | | | Air Entering Evaporator — Ewb (F) | | | | | | | | | | | |
| | | | 57 | 62 | 67 | 75 | 57 | 62 | 67 | 75 | 57 | 62 | 67 | 75 |
| | | | 0.48 | 0.26 | 0.15 | 0.12 | 0.39 | 0.14 | 0.11 | 0.09 | 0.25 | 0.08 | 0.08 | 0.04 |
| 95 | 30 | TC | 172.7 | 174.5 | 181.3 | 204.7 | 165.0 | 164.4 | 177.0 | 200.6 | 151.2 | 156.0 | 169.5 | 192.8 |
| | | SHC | 172.7 | 174.5 | 155.1 | 95.5 | 165.0 | 164.4 | 138.4 | 88.9 | 151.2 | 144.2 | 120.9 | 81.9 |
| | | LDB | 58.89 | 58.78 | 61.25 | 68.49 | 54.79 | 55.02 | 59.08 | 66.61 | 49.20 | 50.78 | 55.64 | 63.57 |
| | | LWB | 48.13 | 53.97 | 59.54 | 67.98 | 46.23 | 52.40 | 57.73 | 66.23 | 43.52 | 49.52 | 54.82 | 63.43 |
| | 40 | TC | 173.9 | 174.7 | 181.4 | 205.3 | 165.1 | 165.2 | 177.0 | 200.9 | 151.8 | 156.6 | 170.0 | 193.6 |
| | | SHC | 173.9 | 174.7 | 154.7 | 95.3 | 165.1 | 165.2 | 139.0 | 89.2 | 151.8 | 143.8 | 120.7 | 82.0 |
| | | LDB | 58.74 | 58.76 | 61.30 | 68.50 | 54.77 | 54.89 | 59.00 | 66.56 | 49.08 | 50.87 | 55.68 | 63.55 |
| | | LWB | 48.07 | 53.96 | 59.54 | 67.95 | 46.22 | 52.35 | 57.73 | 66.22 | 43.46 | 49.47 | 54.78 | 63.38 |
| | 50 | TC | 174.9 | 175.1 | 182.1 | 206.0 | 165.2 | 165.7 | 177.4 | 201.4 | 152.3 | 156.7 | 170.3 | 193.8 |
| | | SHC | 174.9 | 175.1 | 154.9 | 95.6 | 165.2 | 165.7 | 138.6 | 89.2 | 152.3 | 143.9 | 120.9 | 82.1 |
| | | LDB | 58.63 | 58.71 | 61.27 | 68.47 | 54.76 | 54.81 | 59.05 | 66.56 | 48.98 | 50.84 | 55.64 | 63.52 |
| | | LWB | 48.02 | 53.94 | 59.51 | 67.93 | 46.21 | 52.32 | 57.71 | 66.19 | 43.41 | 49.47 | 54.76 | 63.36 |
| 60 | TC | 175.3 | 175.4 | 182.1 | 206.5 | 168.8 | 166.2 | 178.0 | 202.1 | 152.4 | 157.4 | 170.9 | 194.7 | |
| | SHC | 175.3 | 175.4 | 155.0 | 95.7 | 168.8 | 166.2 | 138.9 | 89.4 | 152.4 | 144.3 | 121.1 | 82.4 | |
| | LDB | 58.58 | 58.67 | 61.26 | 68.45 | 54.21 | 54.75 | 59.01 | 66.53 | 48.95 | 50.76 | 55.60 | 63.47 | |
| | LWB | 47.99 | 53.93 | 59.50 | 67.91 | 45.96 | 52.29 | 57.67 | 66.16 | 43.40 | 49.40 | 54.71 | 63.31 | |
| 100 | 30 | TC | 171.3 | 170.5 | 177.5 | 201.4 | 159.6 | 161.8 | 173.4 | 196.9 | 149.1 | 152.9 | 166.5 | 189.8 |
| | | SHC | 171.3 | 170.5 | 153.7 | 94.2 | 159.6 | 161.8 | 137.4 | 87.6 | 149.1 | 142.6 | 119.5 | 80.7 |
| | | LDB | 59.06 | 59.26 | 61.42 | 68.64 | 55.62 | 55.41 | 59.23 | 66.79 | 49.62 | 51.12 | 55.92 | 63.81 |
| | | LWB | 48.21 | 54.17 | 59.71 | 68.10 | 46.62 | 52.57 | 57.94 | 66.41 | 43.73 | 49.80 | 55.07 | 63.64 |
| | 40 | TC | 171.7 | 172.2 | 177.8 | 201.4 | 162.4 | 162.1 | 173.7 | 196.9 | 149.6 | 153.2 | 166.5 | 190.4 |
| | | SHC | 171.7 | 172.2 | 153.1 | 94.0 | 162.4 | 162.1 | 137.1 | 87.8 | 149.6 | 142.2 | 119.3 | 80.9 |
| | | LDB | 59.02 | 59.06 | 61.49 | 68.66 | 55.19 | 55.37 | 59.28 | 66.77 | 49.53 | 51.19 | 55.97 | 63.76 |
| | | LWB | 48.19 | 54.09 | 59.70 | 68.10 | 46.42 | 52.55 | 57.92 | 66.41 | 43.68 | 49.78 | 55.06 | 63.60 |
| | 50 | TC | 172.0 | 171.2 | 178.2 | 201.9 | 162.5 | 163.0 | 173.9 | 197.7 | 149.7 | 153.8 | 167.0 | 190.4 |
| | | SHC | 172.0 | 171.2 | 153.4 | 94.3 | 162.5 | 163.0 | 137.3 | 87.9 | 149.7 | 142.4 | 119.5 | 80.9 |
| | | LDB | 58.98 | 59.18 | 61.46 | 68.63 | 55.17 | 55.22 | 59.26 | 66.75 | 49.50 | 51.15 | 55.92 | 63.77 |
| | | LWB | 48.18 | 54.14 | 59.68 | 68.08 | 46.41 | 52.49 | 57.91 | 66.37 | 43.67 | 49.73 | 55.03 | 63.60 |
| 60 | TC | 172.3 | 172.5 | 179.0 | 202.9 | 163.0 | 163.3 | 174.5 | 198.3 | 149.9 | 154.0 | 167.6 | 191.1 | |
| | SHC | 172.3 | 172.5 | 153.7 | 94.5 | 163.0 | 163.3 | 137.4 | 88.1 | 149.9 | 142.6 | 119.8 | 81.1 | |
| | LDB | 58.95 | 59.03 | 61.42 | 68.60 | 55.10 | 55.18 | 59.23 | 66.72 | 49.47 | 51.12 | 55.87 | 63.72 | |
| | LWB | 48.16 | 54.07 | 59.64 | 68.04 | 46.37 | 52.47 | 57.87 | 66.35 | 43.65 | 49.71 | 54.98 | 63.55 | |
| | | kw | 11.97 | 12.00 | 11.99 | 12.36 | 11.95 | 11.96 | 12.07 | 12.24 | 11.89 | 11.85 | 11.97 | 12.20 |

LEGEND

- BF** — Bypass Factor
- EDB** — Entering Dry Bulb (F)
- EWB** — Entering Wet Bulb (F)
- LDB** — Leaving Dry Bulb (F)
- LWB** — Leaving Wet Bulb (F)
- SHC** — Sensible Capacity (1000 Btu/hr)
- TC** — Total Capacity (1000 Btu/hr)
- kw** — Compressor Motor Power Input (kilowatts)

Performance data (cont)



GROSS COOLING CAPACITIES (cont)

50XCW24 (20 TONS)

| Entering Condenser Water | | BF | AIR ENTERING EVAPORATOR — 80 F Edb (F) - CFM | | | | | | | | | | | |
|--------------------------|------|-------|--|-------|-------|-------|-------|-------|-------|-------|-------|-------|-------|-------|
| TEMP (F) | GPM | | 10,000 | | | | 8,000 | | | | 6,000 | | | |
| | | | Air Entering Evaporator — Ewb (F) | | | | | | | | | | | |
| | | | 57 | 62 | 67 | 75 | 57 | 62 | 67 | 75 | 57 | 62 | 67 | 75 |
| 0.43 | 0.22 | 0.20 | 0.17 | 0.32 | 0.17 | 0.16 | 0.11 | 0.17 | 0.12 | 0.12 | 0.12 | 0.03 | | |
| 65 | 40 | TC | 70.7 | 72.0 | 77.2 | 86.7 | 66.7 | 69.6 | 74.8 | 84.1 | 60.5 | 65.5 | 70.9 | 80.5 |
| | | SHC | 70.7 | 67.8 | 56.4 | 37.4 | 66.7 | 61.2 | 51.6 | 35.6 | 60.5 | 52.7 | 45.8 | 33.3 |
| | | LDB | 54.05 | 55.26 | 59.52 | 66.45 | 49.38 | 52.07 | 56.60 | 63.91 | 42.95 | 47.95 | 52.28 | 59.96 |
| | | LWB | 45.85 | 51.82 | 57.21 | 65.82 | 43.59 | 49.45 | 54.88 | 63.63 | 40.33 | 45.70 | 51.13 | 59.96 |
| | 53 | TC | 71.2 | 72.6 | 78.1 | 87.8 | 66.8 | 69.7 | 75.1 | 84.3 | 61.1 | 65.9 | 71.4 | 81.4 |
| | | SHC | 71.2 | 68.0 | 56.7 | 37.9 | 66.8 | 60.7 | 51.7 | 35.5 | 61.1 | 53.7 | 46.2 | 33.6 |
| | | LDB | 53.87 | 55.18 | 59.40 | 66.28 | 49.36 | 52.30 | 56.55 | 63.93 | 42.60 | 47.34 | 52.10 | 59.77 |
| | | LWB | 45.77 | 51.72 | 57.08 | 65.71 | 43.58 | 49.41 | 54.83 | 63.61 | 40.14 | 45.58 | 51.03 | 59.76 |
| | 67 | TC | 71.5 | 73.0 | 78.4 | 88.0 | 67.0 | 69.9 | 75.5 | 85.5 | 61.3 | 66.2 | 71.7 | 81.8 |
| | | SHC | 71.5 | 68.0 | 56.9 | 37.9 | 67.0 | 61.4 | 51.8 | 35.7 | 61.3 | 53.8 | 46.2 | 33.7 |
| | | LDB | 53.76 | 55.10 | 59.34 | 66.26 | 49.24 | 52.01 | 56.52 | 63.86 | 42.47 | 47.28 | 52.06 | 59.69 |
| | | LWB | 45.72 | 51.65 | 57.04 | 65.67 | 43.52 | 49.38 | 54.76 | 63.42 | 40.08 | 45.50 | 50.95 | 59.68 |
| 80 | TC | 71.9 | 73.3 | 78.7 | 88.7 | 67.4 | 70.4 | 75.7 | 85.9 | 61.6 | 66.4 | 71.9 | 81.9 | |
| | SHC | 71.9 | 68.4 | 57.0 | 38.1 | 67.4 | 61.6 | 51.8 | 36.1 | 61.6 | 53.9 | 46.3 | 33.8 | |
| | LDB | 53.63 | 55.04 | 59.31 | 66.20 | 49.10 | 51.90 | 56.49 | 63.66 | 42.29 | 47.22 | 52.01 | 59.67 | |
| | LWB | 45.65 | 51.63 | 57.00 | 65.59 | 43.45 | 49.28 | 54.73 | 63.36 | 39.98 | 45.44 | 50.89 | 59.67 | |
| 75 | 40 | TC | 68.4 | 69.5 | 74.5 | 82.9 | 64.5 | 67.2 | 72.3 | 81.8 | 59.2 | 63.7 | 68.8 | 78.0 |
| | | SHC | 68.4 | 66.5 | 55.2 | 36.1 | 64.5 | 60.0 | 50.4 | 34.6 | 59.2 | 52.6 | 44.9 | 32.3 |
| | | LDB | 54.90 | 55.74 | 59.94 | 66.93 | 50.39 | 52.61 | 57.13 | 64.33 | 43.76 | 48.03 | 52.85 | 60.56 |
| | | LWB | 46.26 | 52.21 | 57.58 | 66.27 | 44.09 | 49.92 | 55.34 | 63.98 | 40.75 | 46.23 | 51.69 | 60.51 |
| | 53 | TC | 69.4 | 70.1 | 75.0 | 85.0 | 64.8 | 67.2 | 72.9 | 81.8 | 59.5 | 63.9 | 69.3 | 78.2 |
| | | SHC | 69.4 | 66.8 | 55.5 | 36.8 | 64.8 | 60.3 | 50.8 | 34.6 | 59.5 | 52.7 | 45.2 | 32.4 |
| | | LDB | 54.52 | 55.62 | 59.84 | 66.67 | 50.30 | 52.49 | 56.97 | 64.36 | 43.62 | 47.99 | 52.68 | 60.49 |
| | | LWB | 46.08 | 52.13 | 57.51 | 66.03 | 44.06 | 49.91 | 55.23 | 63.98 | 40.67 | 46.17 | 51.57 | 60.47 |
| | 67 | TC | 69.5 | 70.4 | 75.3 | 85.1 | 64.8 | 67.5 | 73.0 | 82.1 | 59.5 | 64.0 | 69.5 | 79.1 |
| | | SHC | 69.5 | 66.9 | 55.7 | 36.9 | 64.8 | 60.2 | 50.6 | 34.7 | 59.5 | 52.8 | 45.2 | 32.8 |
| | | LDB | 54.50 | 55.58 | 59.79 | 66.64 | 50.26 | 52.52 | 57.02 | 64.31 | 43.62 | 47.88 | 52.69 | 60.23 |
| | | LWB | 46.07 | 52.08 | 57.48 | 66.02 | 44.03 | 49.86 | 55.21 | 63.94 | 40.67 | 46.14 | 51.52 | 60.27 |
| 80 | TC | 69.5 | 70.4 | 76.0 | 85.2 | 65.2 | 67.8 | 73.4 | 83.2 | 59.6 | 64.2 | 69.8 | 79.4 | |
| | SHC | 69.5 | 66.8 | 56.1 | 36.9 | 65.2 | 60.4 | 50.8 | 35.1 | 59.6 | 52.8 | 45.3 | 32.8 | |
| | LDB | 54.49 | 55.60 | 59.64 | 66.64 | 50.07 | 52.45 | 56.94 | 64.13 | 43.53 | 47.89 | 52.60 | 60.23 | |
| | LWB | 46.06 | 52.08 | 57.38 | 66.00 | 43.93 | 49.80 | 55.13 | 63.77 | 40.63 | 46.07 | 51.44 | 60.21 | |
| 85 | 40 | TC | 65.9 | 66.5 | 71.4 | 80.2 | 62.4 | 64.3 | 69.8 | 78.6 | 57.2 | 61.3 | 66.5 | 75.2 |
| | | SHC | 65.9 | 65.1 | 54.0 | 35.2 | 62.4 | 58.7 | 49.3 | 33.5 | 57.2 | 51.4 | 43.9 | 31.2 |
| | | LDB | 55.81 | 56.24 | 60.40 | 67.25 | 51.35 | 53.22 | 57.63 | 64.85 | 44.99 | 48.76 | 53.47 | 61.18 |
| | | LWB | 46.68 | 52.67 | 58.01 | 66.58 | 44.56 | 50.51 | 55.79 | 64.46 | 41.38 | 46.90 | 52.28 | 61.11 |
| | 53 | TC | 66.5 | 66.9 | 72.6 | 81.8 | 62.6 | 64.6 | 70.0 | 79.4 | 57.3 | 61.4 | 66.7 | 75.5 |
| | | SHC | 66.5 | 65.0 | 54.5 | 35.7 | 62.6 | 59.1 | 49.4 | 33.7 | 57.3 | 51.6 | 43.9 | 31.4 |
| | | LDB | 55.57 | 56.27 | 60.21 | 67.07 | 51.26 | 53.03 | 57.60 | 64.75 | 44.97 | 48.66 | 53.45 | 61.08 |
| | | LWB | 46.57 | 52.61 | 57.85 | 66.40 | 44.52 | 50.43 | 55.75 | 64.35 | 41.37 | 46.89 | 52.24 | 61.04 |
| | 67 | TC | 66.9 | 67.6 | 72.7 | 81.9 | 62.9 | 64.8 | 70.1 | 79.4 | 57.8 | 61.5 | 67.0 | 75.7 |
| | | SHC | 66.9 | 65.5 | 54.5 | 35.8 | 62.9 | 58.9 | 49.6 | 33.7 | 57.8 | 51.5 | 44.2 | 31.4 |
| | | LDB | 55.44 | 56.10 | 60.21 | 67.03 | 51.12 | 53.13 | 57.49 | 64.75 | 44.66 | 48.72 | 53.30 | 61.09 |
| | | LWB | 46.51 | 52.50 | 57.83 | 66.38 | 44.45 | 50.40 | 55.73 | 64.35 | 41.21 | 46.85 | 52.17 | 61.00 |
| 80 | TC | 67.1 | 67.7 | 73.2 | 82.2 | 63.0 | 65.1 | 70.6 | 79.9 | 58.0 | 62.0 | 67.1 | 76.1 | |
| | SHC | 67.1 | 65.2 | 55.0 | 35.8 | 63.0 | 59.1 | 49.6 | 33.9 | 58.0 | 51.7 | 44.1 | 31.5 | |
| | LDB | 55.35 | 56.19 | 60.03 | 67.02 | 51.10 | 53.06 | 57.50 | 64.65 | 44.51 | 48.58 | 53.33 | 61.00 | |
| | LWB | 46.47 | 52.49 | 57.77 | 66.35 | 44.44 | 50.35 | 55.64 | 64.27 | 41.14 | 46.70 | 52.13 | 60.92 | |
| | | KW | 3.66 | 3.66 | 3.85 | 3.65 | 3.68 | 3.67 | 3.58 | 3.75 | 3.75 | 3.68 | 3.62 | |



GROSS COOLING CAPACITIES (cont)

50XCW24 (20 TONS) (cont)

| Entering Condenser Water | | BF | AIR ENTERING EVAPORATOR — 80 F Edb (F) - CFM | | | | | | | | | | | | |
|--------------------------|-----|-------|--|-------|-------|-------|-------|-------|-------|-------|-------|-------|-------|-------|------|
| TEMP (F) | GPM | | 10,000 | | | | 8,000 | | | | 6,000 | | | | |
| | | | Air Entering Evaporator — Ewb (F) | | | | | | | | | | | | |
| | | | 57 | 62 | 67 | 75 | 57 | 62 | 67 | 75 | 57 | 62 | 67 | 75 | |
| | | | 0.43 | 0.22 | 0.20 | 0.17 | 0.32 | 0.17 | 0.16 | 0.11 | 0.17 | 0.12 | 0.12 | 0.03 | |
| 95 | 40 | TC | 62.9 | 64.2 | 68.3 | 76.7 | 60.2 | 61.5 | 67.6 | 74.5 | 55.3 | 58.7 | 63.7 | 72.1 | |
| | | SHC | 62.9 | 62.9 | 52.7 | 33.9 | 60.2 | 57.5 | 48.6 | 32.1 | 55.3 | 50.1 | 42.6 | 30.1 | |
| | | LDB | 56.89 | 57.05 | 60.88 | 67.71 | 52.39 | 53.78 | 57.92 | 65.48 | 46.17 | 49.56 | 54.22 | 61.88 | |
| | | LWB | 47.19 | 53.02 | 58.44 | 66.98 | 45.06 | 51.06 | 56.18 | 65.08 | 41.98 | 47.65 | 52.99 | 61.77 | |
| | | | KW | 4.59 | 4.74 | 4.67 | 4.78 | 4.71 | 4.67 | 4.68 | 4.66 | 4.74 | 4.70 | 4.69 | 4.68 |
| | 53 | TC | 63.4 | 64.3 | 69.0 | 77.0 | 60.2 | 61.7 | 66.8 | 75.2 | 55.5 | 58.7 | 64.0 | 72.6 | |
| | | SHC | 63.4 | 64.3 | 53.1 | 34.1 | 60.2 | 57.3 | 48.1 | 32.2 | 55.5 | 50.2 | 42.7 | 30.2 | |
| | | LDB | 56.71 | 56.53 | 60.73 | 67.65 | 52.38 | 53.85 | 58.18 | 65.40 | 46.04 | 49.47 | 54.19 | 61.80 | |
| | | LWB | 47.11 | 53.01 | 58.35 | 66.94 | 45.06 | 51.02 | 56.33 | 64.97 | 41.92 | 47.63 | 52.92 | 61.67 | |
| | | | KW | 4.38 | 4.56 | 4.51 | 4.34 | 4.49 | 4.47 | 4.47 | 4.44 | 4.59 | 4.49 | 4.48 | 4.45 |
| | 67 | TC | 64.0 | 64.8 | 69.2 | 77.9 | 60.7 | 62.2 | 67.0 | 75.5 | 55.5 | 59.1 | 64.3 | 72.7 | |
| | | SHC | 64.0 | 63.3 | 52.9 | 34.3 | 60.7 | 57.5 | 48.1 | 32.3 | 55.5 | 50.2 | 43.0 | 30.3 | |
| LDB | | 56.52 | 56.87 | 60.79 | 67.55 | 52.15 | 53.74 | 58.19 | 65.38 | 46.02 | 49.46 | 54.02 | 61.74 | | |
| LWB | | 47.02 | 52.94 | 58.32 | 66.84 | 44.95 | 50.92 | 56.29 | 64.94 | 41.91 | 47.55 | 52.85 | 61.65 | | |
| | | KW | 4.29 | 4.30 | 4.27 | 4.27 | 4.41 | 4.42 | 4.33 | 4.26 | 4.46 | 4.40 | 4.35 | 4.33 | |
| 80 | TC | 64.1 | 65.0 | 70.8 | 78.1 | 60.9 | 62.3 | 67.5 | 75.9 | 55.7 | 59.3 | 64.5 | 72.7 | | |
| | SHC | 64.1 | 64.7 | 53.9 | 34.4 | 60.9 | 57.5 | 48.3 | 32.5 | 55.7 | 50.4 | 42.9 | 30.3 | | |
| | LDB | 56.45 | 56.36 | 60.42 | 67.53 | 52.08 | 53.76 | 58.09 | 65.30 | 45.91 | 49.38 | 54.05 | 61.76 | | |
| | LWB | 46.99 | 52.91 | 58.10 | 66.82 | 44.91 | 50.90 | 56.21 | 64.87 | 41.85 | 47.48 | 52.80 | 61.64 | | |
| | | KW | 4.21 | 4.29 | 4.27 | 4.19 | 4.32 | 4.30 | 4.26 | 4.17 | 4.45 | 4.35 | 4.33 | 4.20 | |

LEGEND

- BF** — Bypass Factor
- EDB** — Entering Dry Bulb (F)
- EWB** — Entering Wet Bulb (F)
- LDB** — Leaving Dry Bulb (F)
- LWB** — Leaving Wet Bulb (F)
- SHC** — Sensible Capacity (1000 Btu/hr)
- TC** — Total Capacity (1000 Btu/hr)
- kW** — Compressor Motor Power Input (kilowatts)

Performance data (cont)



EVAPORATOR FAN PERFORMANCE

50XCW06 (5 Tons)

| CFM | ESP (in. wg) | | | | | | | | | | | | | | | | | | | |
|------|--------------|------|------|------|------|------|------|------|------|------|------|------|------|------|------|------|------|------|------|------|
| | 0.00 | | 0.10 | | 0.20 | | 0.30 | | 0.40 | | 0.50 | | 0.60 | | 0.70 | | 0.80 | | 0.90 | |
| | Rpm | Bhp | Rpm | Bhp | Rpm | Bhp | Rpm | Bhp | Rpm | Bhp | Rpm | Bhp | Rpm | Bhp | Rpm | Bhp | Rpm | Bhp | Rpm | Bhp |
| 1500 | 594 | 0.23 | 594 | 0.23 | 594 | 0.23 | 612 | 0.24 | 670 | 0.29 | 727 | 0.34 | 785 | 0.40 | 842 | 0.46 | 897 | 0.53 | 950 | 0.60 |
| 1600 | 588 | 0.24 | 588 | 0.24 | 588 | 0.24 | 630 | 0.28 | 684 | 0.32 | 738 | 0.37 | 793 | 0.43 | 847 | 0.49 | 900 | 0.56 | 952 | 0.64 |
| 1700 | 582 | 0.26 | 582 | 0.26 | 596 | 0.27 | 650 | 0.31 | 701 | 0.36 | 752 | 0.41 | 803 | 0.47 | 854 | 0.53 | 905 | 0.60 | 955 | 0.67 |
| 1800 | 576 | 0.28 | 576 | 0.28 | 618 | 0.31 | 670 | 0.36 | 719 | 0.40 | 767 | 0.45 | 815 | 0.51 | 863 | 0.57 | 911 | 0.64 | 959 | 0.71 |
| 1900 | 570 | 0.29 | 586 | 0.31 | 641 | 0.35 | 691 | 0.40 | 738 | 0.45 | 784 | 0.50 | 829 | 0.56 | 875 | 0.62 | 920 | 0.69 | 966 | 0.76 |
| 2000 | 564 | 0.31 | 612 | 0.35 | 664 | 0.40 | 712 | 0.45 | 757 | 0.50 | 801 | 0.56 | 845 | 0.61 | 888 | 0.67 | 931 | 0.74 | 975 | 0.81 |
| 2100 | 593 | 0.36 | 637 | 0.40 | 687 | 0.46 | 734 | 0.51 | 778 | 0.56 | 820 | 0.61 | 862 | 0.67 | 903 | 0.73 | 944 | 0.80 | 985 | 0.87 |
| 2200 | 621 | 0.42 | 663 | 0.46 | 710 | 0.51 | 756 | 0.57 | 799 | 0.62 | 840 | 0.68 | 879 | 0.74 | 919 | 0.80 | 958 | 0.86 | 997 | 0.93 |
| 2300 | 649 | 0.48 | 689 | 0.52 | 734 | 0.58 | 779 | 0.63 | 820 | 0.69 | 860 | 0.75 | 898 | 0.81 | 936 | 0.87 | 974 | 0.93 | 1011 | 1.00 |
| 2400 | 677 | 0.54 | 715 | 0.59 | 759 | 0.64 | 801 | 0.70 | 842 | 0.76 | 880 | 0.82 | 918 | 0.88 | 954 | 0.95 | 990 | 1.01 | 1026 | 1.08 |
| 2500 | 705 | 0.61 | 742 | 0.66 | 783 | 0.72 | 824 | 0.78 | 864 | 0.84 | 902 | 0.90 | 938 | 0.97 | 973 | 1.03 | 1008 | 1.10 | 1043 | 1.17 |

50XCW06 (5 Tons) (cont)

| CFM | ESP (in. wg) | | | | | | | | | | | | | | | | | | | |
|------|--------------|------|------|------|------|------|------|------|------|------|------|------|------|------|------|------|------|------|------|------|
| | 1.00 | | 1.10 | | 1.20 | | 1.30 | | 1.40 | | 1.50 | | 1.60 | | 1.70 | | 1.80 | | 1.90 | |
| | Rpm | Bhp | Rpm | Bhp | Rpm | Bhp | Rpm | Bhp | Rpm | Bhp | Rpm | Bhp | Rpm | Bhp | Rpm | Bhp | Rpm | Bhp | Rpm | Bhp |
| 1500 | 1000 | 0.68 | 1047 | 0.76 | 1092 | 0.84 | 1134 | 0.93 | 1174 | 1.01 | 1213 | 1.10 | 1249 | 1.19 | 1284 | 1.28 | 1318 | 1.36 | 1351 | 1.46 |
| 1600 | 1001 | 0.71 | 1049 | 0.80 | 1094 | 0.88 | 1137 | 0.97 | 1178 | 1.06 | 1218 | 1.14 | 1255 | 1.24 | 1291 | 1.33 | 1326 | 1.42 | 1359 | 1.52 |
| 1700 | 1004 | 0.75 | 1051 | 0.83 | 1096 | 0.92 | 1139 | 1.01 | 1181 | 1.10 | 1221 | 1.19 | 1259 | 1.28 | 1296 | 1.38 | 1331 | 1.48 | 1365 | 1.57 |
| 1800 | 1007 | 0.79 | 1053 | 0.87 | 1098 | 0.96 | 1141 | 1.05 | 1183 | 1.14 | 1224 | 1.24 | 1262 | 1.33 | 1300 | 1.43 | — | — | — | — |
| 1900 | 1011 | 0.83 | 1056 | 0.92 | 1100 | 1.00 | 1143 | 1.09 | 1185 | 1.19 | 1225 | 1.28 | 1264 | 1.38 | 1302 | 1.48 | — | — | — | — |
| 2000 | 1018 | 0.89 | 1061 | 0.97 | 1104 | 1.05 | 1146 | 1.14 | 1187 | 1.24 | 1227 | 1.33 | 1266 | 1.43 | — | — | — | — | — | — |
| 2100 | 1027 | 0.94 | 1068 | 1.02 | 1109 | 1.11 | 1150 | 1.20 | 1190 | 1.29 | 1230 | 1.39 | 1268 | 1.49 | — | — | — | — | — | — |
| 2200 | 1037 | 1.01 | 1076 | 1.09 | 1116 | 1.17 | 1155 | 1.26 | 1194 | 1.35 | 1233 | 1.45 | — | — | — | — | — | — | — | — |
| 2300 | 1049 | 1.08 | 1087 | 1.16 | 1124 | 1.24 | 1162 | 1.33 | 1200 | 1.42 | — | — | — | — | — | — | — | — | — | — |
| 2400 | 1063 | 1.16 | 1099 | 1.23 | 1135 | 1.32 | 1171 | 1.40 | 1207 | 1.49 | — | — | — | — | — | — | — | — | — | — |
| 2500 | 1077 | 1.24 | 1112 | 1.32 | 1147 | 1.40 | 1181 | 1.48 | 1216 | 1.57 | — | — | — | — | — | — | — | — | — | — |

LEGEND

Bhp — Brake Horsepower
ESP — External Static Pressure

NOTES:

- Units are available with several motor hp options. Refer to Physical Data table.
- Static pressure losses for any options or accessories must be applied to external static pressure before entering the fan performance table.
- Interpolation is permitted; extrapolation is not.
- Fan performance is based on 1 in. standard throwaway filter, unit casing, and dry DX (direct expansion) coil losses at sea level.



EVAPORATOR FAN PERFORMANCE (cont)

| 50XCW08 (7½ Tons) | | | | | | | | | | | | | | | | | | | | |
|-------------------|--------------|------|------|------|------|------|------|------|------|------|------|------|------|------|------|------|------|------|------|------|
| CFM | ESP (in. wg) | | | | | | | | | | | | | | | | | | | |
| | 0.00 | | 0.10 | | 0.20 | | 0.30 | | 0.40 | | 0.50 | | 0.60 | | 0.70 | | 0.80 | | 0.90 | |
| | Rpm | Bhp | Rpm | Bhp | Rpm | Bhp | Rpm | Bhp | Rpm | Bhp | Rpm | Bhp | Rpm | Bhp | Rpm | Bhp | Rpm | Bhp | Rpm | Bhp |
| 2200 | 594 | 0.26 | 594 | 0.26 | 594 | 0.26 | 644 | 0.31 | 707 | 0.38 | 766 | 0.45 | 820 | 0.53 | 871 | 0.62 | 918 | 0.70 | 963 | 0.79 |
| 2400 | 588 | 0.28 | 588 | 0.28 | 602 | 0.29 | 667 | 0.36 | 728 | 0.43 | 785 | 0.51 | 838 | 0.59 | 888 | 0.68 | 935 | 0.77 | 979 | 0.86 |
| 2600 | 582 | 0.29 | 582 | 0.29 | 630 | 0.34 | 692 | 0.42 | 750 | 0.49 | 805 | 0.58 | 857 | 0.66 | 906 | 0.75 | 952 | 0.84 | 996 | 0.94 |
| 2800 | 576 | 0.31 | 597 | 0.33 | 659 | 0.41 | 718 | 0.48 | 774 | 0.56 | 827 | 0.65 | 877 | 0.74 | 925 | 0.83 | 970 | 0.93 | 1013 | 1.03 |
| 3000 | 570 | 0.33 | 631 | 0.40 | 690 | 0.48 | 746 | 0.55 | 799 | 0.64 | 850 | 0.73 | 898 | 0.82 | 945 | 0.92 | 989 | 1.02 | 1032 | 1.12 |
| 3200 | 606 | 0.40 | 665 | 0.48 | 721 | 0.55 | 774 | 0.64 | 825 | 0.73 | 874 | 0.82 | 921 | 0.91 | 966 | 1.01 | 1009 | 1.12 | 1051 | 1.22 |
| 3400 | 644 | 0.48 | 699 | 0.56 | 752 | 0.64 | 803 | 0.73 | 852 | 0.82 | 899 | 0.92 | 944 | 1.02 | 988 | 1.12 | 1030 | 1.23 | 1071 | 1.34 |
| 3600 | 681 | 0.57 | 734 | 0.66 | 785 | 0.74 | 833 | 0.83 | 880 | 0.93 | 925 | 1.03 | 969 | 1.13 | 1011 | 1.24 | 1052 | 1.35 | 1092 | 1.46 |
| 3800 | 719 | 0.67 | 770 | 0.76 | 818 | 0.85 | 864 | 0.95 | 909 | 1.04 | 952 | 1.15 | 995 | 1.25 | 1035 | 1.36 | 1075 | 1.48 | 1114 | 1.59 |

| 50XCW08 (7½ Tons) (cont) | | | | | | | | | | | | | | | | | | | | |
|--------------------------|--------------|------|------|------|------|------|------|------|------|------|------|------|------|------|------|------|------|------|------|------|
| CFM | ESP (in. wg) | | | | | | | | | | | | | | | | | | | |
| | 1.00 | | 1.10 | | 1.20 | | 1.30 | | 1.40 | | 1.50 | | 1.60 | | 1.70 | | 1.80 | | 1.90 | |
| | Rpm | Bhp | Rpm | Bhp | Rpm | Bhp | Rpm | Bhp | Rpm | Bhp | Rpm | Bhp | Rpm | Bhp | Rpm | Bhp | Rpm | Bhp | Rpm | Bhp |
| 2200 | 1006 | 0.88 | 1047 | 0.97 | 1085 | 1.07 | 1122 | 1.17 | 1158 | 1.27 | 1193 | 1.37 | 1226 | 1.47 | 1258 | 1.58 | — | — | — | — |
| 2400 | 1022 | 0.96 | 1062 | 1.05 | 1101 | 1.15 | 1138 | 1.26 | 1174 | 1.36 | 1209 | 1.46 | 1242 | 1.57 | 1274 | 1.68 | 1306 | 1.79 | 1336 | 1.90 |
| 2600 | 1038 | 1.04 | 1078 | 1.14 | 1117 | 1.24 | 1154 | 1.35 | 1190 | 1.46 | 1225 | 1.57 | 1258 | 1.68 | 1290 | 1.79 | 1322 | 1.91 | 1352 | 2.03 |
| 2800 | 1055 | 1.13 | 1095 | 1.23 | 1133 | 1.34 | 1170 | 1.45 | 1206 | 1.56 | 1240 | 1.68 | 1274 | 1.79 | 1306 | 1.91 | 1338 | 2.03 | 1368 | 2.15 |
| 3000 | 1073 | 1.23 | 1112 | 1.34 | 1150 | 1.45 | 1187 | 1.56 | 1222 | 1.68 | 1256 | 1.79 | 1290 | 1.91 | 1322 | 2.04 | 1353 | 2.16 | 1384 | 2.29 |
| 3200 | 1091 | 1.33 | 1130 | 1.45 | 1167 | 1.56 | 1204 | 1.68 | 1239 | 1.80 | 1273 | 1.92 | 1306 | 2.04 | 1338 | 2.17 | 1369 | 2.30 | 1400 | 2.43 |
| 3400 | 1110 | 1.45 | 1148 | 1.57 | 1185 | 1.68 | 1221 | 1.81 | 1256 | 1.93 | 1290 | 2.05 | 1322 | 2.18 | 1354 | 2.31 | 1385 | 2.44 | 1416 | 2.58 |
| 3600 | 1131 | 1.58 | 1168 | 1.69 | 1204 | 1.82 | 1239 | 1.94 | 1274 | 2.07 | 1307 | 2.20 | 1340 | 2.33 | 1371 | 2.46 | 1402 | 2.60 | 1432 | 2.74 |
| 3800 | 1152 | 1.71 | 1188 | 1.84 | 1224 | 1.96 | 1258 | 2.09 | 1292 | 2.22 | 1325 | 2.35 | 1357 | 2.49 | 1389 | 2.62 | 1419 | 2.76 | 1449 | 2.90 |

| 50XCW08 (7½ Tons) (cont) | | | | | | | | | | |
|--------------------------|--------------|------|------|------|------|------|------|------|------|------|
| CFM | ESP (in. wg) | | | | | | | | | |
| | 2.00 | | 2.10 | | 2.20 | | 2.30 | | 2.40 | |
| | Rpm | Bhp | Rpm | Bhp | Rpm | Bhp | Rpm | Bhp | Rpm | Bhp |
| 2200 | — | — | — | — | — | — | — | — | — | — |
| 2400 | 1366 | 2.02 | 1395 | 2.13 | — | — | — | — | — | — |
| 2600 | 1382 | 2.14 | 1411 | 2.26 | 1439 | 2.39 | 1467 | 2.51 | 1494 | 2.63 |
| 2800 | 1398 | 2.27 | 1427 | 2.40 | 1455 | 2.52 | 1483 | 2.65 | 1510 | 2.78 |
| 3000 | 1414 | 2.41 | 1443 | 2.54 | 1471 | 2.67 | 1499 | 2.80 | 1526 | 2.94 |
| 3200 | 1429 | 2.56 | 1459 | 2.69 | 1487 | 2.82 | 1515 | 2.96 | — | — |
| 3400 | 1445 | 2.71 | 1474 | 2.85 | 1503 | 2.99 | — | — | — | — |
| 3600 | 1462 | 2.87 | — | — | — | — | — | — | — | — |
| 3800 | — | — | — | — | — | — | — | — | — | — |

LEGEND

Bhp — Brake Horsepower
ESP — External Static Pressure

NOTES:

- Units are available with several motor hp options. Refer to Physical Data table.
- Static pressure losses for any options or accessories must be applied to external static pressure before entering the fan performance table.

- Interpolation is permitted; extrapolation is not.
- Fan performance is based on 1 in. standard throwaway filter, unit casing, and dry DX (direct expansion) coil losses at sea level.

Performance data (cont)



EVAPORATOR FAN PERFORMANCE (cont)

| 50XCW12 (10 Tons) | | | | | | | | | | | | | | | | | | | | |
|-------------------|--------------|------|------|------|------|------|------|------|------|------|------|------|------|------|------|------|------|------|------|------|
| CFM | ESP (in. wg) | | | | | | | | | | | | | | | | | | | |
| | 0.00 | | 0.10 | | 0.20 | | 0.30 | | 0.40 | | 0.50 | | 0.60 | | 0.70 | | 0.80 | | 0.90 | |
| | Rpm | Bhp | Rpm | Bhp | Rpm | Bhp | Rpm | Bhp | Rpm | Bhp | Rpm | Bhp | Rpm | Bhp | Rpm | Bhp | Rpm | Bhp | Rpm | Bhp |
| 3000 | 410 | 0.32 | 475 | 0.41 | 536 | 0.51 | 592 | 0.62 | 645 | 0.74 | 696 | 0.86 | 743 | 0.99 | 789 | 1.12 | 832 | 1.26 | 874 | 1.40 |
| 3200 | 437 | 0.38 | 498 | 0.48 | 556 | 0.59 | 610 | 0.70 | 661 | 0.83 | 710 | 0.95 | 756 | 1.08 | 800 | 1.22 | 843 | 1.36 | 884 | 1.51 |
| 3400 | 464 | 0.46 | 522 | 0.57 | 577 | 0.68 | 629 | 0.80 | 678 | 0.92 | 725 | 1.05 | 770 | 1.19 | 813 | 1.33 | 854 | 1.48 | 894 | 1.63 |
| 3600 | 492 | 0.55 | 547 | 0.66 | 599 | 0.77 | 649 | 0.90 | 696 | 1.03 | 741 | 1.17 | 785 | 1.31 | 827 | 1.45 | 867 | 1.60 | 906 | 1.76 |
| 3800 | 519 | 0.64 | 571 | 0.76 | 621 | 0.88 | 669 | 1.01 | 714 | 1.15 | 758 | 1.29 | 800 | 1.43 | 841 | 1.59 | 880 | 1.74 | 918 | 1.90 |
| 4000 | 546 | 0.75 | 596 | 0.87 | 644 | 1.00 | 689 | 1.14 | 733 | 1.28 | 776 | 1.42 | 817 | 1.57 | 856 | 1.73 | 894 | 1.89 | 932 | 2.05 |
| 4200 | 574 | 0.87 | 621 | 0.99 | 667 | 1.13 | 711 | 1.27 | 753 | 1.42 | 794 | 1.57 | 834 | 1.72 | 872 | 1.88 | 909 | 2.05 | 946 | 2.22 |
| 4400 | 601 | 1.00 | 646 | 1.13 | 690 | 1.27 | 732 | 1.42 | 773 | 1.57 | 813 | 1.72 | 852 | 1.88 | 889 | 2.05 | 925 | 2.22 | 960 | 2.39 |
| 4600 | 628 | 1.14 | 672 | 1.28 | 714 | 1.42 | 755 | 1.58 | 794 | 1.73 | 833 | 1.89 | 870 | 2.06 | 906 | 2.23 | 942 | 2.40 | 976 | 2.58 |
| 4800 | 655 | 1.29 | 697 | 1.44 | 738 | 1.59 | 777 | 1.75 | 815 | 1.91 | 853 | 2.08 | 889 | 2.25 | 924 | 2.42 | 958 | 2.60 | 992 | 2.78 |
| 5000 | 683 | 1.46 | 723 | 1.61 | 762 | 1.77 | 800 | 1.93 | 837 | 2.10 | 873 | 2.27 | 908 | 2.45 | 943 | 2.63 | 976 | 2.81 | 1009 | 3.00 |

| 50XCA12 (10 Tons) (cont) | | | | | | | | | | | | | | | | | | | | |
|--------------------------|--------------|------|------|------|------|------|------|------|------|------|------|------|------|------|------|------|------|------|------|------|
| CFM | ESP (in. wg) | | | | | | | | | | | | | | | | | | | |
| | 1.00 | | 1.10 | | 1.20 | | 1.30 | | 1.40 | | 1.50 | | 1.60 | | 1.70 | | 1.80 | | 1.90 | |
| | Rpm | Bhp | Rpm | Bhp | Rpm | Bhp | Rpm | Bhp | Rpm | Bhp | Rpm | Bhp | Rpm | Bhp | Rpm | Bhp | Rpm | Bhp | Rpm | Bhp |
| 3000 | 914 | 1.55 | — | — | — | — | — | — | — | — | — | — | — | — | — | — | — | — | — | — |
| 3200 | 923 | 1.66 | 961 | 1.82 | — | — | — | — | — | — | — | — | — | — | — | — | — | — | — | — |
| 3400 | 933 | 1.79 | 970 | 1.95 | 1006 | 2.11 | — | — | — | — | — | — | — | — | — | — | — | — | — | — |
| 3600 | 943 | 1.92 | 980 | 2.09 | 1015 | 2.25 | 1050 | 2.43 | 1084 | 2.61 | — | — | — | — | — | — | — | — | — | — |
| 3800 | 955 | 2.07 | 991 | 2.24 | 1026 | 2.41 | 1060 | 2.59 | 1093 | 2.77 | 1125 | 2.95 | 1156 | 3.14 | — | — | — | — | — | — |
| 4000 | 968 | 2.22 | 1003 | 2.40 | 1037 | 2.57 | 1070 | 2.75 | 1102 | 2.94 | 1134 | 3.13 | 1165 | 3.32 | 1195 | 3.52 | — | — | — | — |
| 4200 | 981 | 2.39 | 1015 | 2.57 | 1049 | 2.75 | 1081 | 2.94 | 1113 | 3.12 | 1144 | 3.32 | 1175 | 3.51 | 1205 | 3.71 | 1234 | 3.92 | 1263 | 4.13 |
| 4400 | 995 | 2.57 | 1028 | 2.75 | 1061 | 2.94 | 1093 | 3.13 | 1124 | 3.32 | 1155 | 3.52 | 1185 | 3.72 | 1214 | 3.92 | 1243 | 4.13 | 1272 | 4.34 |
| 4600 | 1010 | 2.76 | 1042 | 2.95 | 1074 | 3.14 | 1106 | 3.34 | 1136 | 3.53 | 1166 | 3.74 | 1196 | 3.94 | 1225 | 4.15 | 1253 | 4.36 | 1281 | 4.58 |
| 4800 | 1025 | 2.97 | 1057 | 3.16 | 1088 | 3.36 | 1119 | 3.56 | 1149 | 3.76 | 1179 | 3.96 | 1208 | 4.17 | 1236 | 4.39 | 1264 | 4.60 | 1292 | 4.82 |
| 5000 | 1041 | 3.19 | 1072 | 3.39 | 1103 | 3.59 | 1133 | 3.79 | 1163 | 4.00 | 1192 | 4.21 | 1220 | 4.42 | 1248 | 4.64 | 1276 | 4.86 | 1303 | 5.08 |

LEGEND

Bhp — Brake Horsepower
ESP — External Static Pressure

NOTES:

- Units are available with several motor hp options. Refer to Physical Data table.
- Static pressure losses for any options or accessories must be applied to external static pressure before entering the fan performance table.
- Interpolation is permitted; extrapolation is not.
- Fan performance is based on 1 in. standard throwaway filter, unit casing, and dry DX (direct expansion) coil losses at sea level.



EVAPORATOR FAN PERFORMANCE (cont)

50XCW14 (12 Tons)

| CFM | ESP (in. wg) | | | | | | | | | | | | | | | | | | | |
|------|--------------|------|------|------|------|------|------|------|------|------|------|------|------|------|------|------|------|------|------|------|
| | 0.00 | | 0.10 | | 0.20 | | 0.30 | | 0.40 | | 0.50 | | 0.60 | | 0.70 | | 0.80 | | 0.90 | |
| | Rpm | Bhp | Rpm | Bhp | Rpm | Bhp | Rpm | Bhp | Rpm | Bhp | Rpm | Bhp | Rpm | Bhp | Rpm | Bhp | Rpm | Bhp | Rpm | Bhp |
| 3500 | 594 | 0.62 | 594 | 0.62 | 645 | 0.71 | 694 | 0.80 | 739 | 0.88 | 782 | 0.97 | 823 | 1.06 | 862 | 1.15 | 900 | 1.23 | 936 | 1.32 |
| 3700 | 588 | 0.66 | 622 | 0.72 | 671 | 0.82 | 718 | 0.91 | 761 | 1.00 | 803 | 1.09 | 843 | 1.18 | 881 | 1.28 | 918 | 1.37 | 953 | 1.46 |
| 3900 | 600 | 0.74 | 650 | 0.84 | 697 | 0.93 | 742 | 1.03 | 784 | 1.13 | 825 | 1.22 | 863 | 1.32 | 901 | 1.42 | 937 | 1.52 | 971 | 1.61 |
| 4100 | 630 | 0.86 | 678 | 0.96 | 724 | 1.06 | 767 | 1.16 | 808 | 1.27 | 847 | 1.37 | 885 | 1.47 | 921 | 1.57 | 956 | 1.68 | 990 | 1.78 |
| 4300 | 661 | 0.99 | 707 | 1.10 | 751 | 1.20 | 792 | 1.31 | 832 | 1.42 | 870 | 1.53 | 907 | 1.63 | 942 | 1.74 | 976 | 1.85 | 1009 | 1.95 |
| 4500 | 692 | 1.14 | 736 | 1.25 | 778 | 1.36 | 818 | 1.47 | 856 | 1.58 | 893 | 1.69 | 929 | 1.81 | 963 | 1.92 | 997 | 2.03 | 1029 | 2.14 |
| 4700 | 723 | 1.29 | 765 | 1.41 | 805 | 1.53 | 844 | 1.64 | 881 | 1.76 | 917 | 1.88 | 952 | 1.99 | 985 | 2.11 | 1018 | 2.23 | 1050 | 2.35 |
| 4900 | 753 | 1.47 | 794 | 1.59 | 833 | 1.71 | 870 | 1.83 | 906 | 1.95 | 941 | 2.08 | 975 | 2.20 | 1008 | 2.32 | 1040 | 2.44 | 1071 | 2.56 |
| 5100 | 784 | 1.65 | 823 | 1.78 | 861 | 1.91 | 897 | 2.03 | 932 | 2.16 | 966 | 2.29 | 999 | 2.41 | 1031 | 2.54 | 1062 | 2.67 | 1092 | 2.79 |
| 5300 | 815 | 1.86 | 853 | 1.99 | 889 | 2.12 | 924 | 2.25 | 958 | 2.38 | 991 | 2.51 | 1023 | 2.65 | 1054 | 2.78 | 1084 | 2.91 | 1114 | 3.04 |
| 5500 | 846 | 2.07 | 882 | 2.21 | 917 | 2.35 | 951 | 2.48 | 984 | 2.62 | 1016 | 2.76 | 1047 | 2.89 | 1078 | 3.03 | 1107 | 3.17 | 1136 | 3.30 |
| 5700 | 876 | 2.31 | 911 | 2.45 | 945 | 2.59 | 978 | 2.73 | 1011 | 2.88 | 1042 | 3.02 | 1072 | 3.16 | 1102 | 3.30 | 1131 | 3.44 | 1159 | 3.58 |
| 5900 | 907 | 2.56 | 941 | 2.71 | 974 | 2.85 | 1006 | 3.00 | 1037 | 3.15 | 1068 | 3.29 | 1097 | 3.44 | 1126 | 3.59 | 1155 | 3.73 | 1182 | 3.88 |
| 6100 | 938 | 2.83 | 971 | 2.98 | 1003 | 3.13 | 1034 | 3.28 | 1064 | 3.44 | 1094 | 3.59 | 1123 | 3.74 | 1151 | 3.89 | 1179 | 4.04 | 1206 | 4.19 |

50XCW14 (12 Tons) (cont)

| CFM | ESP (in. wg) | | | | | | | | | | | | | | | | | | | |
|------|--------------|------|------|------|------|------|------|------|------|------|------|------|------|------|------|------|------|------|------|------|
| | 1.00 | | 1.10 | | 1.20 | | 1.30 | | 1.40 | | 1.50 | | 1.60 | | 1.70 | | 1.80 | | 1.90 | |
| | Rpm | Bhp | Rpm | Bhp | Rpm | Bhp | Rpm | Bhp | Rpm | Bhp | Rpm | Bhp | Rpm | Bhp | Rpm | Bhp | Rpm | Bhp | Rpm | Bhp |
| 3500 | 971 | 1.41 | 1005 | 1.50 | 1038 | 1.59 | — | — | — | — | — | — | — | — | — | — | — | — | — | — |
| 3700 | 987 | 1.56 | 1021 | 1.65 | 1053 | 1.75 | 1084 | 1.84 | 1115 | 1.94 | — | — | — | — | — | — | — | — | — | — |
| 3900 | 1005 | 1.71 | 1037 | 1.81 | 1069 | 1.91 | 1100 | 2.01 | 1130 | 2.11 | 1159 | 2.21 | 1187 | 2.31 | — | — | — | — | — | — |
| 4100 | 1023 | 1.88 | 1055 | 1.98 | 1086 | 2.09 | 1116 | 2.19 | 1145 | 2.30 | 1174 | 2.40 | 1202 | 2.51 | 1230 | 2.62 | — | — | — | — |
| 4300 | 1041 | 2.06 | 1073 | 2.17 | 1103 | 2.28 | 1133 | 2.39 | 1162 | 2.50 | 1190 | 2.61 | 1218 | 2.72 | 1245 | 2.83 | 1272 | 2.94 | 1298 | 3.05 |
| 4500 | 1061 | 2.26 | 1091 | 2.37 | 1121 | 2.48 | 1150 | 2.60 | 1179 | 2.71 | 1207 | 2.82 | 1234 | 2.94 | 1261 | 3.05 | 1287 | 3.17 | 1313 | 3.29 |
| 4700 | 1080 | 2.46 | 1110 | 2.58 | 1140 | 2.70 | 1168 | 2.82 | 1196 | 2.94 | 1224 | 3.06 | 1251 | 3.17 | 1277 | 3.29 | 1303 | 3.41 | 1328 | 3.53 |
| 4900 | 1101 | 2.68 | 1130 | 2.81 | 1159 | 2.93 | 1187 | 3.05 | 1215 | 3.18 | 1242 | 3.30 | 1268 | 3.42 | 1294 | 3.55 | 1319 | 3.67 | 1344 | 3.80 |
| 5100 | 1122 | 2.92 | 1150 | 3.05 | 1179 | 3.18 | 1206 | 3.30 | 1233 | 3.43 | 1260 | 3.56 | 1286 | 3.69 | 1311 | 3.82 | 1336 | 3.95 | 1361 | 4.08 |
| 5300 | 1143 | 3.17 | 1171 | 3.30 | 1199 | 3.44 | 1226 | 3.57 | 1253 | 3.70 | 1279 | 3.84 | 1304 | 3.97 | 1329 | 4.10 | 1354 | 4.24 | 1378 | 4.37 |
| 5500 | 1165 | 3.44 | 1192 | 3.58 | 1220 | 3.71 | 1246 | 3.85 | 1272 | 3.99 | 1298 | 4.13 | 1323 | 4.26 | 1348 | 4.40 | 1372 | 4.54 | 1396 | 4.68 |
| 5700 | 1187 | 3.72 | 1214 | 3.87 | 1241 | 4.01 | 1267 | 4.15 | 1292 | 4.29 | 1318 | 4.44 | 1342 | 4.58 | 1367 | 4.72 | 1391 | 4.86 | — | — |
| 5900 | 1209 | 4.03 | 1236 | 4.17 | 1262 | 4.32 | 1288 | 4.47 | 1313 | 4.61 | 1338 | 4.76 | 1362 | 4.91 | — | — | — | — | — | — |
| 6100 | 1232 | 4.34 | 1258 | 4.50 | 1284 | 4.65 | 1309 | 4.80 | 1334 | 4.95 | — | — | — | — | — | — | — | — | — | — |

LEGEND

Bhp — Brake Horsepower
ESP — External Static Pressure

NOTES:

- Units are available with several motor hp options. Refer to Physical Data table.
- Static pressure losses for any options or accessories must be applied to external static pressure before entering the fan performance table.
- Interpolation is permitted; extrapolation is not.
- Fan performance is based on 1 in. standard throwaway filter, unit casing, and dry DX (direct expansion) coil losses at sea level.

Performance data (cont)



EVAPORATOR FAN PERFORMANCE (cont)

| 50XCW16 (15 Tons) | | | | | | | | | | | | | | | | | | | | |
|-------------------|--------------|------|------|------|------|------|------|------|------|------|------|------|------|------|------|------|------|------|------|------|
| CFM | ESP (in. wg) | | | | | | | | | | | | | | | | | | | |
| | 0.00 | | 0.10 | | 0.20 | | 0.30 | | 0.40 | | 0.50 | | 0.60 | | 0.70 | | 0.80 | | 0.90 | |
| | Rpm | Bhp | Rpm | Bhp | Rpm | Bhp | Rpm | Bhp | Rpm | Bhp | Rpm | Bhp | Rpm | Bhp | Rpm | Bhp | Rpm | Bhp | Rpm | Bhp |
| 4500 | 594 | 0.50 | 594 | 0.50 | 603 | 0.51 | 656 | 0.59 | 706 | 0.67 | 753 | 0.75 | 798 | 0.82 | 840 | 0.90 | 880 | 0.98 | — | — |
| 4750 | 588 | 0.53 | 588 | 0.53 | 624 | 0.58 | 676 | 0.67 | 724 | 0.75 | 770 | 0.83 | 813 | 0.91 | 855 | 1.00 | 894 | 1.08 | 933 | 1.16 |
| 5000 | 582 | 0.56 | 592 | 0.58 | 646 | 0.66 | 696 | 0.75 | 743 | 0.83 | 787 | 0.92 | 830 | 1.01 | 870 | 1.10 | 909 | 1.18 | 947 | 1.27 |
| 5250 | 576 | 0.59 | 616 | 0.66 | 668 | 0.75 | 716 | 0.84 | 762 | 0.93 | 805 | 1.02 | 847 | 1.11 | 886 | 1.20 | 924 | 1.29 | 961 | 1.39 |
| 5500 | 587 | 0.65 | 641 | 0.75 | 690 | 0.84 | 737 | 0.94 | 782 | 1.03 | 824 | 1.13 | 864 | 1.22 | 903 | 1.32 | 940 | 1.41 | 976 | 1.51 |
| 5750 | 614 | 0.75 | 665 | 0.85 | 713 | 0.94 | 759 | 1.04 | 802 | 1.14 | 843 | 1.24 | 882 | 1.34 | 920 | 1.44 | 957 | 1.54 | 992 | 1.64 |
| 6000 | 641 | 0.85 | 690 | 0.95 | 736 | 1.05 | 780 | 1.16 | 822 | 1.26 | 862 | 1.36 | 901 | 1.47 | 938 | 1.57 | 974 | 1.67 | 1008 | 1.78 |
| 6250 | 667 | 0.96 | 715 | 1.07 | 760 | 1.17 | 802 | 1.28 | 843 | 1.39 | 882 | 1.49 | 920 | 1.60 | 956 | 1.71 | 991 | 1.82 | 1025 | 1.93 |
| 6500 | 694 | 1.08 | 740 | 1.19 | 783 | 1.30 | 824 | 1.41 | 864 | 1.52 | 902 | 1.64 | 939 | 1.75 | 974 | 1.86 | 1009 | 1.97 | 1042 | 2.08 |
| 6750 | 721 | 1.21 | 765 | 1.32 | 807 | 1.44 | 847 | 1.56 | 885 | 1.67 | 923 | 1.79 | 958 | 1.90 | 993 | 2.02 | 1027 | 2.13 | 1059 | 2.25 |
| 7000 | 747 | 1.35 | 790 | 1.47 | 831 | 1.59 | 870 | 1.71 | 907 | 1.83 | 943 | 1.95 | 978 | 2.07 | 1012 | 2.19 | 1045 | 2.31 | 1077 | 2.43 |
| 7250 | 774 | 1.50 | 815 | 1.62 | 855 | 1.75 | 893 | 1.87 | 929 | 1.99 | 965 | 2.12 | 999 | 2.24 | 1032 | 2.37 | 1064 | 2.49 | 1096 | 2.62 |
| 7500 | 801 | 1.66 | 841 | 1.79 | 879 | 1.92 | 916 | 2.04 | 951 | 2.17 | 986 | 2.30 | 1019 | 2.43 | 1052 | 2.56 | 1084 | 2.69 | 1114 | 2.82 |

| 50XCW16 (15 Tons) (cont) | | | | | | | | | | | | | | | | | | | | |
|--------------------------|--------------|------|------|------|------|------|------|------|------|------|------|------|------|------|------|------|------|------|------|------|
| CFM | ESP (in. wg) | | | | | | | | | | | | | | | | | | | |
| | 1.00 | | 1.10 | | 1.20 | | 1.30 | | 1.40 | | 1.50 | | 1.60 | | 1.70 | | 1.80 | | 1.90 | |
| | Rpm | Bhp | Rpm | Bhp | Rpm | Bhp | Rpm | Bhp | Rpm | Bhp | Rpm | Bhp | Rpm | Bhp | Rpm | Bhp | Rpm | Bhp | Rpm | Bhp |
| 4500 | — | — | — | — | — | — | — | — | — | — | — | — | — | — | — | — | — | — | — | — |
| 4750 | — | — | — | — | — | — | — | — | — | — | — | — | — | — | — | — | — | — | — | — |
| 5000 | 983 | 1.36 | — | — | — | — | — | — | — | — | — | — | — | — | — | — | — | — | — | — |
| 5250 | 997 | 1.48 | 1031 | 1.57 | 1064 | 1.67 | — | — | — | — | — | — | — | — | — | — | — | — | — | — |
| 5500 | 1011 | 1.61 | 1045 | 1.70 | 1078 | 1.80 | 1109 | 1.90 | — | — | — | — | — | — | — | — | — | — | — | — |
| 5750 | 1026 | 1.74 | 1059 | 1.84 | 1092 | 1.94 | 1123 | 2.05 | 1154 | 2.15 | — | — | — | — | — | — | — | — | — | — |
| 6000 | 1042 | 1.88 | 1074 | 1.99 | 1106 | 2.10 | 1137 | 2.20 | 1167 | 2.31 | 1197 | 2.42 | 1226 | 2.53 | — | — | — | — | — | — |
| 6250 | 1058 | 2.04 | 1090 | 2.15 | 1121 | 2.26 | 1152 | 2.37 | 1181 | 2.48 | 1210 | 2.59 | 1239 | 2.70 | 1267 | 2.81 | — | — | — | — |
| 6500 | 1074 | 2.20 | 1106 | 2.31 | 1136 | 2.43 | 1167 | 2.54 | 1196 | 2.65 | 1225 | 2.77 | 1253 | 2.89 | 1280 | 3.00 | 1307 | 3.12 | — | — |
| 6750 | 1091 | 2.37 | 1122 | 2.49 | 1152 | 2.60 | 1182 | 2.72 | 1211 | 2.84 | 1239 | 2.96 | 1267 | 3.08 | 1294 | 3.20 | 1321 | 3.32 | 1347 | 3.44 |
| 7000 | 1109 | 2.55 | 1139 | 2.67 | 1169 | 2.79 | 1198 | 2.92 | 1226 | 3.04 | 1254 | 3.16 | 1281 | 3.29 | 1308 | 3.41 | 1335 | 3.54 | 1360 | 3.66 |
| 7250 | 1126 | 2.74 | 1156 | 2.87 | 1186 | 2.99 | 1214 | 3.12 | 1242 | 3.25 | 1270 | 3.37 | 1297 | 3.50 | 1323 | 3.63 | 1349 | 3.76 | 1374 | 3.89 |
| 7500 | 1145 | 2.94 | 1174 | 3.07 | 1203 | 3.20 | 1231 | 3.33 | 1258 | 3.47 | 1286 | 3.60 | 1312 | 3.73 | 1338 | 3.86 | 1364 | 3.99 | 1389 | 4.13 |

LEGEND

Bhp — Brake Horsepower
ESP — External Static Pressure

NOTES:

- Units are available with several motor hp options. Refer to Physical Data table.
- Static pressure losses for any options or accessories must be applied to external static pressure before entering the fan performance table.
- Interpolation is permitted; extrapolation is not.
- Fan performance is based on 1 in. standard throwaway filter, unit casing, and dry DX (direct expansion) coil losses at sea level.



EVAPORATOR FAN PERFORMANCE (cont)

50XCW24 (20 Tons)

| CFM | ESP (in. wg) | | | | | | | | | | | | | | | | | | | |
|--------|--------------|------|------|------|------|------|------|------|------|------|------|------|------|------|------|------|------|------|------|------|
| | 0.00 | | 0.10 | | 0.20 | | 0.30 | | 0.40 | | 0.50 | | 0.60 | | 0.70 | | 0.80 | | 0.90 | |
| | Rpm | Bhp | Rpm | Bhp | Rpm | Bhp | Rpm | Bhp | Rpm | Bhp | Rpm | Bhp | Rpm | Bhp | Rpm | Bhp | Rpm | Bhp | Rpm | Bhp |
| 6,000 | 594 | 1.01 | 594 | 1.01 | 645 | 1.17 | 693 | 1.34 | 737 | 1.52 | 781 | 1.70 | 825 | 1.90 | 870 | 2.12 | 917 | 2.36 | 965 | 2.62 |
| 6,300 | 588 | 1.07 | 612 | 1.14 | 667 | 1.32 | 714 | 1.50 | 757 | 1.68 | 799 | 1.87 | 840 | 2.07 | 883 | 2.28 | 926 | 2.52 | 971 | 2.77 |
| 6,600 | 588 | 1.14 | 636 | 1.29 | 689 | 1.48 | 735 | 1.67 | 777 | 1.86 | 817 | 2.05 | 857 | 2.25 | 897 | 2.47 | 938 | 2.70 | 979 | 2.95 |
| 6,900 | 615 | 1.30 | 660 | 1.45 | 711 | 1.65 | 757 | 1.85 | 798 | 2.05 | 837 | 2.25 | 875 | 2.45 | 913 | 2.67 | 951 | 2.90 | 990 | 3.15 |
| 7,200 | 642 | 1.48 | 684 | 1.63 | 734 | 1.84 | 779 | 2.05 | 819 | 2.25 | 857 | 2.46 | 894 | 2.67 | 930 | 2.89 | 966 | 3.13 | 1003 | 3.37 |
| 7,500 | 668 | 1.68 | 708 | 1.83 | 756 | 2.04 | 801 | 2.26 | 840 | 2.47 | 877 | 2.69 | 913 | 2.91 | 948 | 3.13 | 983 | 3.37 | 1018 | 3.61 |
| 7,800 | 695 | 1.88 | 733 | 2.04 | 779 | 2.26 | 823 | 2.49 | 862 | 2.71 | 898 | 2.93 | 933 | 3.16 | 967 | 3.39 | 1000 | 3.63 | 1034 | 3.87 |
| 8,000 | 713 | 2.03 | 750 | 2.19 | 795 | 2.41 | 838 | 2.65 | 876 | 2.88 | 912 | 3.10 | 946 | 3.33 | 979 | 3.57 | 1012 | 3.81 | 1045 | 4.06 |
| 8,300 | 740 | 2.27 | 774 | 2.43 | 818 | 2.66 | 860 | 2.90 | 898 | 3.14 | 934 | 3.38 | 967 | 3.61 | 999 | 3.85 | 1031 | 4.10 | 1062 | 4.35 |
| 8,600 | 766 | 2.53 | 800 | 2.69 | 841 | 2.92 | 882 | 3.17 | 920 | 3.42 | 955 | 3.67 | 988 | 3.91 | 1019 | 4.16 | 1050 | 4.41 | 1081 | 4.67 |
| 8,900 | 793 | 2.80 | 825 | 2.97 | 865 | 3.20 | 905 | 3.46 | 942 | 3.72 | 977 | 3.97 | 1009 | 4.23 | 1040 | 4.48 | 1070 | 4.74 | 1100 | 5.00 |
| 9,200 | 820 | 3.09 | 850 | 3.27 | 888 | 3.50 | 928 | 3.77 | 964 | 4.04 | 998 | 4.30 | 1030 | 4.56 | 1061 | 4.82 | 1090 | 5.09 | 1119 | 5.36 |
| 9,500 | 846 | 3.40 | 876 | 3.58 | 912 | 3.82 | 950 | 4.09 | 987 | 4.37 | 1020 | 4.64 | 1052 | 4.92 | 1082 | 5.19 | 1111 | 5.46 | 1139 | 5.73 |
| 9,800 | 873 | 3.74 | 901 | 3.92 | 936 | 4.16 | 973 | 4.44 | 1009 | 4.72 | 1042 | 5.01 | 1074 | 5.29 | 1103 | 5.57 | 1131 | 5.85 | 1159 | 6.13 |
| 10,000 | 891 | 3.97 | 918 | 4.16 | 952 | 4.40 | 989 | 4.68 | 1024 | 4.97 | 1057 | 5.26 | 1088 | 5.55 | 1117 | 5.83 | 1145 | 6.12 | 1173 | 6.40 |

50XCW24 (20 Tons) (cont)

| CFM | ESP (in. wg) | | | | | | | | | | | | | | | | | | | |
|--------|--------------|------|------|------|------|------|------|------|------|------|------|------|------|------|------|------|------|------|------|------|
| | 1.00 | | 1.10 | | 1.20 | | 1.30 | | 1.40 | | 1.50 | | 1.60 | | 1.70 | | 1.80 | | 1.90 | |
| | Rpm | Bhp | Rpm | Bhp | Rpm | Bhp | Rpm | Bhp | Rpm | Bhp | Rpm | Bhp | Rpm | Bhp | Rpm | Bhp | Rpm | Bhp | Rpm | Bhp |
| 6,000 | 1014 | 2.90 | 1063 | 3.20 | 1112 | 3.53 | 1161 | 3.87 | 1208 | 4.23 | — | — | — | — | — | — | — | — | — | — |
| 6,300 | 1016 | 3.05 | 1063 | 3.35 | 1110 | 3.66 | 1157 | 4.00 | 1204 | 4.36 | 1249 | 4.73 | — | — | — | — | — | — | — | — |
| 6,600 | 1022 | 3.22 | 1066 | 3.51 | 1111 | 3.83 | 1155 | 4.16 | 1200 | 4.50 | 1245 | 4.87 | 1289 | 5.25 | 1332 | 5.65 | — | — | — | — |
| 6,900 | 1030 | 3.42 | 1072 | 3.70 | 1113 | 4.01 | 1156 | 4.33 | 1199 | 4.67 | 1242 | 5.03 | 1285 | 5.41 | 1327 | 5.80 | 1369 | 6.21 | 1409 | 6.63 |
| 7,200 | 1041 | 3.64 | 1080 | 3.92 | 1119 | 4.22 | 1159 | 4.53 | 1200 | 4.87 | 1241 | 5.22 | 1282 | 5.59 | 1323 | 5.98 | 1364 | 6.38 | 1404 | 6.80 |
| 7,500 | 1053 | 3.88 | 1090 | 4.15 | 1127 | 4.45 | 1165 | 4.76 | 1203 | 5.09 | 1242 | 5.43 | 1282 | 5.80 | 1321 | 6.18 | 1361 | 6.58 | 1400 | 6.99 |
| 7,800 | 1068 | 4.14 | 1102 | 4.41 | 1137 | 4.70 | 1173 | 5.01 | 1209 | 5.33 | 1246 | 5.67 | 1284 | 6.03 | 1321 | 6.40 | 1360 | 6.80 | 1397 | 7.20 |
| 8,000 | 1078 | 4.32 | 1111 | 4.60 | 1145 | 4.88 | 1179 | 5.19 | 1214 | 5.51 | 1250 | 5.85 | 1286 | 6.20 | 1323 | 6.57 | 1360 | 6.96 | 1397 | 7.36 |
| 8,300 | 1094 | 4.62 | 1126 | 4.89 | 1158 | 5.18 | 1191 | 5.48 | 1224 | 5.80 | 1258 | 6.13 | 1292 | 6.48 | 1327 | 6.84 | 1362 | 7.22 | 1397 | 7.62 |
| 8,600 | 1111 | 4.93 | 1141 | 5.21 | 1172 | 5.50 | 1203 | 5.80 | 1235 | 6.11 | 1267 | 6.44 | 1300 | 6.78 | 1333 | 7.14 | 1366 | 7.51 | 1400 | 7.90 |
| 8,900 | 1129 | 5.27 | 1158 | 5.55 | 1188 | 5.84 | 1218 | 6.14 | 1248 | 6.45 | 1278 | 6.77 | 1309 | 7.11 | 1341 | 7.47 | 1372 | 7.83 | 1405 | 8.22 |
| 9,200 | 1147 | 5.63 | 1176 | 5.91 | 1204 | 6.20 | 1233 | 6.50 | 1262 | 6.81 | 1291 | 7.14 | 1320 | 7.47 | 1350 | 7.82 | 1381 | 8.19 | 1411 | 8.56 |
| 9,500 | 1167 | 6.01 | 1194 | 6.30 | 1222 | 6.59 | 1249 | 6.89 | 1277 | 7.20 | 1305 | 7.53 | 1333 | 7.86 | 1362 | 8.21 | 1391 | 8.57 | 1420 | 8.94 |
| 9,800 | 1186 | 6.41 | 1213 | 6.70 | 1240 | 7.00 | 1266 | 7.30 | 1293 | 7.62 | 1320 | 7.94 | 1347 | 8.28 | 1374 | 8.62 | 1402 | 8.98 | 1430 | 9.35 |
| 10,000 | 1200 | 6.69 | 1226 | 6.99 | 1252 | 7.29 | 1278 | 7.59 | 1304 | 7.91 | 1331 | 8.23 | 1357 | 8.57 | 1384 | 8.91 | 1411 | 9.27 | 1438 | 9.63 |

LEGEND

Bhp — Brake Horsepower
ESP — External Static Pressure

NOTES:

- Units are available with several motor hp options. Refer to Physical Data table.
- Static pressure losses for any options or accessories must be applied to external static pressure before entering the fan performance table.

- Interpolation is permitted; extrapolation is not.
- Fan performance is based on 1 in. standard throwaway filter, unit casing, and dry DX (direct expansion) coil losses at sea level.

Electrical data



UNIT ELECTRICAL DATA

| UNIT 50XCW | V-PH-Hz | VOLTAGE RANGE | | COMPRESSOR NO. 1 | | COMPRESSOR NO. 2 | |
|---------------|--------------|------------------|-----|---------------------|-----|---------------------|-----|
| | | Min | Max | RLA | LRA | RLA | LRA |
| 06 | 208/230-3-60 | 187 | 253 | 20.5 | 155 | — | — |
| | 460-3-60 | 414 | 506 | 9.6 | 75 | — | — |
| | 575-3-60 | 518 | 632 | 7.6 | 54 | — | — |
| 08 | 208/230-3-60 | 187 | 253 | 22.4 | 149 | — | — |
| | 460-3-60 | 414 | 506 | 10.6 | 75 | — | — |
| | 575-3-60 | 518 | 632 | 7.7 | 54 | — | — |
| 12 | 208/230-3-60 | 187 | 253 | 16.0 | 110 | 16.0 | 110 |
| | 460-3-60 | 414 | 506 | 7.8 | 52 | 7.8 | 52 |
| | 575-3-60 | 518 | 632 | 5.7 | 39 | 5.7 | 39 |
| 14 | 208/230-3-60 | 187 | 253 | 20.5 | 155 | 20.5 | 155 |
| | 460-3-60 | 414 | 506 | 9.6 | 75 | 9.6 | 75 |
| | 575-3-60 | 518 | 632 | 7.6 | 54 | 7.6 | 54 |
| 16 | 208/230-3-60 | 187 | 253 | 23.2 | 164 | 23.2 | 164 |
| | 460-3-60 | 414 | 506 | 11.2 | 75 | 11.2 | 75 |
| | 575-3-60 | 518 | 632 | 7.9 | 54 | 7.9 | 54 |
| 24 | 208/230-3-60 | 187 | 253 | 30.1 | 225 | 30.1 | 225 |
| | 460-3-60 | 414 | 506 | 16.7 | 114 | 16.7 | 114 |
| | 575-3-60 | 518 | 632 | 12.2 | 80 | 12.2 | 80 |

LEGEND

- FLA — Full Load Amps
- LRA — Locked Rotor Amps
- NEC — National Electrical Code
- RLA — Rated Load Amps



NOTES:

1. In compliance with NEC requirements for multimotor and combination load equipment (NEC Articles 430 and 440), the overcurrent protective device for the unit shall be fuse or HACR circuit breaker. Canadian units may be fuse or circuit breaker.
2. Wire sizing amps are a sum of 125% of the compressor RLA plus 100% of indoor fan motor FLA.
3. Motors are protected against primary single phasing condition.
4. Indoor-fan motors are 3-phase motors of same voltage as unit.



FAN ELECTRICAL DATA

| MOTOR CODE | HP | V-PH-Hz | VOLTAGE RANGE | | FLA |
|------------|------|--------------|---------------|-----|-----------|
| | | | Min | Max | |
| B | 0.50 | 208/230-3-60 | 187 | 253 | 1.8/2.2 |
| | | 460-3-60 | 414 | 506 | 1.1 |
| | | 575-3-60 | 518 | 632 | 0.9 |
| C | 0.75 | 208/230-3-60 | 187 | 253 | 2.5/2.6 |
| | | 460-3-60 | 414 | 506 | 1.3 |
| | | 575-3-60 | 518 | 632 | 1.0 |
| D | 1.00 | 208/230-3-60 | 187 | 253 | 3.2/3.2 |
| | | 460-3-60 | 414 | 506 | 1.6 |
| | | 575-3-60 | 518 | 632 | 1.1 |
| E | 1.50 | 208/230-3-60 | 187 | 253 | 4.6/4.8 |
| | | 460-3-60 | 414 | 506 | 2.4 |
| | | 575-3-60 | 518 | 632 | 1.6 |
| F | 2.00 | 208/230-3-60 | 187 | 253 | 6.0/5.8 |
| | | 460-3-60 | 414 | 506 | 2.9 |
| | | 575-3-60 | 518 | 632 | 2.1 |
| G | 3.00 | 208/230-3-60 | 187 | 253 | 9.2/8.6 |
| | | 460-3-60 | 414 | 506 | 4.3 |
| | | 575-3-60 | 518 | 632 | 3.4 |
| H | 5.00 | 208/230-3-60 | 187 | 253 | 14.5/13.6 |
| | | 460-3-60 | 414 | 506 | 6.8 |
| | | 575-3-60 | 518 | 632 | 5.4 |
| J | 7.50 | 208/230-3-60 | 187 | 253 | 21.5/19.4 |
| | | 460-3-60 | 414 | 506 | 9.7 |
| | | 575-3-60 | 518 | 632 | 7.5 |

LEGEND

FLA — Full Load Amps



Typical wiring schematics

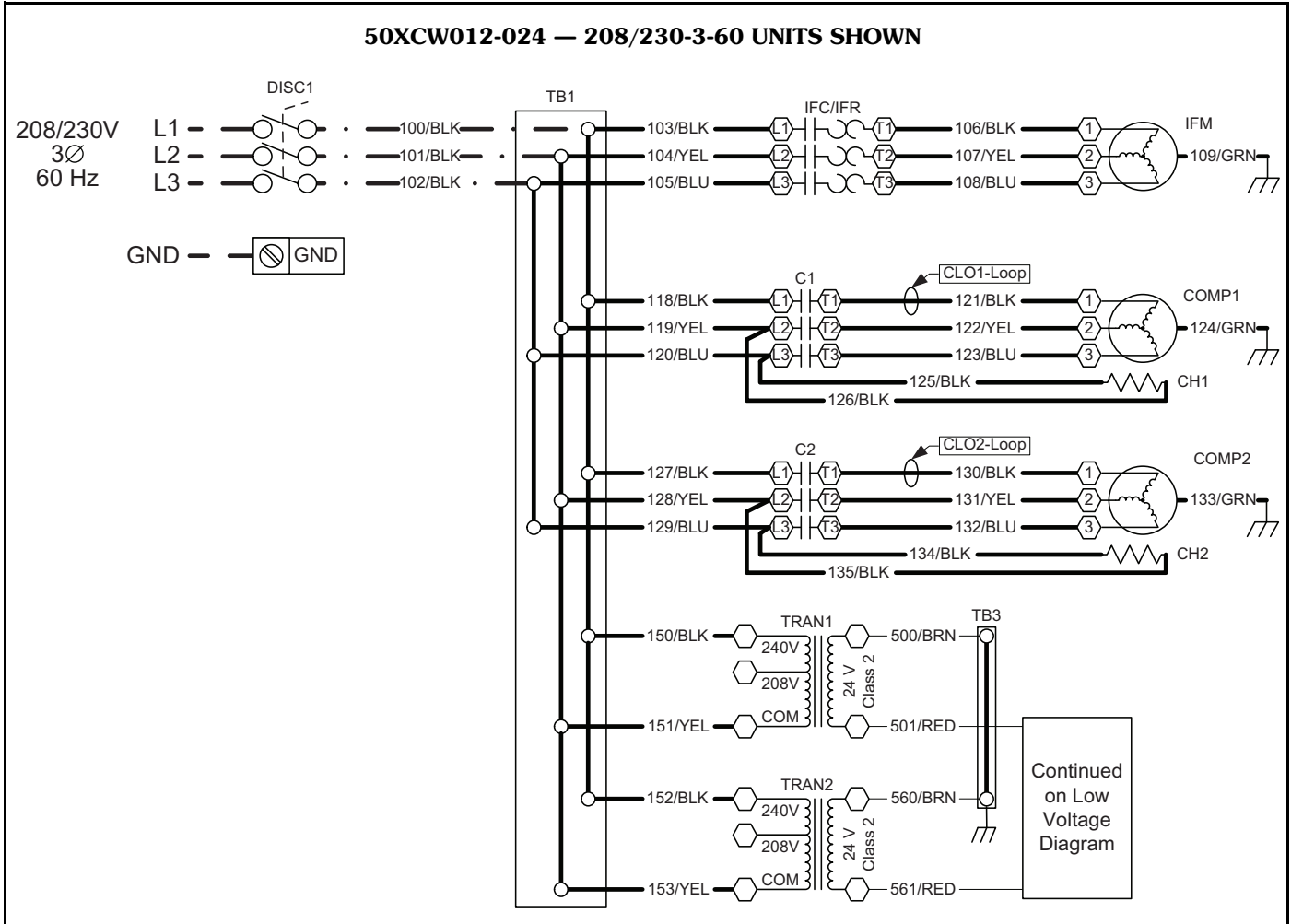

LEGEND AND NOTES FOR WIRING SCHEMATICS

| LEGEND | |
|-----------------------------------|----------------------------|
| C — Compressor Contactor | TB — Terminal Block |
| CH — Crankcase Heater | TRAN — Transformer |
| CLO — Compressor Lockout | Terminal Block Connection |
| COMP — Compressor | Marked Terminal |
| CR — Control Relay | Unmarked Terminal |
| DISC — Disconnect | Splice |
| FRZ — Freeze Protection | Factory Wiring |
| GND — Ground | Field Power Wiring |
| HPS — High Pressure Switch | |
| IFC — Indoor-Fan Contactor | |
| IFM — Indoor-Fan Motor | |
| IFR — Indoor-Fan Relay | |
| LPS — Low Pressure Switch | |

NOTES:

1. Fan motors are inherently thermally protected.
2. Three-phase motors are protected under primary single phase conditions.
3. Use conductors suitable for at least 194 F (90 C) when replacing factory wiring.
4. Use copper conductors only.
5. Wiring for field power supply must be rated at 165 F (75 C) minimum.
6. Phase rotation sequence is L2-L1-L3.
7. TRAN1 and TRAN2 power separate 24-V circuits. These circuits should not be interconnected and separation must be maintained.
8. Transformers are factory wired for 240 v operation. Move the black wire to the 208 v tap for 208 v operation.

50XCW012-024 — 208/230-3-60 UNITS SHOWN (cont)

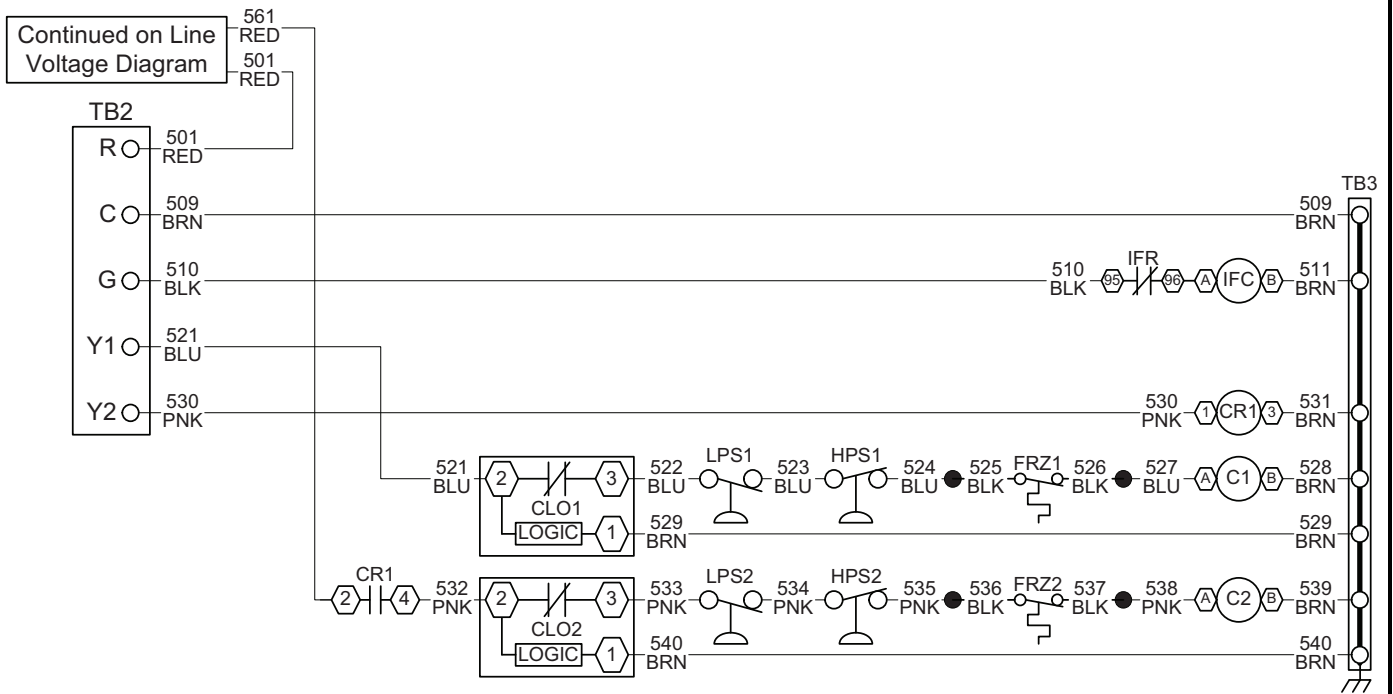

NOTE: Refer to legend and notes on page 36.

Controls



Operating sequence

All units require the addition of a thermostat accessory package to complete the control circuit. The sequence of operation may vary depending on which package is selected.

Room-mounted thermostat — The unit uses a field-supplied electronic thermostat mounted in the conditioned space.

Fan circulation — When the thermostat selector switch is set to the FAN position, the evaporator-fan motor will operate to provide air circulation.

Cooling — The evaporator will operate continuously or when the compressor runs, depending on the setting of the thermostat fan selector switch. When the thermostat closes (on a call for cooling), the compressor contactor(s) close. The control relay will start the indoor fan if it is not already running.

A second stage on 50XCW12 to 24 units will close if additional cooling demand is required, and will start the

second-stage compressor. When the thermostat is satisfied, the second stage compressor will stop first, and then the first stage compressors will stop when cooling demand is satisfied.

A 5-minute timer, TDR (time-delay relay), will prevent the compressor(s) from restarting for 5 minutes after any compressor has stopped.

All units — The control circuit incorporates a current sensing lockout relay (Cycle-LOC™ device) that locks off the compressor(s) when any safety device is activated (low or high pressure switches, or compressor internal overload). If any compressor safety device opens, the compressor will stop. High and low-pressure switches and compressor motor overload protectors will reset automatically when the condition which caused the device to trip has dropped below the reset condition. To reset the Cycle-LOC control device, manually turn the control power OFF, then back ON.

Typical piping and wiring

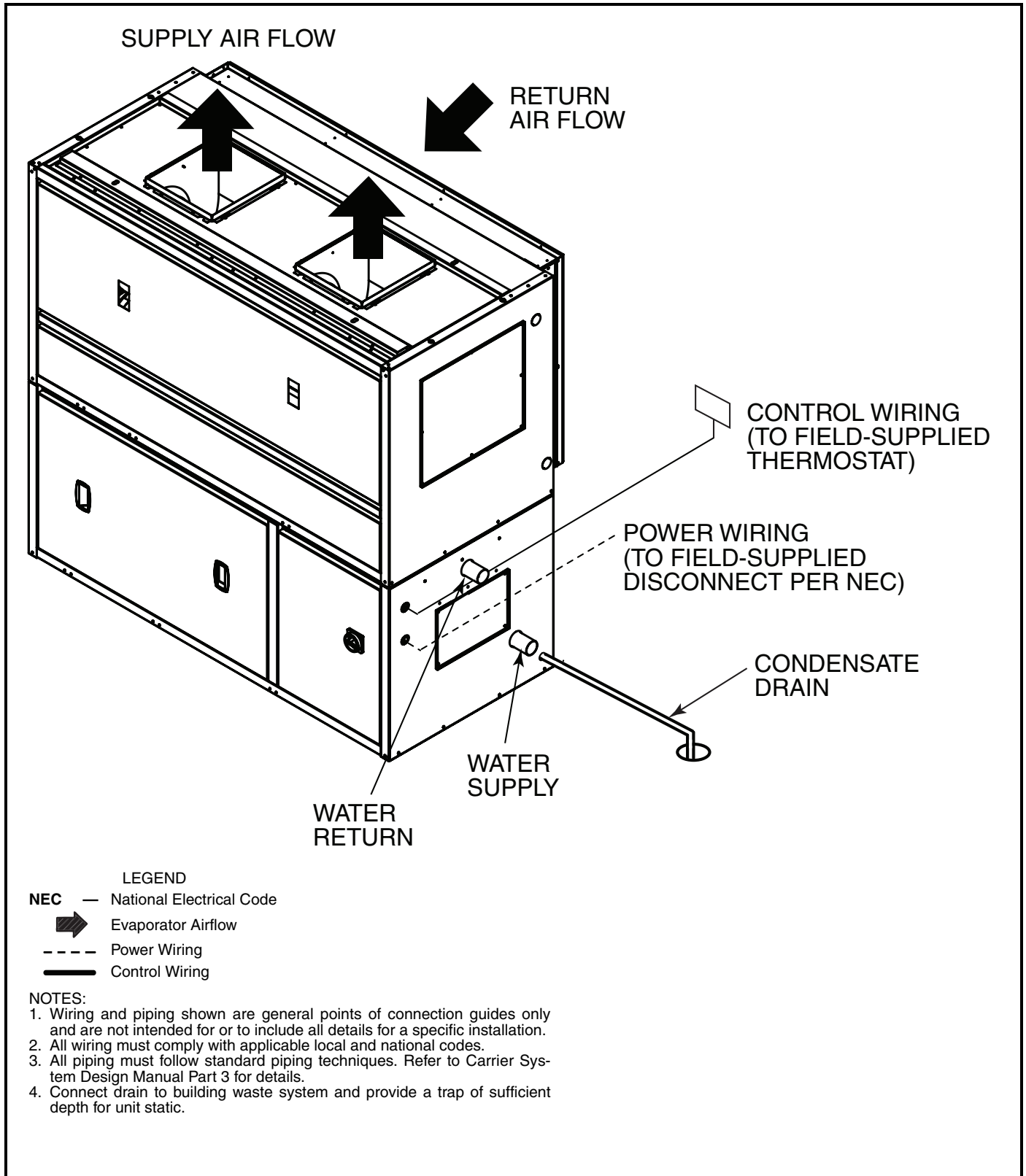

Application data



Location

For best results, the unit must be properly located and installed. Selected location should not be adjacent to an acoustically sensitive location such as a conference room or executive office. The best location is a mechanical room, next to elevators, restrooms or stairways. The mechanical room should be constructed to help isolate the transmission of acoustical energy.

Unit isolation

Unit compressors are internally isolated and the compressor compartment is lined with acoustical insulation. If additional vibration isolation is desired, rubber shear pads are recommended under the 4 corners of the unit. Spring isolation is not recommended.

Ductwork

The supply duct should be properly supported and the aspect ratio as close to square as possible. The duct should be sized for a maximum of 2000 ft/min. velocity in areas outside the equipment room. The duct should be lined with acoustical insulation for a minimum of 10 ft beyond the equipment room. A flexible duct connection should be used on the connection to the unit to prevent transmission of any unit vibrations into the duct.

A return duct may be attached to the unit, but is not necessary. The return to the unit should prevent line of sight visibility to the space. Insulation on the return duct is also recommended. The maximum velocity should not exceed 1000 ft/min. over occupied spaces. An adequate return area is essential for proper unit operation.

Piping

Recommended system piping configuration includes a reverse return system to minimize balancing. A strainer is recommended at the inlet to each unit to prevent sediments from plugging the condensers. Pressure gages are also recommended before the strainer and at the unit outlet to check any potential condenser fouling. Gate type isolation valves are also recommended at each unit to allow service without the need to drain the entire system.

Condenser head pressure control

When tower bypass control is not used and the unit will be required to operate with entering water temperatures below 65 F, a water regulating valve is required. The valve should be located on the water leaving side of the unit condenser. The valve is controlled by the refrigerant pressure of compressor number 1, using the low ambient port connection.

Operational limits

| | |
|--------------------------|---------------------|
| Air Flow: | 300 to 500 cfm/ton |
| Air Temperature Cooling: | Max 115 F, Min 55 F |
| Water Flow: | 2.0 to 4.0 gpm/ton |
| Water Temperature: | Max 100 F, Min 65 F |

Water quality

A good water quality program will ensure years of trouble free unit operation. To establish the best program, a water treatment specialist should be consulted. As a guideline, the following recommendations are made.

| | |
|--|---------|
| Suspended solids over 25 microns (max.): | 200 ppm |
| Chlorides (max.): | 200 ppm |
| Carbon Dioxide (max.): | 20 ppm |
| PH: | 5.5 |
| Sulfides: | < 0.1 |
| Oxygen (max.): | 1.0 ppm |

Operation on ethylene glycol

When the unit will be operated in a system that will use ethylene glycol to prevent freezing, the following table can be used to estimate system performance. Solution concentrations above 40% are not recommended. Capacity and pressure drop from the selection tables are multiplied by the percent factors in the table below.

| % EG | % CAPACITY | % PRESSURE |
|------|------------|------------|
| 0 | 100 | 100 |
| 10 | 98.8 | 104 |
| 20 | 97.2 | 108 |
| 30 | 95.6 | 114 |
| 40 | 95.6 | 124 |

LEGEND

EG — Ethylene Glycol

NOTE: Pressure drop is based on 85 F entering water with 10 F water temperature rise.

Guide specifications



Indoor Self-Contained Water-Cooled Unit Constant Volume Application

HVAC Guide Specifications

Size Range: **5 to 20 Tons**

Carrier Model Number: **50XCW**

Part 1 — General

1.01 SYSTEM DESCRIPTION

Indoor packaged vertical water-cooled cooling unit using hermetic scroll compressors and plate and frame heat exchange. Unit shall discharge supply air vertically or horizontally (units 10 tons and above).

1.02 QUALITY ASSURANCE

- A. Units shall be rated in accordance with ARHI Standard 340/360, latest edition.
- B. Unit shall be designed to conform to ANSI/ASHRAE 15, latest revision safety code, and UL Standard 1995, and shall be UL listed under both American and Canadian Standards.
- C. Unit shall be built in an ISO 9001:2000 certified manufacturing facility and shall be fully run-tested.
- D. Insulation, adhesive, and liner system shall meet NFPA 90A requirements for flame spread and smoke generation.

1.03 DELIVERY, STORAGE, AND HANDLING

Units shall be stored and handled according to manufacturer's recommendations.

Part 2 — Products

2.01 EQUIPMENT

A. General:

Factory-assembled, single-piece, water-cooled cooling unit. Unit shall consist of scroll refrigerant compressor(s), indoor fan section with belt drive centrifugal fans and motor, evaporator coil section with direct expansion coil and drain pan, brazed plate condenser, factory wiring, piping and controls, and a system charge of refrigerant (R-410A). Unit may be used with or without return ductwork.

B. Unit Cabinet:

1. Cabinet shall be constructed of minimum 18 gage zinc surface alloyed steel with a baked enamel finish. Unit shall be capable of withstanding ASTM B117 500-hour salt spray test.
2. Cabinet shall be fully insulated.
3. Unit drain pan shall have positive double slope to the drain to prevent standing water in pan.
4. Panels for servicing shall be easily removable.
5. Return grilles on all units.

C. Evaporator Fan Section:

1. Fans shall be double inlet, centrifugal wheel with forward curved blades designed for continuous operation. Fan wheel and scroll shall be constructed of steel with corrosion resistant finish, and statically and dynamically balanced.

2. Fan shall be belt drive with an adjustable pitch motor pulley and fixed pitch fan pulley, with permanently lubricated ball-bearing type bearings. Units larger than 12 tons use pillow block bearings.
3. Motor shall be 3-phase high-efficiency NEMA frame TEFC (totally enclosed fan cooled) of the same voltage as the compressor(s). Motor shall have permanently lubricated ball bearings.

D. Compressor:

Hermetic scroll compressors shall be internally protected with high pressure relief. Compressors shall be factory rubber shock mounted with internal spring vibration isolators.

E. Coils:

1. Evaporator coil shall have aluminum plate fins mechanically bonded to seamless copper tubes with all joints brazed. Tube sheet openings shall be swaged to prevent tube wear. Coils shall be face split design.
2. Direct expansion coil shall be designed and tested in accordance with ANSI/ASHRAE 15, latest revision safety code.
3. Coil and drain pan shall be accessible through service access panels for cleaning.

F. Filter:

Filter frame shall be installed upstream of the cooling coil, designed to take a 1-in. or 2-in. thick cleanable or disposable type commercially available filter. Filters shall be accessible from either side of the unit and filter rack shall be usable with ducted or free return. Disposable filters will be supplied with the unit.

G. Condenser:

Condenser shall be single pass, water-cooled, ANSI type 316, stainless steel brazed plate construction and shall provide positive subcooling of liquid refrigerant. Condenser shall have a maximum working water side pressure of 400 psig. An independent condenser shall be provided for each refrigerant circuit.

H. Operating Characteristics:

Unit shall be capable of providing a constant volume of conditioned air at a specified static pressure within the unit's normal operating range. Unit shall have dual-stage cooling capacity control on all units sizes 12 to 24. Each compressor shall be on an independent refrigerant circuit. Unit shall be capable of starting and operating at up to 115 F outdoor ambient.

I. Controls and Safeties:

1. Units shall be furnished with a control terminal block for connection of low voltage controls and thermostats.

Guide specifications (cont)



2. Unit shall require a room-mounted thermostat mounted in the conditioned space. Thermostat shall be digital type. Thermostat shall control fan operation and be capable of turning unit on and off.
3. Units shall have the following factory-installed safeties: high and low-pressure switches, motor and compressor overtemperature, current lockout, and inherent automatic fan motor overload.

J. Electrical Requirements:

All electrical power wiring shall enter the unit cabinet at a single location. Control circuit is 24-v, suitable for a field-supplied 24-v thermostat.

K. Refrigerant Components:

Refrigerant circuit components include thermal expansion valves, distributor with nozzle, filter driers, and charging service valves on each circuit. Suction line shall have a refrigerant loop to prevent refrigerant drain back to the compressor. Suction piping shall be insulated with closed cell piping insulation.

L. Special Features:

1. Air Discharge Plenum:

Plenum shall be provided to permit free-blow horizontal air distribution with movable vanes to adjust airflow in horizontal and vertical direction. Plenum is field installed and shall be fully insulated.

2. Heating Coil:

Field-installed hot water coil shall be two rows with copper tube aluminum fins and a powder coated steel casing. Fins shall be bonded to tubes by mechanical expansion. Coil to be leak tested at 400 psi air pressure submerged in water and charged with dry air.

3. Thermostats:

A complete line of thermostats shall be available to meet any application control requirements.

