

**50ZPA
Base 13 SEER
Single-Packaged Air Conditioner System
With R-22 Refrigerant Single and Three Phase
2 to 5 Nominal Tons (Sizes 024-060)**

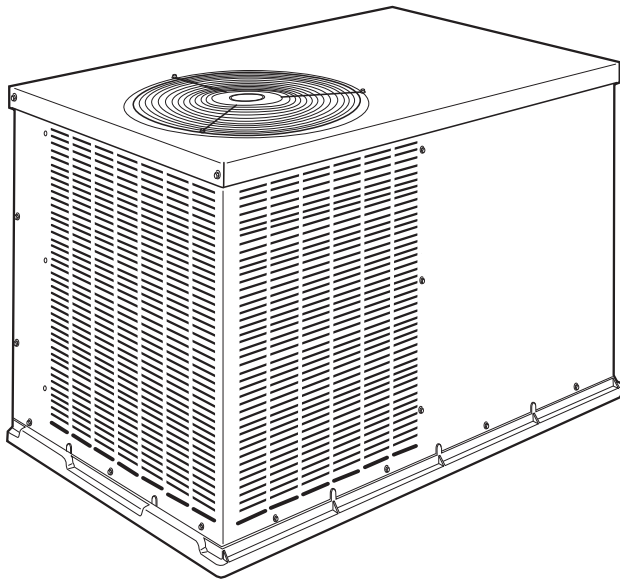

Turn to the Experts.™

Product Data



Unit 50ZPA

A05194

The 50ZPA unit is a packaged air conditioner for manufactured housing, residential, and light commercial applications. The 50ZPA unit design is the result of our firm commitment to the development of the finest air conditioners that modern technology can offer.

The 50ZPA unit is built in one basic cabinet size and features a round side-by-side duct configuration.

FEATURES/BENEFITS

FACTORY-ASSEMBLED PACKAGE is a compact, fully self-contained, electric cooling unit with horizontal supply and return ducts. The 50ZPA units are available in a variety of standard cooling sizes with voltage options to meet residential and light commercial requirements. Unit installs easily on a ground level pad.

EASY TO INSTALL - 50ZPA units are small, compact, and easy to handle. Every 50ZPA unit has an identical 32 x 51-in. (813 x 1295 mm) footprint to make planning simple. The concise design uses less sheet metal and makes the 50ZPA units lighter than other units. The unit can be easily positioned on the job site with the hand holds built into the unit basepan. Drop-in cartridge style heaters are utilized to minimize installation time. The 50ZPA unit was designed with potential safety hazards in mind; with no sharp edges or corners which could injure a worker.

NEW AND IMPROVED AERODYNAMIC FAN BLADE DESIGN reduces the overall sound now as low as 72dBA.

SERVICE ACCESS makes installation and maintenance quicker and easier. The 50ZPA units are designed to be serviced from both the side and rear. The new design allows easy access for installation

and maintenance procedures on the unit. Routine maintenance tasks such as coil cleaning are sped up with the new multiple access side panels.

NO-RUST BASEPAN WITH INTEGRATED DRAIN PAN is standard on all units. The 50ZPA units feature a tough, hightech, composite material basepan with integrated drain pan. The composite material eliminates the potential problems of rust and premature replacement which are common with standard metal basepans.

DURABLE PRE-PAINTED STEEL CABINET protects against harsh weather. The watertight construction and corrosion-resistant finish of the 50ZPA unit will keep it looking like new for years. The paint treatment process ensures quality protection against the elements. A compact, low-profile design utilizes a louvered coil enclosure for protection against vandalism and hail damage.

INDOOR AIR QUALITY is designed into the 50ZPA units. A sloped drain pan minimizes the amount of standing water inside the unit, which limits mold and mildew growth. The drain pan is made of a rust-proof material and will not deteriorate or release foreign matter into the airstream.

LIGHTWEIGHT, COMPACT CONSTRUCTION is ideal for manufactured housing and residential applications. The 50ZPA unit is one of the lightest, most compact packaged units ever designed. It's light weight (268 lb (121.6 kg) for the 50ZPA024 unit) makes the unit easier to handle. The low height keeps ductwork connections to a minimum and makes units less visible.

The 50ZPA units utilize a structural beam design to form the four sides of the cabinet. Only 12 different pieces of sheet metal are used in the unit construction to simplify the unit for greater reliability.

EFFICIENT, DEPENDABLE PERFORMANCE with durable compressors designed for efficiency. The 50ZPA units offer 13.0 SEER (Seasonal Energy Efficiency Ratio) cooling performance efficiencies. This performance level can reduce cooling expenses by as much as 25% compared to older cooling equipment. A high-efficiency, multi-speed blower motor system ensures quality performance with most duct systems. The computer-designed blower wheel is balanced for quiet operation.

DURABLE, DEPENDABLE, COMPRESSORS are designed for high efficiency. Each compressor is hermetically sealed against contamination to help promote longer life and dependable operation. Vibration isolation provides quiet operation. Compressors have internal high-pressure and overcurrent protection.

DIRECT-DRIVE MULTISPEED, BLOWER MOTOR is standard on all models. Direct-drive, PSC condenser-fan motors are designed to help reduce energy consumption and provide for cooling operation down to 40°F (4.4°C).

REFRIGERANT SYSTEM is designed to provide dependability. Liquid refrigerant strainers are used to promote clean, unrestricted operation. Each unit leaves the factory with a full refrigerant charge. Refrigerant service connections make checking operating pressures easier.

ACCESSORY ELECTRIC HEATERS — A variety of accessory electric heaters are available for the 50ZPA units. These heaters are comprised of a separate heater module mounted on the blower inlet and remote mounted controls located in the unit control box. Single point electrical connections are available for powering both the heater and the unit.

LIMITED WARRANTY—Standard 5-year limited warranty on all parts and 5-year limited warranty on compressor.

TABLE OF CONTENTS

	Page
FEATURES/BENEFITS	1-2
MODEL NUMBER NOMENCLATURE	2
ARI CAPACITIES	3
PHYSICAL DATA	3
ACCESSORIES	4
BASE UNIT DIMENSIONS	5
SELECTION PROCEDURE	6
PERFORMANCE DATA	7-13
TYPICAL WIRING SCHEMATICS	14-17
ELECTRICAL DATA	19
OPERATING SEQUENCE	20
TYPICAL INSTALLATION	21
APPLICATION DATA	21
GUIDE SPECIFICATIONS	22

MODEL NUMBER NOMENCLATURE

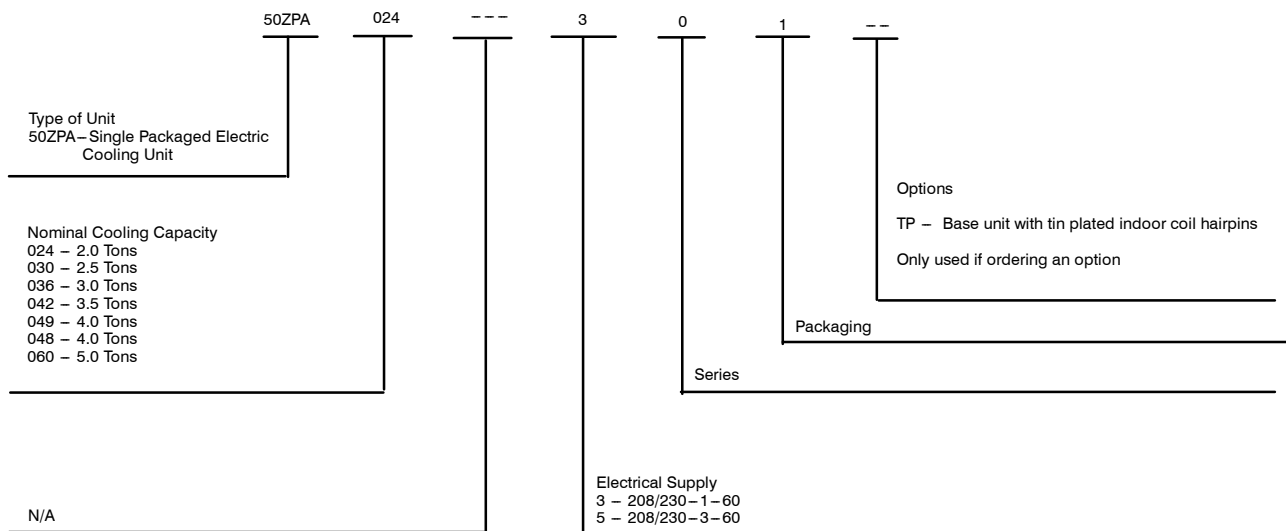

ARI* CAPACITY RATINGS

UNIT 50ZPA (SERIES)	NOMINAL TONS	STANDARD CFM	NET COOLING CAPACITIES AT 95°F (35°C) (Btuh)†	SEER**	SOUND RATINGS‡ (dBA)
024	2.0	800	23,000	13.0	72
030	2.5	1000	28,600	13.2	72
036	3.0	1200	35,000	13.2	75
042	3.5	1400	40,000	13.2	77
049	4.0	1600	46,000	13.2	77
048	4.0	1600	44,500	13.2	77
060	5.0	1900	52,000	13.0	80

* Air Conditioning & Refrigeration Institute.

† Rated in accordance with U.S. Government DOE Department of Energy test procedures and/or ARI Standards 210/240.

‡ Rated in accordance with ARI Standard 270.

**All units have factory-installed time-delay relay.

NOTES:

1. Ratings are net values, reflecting the effects of circulating fan heat.
2. Cooling Standard: 80°F (27°C) db, 67°F (19°C) wb indoor entering air temperature and 95°F (35°C) db outdoor entering-air temperature.

LEGEND

dBA—Decibels – A weighted

db—Dry Bulb

wb—Wet Bulb

SEER—Seasonal Energy Efficiency Ratio



PHYSICAL DATA

UNIT SIZE	024	030	036	042	049	048	060
NOMINAL CAPACITY (ton)	2	2-1/2	3	3-1/2	4	4	5
SHIPPING WEIGHT (lb.)	298	329	382	394	386	389	438
(kg)	135	149	173	179	175	176	199
Compressor	Scroll				Ultra Tech Scroll		
Refrigerant (R-22) Quantity (lb)	6.8	9.5	9.5	11.1	10.0	10.7	12.5
(kg)	3.0	4.3	4.3	5.0	4.5	4.9	5.7
REFRIGERANT METERING DEVICE	AccuRater™				TXV		
Orifice ID (in.)	0.067	0.067	0.082	0.086	—	—	—
CONDENSER COIL	Copper Tubes, Aluminum Plate Fins						
Rows...Fins/in.	2...21	2...21	2...21	2...21	2...21	2...21	2...21
Face Area (sq. ft.)	11.1	12.7	15.8	15.8	13.3	13.3	15.8
CONDENSER FAN	Propeller						
Nominal Cfm	2600	2600	3200	3200	3200	3200	3300
Diameter (in.)	20	20	20	20	20	20	20
(mm)	508	508	508	508	508	508	508
Motor HP (RPM)	1/8 (825)	1/8 (825)	1/4 (1100)	1/4 (1100)	1/4 (1100)	1/4 (1100)	1/2 (1100)
EVAPORATOR COIL	Copper Tubes, Aluminum Plate Fins						
Rows...Fins/in.	3...17	4...17	4...17	4...17	4...17	4...17	4...17
Face Area (sq. ft.)	4.3	4.9	4.9	6.1	4.9	4.9	6.1
Evaporator Blower	Direct Drive						
Nominal Airflow (Cfm)	800	1000	1200	1400	1600	1600	1875
Size (in.)	10 x 8	10 x 8	11 x 9	11 x 9	11 x 10	11 x 10	11 x 10
(mm)	254 x 203.2	254 x 203.2	279.4 x 228.6	279.4 x 228.6	279.4 x 254	279.4 x 254	279.4 x 254
Motor HP (RPM)	1/2 (1050)	1/2 (1050)	3/4 (1050)	3/4 (1050)	1 (1050)	1 (1050)	1 (1050)
CONNECTING DUCT SIZES	Round						
Supply Air (in.)	14						
(mm)	355.6						
Return Air (in.)	14						
(mm)	355.6						
Return-Air Filters Throwaway* (in.)	24 x 24			30 x 30			
(mm)	610 x 610			762 x 762			

*Required filter sizes shown are based on the ARI (Air Conditioning and Refrigeration Institute) rated airflow at a velocity of 300 ft/min for throwaway type or 450 ft/min for high capacity type. Recommended filters are 1-in. (25.4 mm) thick.

50ZPA

ACCESSORIES

Corporate Thermostat — These provide cooling control for unit. Autochangeover and manual changeover types are available.

The MotorMaster II® Low Ambient Kit — Kit permits operation down to 0°F (-17.8°C). Use when mechanical cooling is required when outdoor air temperature is between 40°F (4.4°C) and 0°F (-17.8°C).

Crankcase Heater — Warms crankcase oil to reduce refrigerant migration and ensure proper compressor lubrication. Recommended for low ambient or commercial applications.

Solid-State Time Guard® Device Package — Consists of a control to be field-wired into the unit controls, and provides a 5-minute delay in compressor operation between cooling cycles. Prevents compressor short cycling when rapid compressor cycles may be a problem.

Controls Upgrade Kit — Contains high- and low-pressure switches to protect the unit from running at unsuitable pressures. Provides additional safety features when needed.

Outdoor Thermostat — Accessory provides control when outdoor-air temperature falls below set point. Helps to bring second stage of 2-stage electric heater on line.

Electric Heaters ranging from 5.0 to 20.0 kW provide heat in the unit when required. Each package has a heater module that mounts on the blower inlet; mounting this module requires removal of the blower assembly and attachment of the module to the blower standoffs provided. Each package also includes an associated heater control package that must be mounted in the unit control box. Integral harnesses provided with both the heater module and control package allow connection of the two components via in-line plugs. Approved heaters could be with or without circuit breakers and provide the ability to supply power to the entire unit from a single circuit.

Accessory Electric Heaters

CATALOG ORDERING NO.	NOMINAL CAPACITY (kW)	USED WITH SIZES								
		CIRCUIT BREAKER (Yes/No)	STAGES	024	030	036	042	049	048	060
ELECTRIC HEATERS (208/230--SINGLE PHASE--60Hz)										
CPHEATER096A00	3.8 / 5.0	No	1	X	X	X	X	X	X	X
CPHEATER098A00	5.6 / 7.5	No	2	X	X	X	X	X	X	X
CPHEATER100A00	7.5 / 10.0	No	2	X	X	X	X			
CPHEATER101A00	7.5 / 10.0	Yes	2					X	X	X
CPHEATER102A00	11.3 / 15.0	Yes	2		X	X	X	X	X	X
CPHEATER103A00	15.0 / 20.0	Yes	2			X	X	X	X	X
ELECTRIC HEATERS (208/230--THREE PHASE--60Hz)										
CPHEATER115A00	3.8/5	No	2		X	X	X	X	X	X
CPHEATER116A00	7.5/10	No	2		X	X	X	X	X	X
CPHEATER118A00	11.3/15	No	2		X	X	X	X	X	X
CPHEATER120A00	15.0/20	Yes	2			X	X	X	X	X

X=Approved combination

Multiplication Factors

HEATER kW RATING	VOLTAGE DISTRIBUTION	MULTIPLICATION FACTOR
240	200	.69
	208	.75
	230	.92
	240	1.00

Example: 15.0 kW (at 240v) heater on 208v
 = 15.0 (.75 mult factor)
 = 11.25 capacity at 208v

DIMENSIONAL DRAWINGS — 50ZPA024-060

UNIT	ELECTRICAL CHARACTERISTICS	UNIT WT.			UNIT HEIGHT			CENTER OF GRAVITY MM/IN		
		LBS.	KG.	A	X	Y	Z			
50ZPA024	208-230-1-60	268	122	30.13 [765]	14.0 [356]	19.0 [483]	15.0 [381]			
50ZPA030	208-230-1-60	299	136	34.13 [867]	14.0 [356]	19.0 [483]	16.0 [406]			
50ZPA036	208-230-1-60	352	160	42.13 [1070]	14.0 [356]	19.0 [483]	19.8 [503]			
50ZPA042	208-230-1-60	364	165	42.13 [1070]	14.0 [356]	19.0 [483]	21.9 [556]			
50ZPA049	208-230-1-60	356	161	42.13 [1070]	14.0 [356]	19.0 [483]	19.8 [503]			
50ZPA048	208-230-1-60	359	163	42.13 [1070]	14.0 [356]	19.0 [483]	19.8 [503]			
50ZPA060	208-230-1-60	408	185	42.13 [1070]	14.0 [356]	19.0 [483]	21.9 [556]			

REQUIRED CLEARANCES TO COMBUSTIBLE MATL.

TOP OF UNIT.....	0
BOTTOM OF UNIT.....	0
SIDE OF UNIT WITH DUCT OPENINGS.....	0
SIDE OF UNIT OPPOSITE DUCT OPENINGS.....	0

NEC REQUIRED CLEARANCES

BETWEEN UNITS, POWER ENTRY SIDE.....	1066.8 [42.00]
AND GROUNDING CONDUCTOR ENTRY SIDE.....	914.0 [36.00]
UNIT AND SURFACES, POWER ENTRY SIDE.....	1066.8 [42.00]
AND SURFACES, POWER ENTRY SIDE.....	1066.8 [42.00]

REQUIRED CLEARANCE FOR SERVICING

TOP OF UNIT.....	914.0 [36.00]
SIDE OF UNIT OPPOSITE DUCT OPENINGS.....	762.0 [30.00]
SIDE OF UNIT WITH POWER ENTRY.....	762.0 [30.00]
(EXCEPT FOR NEC REQUIREMENTS)	

NOTE: CLEARANCES MUST BE MAINTAINED TO PREVENT RECIRCULATION OF AIR FROM OUTDOOR FAN DISCHARGE. A REMOVABLE FENCE OR BARRICADE REQUIRES NO CLEARANCE.

DIMENSIONS IN () ARE IN INCHES

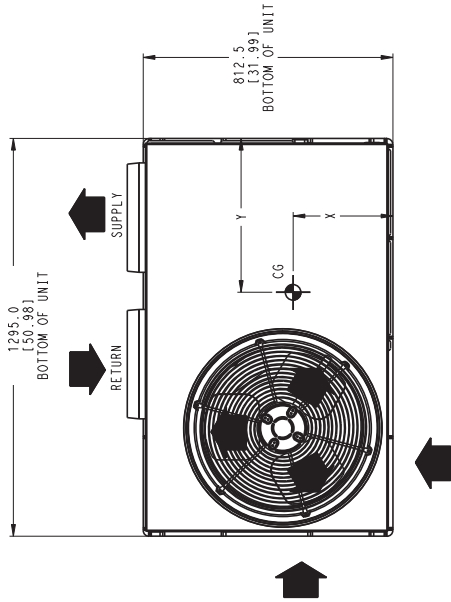

TOP VIEW

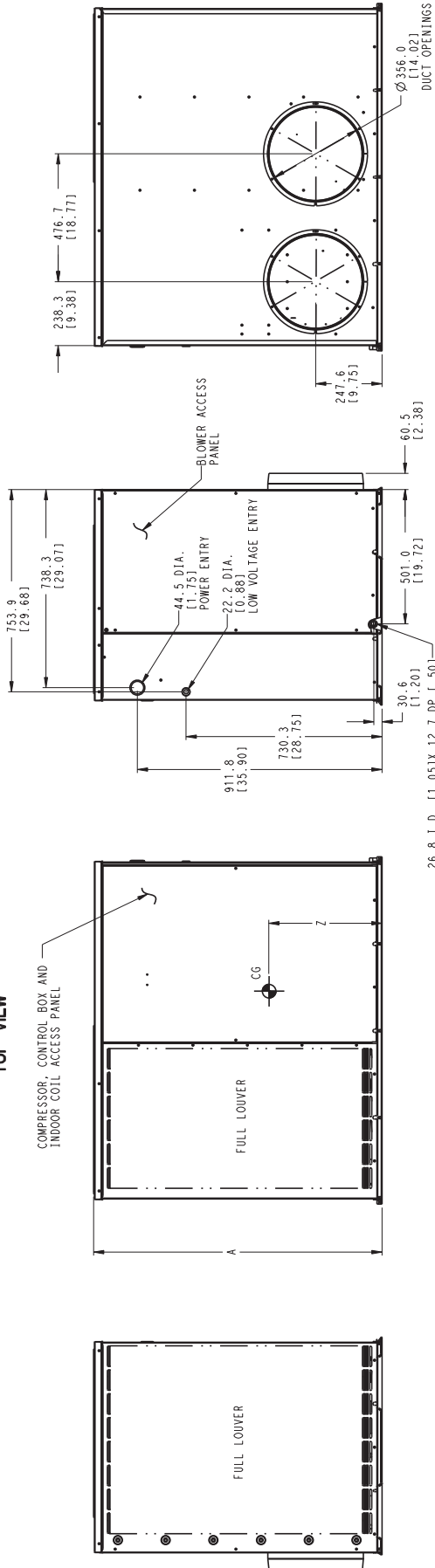

LEFT SIDE VIEW

FRONT VIEW

RIGHT SIDE VIEW

REAR VIEW

26.8 I.D. [1.05] X 12.7 DP [I.50]
CONDENSATE DRAIN

50ZP500624	REV 4.0
------------	---------

50ZPA

PERFORMANCE DATA

Cooling Capacities

50ZPA024

EVAPORATOR AIR		CONDENSER ENTERING AIR TEMPERATURES ° F (° C)																	
		75 (24)			85 (29)			95 (35)			105 (41)			115 (46)			125 (52)		
		Capacity MBtuh		Total System KW	Capacity MBtuh		Total System KW	Capacity MBtuh		Total System KW	Capacity MBtuh		Total System KW	Capacity MBtuh		Total System KW	Capacity MBtuh		Total System KW
CFM / BF	EWB ° F (° C)	Total	Sens	Total System KW	Total	Sens	Total System KW	Total	Sens	Total System KW	Total	Sens	Total System KW	Total	Sens	Total System KW	Total	Sens	
		700 / 0.08	57 (14)		19.86	19.86		1.7	19.13		19.13	1.9		18.37	18.37		2.1	17.54	17.54
	62 (17)	20.44	20.44	1.7	19.51	19.51	1.9	18.57	18.57	2.1	17.57	17.57	2.3	16.62	16.62	2.5	15.67	15.67	2.8
	63* (17)	20.88	16.50	1.7	19.93	16.14	1.9	18.96	15.74	2.1	17.90	15.22	2.3	16.73	14.56	2.5	15.69	14.07	2.8
	67 (19)	22.63	17.20	1.7	21.56	16.82	1.9	20.54	16.23	2.1	19.45	15.75	2.3	18.27	15.35	2.6	17.18	14.88	2.8
	72 (22)	24.74	13.85	1.7	23.91	13.63	1.9	22.83	13.01	2.1	21.68	12.57	2.4	20.41	12.04	2.6	19.33	11.59	2.9
	57 (14)	20.72	20.72	1.8	19.94	19.94	2.0	19.14	19.14	2.2	18.28	18.28	2.4	17.33	17.33	2.6	16.48	16.48	2.9
	62 (17)	20.96	20.96	1.8	20.01	19.81	2.0	19.14	19.14	2.2	18.27	18.27	2.4	17.33	17.33	2.6	16.42	16.16	2.9
	63* (17)	21.41	17.77	1.8	20.41	17.35	2.0	19.39	16.87	2.2	18.30	16.29	2.4	17.10	15.73	2.6	16.02	15.22	2.9
	67 (19)	23.18	18.54	1.8	22.12	17.92	2.0	23.00	17.43	2.2	19.88	16.90	2.4	18.66	16.42	2.6	17.53	15.89	2.9
	72 (22)	25.18	14.60	1.8	24.43	14.17	2.0	23.36	13.78	2.2	22.19	13.31	2.4	20.85	12.93	2.7	19.77	12.51	2.9
	57 (14)	21.48	21.48	1.8	20.64	20.64	2.0	19.80	19.80	2.2	18.90	18.90	2.5	17.92	17.92	2.7	17.03	17.03	3.0
	62 (17)	21.55	21.55	1.8	20.64	20.64	2.0	19.80	19.80	2.2	18.90	18.90	2.5	17.92	17.92	2.7	17.01	17.01	3.0
	63* (17)	21.85	17.26	1.8	20.78	16.83	2.0	19.73	16.38	2.2	18.61	15.82	2.5	17.38	15.29	2.7	16.26	14.80	3.0
	67 (19)	23.59	17.93	1.9	22.54	17.58	2.0	21.36	17.09	2.3	20.20	16.56	2.5	18.95	16.11	2.7	17.79	15.65	3.0
	72 (22)	24.18	12.33	1.9	24.80	13.64	2.1	23.77	13.31	2.3	22.58	12.87	2.5	21.24	12.32	2.8	20.51	12.32	3.0

50ZPA030

EVAPORATOR AIR		CONDENSER ENTERING AIR TEMPERATURES ° F (° C)																	
		75 (24)			85 (29)			95 (35)			105 (41)			115 (46)			125 (52)		
		Capacity MBtuh		Total System KW	Capacity MBtuh		Total System KW	Capacity MBtuh		Total System KW	Capacity MBtuh		Total System KW	Capacity MBtuh		Total System KW	Capacity MBtuh		Total System KW
CFM / BF	EWB ° F (° C)	Total	Sens	Total System KW	Total	Sens	Total System KW	Total	Sens	Total System KW	Total	Sens	Total System KW	Total	Sens	Total System KW	Total	Sens	
		875 / 0.08	57 (14)		26.73	26.73		2.1	25.73		25.73	2.3		24.73	24.73		2.5	23.67	23.67
	62 (17)	27.76	25.54	2.1	26.46	24.87	2.3	25.21	24.20	2.5	23.89	23.65	2.8	22.53	22.53	3.0	21.22	21.78	3.3
	63* (17)	28.46	21.06	2.1	27.06	20.30	2.3	25.78	19.59	2.5	24.42	19.05	2.8	22.95	18.36	3.0	21.57	17.68	3.3
	67 (19)	30.79	21.86	2.1	29.39	21.16	2.3	28.01	20.45	2.6	26.53	19.90	2.8	25.02	19.27	3.1	23.58	18.62	3.3
	72 (22)	33.42	17.38	2.1	32.32	17.13	2.3	31.00	16.43	2.6	29.60	15.98	2.8	28.06	15.43	3.1	26.72	14.95	3.4
	57 (14)	27.84	27.84	2.2	26.76	26.76	2.4	25.72	25.72	2.6	24.62	24.62	2.8	23.42	23.42	3.1	22.32	22.32	3.4
	62 (17)	28.43	27.29	2.2	27.04	26.50	2.4	25.77	25.77	2.6	24.61	24.61	2.8	23.42	23.42	3.1	22.17	22.45	3.4
	63* (17)	29.08	22.10	2.2	27.58	21.51	2.4	26.24	20.99	2.6	24.85	20.38	2.8	23.34	19.61	3.1	21.91	18.98	3.4
	67 (19)	31.38	22.91	2.2	29.98	22.49	2.4	28.60	22.02	2.6	27.07	21.39	2.9	25.44	20.61	3.1	23.96	20.03	3.4
	72 (22)	33.81	17.92	2.2	32.79	17.71	2.4	31.51	16.84	2.6	30.08	16.84	2.9	28.59	16.30	3.2	27.29	15.89	3.5
	57 (14)	28.81	28.81	2.3	27.67	27.67	2.5	26.57	26.57	2.7	25.40	25.40	2.9	24.19	24.19	3.2	23.04	23.04	3.5
	62 (17)	28.98	28.98	2.3	27.67	27.67	2.5	26.56	26.56	2.7	25.40	25.40	2.9	24.18	24.18	3.2	22.98	22.98	3.5
	63* (17)	29.54	23.34	2.3	28.05	22.72	2.5	26.82	22.09	2.7	25.18	21.40	2.9	23.64	20.80	3.2	22.17	20.17	3.5
	67 (19)	31.80	24.17	2.3	30.42	23.73	2.5	28.97	23.18	2.7	27.45	22.51	3.0	25.78	21.91	3.2	24.28	21.35	3.5
	72 (22)	34.04	18.38	2.3	33.09	18.20	2.5	31.86	17.84	2.7	30.42	17.64	3.0	28.93	17.07	3.3	27.65	16.74	3.6

See Legend and Notes on page 11.

COOLING CAPACITIES (CONT)

50ZPA036

EVAPORATOR AIR		CONDENSER ENTERING AIR TEMPERATURES °F (°C)																	
		75 (24)			85 (29)			95 (35)			105 (41)			115 (46)			125 (52)		
		CFM / BF	EWB °F (°C)	Capacity MBtuh		Total System KW	Capacity MBtuh		Total System KW	Capacity MBtuh		Total System KW	Capacity MBtuh		Total System KW	Capacity MBtuh		Total System KW	
Total	Sens			Total	Sens		Total	Sens		Total	Sens		Total	Sens		Total	Sens		
1050 / 0.07	57 (14)	32.66	32.66	2.6	31.63	31.63	2.9	30.54	30.54	3.2	29.41	29.41	3.5	28.22	28.22	3.9	27.11	27.11	4.3
	62 (17)	33.89	29.48	2.6	32.58	28.67	2.9	31.21	28.09	3.2	29.80	27.42	3.5	28.35	28.07	3.8	26.97	27.71	4.2
	63* (17)	34.61	23.88	2.6	33.26	23.28	2.9	31.87	22.63	3.2	30.41	22.20	3.5	28.89	21.38	3.8	27.46	20.75	4.2
	67 (19)	37.24	24.95	2.7	35.81	24.35	2.9	34.32	23.68	3.2	32.78	22.95	3.5	31.16	22.44	3.9	29.64	21.81	4.2
	72 (22)	40.89	20.04	2.6	39.35	19.68	2.9	37.74	18.87	3.2	36.07	18.40	3.5	34.33	17.85	3.9	32.69	17.31	4.2
1200 / 0.08	57 (14)	34.06	34.06	2.7	32.95	32.95	2.9	31.80	31.80	3.3	30.60	30.60	3.6	29.34	29.34	4.0	28.16	28.16	4.4
	62 (17)	34.68	31.56	2.7	33.33	30.66	3.0	31.94	31.62	3.2	30.60	30.60	3.5	29.33	29.33	3.9	27.99	28.77	4.2
	63* (17)	35.37	25.47	2.7	33.96	24.79	3.0	32.51	24.38	3.2	30.99	23.55	3.5	29.42	22.95	3.9	27.93	22.32	4.3
	67 (19)	38.04	26.25	2.7	36.55	25.95	3.0	35.00	25.20	3.3	33.39	24.71	3.6	31.71	23.78	3.9	30.13	23.17	4.3
	72 (22)	41.76	21.30	2.8	40.15	20.48	3.0	38.48	20.01	3.3	36.75	19.48	3.6	34.94	18.87	3.9	33.24	18.26	0.3
1350 / 0.10	57 (14)	35.24	35.24	2.7	34.08	34.08	3.0	32.87	32.87	3.4	31.61	31.61	3.7	30.28	30.28	4.1	29.04	29.04	4.5
	62 (17)	35.39	35.04	2.8	34.08	34.08	3.1	32.87	32.87	3.3	31.61	31.61	3.6	30.28	30.28	4.0	29.00	29.09	4.3
	63* (17)	35.96	26.97	2.8	34.51	26.23	3.1	33.00	25.74	3.3	31.45	25.16	3.6	29.83	24.46	3.9	28.30	23.83	4.3
	67 (19)	38.66	27.84	2.8	37.12	27.47	3.1	35.52	26.64	3.4	33.86	26.07	3.7	32.14	25.39	4.0	30.51	24.78	4.3
	72 (22)	42.44	22.07	2.8	40.78	21.61	3.1	39.06	21.09	3.4	37.27	20.50	3.7	35.41	19.83	4.0	33.65	19.27	4.4

50ZPA042

EVAPORATOR AIR		CONDENSER ENTERING AIR TEMPERATURES °F (°C)																	
		75 (24)			85 (29)			95 (35)			105 (41)			115 (46)			125 (52)		
		CFM / BF	EWB °F (°C)	Capacity MBtuh		Total System KW	Capacity MBtuh		Total System KW	Capacity MBtuh		Total System KW	Capacity MBtuh		Total System KW	Capacity MBtuh		Total System KW	
Total	Sens			Total	Sens		Total	Sens		Total	Sens		Total	Sens		Total	Sens		
1225 / 0.11	57 (14)	37.90	37.90	3.0	36.10	36.10	3.4	35.10	35.10	3.7	32.80	32.80	4.1	31.30	31.30	4.5	28.00	28.00	5.0
	62 (17)	38.80	38.41	3.3	36.70	37.43	3.4	35.90	35.90	3.7	33.90	33.56	4.0	32.20	32.20	4.3	28.60	28.50	4.9
	63* (17)	40.20	28.94	3.3	38.50	31.19	3.4	36.70	27.53	3.7	34.30	26.41	4.0	32.30	25.52	4.3	27.40	24.70	4.9
	67 (19)	40.90	29.04	3.2	40.10	31.28	3.4	39.30	28.30	3.7	36.80	27.23	4.0	34.80	26.45	4.4	31.30	25.10	4.8
	72 (22)	43.70	22.29	3.6	42.70	24.34	3.6	42.20	22.37	3.7	39.30	21.22	4.0	36.00	19.08	4.3	33.00	19.50	5.1
1400 / 0.12	57 (14)	37.70	37.70	3.1	37.20	37.20	3.4	36.60	36.60	3.8	34.80	34.80	4.0	33.90	33.90	4.6	28.20	28.20	4.7
	62 (17)	40.30	39.90	3.3	38.60	38.21	3.5	37.20	37.20	3.8	35.20	35.20	4.0	34.10	33.76	4.7	28.80	28.60	4.7
	63* (17)	39.60	30.10	3.3	39.00	30.03	3.5	37.40	29.55	3.8	34.90	28.27	4.0	33.40	28.72	4.4	27.60	24.90	4.7
	67 (19)	43.90	31.83	3.3	40.60	30.86	3.6	40.00	30.40	3.8	37.40	29.53	4.1	36.00	30.24	4.4	30.00	26.10	4.8
	72 (22)	43.90	23.27	3.3	43.60	23.98	3.5	42.40	23.32	3.8	39.70	22.23	4.1	39.90	22.74	4.5	32.90	19.40	5.1
1575 / 0.14	57 (14)	37.60	37.60	3.4	37.40	37.40	3.6	37.00	37.00	3.8	33.90	33.90	4.1	32.10	32.10	4.8	29.00	29.00	4.9
	62 (17)	40.10	38.10	3.4	39.80	39.40	3.6	38.10	37.72	3.8	34.10	33.76	4.1	32.70	32.37	4.8	29.70	29.50	4.9
	63* (17)	40.20	31.36	3.5	39.60	32.08	3.6	36.50	30.66	3.8	33.40	28.72	4.1	32.70	29.80	4.8	27.90	27.20	4.8
	67 (19)	42.50	32.73	3.4	42.20	33.34	3.6	40.50	32.81	3.9	36.00	30.24	4.1	32.70	30.03	4.8	30.60	28.00	4.8
	72 (22)	44.70	24.59	3.4	44.60	25.42	3.6	42.80	24.82	3.9	39.90	22.74	4.2	36.60	22.33	4.9	32.80	18.10	4.9

See Legend and Notes on page 11.

COOLING CAPACITIES (CONT)

50ZPA049

EVAPORATOR AIR		CONDENSER ENTERING AIR TEMPERATURES °F (°C)																	
		75 (24)			85 (29)			95 (35)			105 (41)			115 (46)			125 (52)		
		CFM / BF	EWB °F (°C)	Capacity MBtuh		Total System KW	Capacity MBtuh		Total System KW	Capacity MBtuh		Total System KW	Capacity MBtuh		Total System KW	Capacity MBtuh		Total System KW	
Total	Sens			Total	Sens		Total	Sens		Total	Sens		Total	Sens		Total	Sens		
	57 (14)	43.90	43.90	3.05	42.26	42.26	3.52	40.57	40.57	4.04	38.82	38.82	4.64	37.02	37.02	5.30	35.17	35.17	6.04
	62 (17)	45.10	43.19	3.06	43.11	41.55	3.53	41.07	39.90	4.05	39.01	38.22	4.64	37.02	37.02	5.30	35.17	35.17	6.04
1400 / 0.07	63* (17)	46.00	35.30	3.07	43.94	33.84	3.54	41.83	32.37	4.06	39.67	30.92	4.65	37.45	29.46	5.31	35.17	28.02	6.03
	67 (19)	49.52	36.49	3.11	47.34	35.02	3.58	45.11	33.55	4.11	42.81	32.08	4.71	40.47	30.82	5.38	38.06	29.16	6.11
	72 (22)	54.55	29.74	3.16	52.19	28.41	3.64	49.78	27.08	4.18	47.31	25.76	4.79	44.78	24.46	5.46	42.20	23.16	6.21
	57 (14)	45.87	45.87	3.12	44.13	44.13	3.59	42.33	42.33	4.13	40.47	40.47	4.73	38.57	38.57	5.40	36.61	36.61	6.14
	62 (17)	46.26	46.57	3.12	44.23	43.93	3.59	42.32	42.32	4.13	40.47	40.47	4.73	38.57	38.57	5.40	36.60	36.60	6.14
1600 / 0.08	63* (17)	47.01	37.73	3.13	44.87	36.20	3.60	42.68	34.68	4.13	40.43	33.15	4.72	38.14	31.64	5.39	35.79	30.13	6.11
	67 (19)	50.59	39.08	3.17	48.32	37.54	3.65	46.00	36.00	4.18	43.62	34.47	4.78	41.19	32.94	5.45	38.71	31.42	6.19
	72 (22)	55.71	31.39	3.22	53.26	30.01	3.71	50.75	28.64	4.25	48.18	27.28	4.86	45.56	25.92	5.54	42.88	24.58	6.29
	57 (14)	47.54	47.54	3.19	45.70	45.70	3.66	43.81	43.81	4.20	41.86	41.86	4.81	39.86	39.86	5.48	37.80	37.80	6.23
	62 (17)	47.54	47.54	3.19	45.70	45.70	3.66	43.81	43.81	4.20	41.86	41.86	4.81	39.86	39.86	5.48	37.80	37.80	6.23
1800 / 0.09	63* (17)	47.79	40.09	3.19	45.59	38.50	3.66	43.33	36.91	4.19	41.03	35.32	4.79	38.67	33.73	5.46	36.27	32.15	6.19
	67 (19)	51.42	41.59	3.23	49.08	39.99	3.71	46.69	38.38	4.25	44.25	36.78	4.85	41.75	35.19	5.52	39.22	33.60	6.27
	72 (22)	56.60	32.98	3.28	54.07	31.56	3.77	51.48	30.15	4.31	48.84	28.75	4.93	46.14	27.35	5.61	43.39	25.97	6.36

50ZPA048 High Capacity

EVAPORATOR AIR		CONDENSER ENTERING AIR TEMPERATURES °F (°C)																	
		75 (24)			85 (29)			95 (35)			105 (41)			115 (46)			125 (52)		
		CFM / BF	EWB °F (°C)	Capacity MBtuh		Total System KW	Capacity MBtuh		Total System KW	Capacity MBtuh		Total System KW	Capacity MBtuh		Total System KW	Capacity MBtuh		Total System KW	
Total	Sens			Total	Sens		Total	Sens		Total	Sens		Total	Sens		Total	Sens		
	57 (14)	41.83	41.83	3.6	40.45	40.45	3.9	38.95	38.95	4.3	37.33	37.33	4.7	35.59	35.59	5.2	35.30	34.50	5.6
	62 (17)	43.10	39.65	3.6	41.39	38.91	3.9	39.50	37.92	4.3	37.48	37.11	4.7	35.59	35.59	5.2	35.40	34.50	5.6
1400 / 0.07	63* (17)	43.99	32.55	3.6	42.33	31.75	3.9	40.42	30.72	4.3	38.31	29.88	4.7	36.03	28.82	5.2	35.30	28.10	5.6
	67 (19)	46.97	33.35	3.6	45.55	32.80	4.0	43.72	31.92	4.3	41.63	31.22	4.7	39.31	30.27	5.2	38.10	29.40	5.7
	72 (22)	50.32	26.17	3.6	49.32	26.14	4.0	47.83	25.83	4.4	45.99	24.83	4.7	43.84	24.11	5.2	42.00	23.00	5.7
	57 (14)	43.63	43.63	3.7	42.24	42.24	4.0	40.68	40.68	4.4	38.99	38.99	4.8	37.17	37.17	5.2	36.80	35.90	5.7
	62 (17)	44.04	42.72	3.7	42.38	41.96	4.0	40.68	40.68	4.4	38.98	38.98	4.8	37.16	37.16	5.2	36.80	36.00	5.7
1600 / 0.08	63* (17)	44.78	34.48	3.7	43.15	33.66	4.0	41.22	32.98	4.4	39.05	32.02	4.8	36.71	30.84	5.2	36.00	30.30	5.7
	67 (19)	47.65	35.26	3.7	46.31	35.20	4.0	44.50	34.27	4.4	42.39	33.49	4.8	40.04	32.43	5.3	38.90	31.80	5.7
	72 (22)	50.84	27.45	3.7	49.90	27.45	4.1	48.50	27.16	4.4	46.86	26.60	4.9	44.51	25.82	5.3	42.80	24.50	5.8
	57 (14)	45.02	45.02	3.8	43.69	43.69	4.1	42.12	42.12	4.5	40.37	40.37	4.9	38.49	38.49	5.3	38.00	37.10	5.8
	62 (17)	45.01	45.01	3.8	43.69	43.69	4.1	42.11	42.11	4.5	40.37	40.37	4.9	38.48	38.48	5.3	38.10	37.20	5.8
1800 / 0.09	63* (17)	45.32	36.26	3.8	43.74	35.87	4.1	41.81	35.12	4.5	39.62	34.07	4.9	37.24	33.14	5.3	36.60	32.40	5.8
	67 (19)	48.08	37.02	3.8	46.83	37.00	4.1	45.06	36.50	4.5	42.94	35.64	4.9	40.64	34.54	5.4	39.40	34.10	5.8
	72 (22)	51.19	28.15	3.8	50.28	28.16	4.2	48.94	28.39	4.5	47.15	27.82	4.9	44.96	26.98	5.4	43.30	26.00	5.9

See Legend and Notes on page 11.

COOLING CAPACITIES (CONT)

50ZPA048 Low Capacity

EVAPORATOR AIR		CONDENSER ENTERING AIR TEMPERATURES °F (°C)																	
		75 (24)			85 (29)			95 (35)			105 (41)			115 (46)			125 (52)		
		Capacity MBtuh		Total System KW	Capacity MBtuh		Total System KW	Capacity MBtuh		Total System KW	Capacity MBtuh		Total System KW	Capacity MBtuh		Total System KW	Capacity MBtuh		Total System KW
CFM / BF	EWB °F (°C)	Total	Sens	KW	Total	Sens	KW	Total	Sens	KW	Total	Sens	KW	Total	Sens	KW	Total	Sens	KW
		57 (14)	29.40		28.70	2.1		28.60	28.00		2.4	27.80		27.10	2.8		26.90	26.30	
62 (17)	30.30	27.40	2.1	29.30	26.90	2.4	28.20	26.40	2.8	27.10	25.90	3.1	26.00	25.30	3.5	24.90	24.30	3.9	
63* (17)	30.80	22.20	2.1	29.80	21.70	2.4	28.70	21.30	2.8	27.50	20.80	3.1	26.30	20.30	3.5	25.00	19.70	3.9	
67 (19)	33.10	23.00	2.2	30.80	22.10	2.5	30.80	22.10	2.8	29.60	21.60	3.2	28.30	21.10	3.5	26.90	20.60	4.0	
72 (22)	36.30	18.60	2.2	35.10	18.20	2.5	33.80	17.70	2.8	32.50	17.20	3.2	31.10	16.70	3.6	29.60	16.20	4.0	
57 (14)	30.90	30.20	2.2	30.00	29.30	2.5	29.10	28.40	2.8	28.20	27.50	3.2	27.10	26.50	3.6	26.00	25.40	4.0	
62 (17)	31.10	29.80	2.2	30.20	29.30	2.5	29.20	28.50	2.8	28.20	27.50	3.2	27.20	26.50	3.6	26.10	25.40	4.0	
63* (17)	31.50	23.90	2.2	30.50	23.50	2.5	29.40	23.00	2.8	28.20	22.50	3.2	26.90	22.00	3.6	25.60	21.40	4.0	
67 (19)	33.90	24.90	2.2	32.70	24.40	2.5	31.50	23.90	2.9	30.20	23.40	3.2	28.90	22.90	3.6	27.50	22.40	4.0	
72 (22)	37.10	19.80	2.3	35.80	19.30	2.6	34.50	18.90	2.9	33.10	18.40	3.3	31.70	17.90	3.7	30.10	17.30	4.1	
57 (14)	32.10	31.40	2.3	31.20	30.50	2.6	30.20	29.50	2.9	29.20	28.50	3.3	28.10	27.50	3.7	26.90	26.30	4.1	
62 (17)	32.20	31.40	2.3	31.30	30.50	2.6	30.30	29.60	2.9	29.30	28.60	3.3	28.20	27.50	3.7	27.00	26.30	4.1	
63* (17)	32.20	25.60	2.3	31.00	25.10	2.6	29.90	24.60	2.9	28.70	24.10	3.3	27.40	23.60	3.7	26.00	23.00	4.1	
67 (19)	34.50	26.70	2.3	33.30	26.20	2.6	32.00	25.70	3.0	30.70	25.20	3.3	29.40	24.70	3.7	27.90	24.10	4.1	
72 (22)	37.70	20.90	2.4	36.40	20.50	2.7	35.10	20.00	3.0	33.60	19.50	3.3	32.10	19.00	3.7	30.50	18.50	4.2	

50ZPA060 High Capacity

EVAPORATOR AIR		CONDENSER ENTERING AIR TEMPERATURES °F (°C)																	
		75 (24)			85 (29)			95 (35)			105 (41)			115 (46)			125 (52)		
		Capacity MBtuh		Total System KW	Capacity MBtuh		Total System KW	Capacity MBtuh		Total System KW	Capacity MBtuh		Total System KW	Capacity MBtuh		Total System KW	Capacity MBtuh		Total System KW
CFM / BF	EWB °F (°C)	Total	Sens	KW	Total	Sens	KW	Total	Sens	KW	Total	Sens	KW	Total	Sens	KW	Total	Sens	KW
		57 (14)	51.50		48.93	4.30		49.70	47.22		4.70	47.80		45.41	5.20		45.80	43.51	
62 (17)	52.10	47.93	4.30	49.90	46.91	4.70	47.80	45.41	5.20	45.90	43.61	5.70	43.80	41.61	6.30	41.70	39.60	6.90	
63* (17)	52.80	38.54	4.30	50.50	37.37	4.70	48.10	36.56	5.20	45.80	35.72	5.70	43.40	34.72	6.30	40.80	33.50	6.90	
67 (19)	56.70	40.26	4.40	54.10	38.95	4.80	51.50	38.11	5.30	49.00	37.24	5.80	46.30	36.11	6.30	43.60	35.00	6.90	
72 (22)	62.00	31.62	4.50	59.20	30.78	4.90	56.30	29.84	5.40	53.50	28.89	5.90	50.40	27.72	6.40	47.90	26.80	7.10	
57 (14)	52.70	50.07	4.40	50.70	48.17	4.80	48.70	46.27	5.30	46.70	44.37	5.80	44.60	42.37	6.40	42.40	40.20	7.00	
62 (17)	52.80	49.63	4.40	50.80	48.26	4.80	48.80	46.36	5.30	46.80	44.46	5.80	44.70	42.47	6.40	42.40	40.30	7.00	
63* (17)	53.40	40.05	4.40	51.00	38.76	4.80	48.60	37.91	5.30	46.20	36.96	5.80	43.70	35.83	6.40	41.20	34.90	7.00	
67 (19)	57.20	41.76	4.50	54.60	40.40	4.90	52.00	39.52	5.40	49.40	38.53	5.90	46.70	37.36	6.50	44.00	36.50	7.00	
72 (22)	62.60	32.55	4.60	59.70	31.64	5.00	56.80	30.67	5.50	53.90	29.65	6.00	50.60	28.34	6.50	48.10	27.70	7.10	
57 (14)	55.50	52.73	4.50	53.30	52.73	5.00	51.20	48.64	5.40	48.90	46.46	5.90	46.60	44.27	6.50	44.20	42.00	7.10	
62 (17)	55.50	52.73	4.50	53.40	52.73	5.00	51.20	48.64	5.40	49.00	46.55	5.90	46.70	44.37	6.50	44.30	42.00	7.10	
63* (17)	54.80	43.84	4.50	52.20	43.84	4.90	49.70	41.75	5.40	47.20	41.06	5.90	44.70	39.78	6.50	42.00	38.70	7.10	
67 (19)	58.60	45.71	4.60	55.90	45.71	5.00	53.10	44.07	5.50	50.40	42.84	6.00	47.60	41.89	6.50	44.70	40.60	7.10	
72 (22)	64.00	35.20	4.70	60.90	35.20	5.10	57.90	33.58	5.60	54.80	32.33	6.10	51.40	31.35	6.60	48.40	30.30	7.20	

See Legend and Notes on page 11.

COOLING CAPACITIES (CONT)

50ZPA060 Low Capacity

EVAPORATOR AIR		CONDENSER ENTERING AIR TEMPERATURES ° F (° C)																	
		75 (24)			85 (29)			95 (35)			105 (41)			115 (46)			125 (52)		
		CFM / BF	EWB ° F (° C)	Capacity MBtuh		Total System KW	Capacity MBtuh		Total System KW	Capacity MBtuh		Total System KW	Capacity MBtuh		Total System KW	Capacity MBtuh		Total System KW	
Total	Sens			Total	Sens		Total	Sens		Total	Sens		Total	Sens		Total	Sens		
1150 / 0.05	57 (14)	34.10	33.90	2.70	33.10	32.80	3.00	32.00	31.70	3.30	30.90	30.60	3.70	29.80	29.50	4.10	28.70	28.50	4.50
	62 (17)	35.10	32.30	2.60	33.80	31.70	2.90	32.40	31.00	3.20	31.10	30.40	3.60	29.80	29.60	4.00	28.70	28.50	4.50
	63* (17)	35.80	25.90	2.60	34.40	25.30	2.90	33.00	24.70	3.20	31.60	24.10	3.60	30.20	23.50	4.00	28.90	22.90	4.50
	67 (19)	38.70	27.00	2.60	37.20	26.40	2.90	35.70	25.80	3.20	34.20	25.20	3.60	32.70	24.60	4.00	31.10	24.00	4.50
	72 (22)	42.60	21.60	2.60	41.00	21.00	2.90	39.40	20.40	3.20	37.70	19.80	3.60	36.20	19.30	4.00	35.10	18.90	4.50
1300 / 0.06	57 (14)	35.70	35.40	2.70	34.50	34.30	3.00	33.40	33.10	3.30	32.20	31.90	3.70	31.00	30.80	4.10	29.90	29.60	4.60
	62 (17)	36.10	34.80	2.70	34.70	34.10	3.00	33.40	33.10	3.30	32.20	32.00	3.70	31.10	30.80	4.10	29.90	29.70	4.60
	63* (17)	36.60	27.70	2.70	35.20	27.10	3.00	33.70	26.50	3.30	32.30	25.80	3.70	30.80	25.20	4.10	29.40	24.60	4.50
	67 (19)	39.50	28.90	2.70	38.00	28.30	3.00	36.40	27.70	3.30	34.80	27.00	3.70	33.30	26.40	4.10	31.80	25.80	4.60
	72 (22)	43.40	22.80	2.70	41.70	22.20	3.00	40.10	21.60	3.30	38.10	20.90	3.70	36.70	20.40	4.10	35.30	19.90	4.60
1500 / 0.07	57 (14)	37.40	37.10	2.70	36.20	35.90	3.00	34.90	34.60	3.30	33.70	33.40	3.70	32.40	32.10	4.10	31.00	30.70	4.60
	62 (17)	37.50	37.20	2.80	36.20	36.00	3.10	35.00	34.70	3.40	33.70	33.70	3.70	32.40	32.20	4.20	31.40	31.20	4.60
	63* (17)	37.50	30.00	2.80	36.00	29.40	3.10	34.50	28.70	3.40	33.00	28.10	3.70	31.50	27.50	4.20	30.00	26.90	4.60
	67 (19)	40.40	31.40	2.80	38.80	30.80	3.10	37.20	30.10	3.40	35.50	29.50	3.80	33.90	28.80	4.20	32.10	28.10	4.60
	72 (22)	44.20	24.30	2.80	42.50	23.70	3.10	40.70	23.10	3.40	39.10	22.60	3.80	37.10	21.80	4.20	35.10	21.20	4.70

* At 75 ° F entering dry bulb – Tennessee Valley Authority (TVA) rating conditions; all others at 80 ° F dry bulb.

LEGEND

BF — Bypass Factor

Ewb — Entering Wet-Bulb

kW — Total Unit Power Input

SHC — Sensible Heat Capacity (1000 Btuh)

TC — Total Capacity (1000 Btuh) (net)

NOTES:

1. Direct interpolation is permissible. Do not extrapolate.
2. The following formulas may be used:

$$t_{db} = t_{edb} - \frac{\text{Sensible capacity (Btuh)}}{1.10 \times \text{cfm}}$$

$$t_{hwb} = t_{ewb} - \frac{\text{total capacity (Btuh)}}{4.5 \times \text{cfm}}$$

$$t_{hwb} = t_{ewb} - 4.5 \times \text{cfm}$$

Where: t_{hwb} = Enthalpy of air entering evaporator coils. The SHC is based on 80 ° F (26.7 ° C) edb temperature of air entering indoor coil. Below 80 ° F (26.7 ° C) edb, subtract (corr factor x cfm) from SHC. Above 80 ° F (26.7 ° C) edb, add (corr factor x cfm) to SHC.

Correction Factor = $1.10 \times (1 - BF) \times (edb - 80)$.

$$t_{wb} = \text{Wet-bulb temperature corresponding to enthalpy air leaving evaporator coil (} t_{hwb} \text{)}$$

Wet Coil Pressure Drop (IN. W.C.)

UNIT SIZE	STANDARD CFM (S.C.F.M.)														
	600	700	800	900	1000	1100	1200	1300	1400	1500	1600	1700	1800	1900	2000
024	0.027	0.034	0.040	0.047	0.053	—	—	—	—	—	—	—	—	—	—
030	—	0.036	0.042	0.050	0.055	0.063	0.072	0.081	—	—	—	—	—	—	—
036	—	—	—	0.050	0.055	0.063	0.072	0.081	0.090	0.097	—	—	—	—	—
042	—	—	—	—	0.042	0.049	0.052	0.059	0.065	0.071	0.078	0.085	0.091	—	—
049	—	—	—	—	—	—	0.072	0.081	0.090	0.097	0.108	0.120	0.129	0.139	—
048	—	—	—	—	—	—	0.072	0.081	0.090	0.097	0.108	0.120	0.129	0.139	—
060	—	—	—	—	—	—	—	—	—	0.071	0.078	0.085	0.091	0.098	0.114

Filter Pressure Drop (IN. W.C.)

UNIT SIZE	FILTER SIZE in. (mm)	CFM									
		500	600	700	800	900	1000	1100	1200	1300	
024-036	24 x 24 (609.6 x 609.6)	0.06	0.07	0.08	0.08	0.09	0.09	0.09	0.10	0.11	
042-060	30 x 30 (762 x 762)	—	—	—	—	—	—	—	—	0.08	

UNIT SIZE	FILTER SIZE in. (mm)	CFM									
		1400	1500	1600	1700	1800	1900	2000	2100	2200	2300
024-036	24 x 24 (609.6 x 609.6)	0.12	0.14	0.15	—	—	—	—	—	—	—
042-060	30 x 30 (762 x 762)	0.09	0.10	0.11	0.12	0.13	0.14	0.15	0.16	0.17	0.18

Accessory Electric Heat Pressure Drop (IN. W.C.)

HEATER kW	CFM									
	600	800	1000	1200	1400	1600	1800	2000	2200	
5-20	0.06	0.08	0.10	0.13	0.15	0.18	0.20	0.23	0.25	

50ZPA

Dry Coil Delivery*—Horizontal Discharge (Deduct 10% for 208-Volt Operation)

UNIT SIZE	SPEED TAP	AIR DELIVERY	208 VOLT HORIZONTAL DISCHARGE									
			External Static Pressure (IN. W.C.)									
			0.1	0.2	0.3	0.4	0.5	0.6	0.7	0.8	0.9	1.0
024	1	Watts	—	99	100	118	130	142	—	—	—	—
		CFM	—	848	793	757	698	632	—	—	—	—
	2	Watts	—	—	—	—	—	222	233	244	257	260
		CFM	—	—	—	—	—	970	918	861	795	729
030	2	Watts	—	155	146	157	170	—	—	—	—	—
		CFM	—	1108	995	951	884	—	—	—	—	—
	3	Watts	—	—	—	—	—	261	275	286	291	315
		CFM	—	—	—	—	—	1117	1053	1014	980	877
036	1	Watts	180	166	179	191	204	216	—	—	—	—
		CFM	1344	1215	1172	1136	1095	1051	—	—	—	—
	2	Watts	—	—	—	261	276	290	301	316	329	342
		CFM	—	—	—	1343	1304	1272	1234	1190	1148	1100
042	3	Watts	269	283	305	321	336	349	360	—	—	—
		CFM	1440	1404	1369	1333	1301	1273	1239	—	—	—
	4	Watts	—	—	418	432	450	465	480	490	503	518
		CFM	—	—	1572	1543	1504	1475	1441	1418	1380	1332
049	1	Watts	—	204	209	216	229	236	249	—	—	—
		CFM	—	1129	1087	1027	994	932	881	—	—	—
	2	Watts	—	—	233	245	254	266	276	289	—	—
		CFM	—	—	1164	1122	1066	1025	954	906	—	—
	3	Watts	386	398	409	418	425	435	438	441	451	—
		CFM	1680	1652	1625	1583	1555	1515	1477	1444	1403	—
	4	Watts	—	440	448	457	462	469	477	480	485	486
		CFM	—	1745	1717	1684	1651	1612	1573	1537	1508	1470
048	1	Watts	—	204	209	216	229	236	249	—	—	—
		CFM	—	1129	1087	1027	994	932	881	—	—	—
	2	Watts	—	—	233	245	254	266	276	289	—	—
		CFM	—	—	1164	1122	1066	1025	954	906	—	—
	3	Watts	386	398	409	418	425	435	438	441	451	—
		CFM	1680	1652	1625	1583	1555	1515	1477	1444	1403	—
	4	Watts	—	440	448	457	462	469	477	480	485	486
		CFM	—	1745	1717	1684	1651	1612	1573	1537	1508	1470
060	1	Watts	224	235	251	266	277	291	298	—	—	—
		CFM	1334	1288	1259	1224	1181	1157	1117	—	—	—
	2	Watts	—	—	286	301	311	325	333	344	370	—
		CFM	—	—	1333	1296	1261	1232	1199	1170	1062	—
	3	Watts	608	626	643	660	668	685	697	—	—	—
		CFM	1931	1900	1878	1844	1817	1789	1755	—	—	—
	4	Watts	737	755	770	787	799	817	826	812	782	—
		CFM	2093	2061	2028	2001	1971	1934	1899	1850	1757	—

*Air delivery values are based on operating voltage of 230v or dry coil, without filter or electric heater. Deduct wet coil, filter, and electric heater pressure drops to obtain external static pressure available for ducting.

NOTES:

1. Do not operate the unit at a cooling airflow that is less than 350 cfm for each 12,000 Btuh of rated cooling capacity. Evaporator coil frosting may occur at airflows below this point.
2. Dashes indicate portions of the table that are beyond the blower motor capacity or are not recommended.

50ZPA

TYPICAL WIRING SCHEMATIC—208/230-1-60 50ZPA024-042 AND 049

50ZPA

**SCHEMATIC
208/230-1-60**

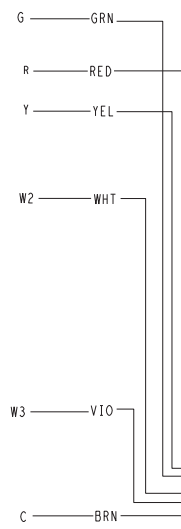
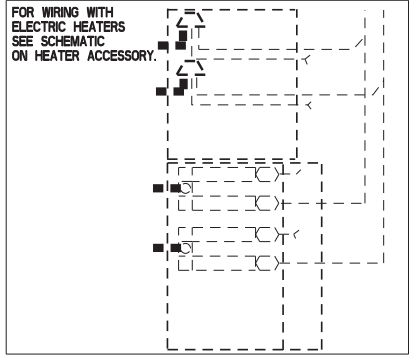
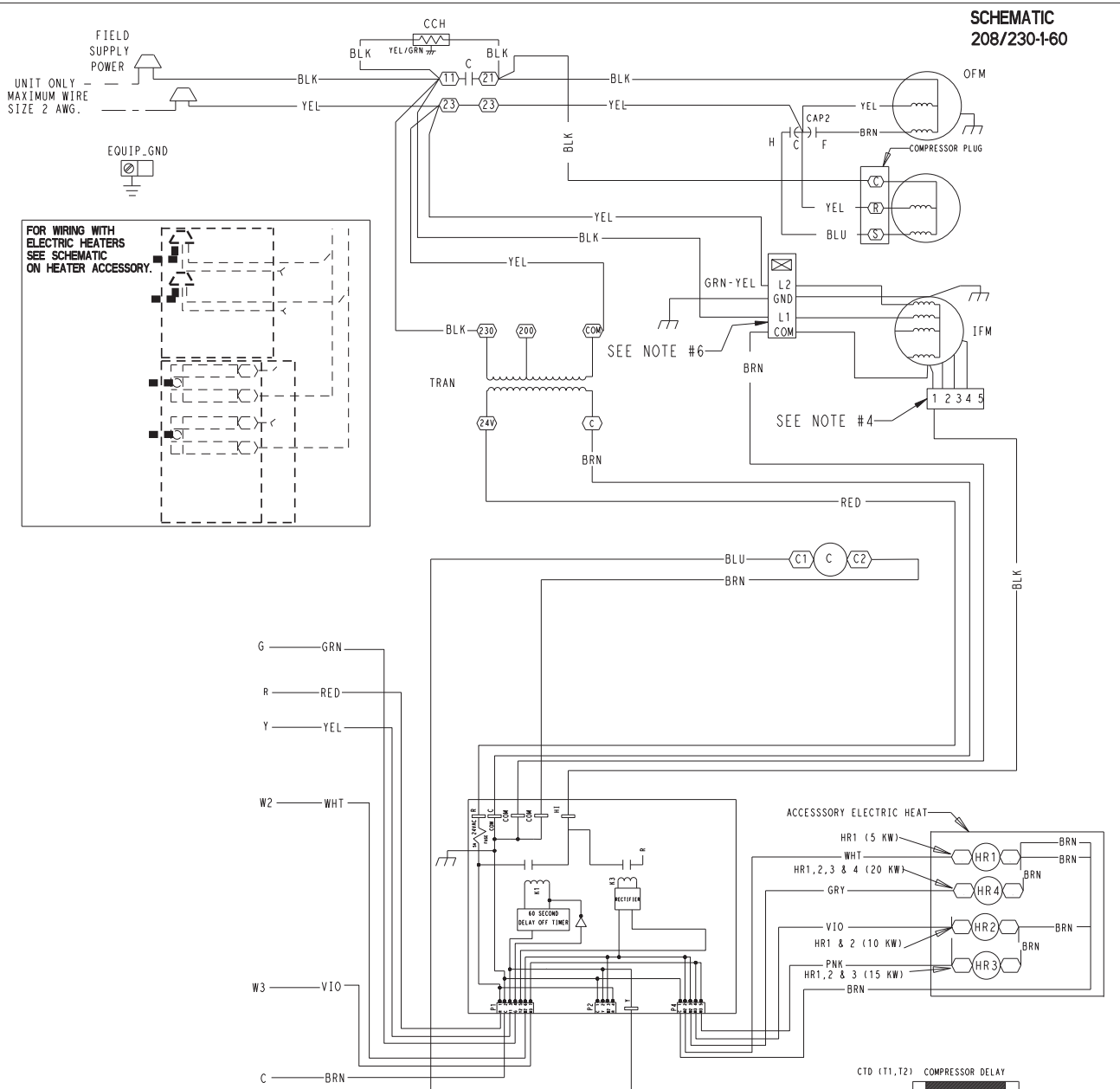

LEGEND

- ◻ FIELD SPLICE
 - TERMINAL (MARKED) ENERGIZED
 - TERMINAL (UNMARKED)
 - SPLICE
 - SPLICE (MARKED)
 - FACTORY WIRING
 - - - FIELD CONTROL WIRING
 - - - FIELD POWER WIRING
 - - - ACCESSORY OR OPTIONAL WIRING
 - TO INDICATE COMMON POTENTIAL ONLY: NOT TO REPRESENT WIRING
- | | |
|------|-----------------------|
| CAP | CAPACITOR |
| CCH | CRANK CASE HEATER |
| COMP | COMPRESSOR MOTOR |
| CTD | COMPRESSOR TIME DELAY |
| FCB | FAN CONTROL BOARD |
| GND | GROUND |
| HR | HEATER RELAY |
| IFM | INDOOR FAN MOTOR |
| OFM | OUTDOOR FAN MOTOR |
| TRAN | TRANSFORMER |

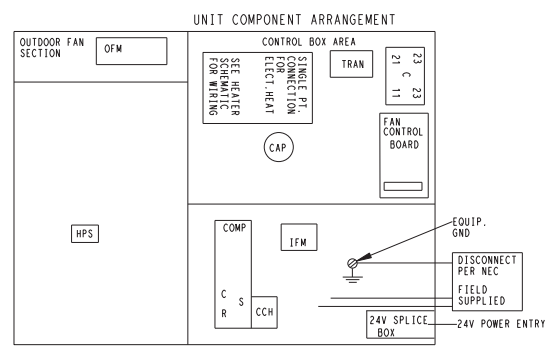
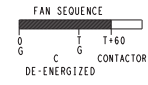
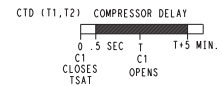

- NOTES:**
- IF ANY OF THE ORIGINAL WIRES FURNISHED ARE REPLACED, IT MUST BE REPLACED WITH TYPE 90°C WIRE OR IT'S EQUIVALENT.
 - SEE PRICE PAGES FOR THERMOSTAT AND SUB-BASES.
 - USE 75th COPPER CONDUCTORS FOR FIELD INSTALLATION.
 - FACTORY WIRING FOR SPEED SELECTOR PLUG:
024 = 1
030 = 2
036 = 1
042 = 3
048 = 3
 - RELOCATION OF SPEED TAPS MAY BE REQUIRED WHEN USING FIELD INSTALLED ELECTRIC HEATERS. CONSULT INSTALLATION INSTRUCTIONS TO DETERMINE CORRECT SPEED TAP SETTING.
 - DO NOT DISCONNECT PLUG UNDER LOAD.**

50ZP500600 10.0

A07912

TYPICAL WIRING SCHEMATIC—208/230-1-60 50ZPA048 AND 060

**SCHEMATIC
208/230-1-60**

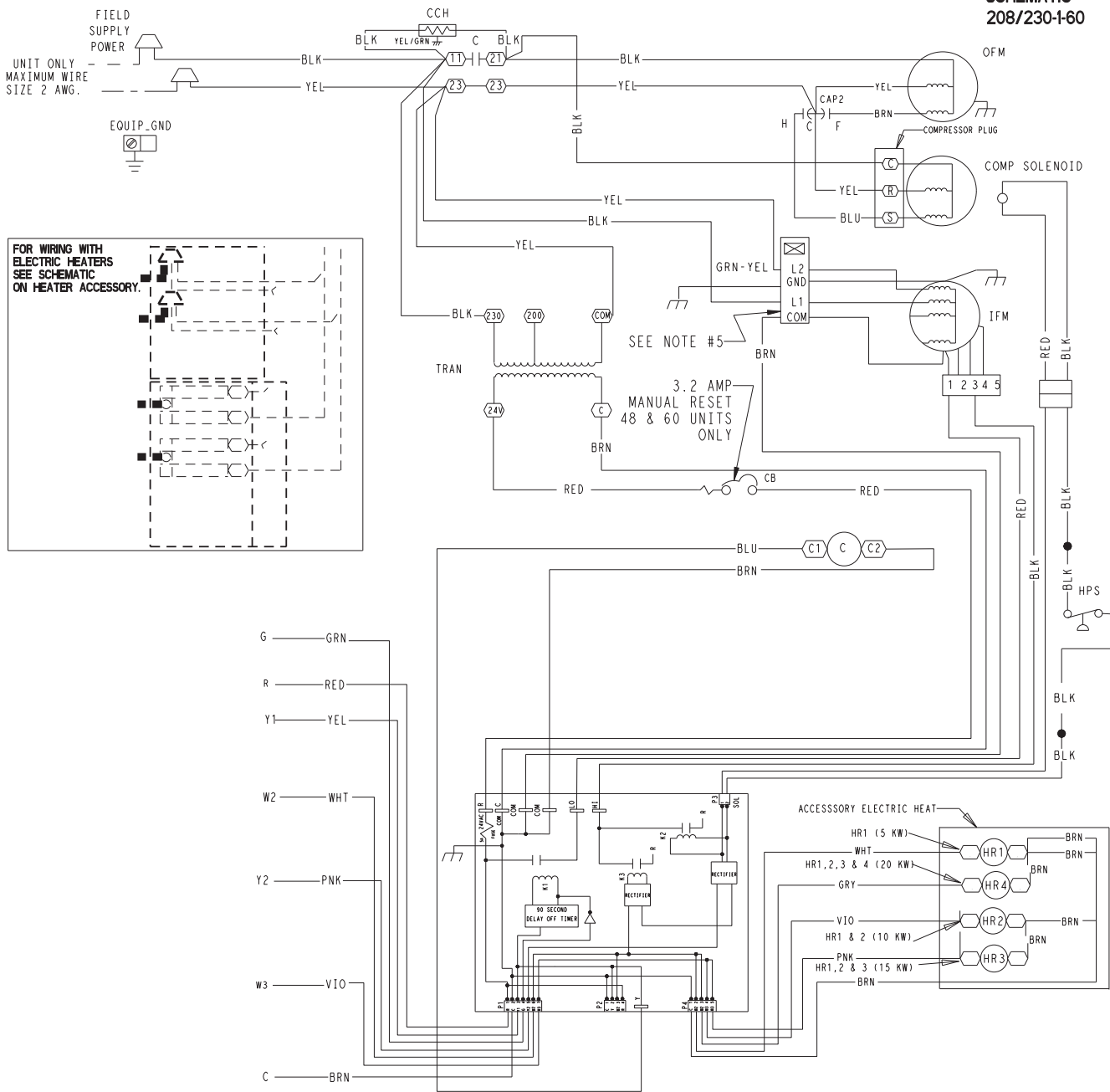

50ZPA

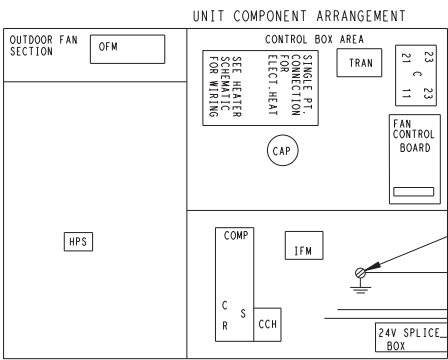

- NOTES:**
1. IF ANY OF THE ORIGINAL WIRES FURNISHED ARE REPLACED, IT MUST BE REPLACED WITH TYPE 90 DEGREE C WIRE OR IT'S EQUIVALENT.
 2. SEE PRICE PAGES FOR THERMOSTAT AND SUBBASES.
 3. USE 75 DEGREE COPPER CONDUCTORS FOR FIELD INSTALLATION.
 4. RELOCATION OF SPEED TAPS MAY BE REQUIRED WHEN USING FIELD INSTALLED ELECTRIC HEATERS. CONSULT INSTALLATION INSTRUCTIONS TO DETERMINE CORRECT SPEED TAP SETTING.
 5. *DO NOT DISCONNECT PLUG WHILE UNDER LOAD*.

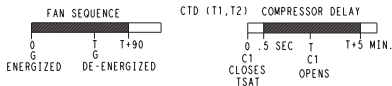

50ZP500587 10.0

A07896

TYPICAL THREE-PHASE UNIT ELECTRICAL DIAGRAM (SIZES 030-042 AND 049)

**SCHEMATIC
208/230-3-60**

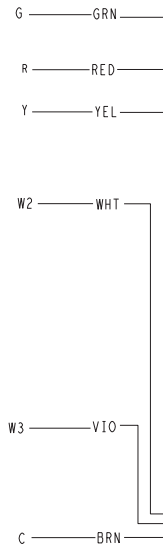
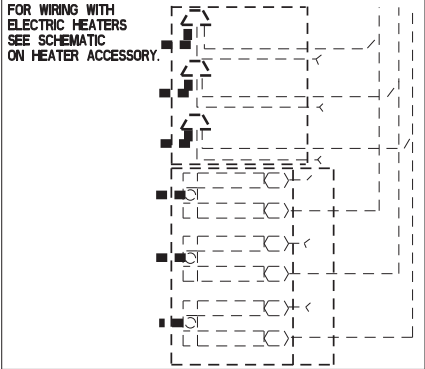
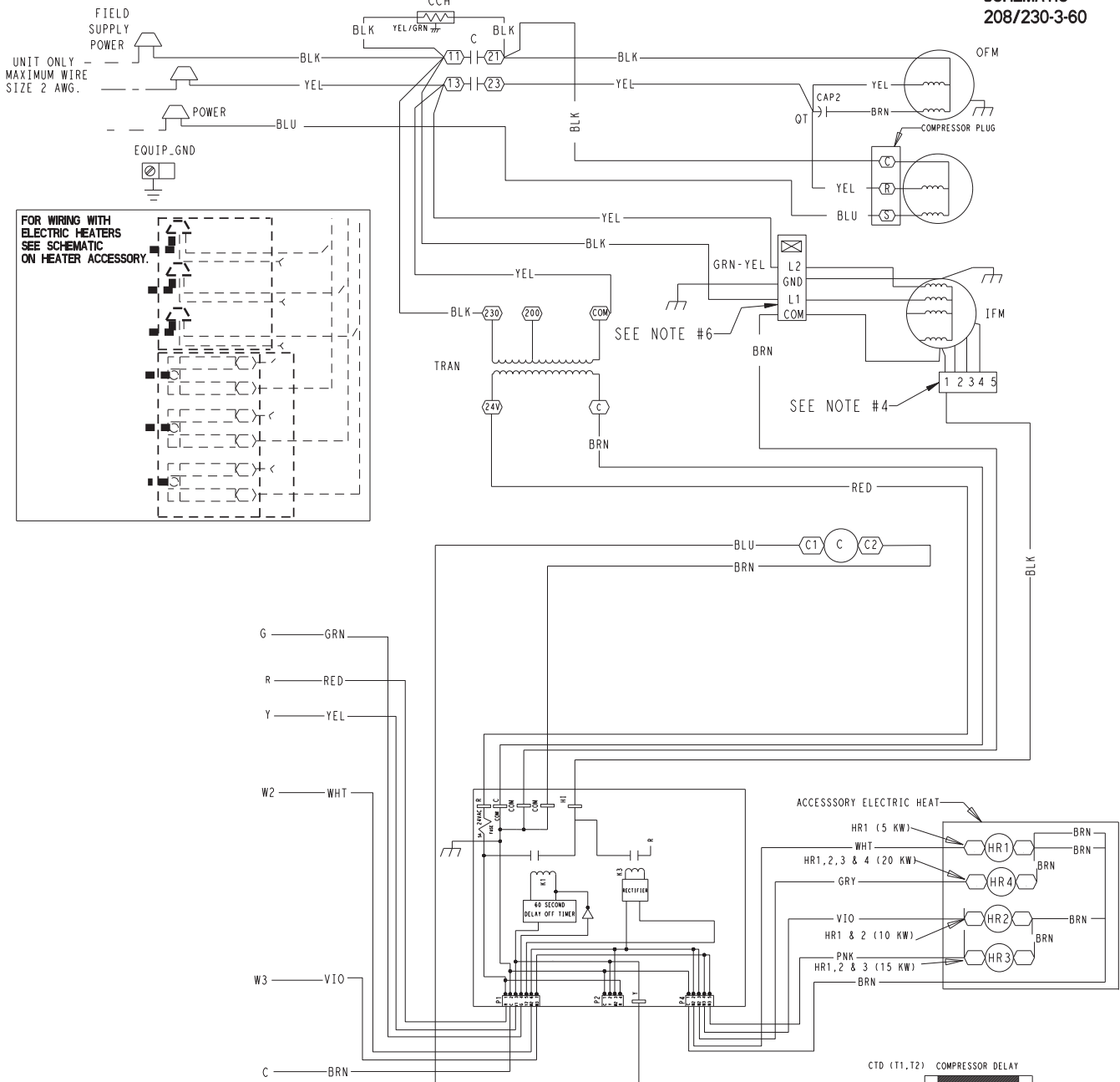

LEGEND

- FIELD SPLICE
 - TERMINAL (MARKED) ENERGIZED
 - TERMINAL (UNMARKED)
 - SPLICE
 - SPLICE (MARKED)
 - FACTORY WIRING
 - - - FIELD CONTROL WIRING
 - - - FIELD POWER WIRING
 - - - ACCESSORY OR OPTIONAL WIRING
 - - - TO INDICATE COMMON POTENTIAL ONLY; NOT TO REPRESENT WIRING
- | | |
|------|-----------------------|
| CAP | CAPACITOR |
| CCH | CRANK CASE HEATER |
| COMP | COMPRESSOR MOTOR |
| CTD | COMPRESSOR TIME DELAY |
| FCB | FAN CONTROL BOARD |
| GND | GROUND |
| HR | HEATER RELAY |
| IFM | INDOOR FAN MOTOR |
| OFM | OUTDOOR FAN MOTOR |
| TRAN | TRANSFORMER |

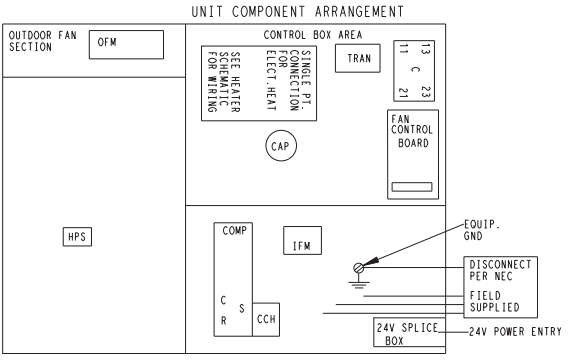
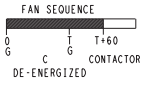
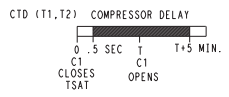

- NOTES:**
- IF ANY OF THE ORIGINAL WIRES FURNISHED ARE REPLACED, IT MUST BE REPLACED WITH TYPE 90°C WIRE OR IT'S EQUIVALENT.
 - SEE PRICE PAGES FOR THERMOSTAT AND SUB-BASES.
 - USE 75° COPPER CONDUCTORS FOR FIELD INSTALLATION.
 - FACTORY WIRING FOR SPEED SELECTOR PLUG:
 024 = 1
 030 = 2
 036 = 1
 042 = 3
 049 = 3
 - RELOCATION OF SPEED TAPS MAY BE REQUIRED WHEN USING FIELD INSTALLED ELECTRIC HEATERS. CONSULT INSTALLATION INSTRUCTIONS TO DETERMINE CORRECT SPEED TAP SETTING.
 - DO NOT DISCONNECT PLUG UNDER LOAD.

50ZP500637 5.0

50ZPA

TYPICAL THREE-PHASE UNIT ELECTRICAL DIAGRAM (SIZES 048 AND 060)

**SCHEMATIC
208/230-3-60**

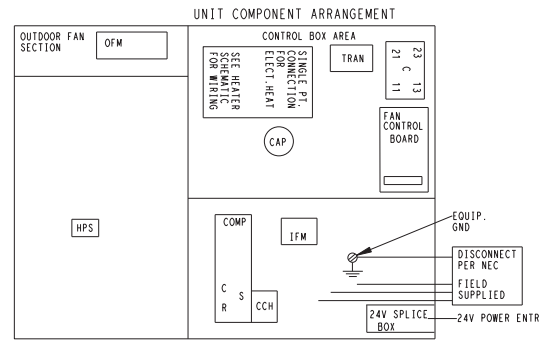
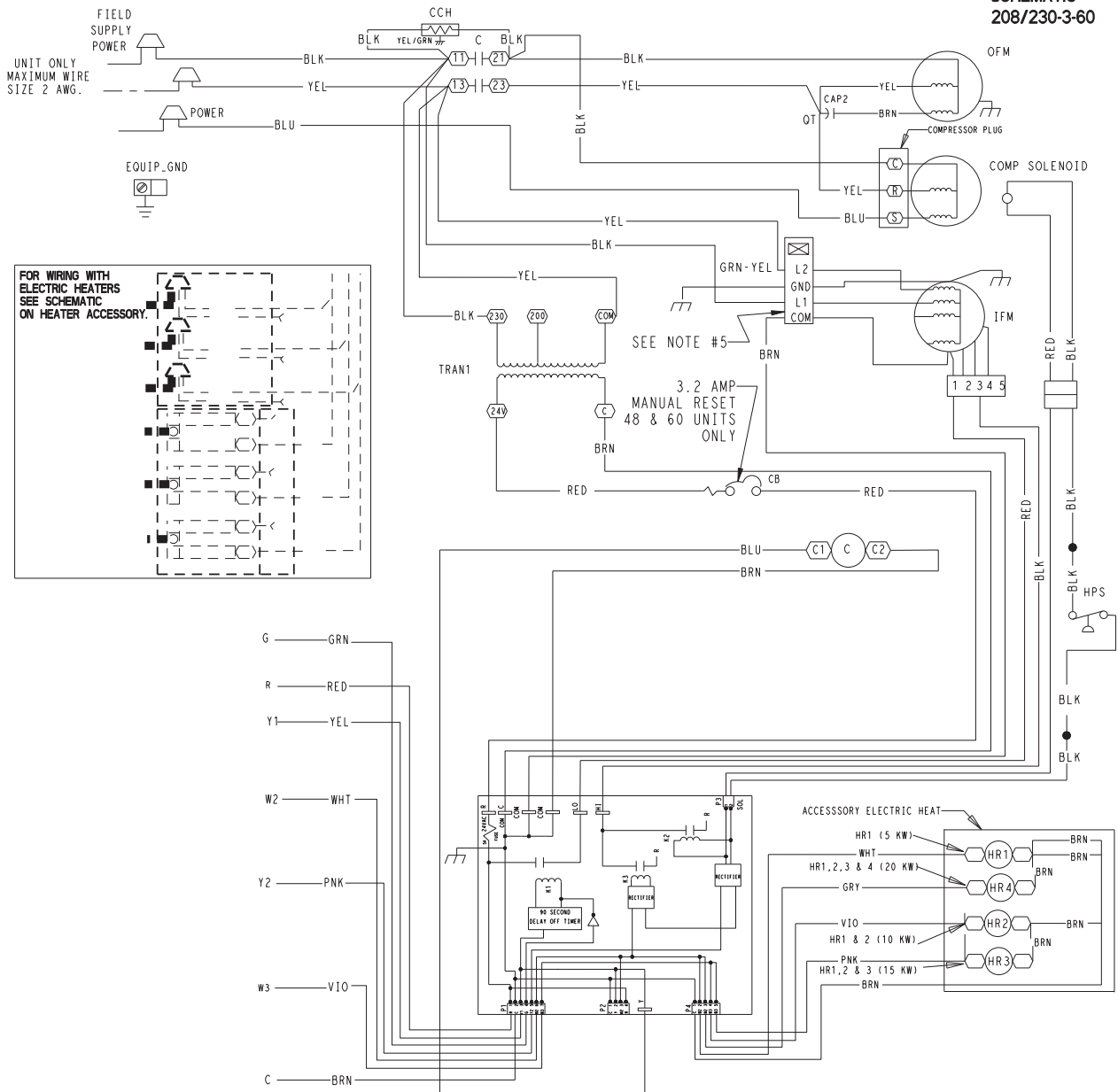

LEGEND

- △ FIELD SPLICE
- TERMINAL (MARKED)
- TERMINAL (UNMARKED)
- SPLICE (MARKED)
- FACTORY WIRING
- - - FIELD POWER WIRING
- · - · - FIELD OR OPTIONAL WIRING
- · - · - ACCESSORY OR OPTIONAL WIRING
- · - · - TO INDICATE COMMON POTENTIAL ONLY
- · - · - NOT TO REPRESENT WIRING
- C CONTACTOR
- CAP CAPACITOR
- CCH CRANK CASE HEATER
- COMP COMPRESSOR MOTOR
- CTD COMPRESSOR TIME DELAY
- FCB FAN CONTROL BOARD
- GND GROUND
- HR HEATER RELAY
- IFM INDOOR FAN MOTOR
- HPS LOW PRESSURE SWITCH
- OFM OUTDOOR FAN MOTOR
- RVS REVERSING VALVE SOLENOID
- TRAN TRANSFORMER

- NOTES:**
- IF ANY OF THE ORIGINAL WIRES FURNISHED ARE REPLACED, IT MUST BE REPLACED WITH TYPE 90 DEGREE C WIRE OR IT'S EQUIVALENT.
 - SEE PRICE PAGES FOR THERMOSTAT AND SUBBASES.
 - USE 75 DEGREE COPPER CONDUCTORS FOR FIELD INSTALLATION.
 - RELOCATION OF SPEED TAPS MAY BE REQUIRED WHEN USING FIELD INSTALLED ELECTRIC HEATERS. CONSULT INSTALLATION INSTRUCTIONS TO DETERMINE CORRECT SPEED TAP SETTING.
 - DO NOT DISCONNECT PLUG WHILE UNDER LOAD.

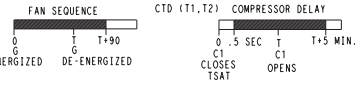

50ZP500638 3.0

50ZPA

TYPICAL FIELD WIRING

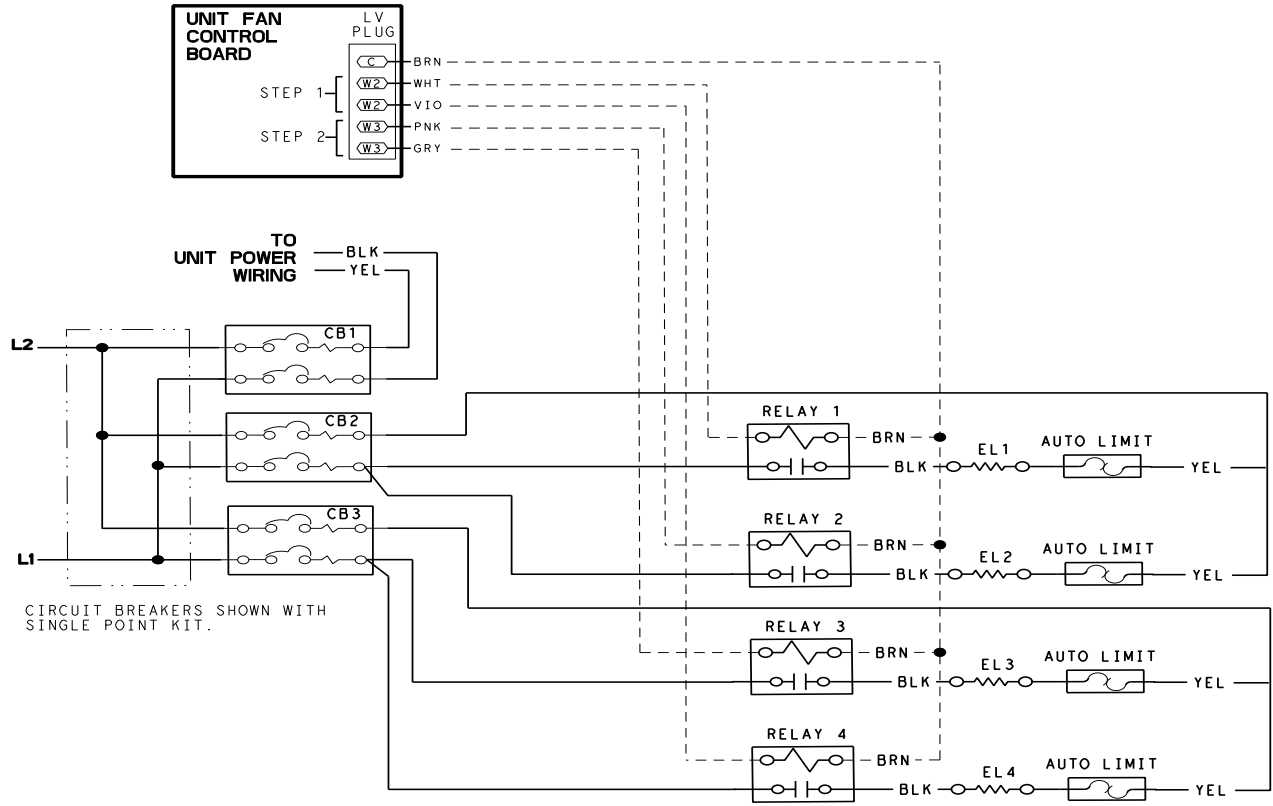

Single-Phase Accessory Electric Heater Wiring

A05209

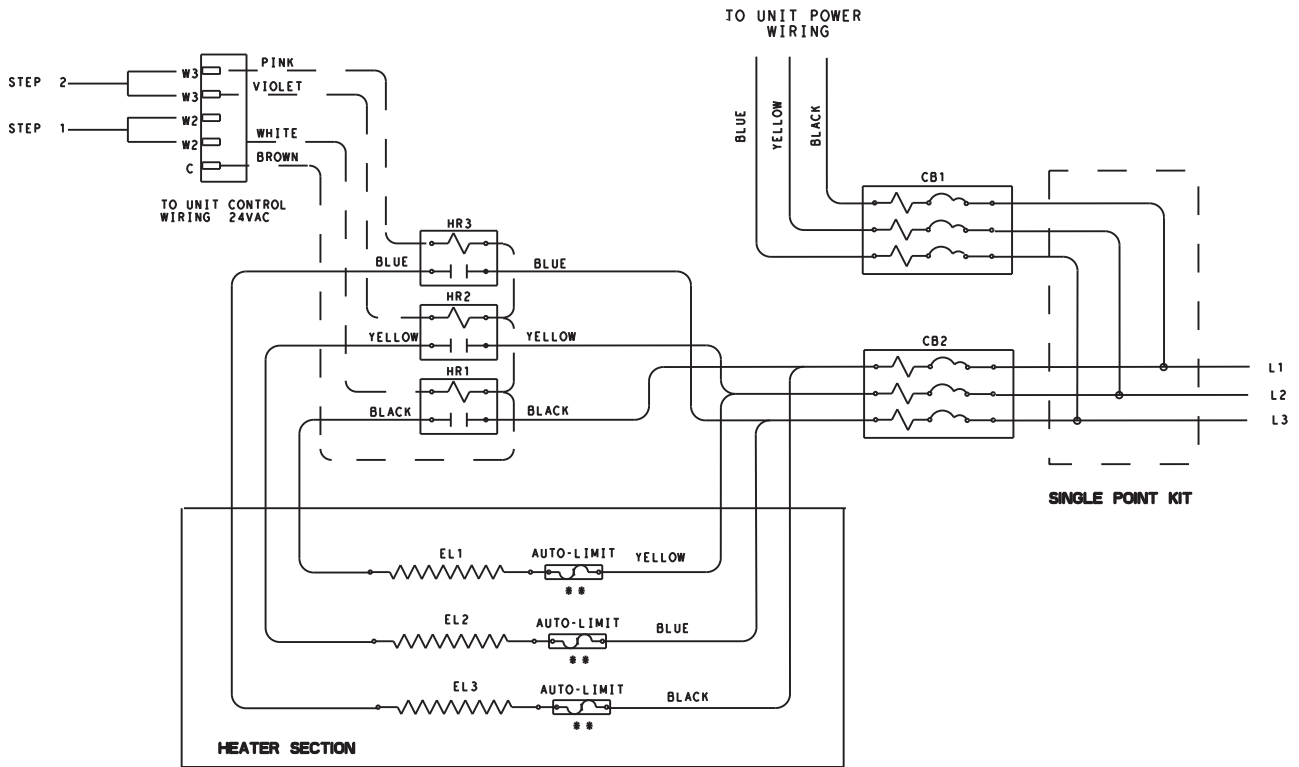

Three-Phase Accessory Electric Heater Wiring

A06327

50ZPA

Electrical Data

UNIT	NOMINAL V-PH-HZ	VOLTAGE RANGE		COMPRESSOR		OFM	IFM	ELECTRIC HEAT		POWER SUPPLY	
		MIN	MAX	RLA	LRA	FLA	FLA	NOMINAL kW *	FLA	MCA	MOCP **
024	208/230-1-60	187	253	10.9	54.0	0.9	4.1	-/-	-/-	18.6/18.6	25/25
								3.8/5	18.0/20.8	27.6/31.1	30/35
								5.6/7.5	27.0/31.3	38.9/44.3	40/45
								7.5/10	36.1/41.7	50.3/57.3	60/60
								-/-	-/-	21.8/21.8	30/30
030	208/230-1-60	187	253	13.5	72.5	0.9	4.1	3.8/5	18.0/20.8	27.6/31.1	30/35
								5.6/7.5	27.0/31.3	38.9/44.3	40/45
								7.5/10	36.1/41.7	50.3/57.3	60/60
								11.3/15	54.1/62.5	72.8/83.3	80/90
								-/-	-/-	16.3/16.3	25/25
030	208/230-3-60	187	253	9.0	63.0	0.9	4.1	3.8/5	10.4/12.0	18.1/20.1	25/25
								7.5/10	20.8/24.1	31.1/35.3	35/40
								11.3/15	31.4/36.1	44.4/50.3	45/60
								-/-	-/-	27.4/27.4	40/40
								3.8/5	18.0/20.8	30.0/33.5	40/40
036	208/230-1-60	187	253	16.0	88.0	1.4	6.0	5.6/7.5	27.0/31.3	41.3/46.6	45/50
								7.5/10	36.1/41.7	52.6/59.6	60/60
								11.3/15	54.1/62.5	75.1/85.6	80/90
								15.0/20.0	72.1/83.3	97.6/111.6	100/125
								-/-	-/-	20.8/20.8	30/30
								3.8/5	10.4/12.0	20.5/22.5	30/30
036	208/230-3-60	187	253	10.7	77.0	1.4	6.0	7.5/10	20.8/24.1	33.5/37.6	35/40
								11.3/15	31.4/36.1	46.8/52.6	50/60
								15.0/20.0	41.4/47.9	59.3/67.4	60/70
								-/-	-/-	29.8/29.8	40/40
								3.8/5	18.0/20.8	30.0/33.5	40/40
042	208/230-1-60	187	253	17.9	104.0	1.4	6.0	5.6/7.5	27.0/31.3	41.3/46.6	45/50
								7.5/10	36.1/41.7	52.6/59.6	60/60
								11.3/15	54.1/62.5	75.1/85.6	80/90
								15.0/20.0	72.1/83.3	97.6/111.6	100/125
								-/-	-/-	23.0/23.0	35/35
								3.8/5	10.4/12.0	23.0/23.0	35/35
042	208/230-3-60	187	253	12.4	88.0	1.4	6.0	7.5/10	20.8/24.1	33.5/37.6	35/40
								11.3/15	31.4/36.1	46.8/52.6	50/60
								15.0/20.0	41.4/47.9	59.3/67.4	60/70
								-/-	-/-	33.0/33.0	50/50
								3.8/5	18.1/20.8	33.0/33.5	50/50
049	208/230-1-60	187	253	19.2	97.0	1.4	7.6	5.6/7.5	27.1/31.3	43.3/48.6	50/50
								7.5/10	36.1/41.7	54.6/61.6	60/70
								11.3/15	54.2/62.5	77.2/87.6	80/90
								15.0/20.0	72.2/83.3	99.8/113.7	100/125
								-/-	-/-	24.9/24.9	35/35
049	208/230-3-60	187	253	12.7	88.0	1.4	7.6	3.8/5	10.4/12.0	24.9/24.9	35/35
								7.5/10	20.8/24.1	35.6/39.6	40/40
								11.3/15	31.3/36.1	48.6/54.6	50/60
								14.9/19.9	41.5/47.9	61.4/69.3	70/70
								-/-	-/-	35.9/35.9	50/50
048	208/230-1-60	187	253	21.5	116.0	1.4	7.6	3.8/5	18.0/20.8	35.9/35.9	50/50
								5.6/7.5	27.0/31.3	43.3/48.6	50/50
								7.5/10	36.1/41.7	54.6/61.6	60/70
								11.3/15	54.1/62.5	77.1/87.6	80/90
								15.0/20.0	72.1/83.3	99.6/113.6	100/125
048	208/230-3-60	187	253	13.3	91.0	1.4	7.6	-/-	-/-	25.6/25.6	35/35
								3.8/5	10.4/12.0	25.6/25.6	35/35
								7.5/10	20.8/24.1	35.5/39.6	40/40
								11.3/15	31.4/36.1	48.8/54.6	50/60
								15.0/20.0	41.4/47.9	61.3/69.4	70/70
060	208/230-1-60	187	253	24.1	118.0	3.0	7.6	-/-	-/-	40.7/40.7	60/60
								3.8/5	18.0/20.8	40.7/40.7	60/60
								5.6/7.5	27.0/31.3	43.3/48.6	60/60
								7.5/10	36.1/41.7	54.6/61.6	60/70
								11.3/15	54.1/62.5	77.1/87.6	80/90
								15.0/20.0	72.1/83.3	99.6/113.6	100/125
060	208/230-3-60	187	253	17.0	123.0	3.0	7.6	-/-	-/-	31.9/31.9	45/45
								3.8/5	10.4/12.0	31.9/31.9	45/45
								7.5/10	20.8/24.1	35.5/39.6	45/45
								11.3/15	31.4/36.1	48.8/54.6	50/60
								15.0/20.0	41.4/47.9	61.3/69.4	70/70

* kW @ 208/240

** Circuit breaker

50ZPA

- LEGEND
- FLA — Full Load Amps
 - LFA — Locked Rotor Amps
 - MCA — Minimum Circuit Amps
 - MOCP — Maximum Overcurrent Protection
 - RLA — Rated Load Amps



NOTES:

1. In compliance with NEC (National Electrical Code) requirements for multimotor and combination load equipment (refer to NEC Articles 430 and 440), the overcurrent protective device for the unit shall be Power Supply fuse. The CGA (Canadian Gas Association) units may be fuse or circuit breaker.
2. Minimum wire size is based on 60°C copper wire. If other than 60°C wire is used, or if length exceeds wire length in table, determine size from NEC.
3. Unbalanced 3-Phase Supply Voltage
Never operate a motor where a phase imbalance in supply voltage is greater than 2%. Use the following formula to determine the percentage of voltage imbalance.

$$\% \text{ Voltage imbalance} = 100 \times \frac{\text{max voltage deviation from average voltage}}{\text{average voltage}}$$

- * Heater capacity (kW) based on heater voltage of 208v & 240v. If power distribution voltage to unit varies from rated heater voltage, heater kW will vary accordingly.

EXAMPLE: Supply voltage is 230-3-60.

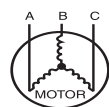

$$\begin{aligned} AB &= 228 \text{ v} \\ BC &= 231 \text{ v} \\ AC &= 227 \text{ v} \\ \text{Average Voltage} &= \frac{228 + 231 + 227}{3} \\ &= \frac{686}{3} \\ &= 229 \end{aligned}$$

Determine maximum deviation from average voltage.

- (AB) 229 - 228 = 1 v
- (BC) 231 - 229 = 2 v
- (AC) 229 - 227 = 2 v

Maximum deviation is 2 v.

Determine percent of voltage imbalance.

$$\% \text{ Voltage Imbalance} = 100 \times \frac{2}{229} = 0.8\%$$

This amount of phase imbalance is satisfactory as it is below the maximum allowable 2%.

IMPORTANT: If the supply voltage phase imbalance is more than 2%, contact your local electric utility company immediately.

50ZPA

OPERATING SEQUENCE

Cooling Operation (024 - 042 and 049)

With a call for cooling (Y/Y2), the indoor fan energizes immediately whereas the contactor energizes after a 5 minute time delay (in case of an initial start up) starting the compressor and the outdoor fan motor. When the cooling demand is met, Y/Y2 de-energizes, shutting the compressor, indoor fan and the outdoor fan.

Cooling Operation (048 and 060)

These units utilize a 2-stage indoor thermostat. With a first stage call for cooling (Y1), the indoor fan (low stage) energizes immediately where as the contactor energizes after a 5 minute time delay (in case of an initial start up) starting the compressor (low stage) and the outdoor fan motor. If the low stage operation cannot satisfy the cooling demand, the second stage cooling (Y2) energizes switching the compressor into high stage cooling through energizing an internal solenoid valve inside the scroll compressor and switching the indoor fan into high stage. When second stage cooling is satisfied, Y2 de-energizes switching the compressor and the indoor fan into low stage cooling. When the low stage cooling demand is met, Y1 de-energizes shutting the compressor, indoor fan and the outdoor fan.

Heating Operation (024 - 042 and 049)

With a call for heating (W2), the auxiliary or electric heat energizes along with the indoor blower. In case of staged heating, W3 is energized if the demand is not met. The highest airflow selected is run while the electric heat is in operation. When heating demand is met, W3 and W2 sequentially de-energize shutting the indoor fan and the electric heater.

Heating Operation (048 and 060)

With a call for heating (W2), the auxiliary electric heater is energized along with the indoor blower. If the demand is not met, W3 is energized in case of staged heating. When heating demand is satisfied, W3 and W2 sequentially de-energize along with the indoor fan blower.

Continuous Fan

With the continuous indoor fan option selected on the thermostat, G is continuously energized. In case of 024 - 042 and 049 units, the selected airflow setting is provided. In case of 048 and 060 units, the system runs low stage (Y1) airflow for continuous fan operation.

TYPICAL INSTALLATION

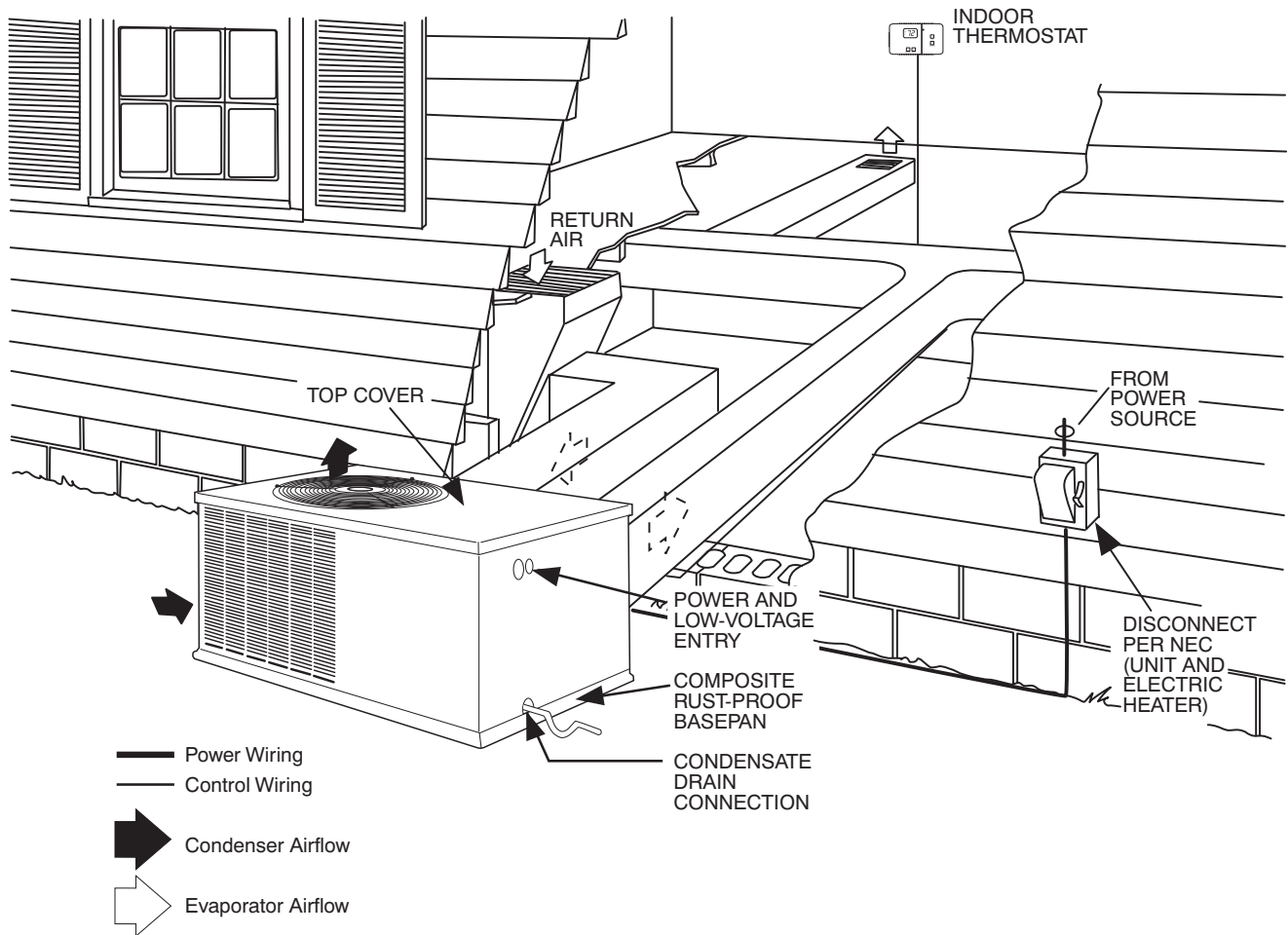

50ZPA

A08207

APPLICATION DATA

Condensate trap — A 2-in. (51 mm) condensate trap must be field supplied.

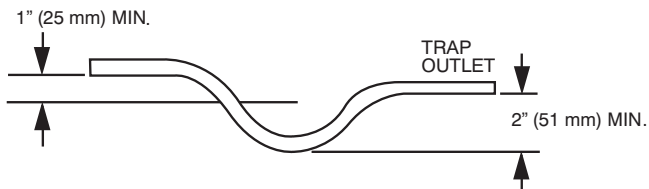

A08001

Maximum cooling airflow — To minimize the possibility of condensate blow-off from the evaporator, airflow through the units should not exceed 450 cfm/ton.

Minimum cooling airflow — The minimum cooling airflow is 350 cfm/ton.

Minimum cooling operating outdoor air temperature — All standard units have a minimum ambient operating temperature of 40°F (4.4°C). With accessory low ambient temperature kit, units can operate at temperatures down to 0°F (-17.8°C).

Maximum operating outdoor air temperature — Maximum outdoor operating air temperature for cooling is 125°F (51.7°C).

ENGINEERS' SPECIFICATION GUIDE

GENERAL

Furnish and install outdoor package, electrically controlled, air conditioner utilizing a reciprocating compressor for cooling duty. Unit shall discharge supply air horizontally or vertically as shown on contract drawings.

Nominal unit electrical characteristics shall be _____ v, _____ ph, 60 Hz. The unit shall be capable of satisfactory operation within voltage limits of _____ v to _____ v. Unit power wiring shall enter unit cabinet at a single location.

Separate power supply shall not be required for electric heat.

COOLING CAPACITY

Total cooling capacity of the unit shall be _____ Btuh or greater, and sensible capacity shall be _____ Btuh or greater at conditions of _____ cfm indoor air entering unit at _____ F dry bulb, _____ F wet bulb and outdoor entering air of _____ F dry bulb. Total design conditions shall be a minimum of _____ Btuh/Watt. The unit shall be capable of cooling operation down to 40°F (4.4°C) as shipped from the factory.

CABINET

Unit cabinet shall be constructed of phosphated, bonderized, zinc-coated, prepainted steel. Basepan shall be made of a single-piece non-corrosive, composite material.

Evaporator-fan compartment interior cabinet surfaces shall be insulated with a minimum 1/2-in. (12.7 mm) thick, flexible fiberglass insulation, coated on the air side with aluminum foil.

Cabinet panels shall be easily removable for servicing.

Outdoor coil shall be protected by metal louvered panels.

COMPRESSOR

Compressor shall be fully hermetic type with internal and external vibration isolation.

COMPRESSOR ROTATION

On 3-phase units it is important to be certain compressor is rotating in the proper direction. To determine whether or not compressor is rotating in the proper direction:

1. Connect service gauges to suction and discharge pressure fittings.
2. Energize the compressor.
3. The suction pressure should drop and the discharge pressure should rise, as is normal on any start-up.

If the suction pressure does not drop and the discharge pressure does not rise to normal levels:

1. Turn off power to the unit and tag disconnect.
2. Reverse any two of the unit power leads.
3. Turn on power to the unit.

The suction and discharge pressure levels should now move to their normal start-up levels.

NOTE: When the compressor is rotating in the wrong direction, the unit makes an elevated level of noise and does not provide cooling.

CONDENSER SECTION

Condenser fan shall be of the direct-driven propeller type with aluminum blades, riveted to corrosion-resistant steel spiders, and shall be dynamically balanced and discharge air horizontally or vertically upwards.

Condenser coils shall have aluminum-plate fins mechanically bonded to seamless copper tubes with all joints brazed.

Tube sheet openings shall be belled to prevent tube wear.

EVAPORATOR SECTION

Fan shall be multi-speed with direct drive motor as shown on the equipment drawings.

Fan wheel shall be made from steel, be double-inlet type with forward-curved blades with a corrosion-resistant finish and dynamically balanced.

Evaporator coils shall have aluminum-plate fins mechanically bonded to seamless copper tubes with all joints brazed.

Tube sheet openings shall be belled to prevent tube wear.

MOTORS

Compressor motors shall be of the refrigerant cooled type with line break thermal and current overload protection.

All fan motors shall have permanently lubricated bearings, and inherent automatic reset thermal overload protection.

Condenser fan motor shall be open drip-proof.

REFRIGERANT SYSTEM

Refrigerant system shall include fixed orifice or TXV metering system.

CONTROLS

Unit shall be complete with self-contained low voltage control circuit.

APPROVALS

Unit shall be UL listed as a total package for safety requirements. All wiring shall be in accordance with NEC.

Unit shall be rated in accordance with ARI Standards 210/240.

Cabinet insulation shall conform to ASHRAE Standard 62.2

Insulation and adhesive shall meet NFPA 90A requirements for flame spread and smoke generation.

Unit shall have a sloped drain pan that conforms to ASHRAE Standard 62.2.

ACCESSORIES

Field-installed accessories shall include solid-state compressor short-cycle device, outdoor thermostat, thermostat and subbase, electric heaters with single-point connection, crankcase heater, low- and high pressure switch kits, and low-ambient kit.