

Accessory Leveling Legs For Use With Packaged Terminal Air Conditioner or Heat Pump

Cancels: New

IJK 84-07-6
6/15/03

Installation Instructions

INTRODUCTION

These instructions cover the installation of the Accessory Leveling Legs. The Accessory Leveling Legs are constructed of sheet metal and are designed to offer accurate leveling and support for units without a subbase. Leveling legs are adjustable from 3¹/₄ in. to 5¹/₂ in. See Fig. 1.

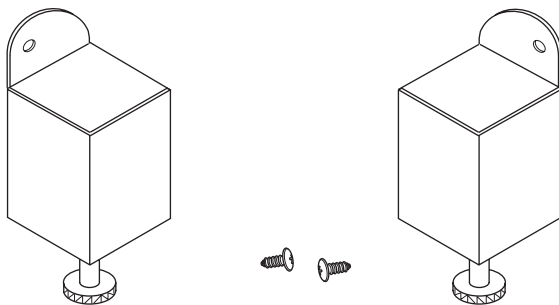

Fig. 1 — Accessory Leveling Legs

INSTALLATION

⚠ WARNING

Disconnect all power to unit to avoid possible electrical shock during installation.

Step 1 — Drill a 1/8 in. diameter hole on each side of wall sleeve. See Fig. 2 for mounting hole location (plastic wall sleeve will have a locator dimple).

Step 2 — Install leveling legs to wall sleeve using screws provided (do not over tighten).

NOTE: There is a right and a left leveling leg, be sure leveling legs are mounted so that the majority of the leg supports the sleeve (see Fig. 3).

Step 3 — Adjust leveling bolts to properly level and support sleeve (see Fig. 4).

Step 4 — Install PTAC (packaged terminal air conditioner) unit into wall sleeve.

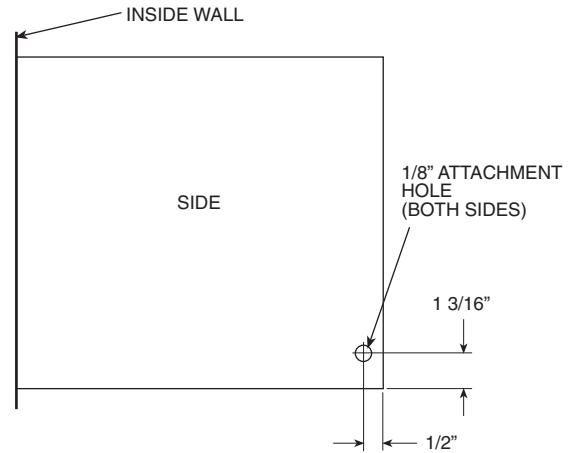

Fig. 2 — Wall Sleeve

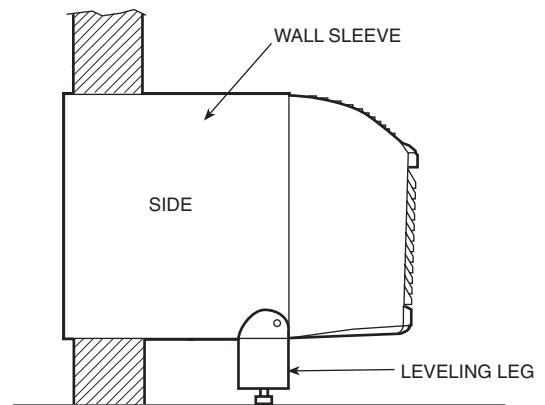

Fig. 3 — Leveling Leg (Side View)

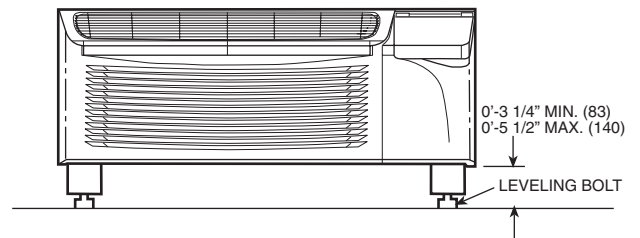

Fig. 4 — Leveling Legs (Front View)