

Wall Thermostat with 2 Speed Fan Control Kit For Use with Packaged Terminal Air Conditioner

Cancels: IIK 84-07-4

IIK 84-07-11
3/15/04

Installation Instructions

SAFETY CONSIDERATIONS

Only trained, qualified personnel and service mechanics should modify and install any electrical accessories on packaged terminal air conditioners or heat pumps.

PACKAGE CONTENTS

ITEM	QUANTITY
Wall Thermostat P/N 33CSSN2-MH	1
Relay Assembly	1
Screws (no. 8 x 3/8 in.)	2
Plastic Rectangular Plug	1
Crimp Type Wire Joint	1
Wire Ties	2
Blank Out Control Panel Label	1

INTRODUCTION

These instructions cover the installation of a wall thermostat (included, P/N 33CSSN2-MH) and the installation of a second fan speed control relay inside the unit control box (of an RC or RP unit), to provide two-speed fan control from the wall thermostat. See Fig 1.

The two-speed fan control kit provides full fan speed control of the PTAC (packaged terminal air conditioner) unit from the wall thermostat (included).

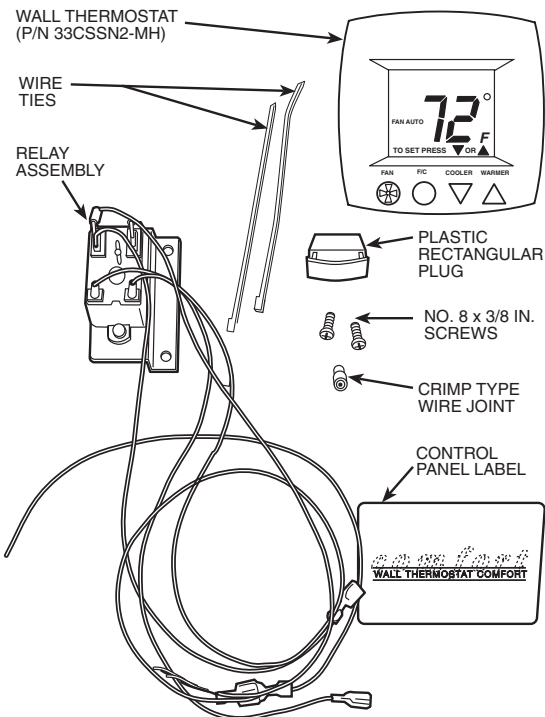

Fig. 1 — Wall Thermostat with Two-Speed Fan Control Kit

⚠ WARNING

Disconnect all power to unit to avoid possible electrical shock during installation.

INSTALLATION

NOTE: This kit can only be installed on wall thermostat units (RC or RP models).

Prepare Unit

1. Check to be sure the unit is off and power to the unit is disconnected.
2. Remove the unit's front panel by grasping it firmly near the bottom of both sides, then pulling panel forward and upward to release magnetic latches and partition hooks.

Install Second Fan Speed Control Relay

1. Remove the terminal access cover and save. See Fig. 2.
2. Open the control box by removing the 2 control box cover screws shown in Fig. 2. Swing the cover down to open. Save the screws.
3. Attach the relay assembly to the 2 holes in the right side of the control box as shown in Fig. 3, using two no. 8 x 3/8 in. screws included.

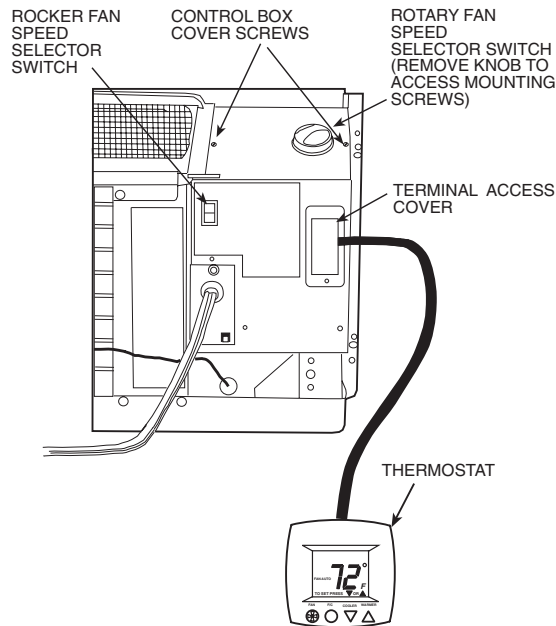

Fig. 2 — Control Box Terminal Cover for Wall Thermostat Models

Manufacturer reserves the right to discontinue, or change at any time, specifications or designs without notice and without incurring obligations.

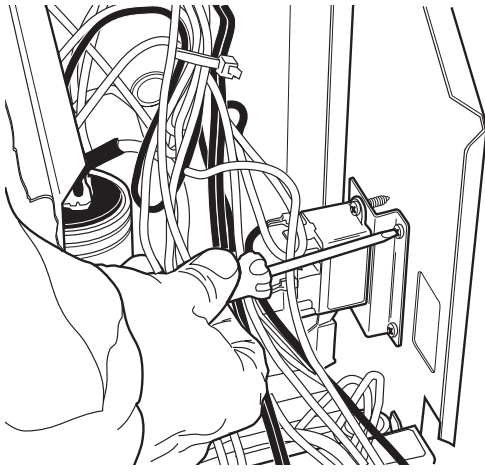

Fig. 3 — Mount Relay Assembly on the Right Side of the Control Box

Wire in Second Fan Speed Control Relay

1. Remove the gray fan speed selector wire by disconnecting it from the J2 terminal next to relay K3 on the PCB (printed circuit board) and the fan speed selector switch. See Fig. 4.

NOTE: The gray wire will either be connected to a rotary fan speed selector switch on top of the control box OR a rocker fan speed selector switch (as shown in Fig. 4) on the front of the control box cover.

2. Attach the gray wire from the relay assembly to terminal J2 next to relay K3 on the PCB. See Fig. 4.
3. Remove the black fan wire from the fan speed selector switch (rotary or rocker) and re-attach it to terminal 4 on the relay assembly. See Fig. 4 and 5.
4. Remove the red fan wire from the fan speed selector switch (rotary or rocker) and re-attach it to terminal 6 on the relay assembly. See Fig. 4 and 5.
5. Remove fan speed selector switch.

For wall thermostat units with a rotary fan speed selector switch on top of the control box cover:

- Remove the knob and rotary fan speed selector switch from the control box cover by removing the 2 screws located under the knob shown in Fig. 2. Discard the knob and switch.

For wall thermostat units with a rocker fan speed selector switch on the front of the control box cover:

- Remove the rocker fan speed selector switch from the control cover and replace with the plastic rectangular plug provided in the relay kit. See Fig. 2 and 6.

6. Remove the black wire from L1 on relay K1.
7. Attach the black wire from terminal 2 of relay assembly (with goal post terminal) to L1 on relay K1.
8. Re-attach the black wire (removed in step 6 above) to open goal post terminal of L1 on relay K1. See Fig. 4.
9. Attach the green ground wire from terminal 1 of the relay assembly (with piggy back male terminal) to the green ground wire attached to the PE terminal on corner of the PCB. Attach both wires back on to the PE terminal on corner of the PCB. See Fig 7.
10. The blue wire connected to terminal 3 on the relay assembly is the second fan speed signal wire, for connection to the thermostat. The blue wire has a quick connect/disconnect terminal for easy disconnect and removal of the unit. Route the blue wire out of the control box opening where the terminal access cover was removed. See Fig. 8.

11. Dress the wires using the wire ties provided.
12. Close the control box door and secure it by re-attaching the screws saved earlier (take care not to pinch any of the wires when the control box cover is closed).

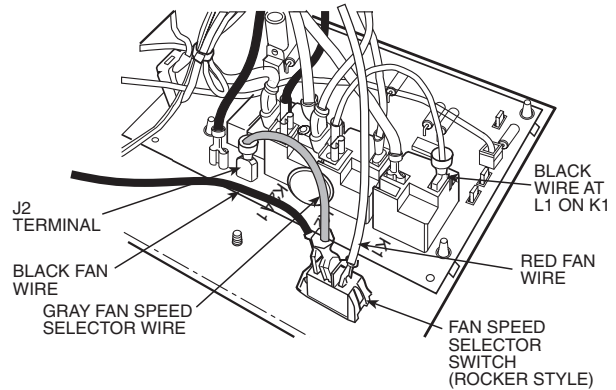

Fig. 4 — Fan Speed Selector Wire

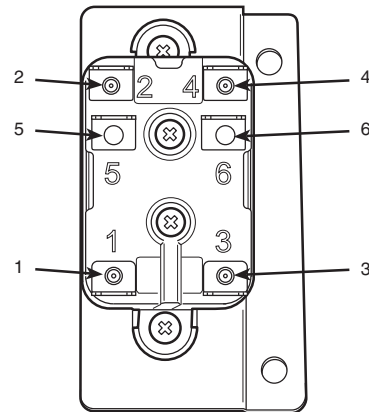

Fig. 5 — Relay Assembly Connections

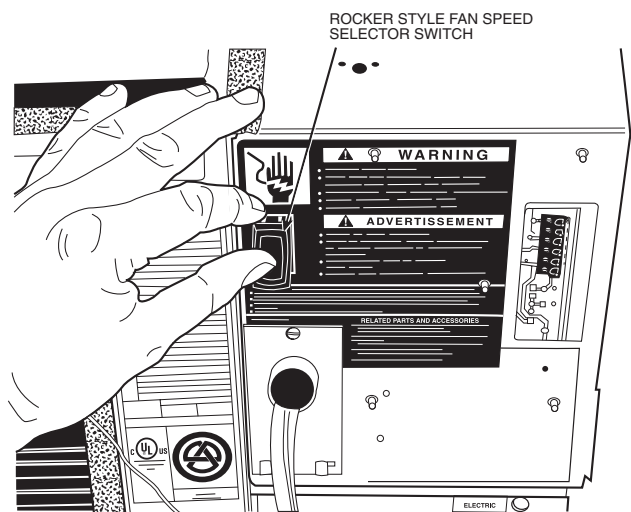

Fig. 6 — Remove Fan Speed Selector Switch

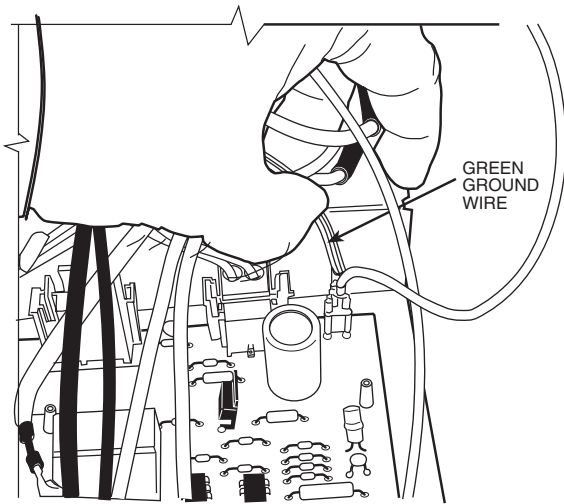

Fig. 7 — Ground Wire Connection

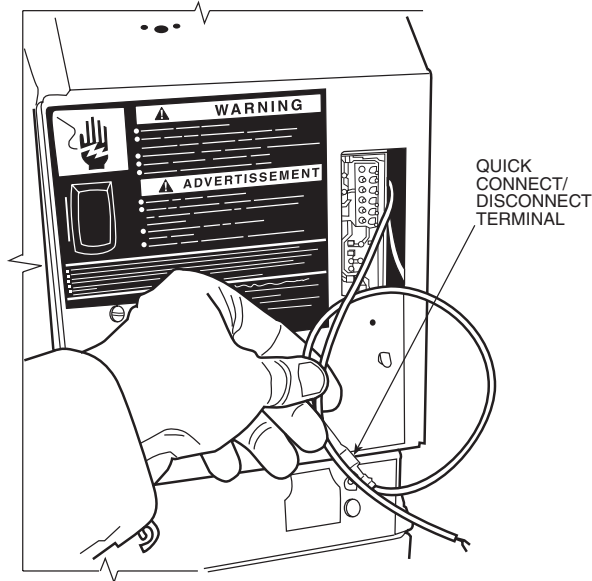

Fig. 8 — Route Second Fan Speed Signal Wire Out of the Control Box

Connect Wall Thermostat

1. Mount the wall thermostat to the wall (install per mounting instructions included with the thermostat).
2. Remove the wall thermostat terminal block from the PTAC unit, accessible through the terminal access opening. See Fig. 9.
3. Wire wall thermostat to the terminal block removed in previous step. See Fig. 10 and 11.

NOTE: Connect G2 to the blue wire for second fan speed with the crimp-type wire joint included with the kit.

4. Re-install the fully wired wall thermostat terminal block to the PTAC unit through the terminal access opening. See Fig. 9.
5. Re-install the terminal access cover. See Fig. 2.
6. Re-install the front panel.
7. If a rotary speed selector switch was removed in Step 5 of the previous section, there will be a hole in the control section of the front panel (where HI/LOW fan speed was selected). Cover the hole by replacing the existing control

panel label with the blank out control label included. See Fig. 12.

8. Restore power to the unit.

IMPORTANT: Wall thermostat must be configured for the correct equipment type for proper operation. Program Heat Pump units with equipment type 11 and Heat/Cool units with equipment type 13. Refer to next section, Required Setup of Thermostat.

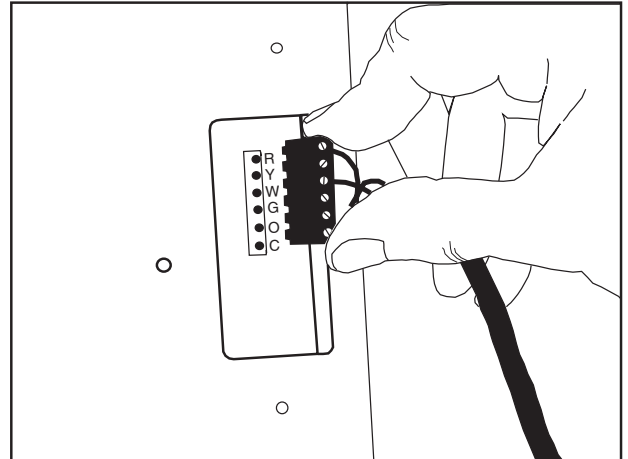
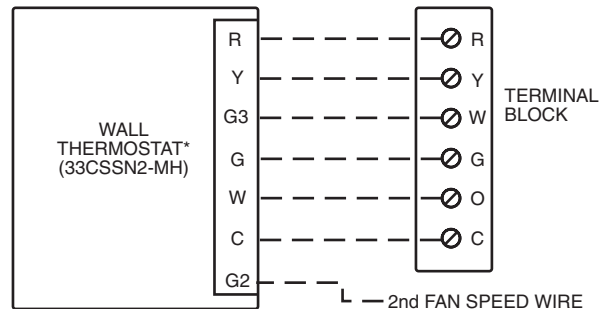
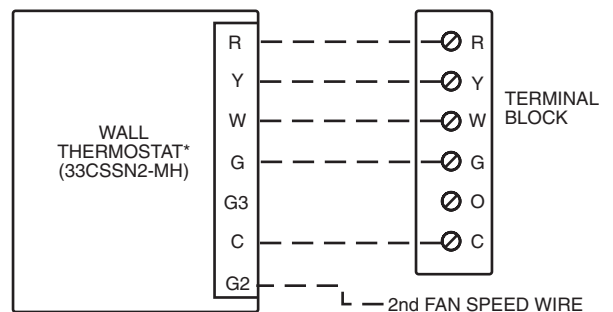

Fig. 9 — Terminal Connector Removal and Replacement



*Physical location of terminals on thermostat may vary.

Fig. 10 — Wall Thermostat Wiring Connections (Heat Pump Units — 7 Wires)



*Physical location of terminals on thermostat may vary.

Fig. 11 — Wall Thermostat Wiring Connections (Heat/Cool Units — 6 Wires)

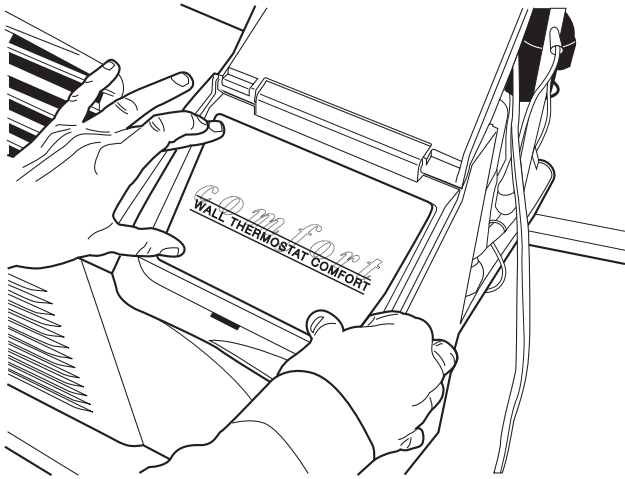

Fig. 12 — Apply Blank Out Control Panel Label

Required Setup of Thermostat

1. Enter Advanced Configuration mode. See Fig. 13.
2. The only configuration item that must be changed is the equipment type. For a heat pump unit, the equipment type must be changed to 11. For a Heat/Cool unit, the equipment type must be changed to 13.

IMPORTANT: Failure to configure the Wall Thermostat with the correct type of equipment will result in improper operation of the thermostat and possibly, damage to the PTAC unit.

Thermostat Operation

1. Refer to the instructions included with the thermostat for basic operation and configuration. For additional information on unit to thermostat wiring see Fig. 14 and 15.
2. Once the thermostat has been fully installed and configured, test all operating modes and fan speed control.

NOTE: Set the thermostat to 'OFF' mode before adjusting settings.

NOTE: Each step's description is located at the top right corner of the display for easy reference.

FAN **Press the Fan button for 10 seconds to enter these Setup screens.**

This step only appears in compressor

<p>*Select the cycles per hour limit. d = cycles per hour limit detected. (d, 2-6) Default = 6 cycles/hour</p>	<p>CYCLES/HOUR</p> <p style="font-size: 2em;">6</p> <p>TO SET PRESS. OR </p>	<p>Press FAN </p>
<p>Adjust the deadband from 1 -6 degrees F. Deadband is the difference between Room temperature & setpoint before the equipment will turn on. Default = 2 degrees</p>	<p>DEADBAND</p> <p style="font-size: 2em;">2</p> <p>TO SET PRESS. OR </p>	<p>Press FAN </p>
<p>†Adjust the minimum temperature setpoint that is used when the thermostat indicates OFF. Heat will come on when the temperature falls below this setpoint. Default = 60 degrees</p>	<p>OFF MIN SETPOINT</p> <p style="font-size: 2em;">60</p> <p>TO SET PRESS. OR </p>	<p>Press FAN </p>
<p>†Adjust the maximum temperature setpoint that is used when the thermostat indicates OFF. Cooling will come on when the temperature rises above this setpoint. Default = 85 degrees</p>	<p>OFF MAX SETPOINT</p> <p style="font-size: 2em;">85</p> <p>TO SET PRESS. OR </p>	<p>Press FAN </p>
<p>Adjust the length of time the fan will continue to run after the temperature is satisfied. (To purge the system) (0-90 seconds, in 15 second increments) Default = 30 seconds</p>	<p>FAN PURGE</p> <p style="font-size: 2em;">30</p> <p>TO SET PRESS. OR </p>	<p>Press FAN </p>
<p>Select the type of equipment this thermostat is connected to (11 for Heat Pump or 13 for Heat/Cool unit).</p>	<p>EQUIPMENT TYPE</p> <p style="font-size: 2em;">1</p> <p>TO SET PRESS. OR </p>	<p>Press FAN </p>





To exit setup screen
Press
F/C

IMPORTANT: Configuration of equipment type must be changed.

*The purpose of d1 is to allow the installing technician to override the thermostat's 5-minute compressor lockout. After installation is complete this setting should be set between d and 6 cycles per hour.
†This feature prevents rooms from getting too hot or too cold when heating or cooling is turned off.

Fig. 13 — Thermostat Advanced Configuration Setup

LEGEND

-  MARKED TERMINAL
-  MULTIPLE TERMINAL
-  COMPONENT SUPPLIED WIRE
-  FIELD SUPPLIED T' STAT WIRING

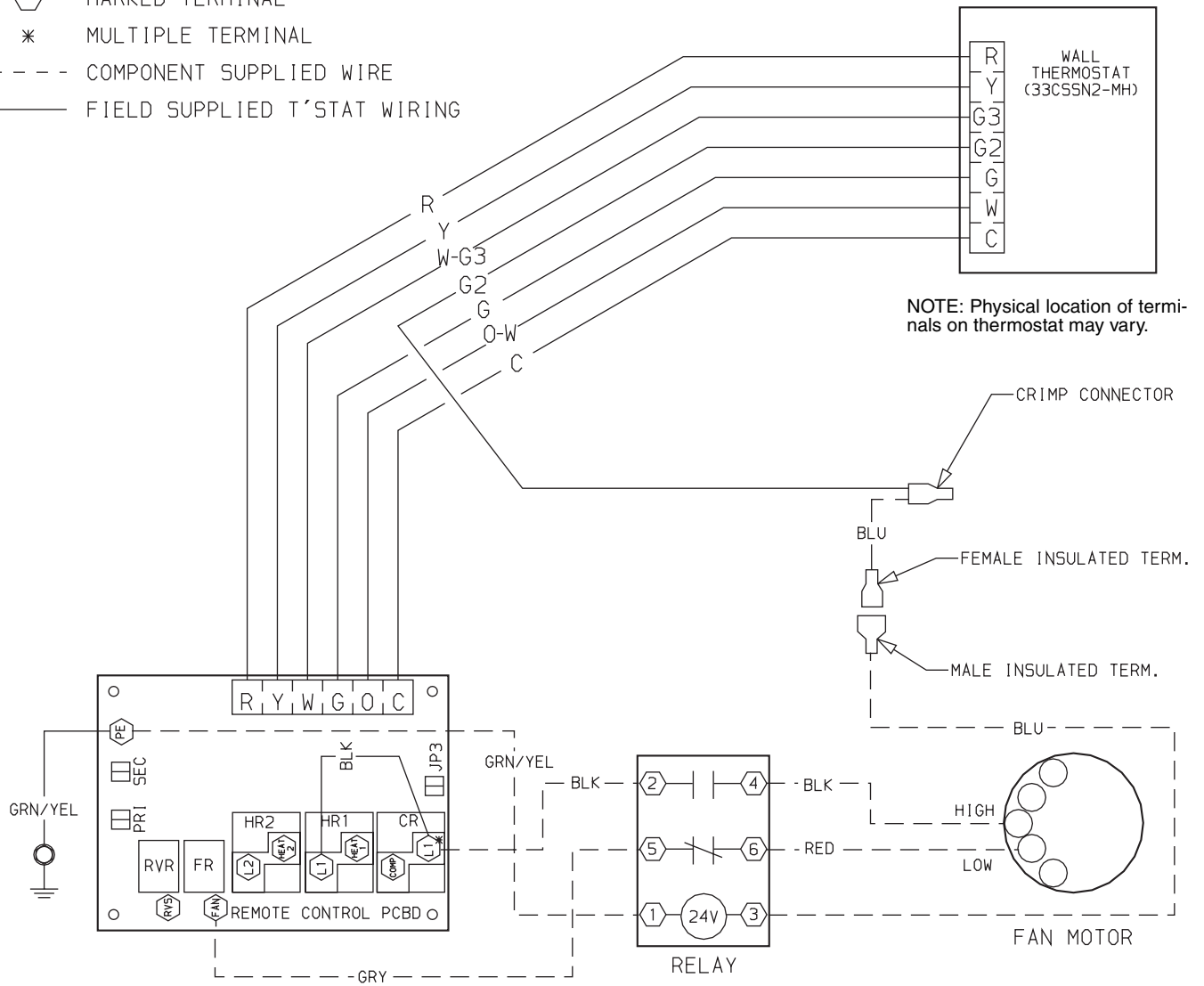

NOTE: Physical location of terminals on thermostat may vary.

NOTE: Wall thermostat must be configured for the correct equipment type for proper operation.

IMPORTANT: Program heat pump units with Equipment Type 11. See thermostat advanced configuration setup (Fig. 13) instructions for programming equipment type.

Fig. 14 — Thermostat Wiring Schematic (Equipment Type 11 — Heat Pump)

LEGEND

-  MARKED TERMINAL
- * MULTIPLE TERMINAL
- - - COMPONENT SUPPLIED WIRE
- FIELD SUPPLIED T' STAT WIRING

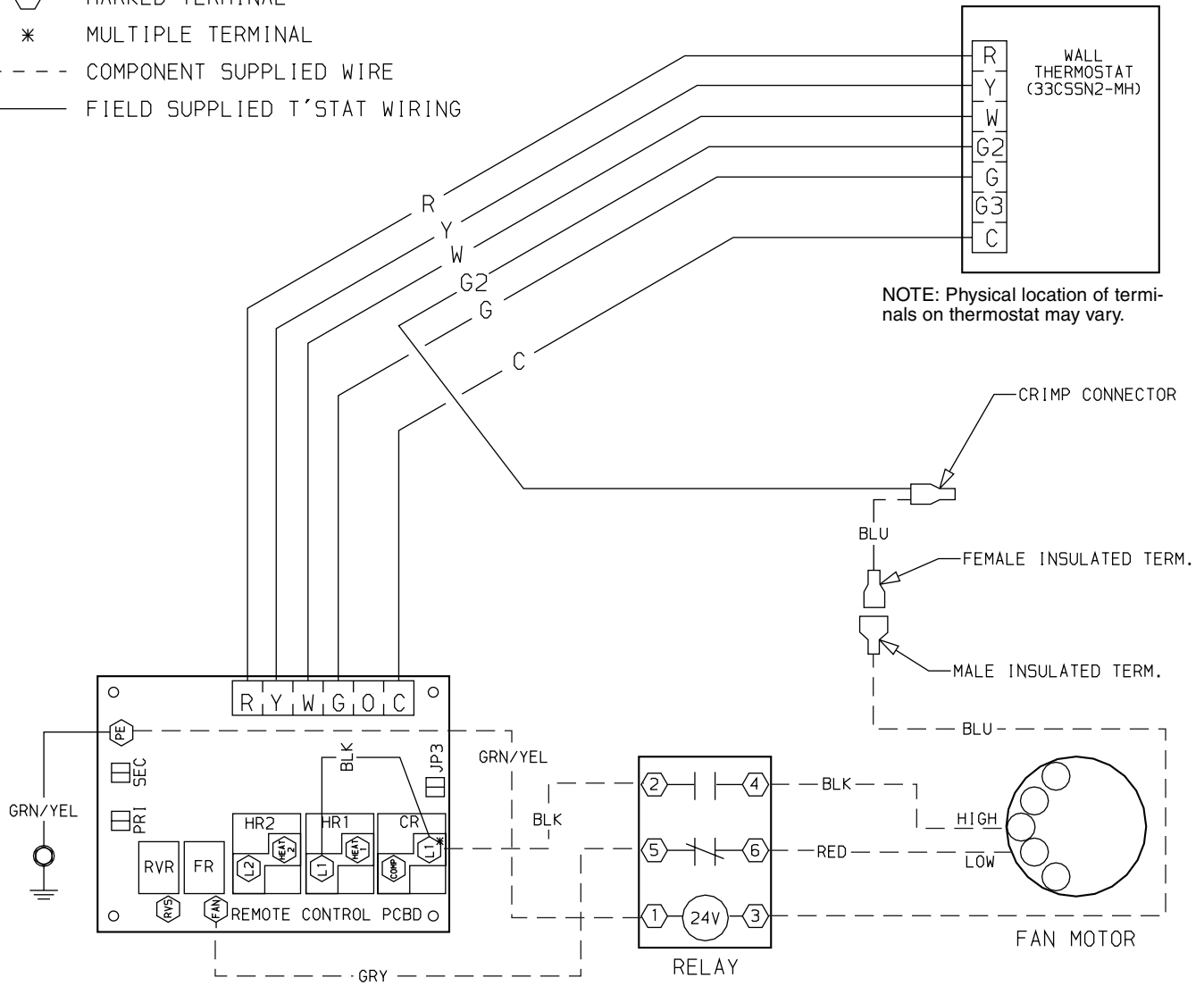

NOTE: Physical location of terminals on thermostat may vary.

NOTE: Wall thermostat must be configured for the correct equipment type for proper operation.

IMPORTANT: Program heat/cool units with Equipment Type 13. See thermostat advanced configuration setup (Fig. 13) instructions for programming equipment type.

Fig. 15 — Thermostat Wiring Schematic (Equipment Type 13 — Heat/Cool)

