

# Energy Management (EM) Accessory Kit For Use With Packaged Terminal Air Conditioner or Heat Pump

## Installation Instructions

### INTRODUCTION

These instructions cover the installation of the Energy Management (EM) accessory kit with Freeze Guard Thermostat for packaged terminal air conditioner (PTAC) units. See Fig. 1.

The EM accessory allows individual PTAC units to be turned off from a remote location, such as from a hotel front desk control, to conserve energy when the room is unoccupied.

The freeze guard thermostat prevents the room from freezing by overriding the control of the EM accessory. If the EM accessory has turned the unit off, then the freeze guard thermostat overrides control of the EM accessory to allow power to the unit when the room temperature drops to 45 F and then returns control of the EM accessory to the unit when the temperature in the room reaches 60 F.

#### NOTES:

1. The Freeze Guard feature only operates properly when the unit is in HEAT mode.
2. Low voltage 24 vac power must be supplied from the remote location.

### PACKAGE CONTENTS

ITEM	QUANTITY
EM Control Assembly	1
Hardware Assembly Packet	1
Freeze Guard Thermostat	1

**IMPORTANT:** The manufacturer currently does not supply front desk control equipment. This equipment should be handled through your local electrical contractor.

### INSTALLATION

#### ⚠ WARNING

Disconnect all power to unit to avoid possible electrical shock during installation.

**Step 1** — Disconnect all power to unit.

**Step 2** — Remove front panel from the unit by grasping the panel firmly near the bottom of both sides and pulling forward, then upward to release magnetic latches and partition hooks. See Fig. 2.

**Step 3** — Open control box by removing the 2 control box cover screws. See Fig. 3.

**Step 4** — Locate low voltage knockout on side of control box cover. See Fig. 4. From inside of unit, use screwdriver to push out one corner of low voltage knockout. See Fig. 5A. Remove low voltage knockout with pliers. See Fig. 5B.

**Step 5** — Remove existing partition screw located on side of basepan. Save the screw. See Fig. 4.

**NOTE:** For ease of installation, connect all wiring to EM control before mounting EM control to bottom of control box. See Fig. 6.

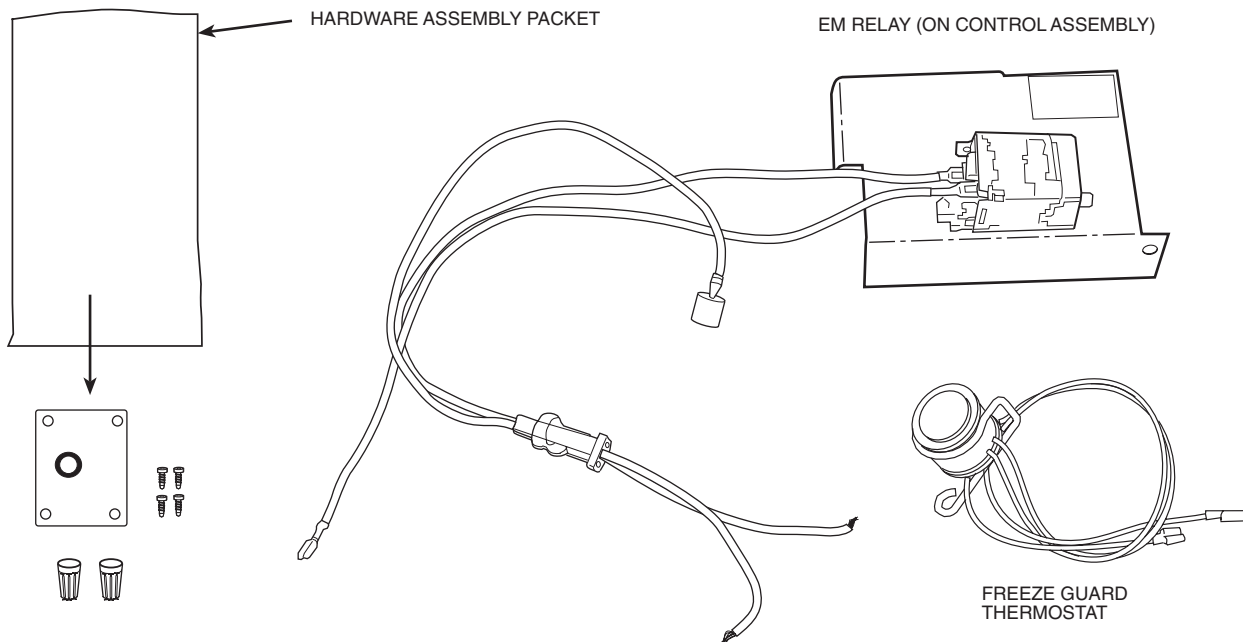

**Fig. 1 — Energy Management (EM) Accessory Kit**

**Step 6** — Remove the L1 power cord wire from the selector switch and connect it to unused terminal 1 on EM control relay. Note the original connection and location of L1 for the next step. See Fig. 6 and 7.

**Step 7** — Run the yellow wire from EM control to location on selector switch where L1 was previously connected.

**Step 8** — Push the Freeze Guard thermostat wires through the thermostat sensor bushing located on lower left corner of control box. See Fig. 8.

**Step 9** — Connect Freeze Guard black wire with 1/4-in. quick connect to unused terminal B on EM control relay. See Fig. 6.

**Step 10** — Connect the other Freeze Guard black wire with the pin terminal into open position in plastic two-circuit connector. See Fig. 6 and 9.

**Step 11** — Install the EM control assembly on the bottom of the control box. Line up EM plate attachment hole with hole in basepan where screw was removed in Step 5. Reattach partition screw, securing the partition and EM control to the basepan. See Fig. 4 and 10.

**Step 12** — Route 24 vac field-supplied wires into the control box, through the bushing of the access cover. See Fig. 11.

**Step 13** — Using wire nuts supplied, connect 24 vac field-supplied wires to black and white EM control wires; no polarity is required.

**Step 14** — Carefully position all wiring into control box through low voltage opening.

**Step 15** — Secure access cover to side of control box with four screws provided in hardware assembly packet.

**Step 16** — Close and secure control box.

**Step 17** — Remove screw from upper partition on unit. See Fig. 8. Install Freeze Guard thermostat with screw.

**Step 18** — Fold and insert EM and unit schematics into plastic bag on front of control box for easy access. See Fig. 8.

**Step 19** — Replace the front panel.

**Step 20** — Restore electrical power to the unit.

**Installation for Control Desk Operation** — The following is required for control desk operation:

- Coil Inrush — 15 va
- Coil Sealed — 3.5 va

The contacts on the relay provided with the EM accessory kit are normally closed. Therefore if the control desk provides 0 volts (no power) to the terminal board, the unit operates normally. If the control desk provides 24 vac to the terminal

board, the EM control relay contacts open and the unit is disabled.

**NOTE:** The Freeze Guard feature only operates properly when the unit is in Heat mode.

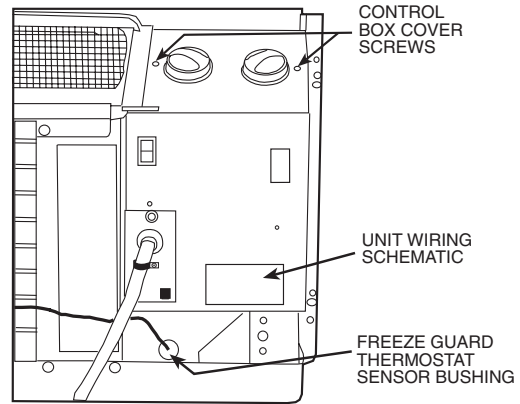

**Fig. 3 — Control Box Component Location**

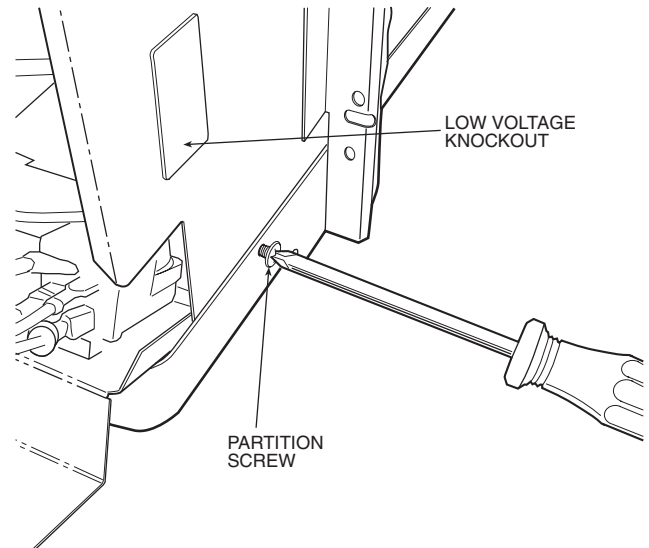

**Fig. 4 — Basepan Partition Screw Removal**

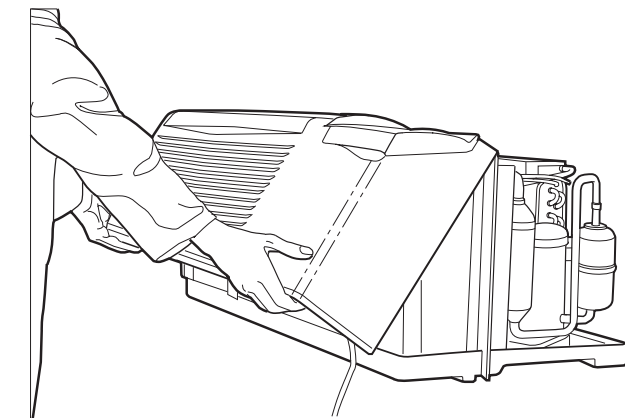

**Fig. 2 — Removing Front Panel from Unit**

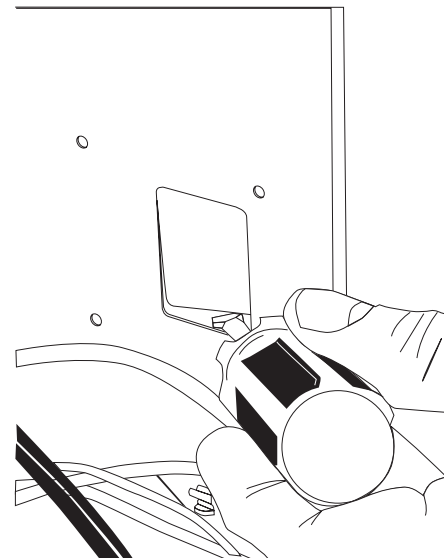

**Fig. 5A — Preparation of Low-Voltage Knockout for Removal**

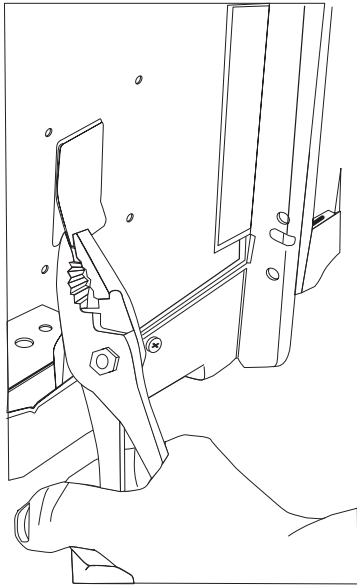

**Fig. 5B — Removing Low-Voltage Knockout**

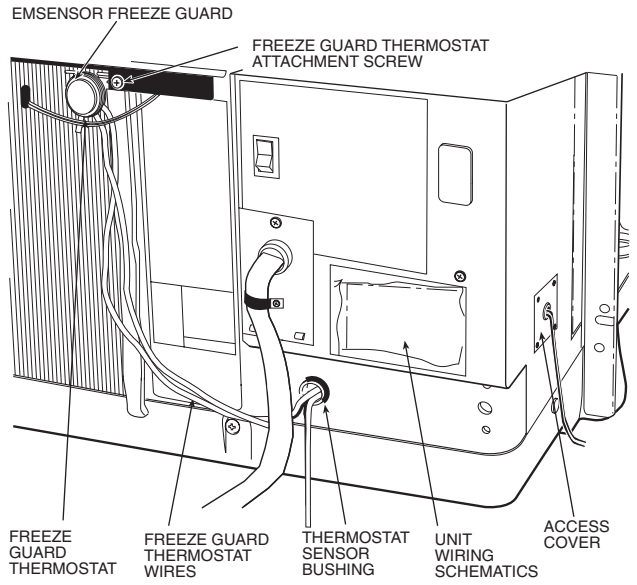

**Fig. 8 — Location of Freeze Guard Thermostat and Wires Through Bushing on Control Box**

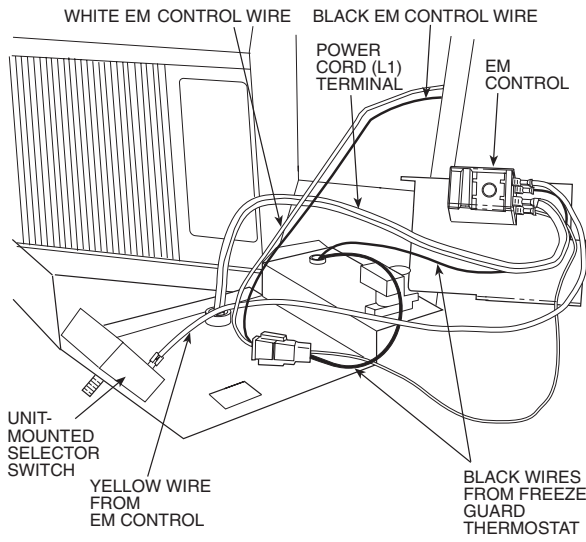

**Fig. 6 — EM Control Wiring to Unit**

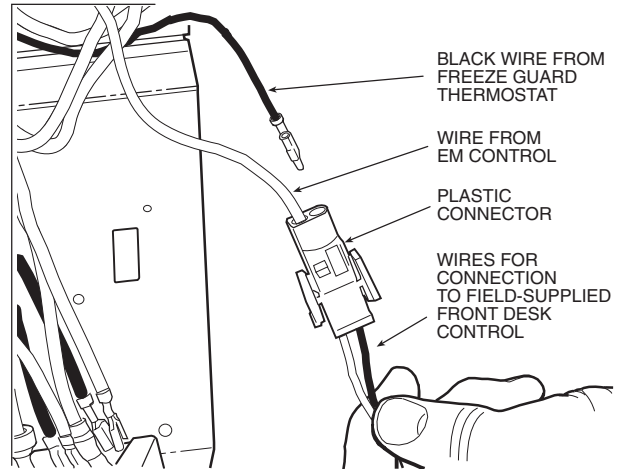

**Fig. 9 — Freeze Guard Wiring Connection to Open Terminal in Plastic Connector**

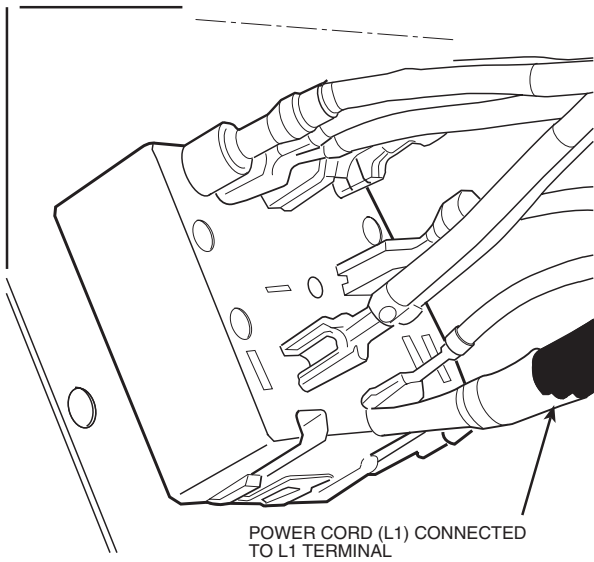

**Fig. 7 — Unit-Mounted Selector Switch Wiring**

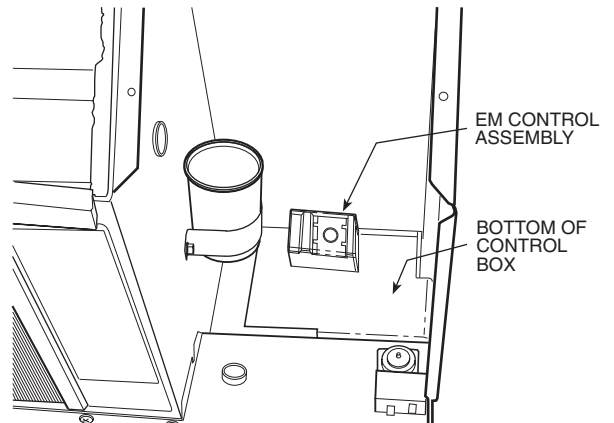

**Fig. 10 — Location of EM Control Assembly on Bottom of Control Box**

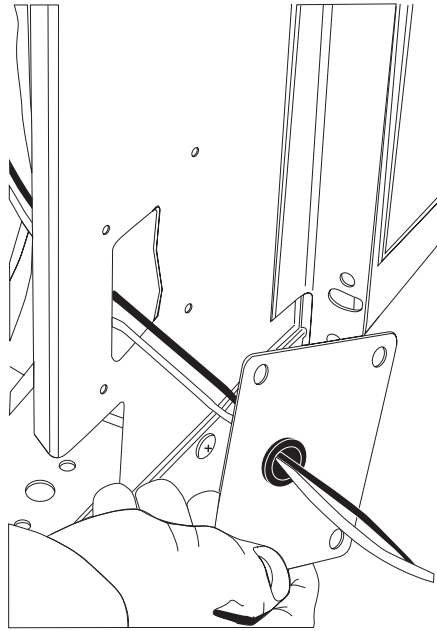

**Fig. 11 — Wiring and Low-Voltage Opening Location**