

# Standard Polymer Wall Sleeve Accessory For Use With Packaged Terminal Air Conditioner or Heat Pump

Cancels: New

IIK 830-07-2  
6/15/00

## Installation Instructions

### INTRODUCTION

These instructions cover the installation of standard polymeric (plastic) wall sleeves through masonry, steel or wood frame, or curtain walls. Fasteners are field supplied.

The wall sleeve is shipped separately from the air conditioner chassis. A cardboard filler panel on the rear of sleeve provides weather protection, and a cardboard center support provides needed support until the chassis and rear grille are installed. The chassis is secured with 4 screws into clips that are factory installed on the front flanges of the sleeve. See Fig. 1.

### BEFORE INSTALLATION

**Select Location** — When selecting wall sleeve location, allow at least 14 in. from front of sleeve for removal of front panel and unit chassis for maintenance. The sleeve may be installed flush against the floor (including carpeting), except for units with subbase. See below.

**NOTE:** Front panel may have to be notched to allow exit of electrical cord.

For cord-connected units, an electrical receptacle must be located within reach of service cord. Measure receptacle location from outside corner of the sleeve. See Table 1.

**Table 1 — Maximum Receptacle Distances,  
in. (mm)**

VOLTAGE	TO LEFT OF SLEEVE	TO RIGHT OF SLEEVE
230/208	18 (457)	36 (914)
265	*	*

\*The 265-v units typically are hardwired, or if an accessory cord kit is used, it will not extend beyond bottom of unit.

**UNITS WITH SUBBASE** — The sleeve must be installed 3<sup>1</sup>/<sub>4</sub> in. minimum to 5<sup>1</sup>/<sub>2</sub> in. maximum above floor (including carpeting). This accommodates subbase height of 3 in. minimum (when screws are down) to 5 in. maximum (when screws are extended). The wall base is 3 in. wide, therefore sleeve must project into room at least 3<sup>1</sup>/<sub>4</sub> inches.

**IMPORTANT:** If sleeve projects more than 4 in. into a room, the manufacturer recommends a subbase to support the wall sleeve. This will prevent the sleeve from sagging.

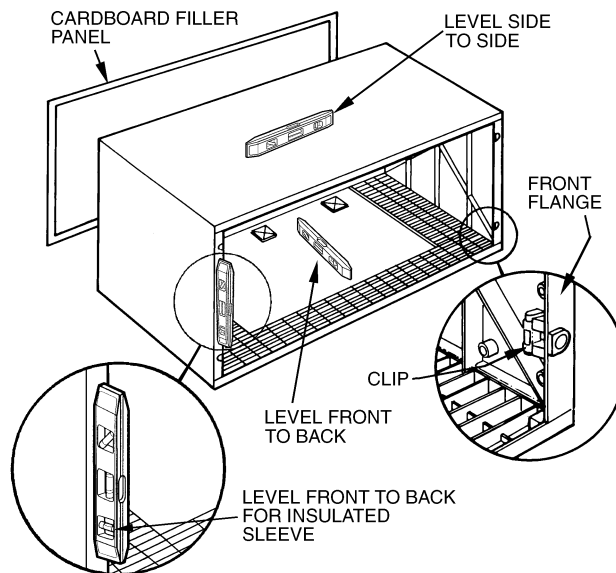

**Fig. 1 — Wall Sleeve Installation**

**ALL UNITS** — Extend the wall sleeve at least 5/8 in. beyond building exterior to assure proper drainage and to allow weathertight caulking.

The sleeve must project at least 1/4 in. into room when installed (for proper caulking).

**Opening Size** — Recommended minimum wall opening is 42<sup>1</sup>/<sub>4</sub> in. wide x 16<sup>1</sup>/<sub>8</sub> in. high.

**IMPORTANT:** Sleeve must be mounted level in all directions. A 1/4-in. pitch is built into the unit chassis for proper condensate drainage. See Step 3.

**MASONRY WALLS** — Use a lintel to support the wall above the opening. The opening may be framed in wood, with the sleeve secured by wood screws, or the sleeve may be fastened to masonry walls with masonry screws (field supplied).

**STEEL/WOOD FRAMING** — Use good construction practices such as those used in window framing. Mounting angles, if used, must be field fabricated and installed. All fasteners are field supplied.

## TO INSTALL SLEEVE

**Step 1 — Cut Opening in Wall** — For opening location and size, refer to the Before Installation section.

**Step 2 — Prepare Sleeve** — Remove the cardboard center support. If unit is to be installed at this time, discard support. If unit is to be installed later, save cardboard support for reinstallation in later step.

If grille is to be installed at this time, remove and discard rear panel. Position the sleeve in the wall opening with the bottom down and the drain holes toward the outdoors.

**Step 3 — Mount Sleeve in Wall** — Protrusions and/or indentations are provided in the sides and top of sleeve to permit drilling holes for mounting.

1. Drill proper size holes through the appropriate locations in the sleeve (some possible locations have been predetermined and molded into the sleeve). **DO NOT DRILL ANY HOLES IN THE BOTTOM PANEL OF THE SLEEVE.**

**IMPORTANT:** Never install fasteners through bottom of sleeve.

2. Check for the correct amount of sleeve insertion into the room then fasten one side of sleeve to the wall using

appropriate, field supplied fasteners. Level the sleeve front to back and side to side (see Fig. 1).

**IMPORTANT:** Do not place the level on bottom panel rib sections or bottom panel of insulated sleeve since they are pitched front to back to provide unit drainage. Insulated sleeve should be checked by placing a vertical level on the interior flange of the sleeve. Refer to Fig. 1.

Use shims where needed. Fasten the other side of the sleeve to the wall. Fasten the top of the sleeve to the wall (use shims at fastener locations to fill any gaps and prevent distortion of the sleeve).

3. If outdoor grille and chassis are to be installed at a later time, replace the cardboard center support removed in earlier step.
4. Caulk inside and outside to make sleeve weathertight.

### **⚠ CAUTION**

Only a manufacturer-authorized outdoor grille should be used with this packaged terminal air conditioner. Use of any other grille must be approved in writing by manufacturer.