

# Standard Metal Wall Sleeve Accessory For Use With Packaged Terminal Air Conditioner or Heat Pump

Cancels: New

IIK 830-07-4  
12/15/00

## Installation Instructions

### INTRODUCTION

These instructions cover the installation of standard metal wall sleeves through masonry, steel or wood frame, or curtain walls. Fasteners are field supplied.

The wall sleeve is shipped separately from the air conditioner chassis. A cardboard weather barrier on the rear of sleeve provides weather protection. The chassis is secured with 4 screws into clips that are factory installed on the front flanges of the sleeve. See Fig. 1.

### BEFORE INSTALLATION

**Select Location** — When selecting wall sleeve location, allow at least 14 in. from front of sleeve for removal of front panel and unit chassis for maintenance. The sleeve may be installed flush against the floor (including carpeting), except for units with subbase. See below.

For cord-connected units, an electrical receptacle must be located within reach of service cord. Measure receptacle location from outside corner of the sleeve. See Table 1.

**Table 1 — Maximum Receptacle Distances, in. (mm)**

VOLTAGE	TO LEFT OF SLEEVE	TO RIGHT OF SLEEVE
230/208	18 (457)	36 (914)
265	*	*

\*The 265-v cord will not extend beyond bottom of unit.

**UNITS WITH SUBBASE** — The sleeve must be installed 3<sup>1</sup>/<sub>4</sub> in. minimum to 5<sup>1</sup>/<sub>2</sub> in. maximum above floor (including carpeting). This accommodates subbase height of 3 in. minimum (when screws are down) to 5 in. maximum (when screws are extended). The wall base is 3 in. wide, therefore sleeve must project into room at least 3<sup>1</sup>/<sub>4</sub> inches.

**IMPORTANT:** If sleeve projects more than 4 inches into a room, the manufacturer recommends a subbase to support the wall sleeve. This will prevent the sleeve from sagging.

**ALL UNITS** — Extend the wall sleeve at least 5/8 in. beyond building exterior to assure proper drainage and to allow weathertight caulking.

The sleeve must project at least 1/4 in. into room when installed (for proper caulking).

**Opening Size** — Recommended minimum wall opening is 42<sup>1</sup>/<sub>4</sub> in. wide x 16<sup>1</sup>/<sub>8</sub> in. high.

**IMPORTANT:** Sleeve must be mounted level in all directions. A 1/4-in. pitch is built into the unit chassis for proper condensate drainage. See Step 3 — Mount Sleeve in Wall.

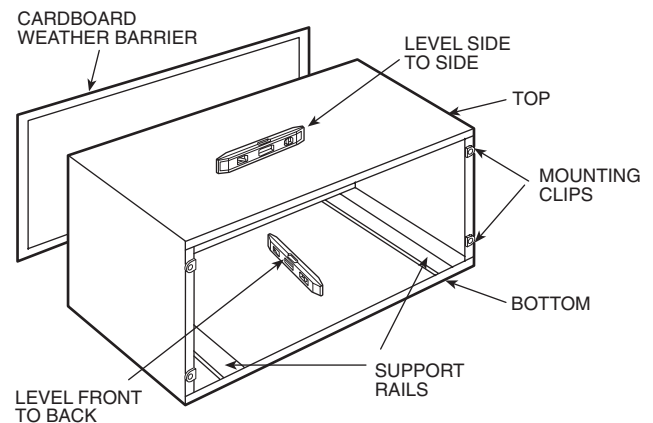

**Fig. 1 — Wall Sleeve Installation**

**MASONRY WALLS** — Use a lintel to support the wall above the opening. The opening may be framed in wood, with the sleeve secured by wood screws, or the sleeve may be fastened to masonry walls with masonry screws (field supplied).

**STEEL/WOOD FRAMING** — Use good construction practices such as those used in window framing. Mounting angles, if used, must be field fabricated and installed. All fasteners are field supplied.

## TO INSTALL SLEEVE

**Step 1 — Cut Opening in Wall** — For opening location and size, refer to the Before Installation section.

**Step 2 — Prepare Sleeve** — If grille is to be installed at this time, remove and discard rear panel. Position the sleeve in the wall opening with the bottom down and the drain holes toward the outdoors.

**IMPORTANT:** The sleeve is assembled with insulation to provide a thermal barrier between indoor and outdoor air. For optimal unit operation, do not remove the insulation.

**Step 3 — Mount Sleeve in Wall** — Proper size holes for mounting are field customized, based on each separate installation.

**NOTE:** There are no protrusions or indentations in the sides or top of the sleeve for drilling mounting holes.

1. Drill proper size holes through the appropriate locations in the sleeve. **DO NOT DRILL ANY HOLES IN THE BOTTOM PANEL OF THE SLEEVE.**

**IMPORTANT:** Never install fasteners through bottom of sleeve.

2. Check for the correct amount of sleeve insertion into the room then fasten one side of sleeve to the wall using appropriate, field-supplied fasteners. Level the sleeve front to back and side to side (see Fig. 1).

Use shims where needed. Fasten the other side of the sleeve to the wall. Fasten the top of the sleeve to the wall (use shims at fastener locations to fill any gaps and prevent distortion of the sleeve).

3. If outdoor grille and chassis are to be installed at a later time, leave the cardboard weather barrier in place.
4. Caulk inside and outside to make sleeve weathertight. Caulk all joints between sleeve and opening in wall.

**NOTE:** Under certain high humidity conditions, the unit may not dispose of all its condensate. The installation of an external drain system is recommended.

### **⚠ CAUTION**

Only a manufacturer-authorized outdoor grille should be used with this packaged terminal air conditioner. Use of any other grille must be approved in writing by manufacturer.