

High Output PSC Inducer Motor Housing Assembly Kit

Cancels: IIK 340M-40-67 IIK 340M-40-92
8-05

Installation Instructions Part No. 320725-754 and 755

NOTE: Read the entire instruction manual before starting the installation.

This symbol → indicates a change since the last issue.

SAFETY CONSIDERATIONS

Installing and servicing of heating equipment can be hazardous due to gas and electrical components. Only trained personnel should install or service heating equipment.

Untrained personnel can perform basic maintenance functions such as cleaning coils or cleaning and replacing filters. All other operations should be performed by trained service personnel. When working on heating equipment, observe precautions in the literature, on tags, and on labels attached to the unit.

Follow all safety codes. Wear safety glasses and work gloves. Have fire extinguisher available.

Recognize safety information. This is the safety-alert symbol . When you see this symbol on the furnace and in instructions or manuals, be alert to the potential for personal injury.

Understand the signal words DANGER, WARNING, and CAUTION. These words are used with the safety-alert symbol. DANGER identifies the most serious hazards which **will** result in severe personal injury or death. WARNING signifies a hazard which **could** result in personal injury or death. CAUTION is used to identify unsafe practices which **may** result in minor personal injury or product and property damage. NOTE is used to highlight suggestions which **will** result in enhanced installation, reliability, or operation.

WARNING

FIRE, EXPLOSION AND ELECTRICAL SHOCK HAZARD

Failure to follow this warning could result in personal injury, death and/or property damage
Before beginning any installation or modification, be sure the main electrical disconnect switch is in the OFF position.

CAUTION

UNIT DAMAGE HAZARD

Failure to follow this caution may result in improper and dangerous operation.
Label all wires prior to disconnection when servicing controls.

INTRODUCTION

→ This instruction covers installation of the high output permanent split capacitor (PSC) inducer motor kit Part No. 320725-754 and 320725-755 on models 340MAV, 340AAV, 345MAV, 350MAV, 350AAV, 490AAV, 58MCA, 58MCB, 58MSA, 58MXA, 58MXB, PG9MAA and PG9MAB Condensing Gas Furnaces. See Table 1 for kit applicability.

DESCRIPTION AND USAGE

Use this PSC inducer motor kit to replace a failed inducer motor assembly.

This kit contains the following items:

Inducer assembly	1
Installation Instructions	1

NOTE: Inducer assembly consists of motor and fan, capacitor, wheel, motor mount, inducer cover, inducer housing, vent cap, and vent clamp.

INSTALLATION

Step 1—Remove Old Motor Assembly

1. Turn off gas and electrical supplies to unit.
2. Remove main furnace door.
3. Disconnect vent pipe from inducer housing by loosening coupling clamp on vent pipe. Move pipe out of furnace casing.
4. Remove drain tube from inducer motor mounting cover plate.
5. Remove pressure switch tubes. (See Fig. 1.)
 - a. Remove tube attached to pressure switch from collector box.
 - b. Remove tube attached to pressure switch from burner enclosure and gas valve.
6. Remove screw securing pressure switch and capacitor to inducer housing.
7. Disconnect motor lead connector from quick-connect.
8. Remove 4 bolts attaching inducer housing assembly to heat exchanger cell panel.

Step 2—Install New Motor Assembly

1. Inspect seal on collector box. (See Fig. 2.)

→ **NOTE:** If collector box seal is damaged in any way, it must be repaired. To repair, apply sealant releasing agent such as PAM cooking spray or equivalent (must not contain corn or canola oil, halogenated hydrocarbons or aromatic contents to prevent inadequate sealing) to inducer housing. Apply a small bead of G.E. RTV 162, G.E. 6702, or Dow-Corning RTV 738 sealant to groove in collector box. G.E. 162 (P771-9003) is available through RCD in 3-oz. tubes.

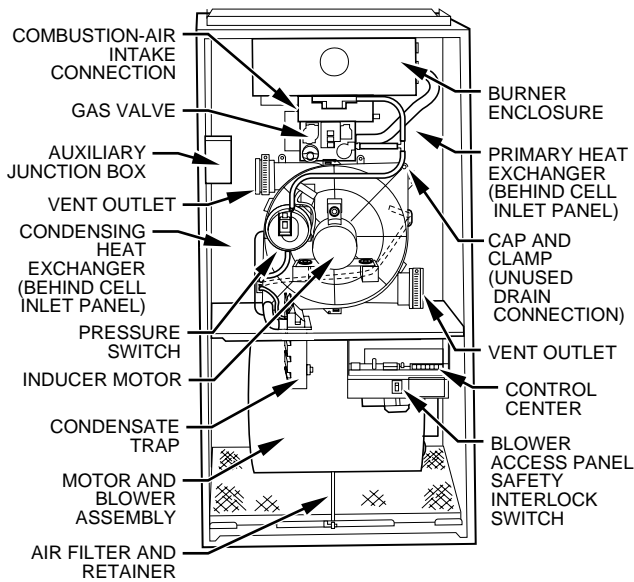

A98401

NOTE: Actual component location may vary depending on model and series.

Fig. 1—Inducer Motor Assembly in Upflow Furnace Orientation

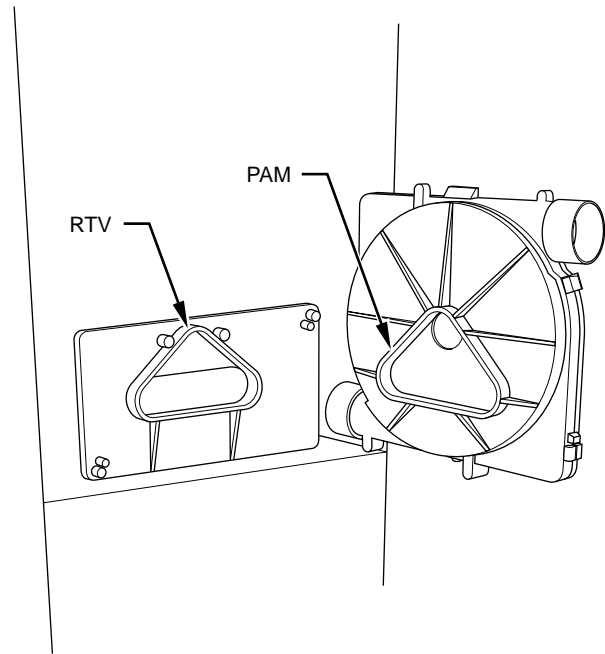

A93081

Fig. 2—Inducer Housing to Collector Box Gasket

→ **Table 1—Kit Usage**

KIT PART NO.	UNIT													
	340MAV 350MAV 490AAV		345MAV		340AAV 350AAV		58MCA 58MXA		58MSA		58MCB 58MXB		PG9MAA PG9MAB	
	Size	Series	Size	Series	Size	Series	Size	Series	Size	Series	Size	Series	Size	Series
320725-754	060120	D and Later Series	060120	A and Later Series	060120	A and Later Series	120-20	130 and Later Series	120-20	100 and Later Series	120-20	100 and Later Series	060120	A and Later Series
320725-755	060140	D and Later Series	—	—	060140	A and Later Series	140-20	130 and Later Series	—	—	140	100 and Later Series	060140	A and Later Series

NOTE: For all other sizes and series, use PSC inducer motor housing assembly kit, Part No. 320725-753.

2. Remove 4 bolts and spacers from old inducer housing assembly.
3. Install spacers in new inducer housing.
4. Insert bolts through inducer housing.

NOTE: Inserting bolts at this time will add to the ease of their installation later.

5. Install new inducer housing assembly to heat exchanger cell panel by aligning guide pins in collector box.

NOTE: Do not pinch collector box pressure tube when assembling inducer housing to collector box.

6. Tighten 4 bolts securing inducer housing assembly to heat exchanger cell panel.
7. Remove screw securing capacitor and reuse to secure pressure switch and capacitor to inducer motor mounting cover plate.
8. Reconnect pressure switch tubes. See tubing label on furnace for proper connections.
 - a. Connect tube from burner enclosure and gas valve to pressure switch.
 - b. Connect tube from collector box to pressure switch.
9. Reconnect motor leads to quick-connect.
10. Reconnect drain tube to inducer motor mounting cover plate.

11. Remove cap and clamp from unused drain connection on old inducer motor mounting cover plate and install on new inducer motor mounting cover plate.
- 12. Connect vent pipe by inserting pipe through elastomeric (rubber) coupling and then fully into inducer housing outlet. Tighten coupling clamp screw(s) to 15 in.-lb of torque.

⚠ WARNING

FIRE, EXPLOSION AND ELECTRICAL SHOCK HAZARD

Failure to follow this warning could result in personal injury, death and/or property damage. After completing installation, vent pipe must be installed and fully seated against inducer housing internal stop. Coupling clamp screw(s) must be tightened to 15 in.-lb of torque to prevent disassembly of vent from furnace, and to prevent vent gas and condensate leakage.

13. Turn on gas and electrical supplies to unit.
14. Check for gas leaks.

⚠ WARNING

**FIRE, EXPLOSION AND ELECTRICAL SHOCK
HAZARD**

Failure to follow this warning could result in personal injury, death and/or property damage.

Never use matches, candles, flame, or other sources of ignition to check for gas leakage. Use a soap-and-water solution.

15. Check furnace operation through 2 complete cycles.

16. Reinstall main furnace door.

Manufacturer reserves the right to discontinue, or change at any time, specifications or designs without notice and without incurring obligations.