

# Two-Speed Inducer Assembly Kit

Cancels: IIK 352M-60-1

IIK 352M-60-9  
8-05

## Installation Instructions Part No. 326058-751, -752, -753, -754

**NOTE:** Read the entire instruction manual before starting the installation.

This symbol → indicates a change since the last issue.

### SAFETY CONSIDERATIONS

Installing and servicing of heating equipment can be hazardous due to gas and electrical components. Only trained personnel should install or service heating equipment.

Untrained personnel can perform basic maintenance functions such as cleaning coils or cleaning and replacing filters. All other operations should be performed by trained service personnel. When working on heating equipment, observe precautions in the literature, on tags, and on labels attached to the unit.

Follow all safety codes. Wear safety glasses and work gloves. Have fire extinguisher available.

Recognize safety information. This is the safety-alert symbol . When you see this symbol on the furnace and in instructions or manuals, be alert to the potential for personal injury.

Understand the signal word DANGER, WARNING, and CAUTION. These words are used with the safety-alert symbol. DANGER identifies the most serious hazards which **will** result in severe personal injury or death. WARNING signifies a hazard which **could** result in personal injury or death. CAUTION is used to identify unsafe practices which **may** result in minor personal injury or product and property damage. NOTE is used to highlight suggestions which **will** result in enhanced installation, reliability, or operation.

### WARNING

#### FIRE, EXPLOSION AND ELECTRICAL SHOCK HAZARD

Failure to follow this warning could result in personal injury and/or death.

Turn off gas and electrical supplies to unit before beginning any installation or modification. Follow operating instructions on label attached to furnace.

### CAUTION

#### UNIT DAMAGE HAZARD

Failure to follow this caution may result in improper and dangerous operation.

Label all wires prior to disconnection when servicing controls.

→ Table 1—Kit Usage

KIT PART NUMBER	UNIT	
	352MAV 352AAV	58MTA 58MTB
<b>326058-751</b>	036060	060-12
<b>326058-752</b>	036080 048080	080-12 080-16
<b>326058-753</b>	048100 060100	100-16 100-20
<b>326058-754</b>	060120	120-20

### INTRODUCTION

→ This instruction covers installation of the permanent split capacitor (PSC) two-speed motor inducer assembly kit Part No. 326058-751, -752, -753, -754 on models 352MAV, 352AAV, 58MTA, and 58MTB two-stage Condensing Gas Furnaces. See Table 1 for kit applicability.

### DESCRIPTION AND USAGE

Use this PSC two-speed inducer assembly kit to replace a failed inducer motor assembly.

This kit contains the following items:

Inducer assembly	1
Installation Instructions	1

**NOTE:** Inducer assembly consists of motor and fan, capacitor, wheel, motor mount, inducer cover, inducer housing, vent cap, and vent clamp.

### INSTALLATION

#### Step 1—Remove Old Motor Assembly

1. Turn off gas and electrical supplies to unit.
2. Remove main furnace door.
3. Remove drain tube from inducer motor mounting cover plate.
4. Remove pressure switch tubes. (See Fig. 1.)
  - a. Remove tube attached to pressure switch from collector box.
  - b. Remove tube attached to pressure switch from burner enclosure and gas valve.
5. Remove screws securing pressure switches to inducer housing.
6. Disconnect motor lead connector at quick-connect.
7. Disconnect vent pipe from inducer housing by loosening coupling clamp on inducer outlet. If coupling has 2 clamps, loosen clamp on vent pipe side. Move pipe out of furnace casing.

Manufacturer reserves the right to discontinue, or change at any time, specifications or designs without notice and without incurring obligations.

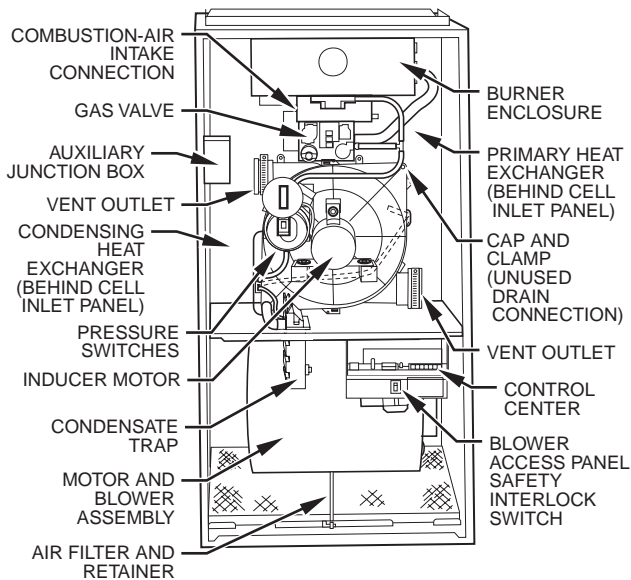

**Fig. 1—Inducer Motor Assembly in Upflow Furnace Orientation** <sup>A01026</sup>

8. Using backup wrench, disconnect gas supply pipe from gas valve.
9. Remove wires from gas valve. Note location for reassembly.
10. Remove burner enclosure cover.
11. Remove screws securing manifold to burner enclosure.
12. Remove manifold, orifices, and gas valve as 1 assembly.
13. Remove 4 bolts attaching inducer housing assembly to heat exchanger cell panel.

**Step 2—Install New Motor Assembly**

1. Inspect seal on collector box. (See Fig. 2.)

→ **NOTE:** If a collector box is damaged in any way, it must be repaired. To repair, apply sealant releasing agent such as PAM cooking spray or equivalent (must not contain corn nor canola oil, halogenated hydrocarbons, nor aromatic content to prevent inadequate sealing) to inducer housing. Apply a small bead of G.E. RTV 162, G.E. 6702, or Dow-Corning RTV 738 sealant to groove in collector box. G.E. 162 (P771-9003) is available through RCD in 3-oz. tubes.

2. Remove 4 bolts and spacers from old inducer housing assembly.
3. Install spacers in new inducer housing.
4. Insert bolts through inducer housing.

**NOTE:** Inserting bolts at this time will add to the ease of their installation later.

5. Install new inducer housing assembly to heat exchanger cell panel by aligning guide pins in collector box.

**NOTE:** Do not pinch collector box pressure tube when assembling inducer housing to collector box.

6. Tighten 4 bolts securing inducer housing assembly to heat exchanger cell panel.
7. Secure pressure switches to inducer motor mounting cover plate using mounting screw from old assembly.

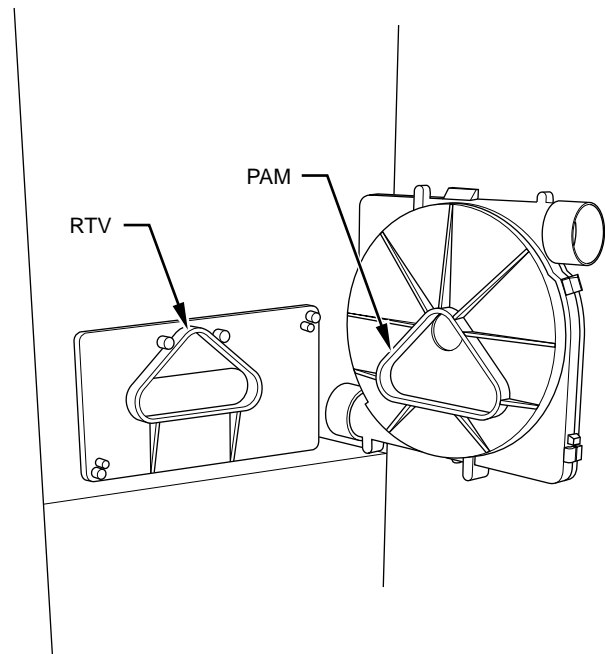

**Fig. 2—Inducer Housing to Collector Box Gasket** <sup>A93081</sup>

8. Reconnect pressure switch tubes. See tubing label on furnace for proper connections.
  - a. Connect tube from burner enclosure and gas valve to pressure switch.
  - b. Connect tube from collector box to pressure switch.
9. Reconnect motor leads to quick-connect.
10. Reconnect drain tube to inducer motor mounting cover plate.
11. Remove cap and clamp from unused drain connection on old inducer motor mounting cover plate and install on new inducer motor mounting cover plate.
- 12. Connect vent pipe by inserting through elastomeric (rubber) coupling and then fully into inducer housing outlet. Tighten coupling clamp screw(s) to 15 in.-lb of torque.

<b>⚠ WARNING</b>
<b>FIRE AND EXPLOSION HAZARD</b>
Failure to follow this warning could result in personal injury, death, and/or property damage.
After completing installation, vent pipe must be installed and fully seated against inducer housing internal stop. Coupling clamp screw(s) must be tightened to 15 in.-lb of torque to prevent disassembly of vent from furnace, and to prevent vent gas and condensate leakage.

13. Reinstall manifold assembly with gas valve to burner box. Replace mounting screws.
14. Replace burner box cover.
15. Using backup wrench, reconnect gas supply pipe to gas valve to prevent rotation and improper orientation.

**NOTE:** Use propane gas resistant pipe dope to prevent gas leaks. DO NOT use Teflon tape.

**⚠ WARNING**

**FIRE AND EXPLOSION HAZARD**

Failure to follow this warning could result in personal injury, death and/or property damage.

Gas valve switch or knob **MUST** be facing forward or tilted upward.

16. Reconnect wires to gas valve. Refer to furnace wiring diagram for proper wire location.
17. Turn on gas and electrical supplies to unit.
18. Check for gas leaks.

**⚠ WARNING**

**FIRE AND EXPLOSION HAZARD**

Failure to follow this warning could result in a fire, personal injury, death and/or property damage.

Never use matches, candles, flame, or other sources of ignition to check for gas leakage. Use a soap-and-water solution.

19. Check furnace operation through 2 complete cycles.
20. Reinstall main furnace door.

---

**Manufacturer reserves the right to discontinue, or change at any time, specifications or designs without notice and without incurring obligations.**