

COMFORT™ 92 MODEL 58MXB
HIGHLY-EFFICIENT 4-WAY MULTIPOISE FIXED-CAPACITY
DELUXE CONDENSING GAS FURNACE
Input Rates: 40,000 thru 138,000 Btuh

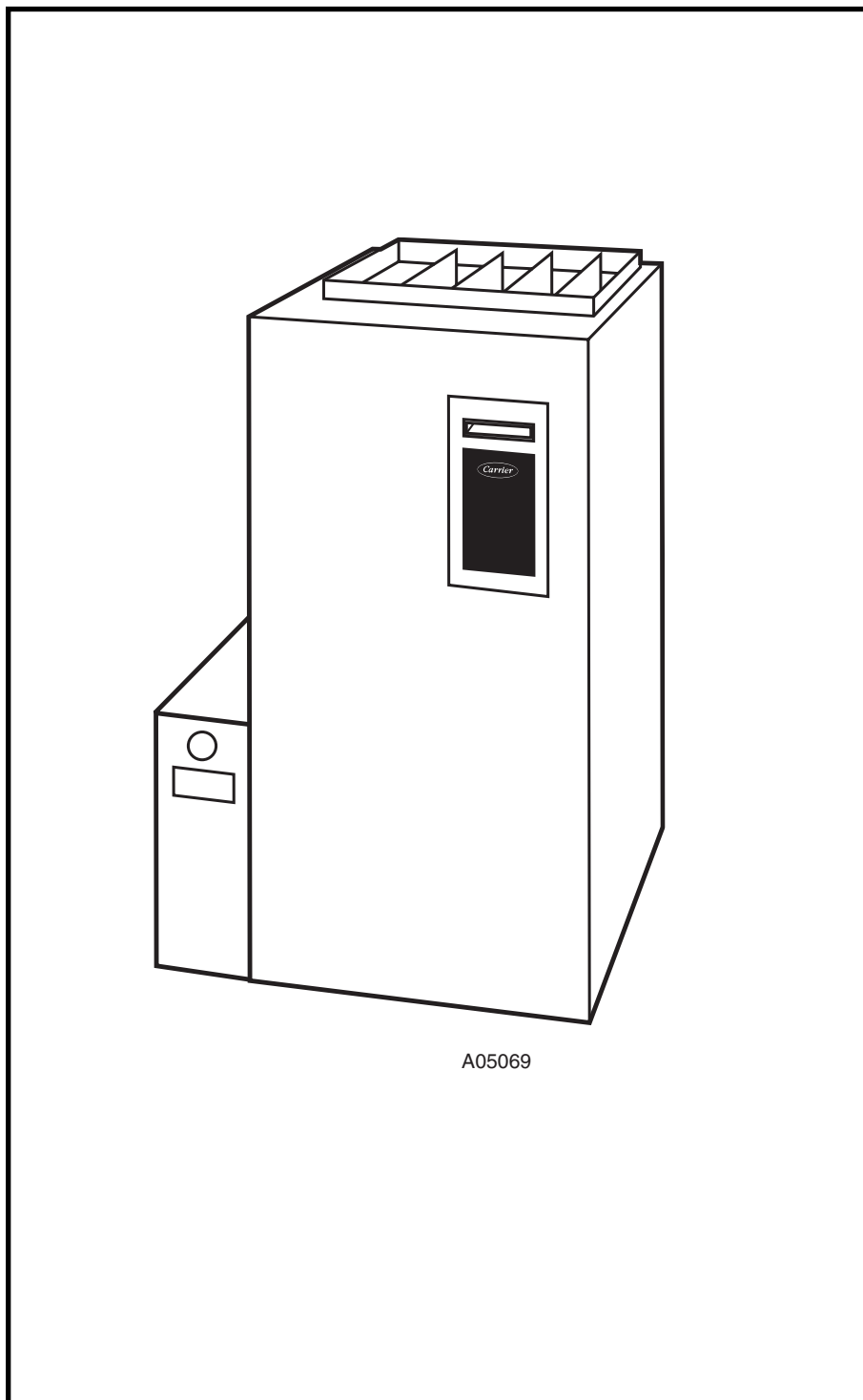

Turn to the Experts.™

Product Data



4-Way Multipoise Design Allows More Applications . . .

The Comfort™ 92 is a must for your product line. This high-efficiency furnace allows more applications with its reliable 4-way multipoise design. The Comfort™ 92 is available in 12 heat/air-flow combinations and with the 4-way multipoise design can be installed in upflow, downflow, or horizontal positions covering up to 48 different applications. With the exception of the 140 size unit, all Comfort™ 92 models can be installed in a manufactured (mobile) home when the optional kit is used, and in installations with elevations up to 10,000 ft (140 size unit limitation 7,000 ft). The furnace is factory configured for upflow application. With the exception of the 140 size, all sizes can be installed with 2-pipe or 1-pipe venting. The 140 size can be installed only as a 2-pipe system.

This versatile unit utilizes Power Heat™ hot surface ignition (HSI) which ignites the burners directly. HSI eliminates gas waste that typical continuous-pilot designs can bring. Hot surface ignition provides reliable start-up and operation.

Take a look at the control center on the Comfort™ 92. Control of ignition, inducer, and blower operation is all handled in 1 central printed circuit board. The status indicator on the control signals when a fault has occurred and identifies where the problem is. This, along with the component test feature, makes the Comfort™ 92 one of the easiest gas furnaces to troubleshoot.

High efficiency is achieved by maximizing heat transfer. The result is energy-saving efficiency, up to 95.5 percent Annual Fuel Utilization Efficiency (AFUE), and reduced operational noise. The Comfort™ 92 is one of the quietest furnaces in the industry.

A unique feature of this unit is the patented polypropylene-laminated heat exchanger. This secondary heat exchanger ensures that all available heat is properly transferred to the airstream

and throughout the home. Using the exclusive flow-through design, the secondary heat exchanger reduces the pressure drop in the furnace which leads to lower electrical usage, an important part of this unit's efficiency. Carrier heat exchangers are backed by a Limited Lifetime Warranty. (See Warranties section for details.)

When we put it all together, the Comfort™ 92 combines quality and design to bring high efficiency and comfort. You will enjoy the versatility and ease of installation of this unit. The Comfort™ 92 is equipped for either left- or right-side connections. Blower speeds are easily adjustable with speed-taps conveniently located on the control center. A combustion inducer allows for more use of 2-in. vent and combustion-air piping, keeping installation costs low.

As with other Carrier furnaces, this model is designed to work as a part of the total home comfort system which includes elements for cooling, air cleaning, humidification, ventilation, and zoning.

Comfort™ 92 FEATURES/ BENEFITS

Serpentuff™ — Exclusive Serpentuff coating, a patented polypropylene laminate is used on the secondary heat exchanger.

Power Heat™ Igniter — Carrier's unique SiN igniter is not only physically robust but it is also electrically robust. It is capable of running at line voltage and does not require complex voltage regulators as do other brands. This unique feature further enhances the reliability of Comfort™ 92 gas furnace and continues Carrier's tradition of technology leadership and innovation in providing a reliable and durable product.

ComfortFan™ — Improves comfort all year long by allowing the homeowner to select different fan speeds during continuous fan operation to achieve more or

less airflow. This is done right at the thermostat.

SmartEvap™ — This feature allows your system to reduce summertime humidity levels by nearly 10% over standard systems.

Media Filter Cabinet — Enhanced indoor air quality in your home is made easier with our media filter cabinet—a standard accessory on all Deluxe furnaces. When installed as a part of your system, this cabinet allows for easy and convenient addition of a Carrier high-efficiency air filter.

Control Center — Microprocessor controls sequencing and furnace operation. Equipped with a component test feature and status indicator light to assist in troubleshooting. Microprocessor blower control times blower start after main burners ignite to eliminate cold air blowing into rooms.

Warranties — Limited Lifetime Warranty on the heat exchangers for the lifetime of original owner in single family residence; 20 years in other residential and commercial applications. Five-year Limited Warranty on entire unit. Contact your dealer for details.

Direct or Non-direct Venting — The Comfort™ 92 can be installed as a 1 pipe/Non-Direct vent (except 140 size unit and in manufactured/mobile home installations) or 2 pipe/Direct vent furnace. This provides added flexibility to meet diverse installation needs.

Insulated Blower Compartment — The acoustical insulation reduces air and motor noise to promote quiet operation.

Combustion Products Venting — The combustion-air and vent pipes can terminate through a side wall or through the roof when used with a factory-authorized vent termination kit.

Insulation — Foil-faced insulation in heat exchanger section of the casing

minimizes heat loss.

Bottom Closure — Factory-installed for side return; easily removable for bottom return.

Filter — Cleanable filter with retainer is standard.

Blower Access Panel Switch — Shuts off all 115-v power through furnace components whenever blower access panel is opened.

Casing — One piece, seamless wrap-around construction of heavy, galvanized steel resists corrosion.

Adjustable Blower Speed — For precise airflow selection of heating or cooling operation.

Monoport Burners — The burners are finely tuned for smooth, quiet combustion plus economical gas usage.

Slow Opening Redundant Gas Valve — Shuts off gas to burners if 1 of the valves fails to close completely for any reason. The slow opening feature reduces start-up noise from rapid ignition.

Quality Registration — The Comfort™ 92 is engineered and manufactured under an ISO 9001 registered quality system.

Certifications — The Comfort™ 92 Model units are CSA (A.G.A. and C.G.A.) design certified for use with natural and propane gases. The furnace is factory-shipped for use with natural gas. A CSA (A.G.A./C.G.A.) listed gas conversion kit is required to convert furnace for use with propane gas. The efficiency is GAMA efficiency rating certified. The Comfort™ 92 meets California Air Quality Management District emission requirements. Except for the 140 size unit, all Comfort™ 92 models can be installed in a manufactured (mobile) home when the optional kit is used in direct vent (2-pipe) application. Refer to Vent Table, for elevation limitations.

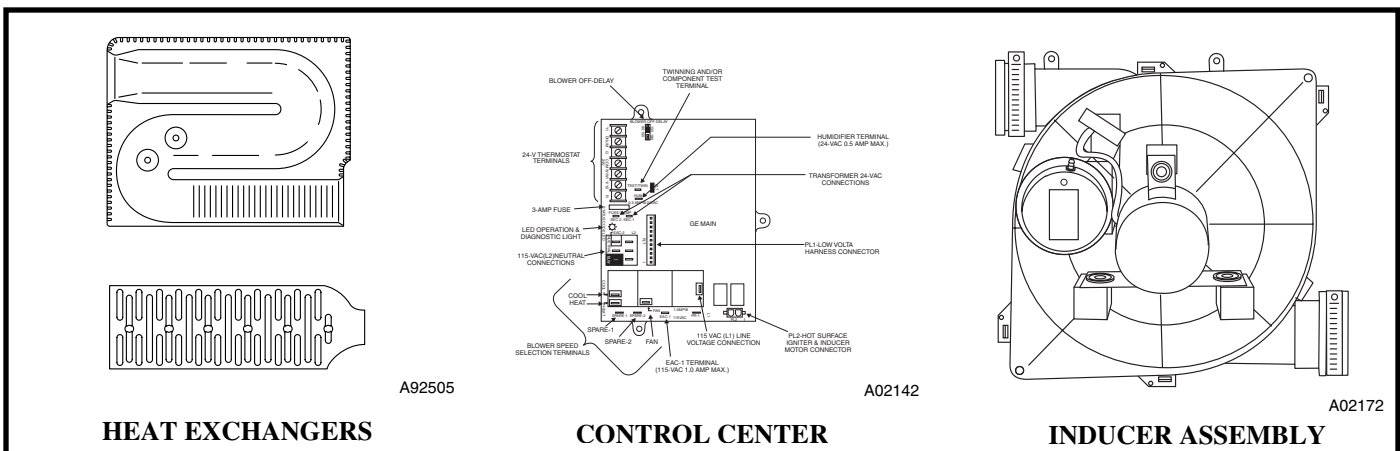

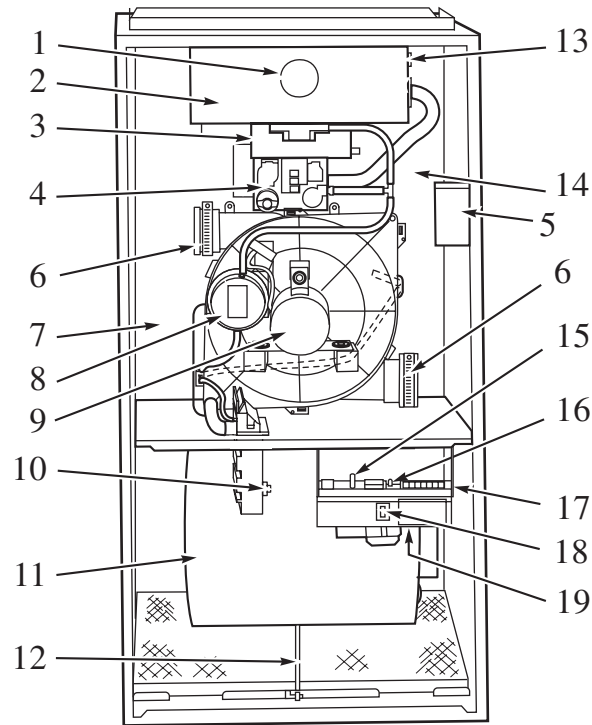

A02173

- 1** Burner sight glass for viewing burner flame.
- 2** Burner assembly (inside), operates with energy-saving, inshot burners and hot surface igniter for safe, dependable heating.
- 3** Combustion-air intake connection to ensure contaminant-free air (right or left side).
- 4** Redundant gas valve, safe, efficient, features 1 gas control with 2 internal shutoff valves.
- 5** Junction box for 115-v electrical power supply. (right or left side)
- 6** Vent outlet uses sealed PVC pipe to carry vent gases from the furnace's combustion system (right or left side).
- 7** Secondary condensing heat exchanger (inside), wrings out more heat through condensation of gases. Constructed with Polypropylene-laminated steel to ensure durability.
- 8** Pressure switch ensures adequate flow of flue products through furnace and out vent system.
- 9** Inducer motor pulls hot flue gases through the heat exchangers, maintaining negative pressure for added safety.
- 10** Condensate drain connection collects moisture condensed during the combustion process.
- 11** Heavy-duty blower circulates air across the heat exchangers to transfer heat into the home.
- 12** Air filter and retainer may be used for side or bottom return application.
- 13** Rollout switch (manual reset) to prevent overtemperature in burner area.
- 14** Primary serpentine heat exchanger (inside). Stretches fuel dollars with the S-shaped heat-flow design. Solid weld-free construction of corrosion-resistant aluminized steel means reliability.
- 15** 3-amp fuse provides electrical and component protection.
- 16** Light emitting diode (LED) on control center. Code lights are for diagnosing furnace operation and service requirements.
- 17** Control center.
- 18** Blower access panel safety interlock switch.
- 19** Transformer (24v) behind control center provides low-voltage power to furnace control center and thermostat.

Model number nomenclature

58MXB

58MXB

040

F

100

08

Deluxe 4-Way Multipoise Fixed-Capacity Direct-Vent (2-pipe) and Non-Direct Vent (1-pipe) Condensing Gas Furnace

Input Rates

040 — 40,000 Btuh	100 — 100,000 Btuh
060 — 60,000 Btuh	120 — 120,000 Btuh
080 — 80,000 Btuh	140 — 138,000 Btuh

Cooling Airflow
(Nominal 400 CFM per 12,000 Btuh Cooling)
08 — 800 CFM
12 — 1200 CFM
16 — 1600 CFM
20 — 2000 CFM

Series

Media Filter Cabinet included



MEETS DOE RESIDENTIAL CONSERVATION SERVICES PROGRAM STANDARDS

Before purchasing this appliance, read important energy cost and efficiency information available from your retailer.



As an ENERGY STAR® Partner, Carrier Corporation has determined that this product meets the ENERGY STAR® guidelines for energy efficiency.

ISO 9001:2000



REGISTERED QUALITY SYSTEM

These products are engineered and manufactured under an ISO 9001 registered quality system.

Physical data

UNIT SIZE	040-08	040-12	060-08	060-12	060-16	080-12	080-16	080-20	100-16	100-20	120-20	140-20
SHIPPING WEIGHT (Lb)	174	175	180	182	183	198	205	214	229	232	261	261
LIMIT CONTROL	SPST											
HEATING BLOWER CONTROL (Off Delay)	Selectable 90, 120, 150, or 180 Sec.											
BURNERS (Monoport)	2	2	3	3	3	4	4	4	5	5	6	6
GAS CONNECTION SIZE	1/2-in. NPT											
GAS VALVE (Redundant) Manufacturer	White-Rodgers											
Minimum Inlet Pressure (In. wc)	4.5 (Natural Gas)											
Maximum Inlet Pressure (In. wc)	13.6 (Natural Gas)											
IGNITION DEVICE	Hot Surface											

UNIT SIZE	040-08	040-12	060-08	060-12	060-16	080-12	080-16	080-20	100-16	100-20	120-20	140-20
DIRECT-DRIVE MOTOR h.p. (PSC)	1/5	1/3	1/5	1/3	1/2	1/3	1/2	3/4	1/2	3/4	3/4	3/4
MOTOR FULL LOAD AMPS	4.9	5.8	4.9	5.8	7.9	5.8	7.9	11.1	7.9	11.1	11.1	11.1
RPM (Nominal) — SPEEDS	1075—3	1075—4	1075—3	1075—4								
BLOWER WHEEL DIAMETER X WIDTH (In.)	10 x 6	10 x 7	10 x 6	10 x 7	11 x 8	10 x 7	11 x 8	11 x 10	11 x 8	11 x 10	11 x 10	11 x 10
FILTER SIZE (In.) — (Washable)	(1) 16 x 25 x 1							(1) 20 x 25 x 1			(1) 24 x 25 x 1	

PSC—Permanent Split Capacitor

Carrier accessories*

58MXB

UNIT SIZE	040-08 040-12	060-08 060-12 060-16	080-12 080-16 080-20	100-16 100-20	120-20	140-20
GAS CONVERSION KIT — NATURAL-TO-PROPANE	KGANP4001ALL					
GAS CONVERSION KIT — PROPANE-TO-NATURAL	KGAPN3301ALL					
TWINNING KIT	N/A	KGATW0601HSI†				N/A
MANUFACTURED (Mobile) HOME KIT	KGAMH0102KIT					N/A
DOWNFLOW BASE (For Combustible Floors)‡	KGASB0201ALL					
VENT TERMINATION KIT (Bracket Only for 2 Pipes)	2-in. — KGAVT0101BRA		3-in. — KGAVT0201BRA			
CONCENTRIC TERMINATION KIT (Single Exit)	2-in. — KGAVT0501CVT		3-in. — KGAVT0601CVT			
CONDENSATE FREEZE PROTECTION KIT	KGAHT01010CFP					
CONDENSATE NEUTRALIZER KIT (obtained thru RCD)	P908-0001					
ELECTRONIC AIR CLEANER (EAC)	Model EACB					
MECHANICAL AIR CLEANER	Model FILCAB, EZXCAB					
HUMIDIFIER	Models HUM					
HEAT RECOVERY VENTILATOR	Model HRV					
ENERGY RECOVERY VENTILATOR	Model ERV					
UV LIGHTS	Model UVL					
VENT/EXHAUST PIPE EXTERNAL TRAP KIT	KGAET0106ETK					
DOOR GASKET KIT	KGBAC0110DGK					

* Factory-authorized and field-installed. Gas conversion kits are CSA (A.G.A./C.G.A.) recognized.

† For 16 and 20 airflow sizes only (except 140-20 size unit). See kit Installation Instructions for details.

‡ Required for installation on combustible floors when no coil box is used, or when any coil box other than a Carrier cased coil is used.

Thermostat and zoning control options

Non-Programmable Thermostat Selection

TSTATCCNAC01-C	For use with 1-spd. Air Conditioner - deg. F/C, Auto Changeover
TSTATCCNHP01-C	For use with 1-spd. Air Conditioner - deg. F/C, Auto Changeover
TSTATCCN2S01-C	For use with 2-spd. Air Conditioner - deg. F/C, Auto Changeover
TSTATCCBAC01-B	For use with 1-spd. Air Conditioner - deg. F/C
TSTATCCPRH01-B**	For multi-use / stage configurations - deg. F/C, Auto Changeover/Temperature and Humidity Control

* Model HP and 2S thermostat must be field converted to air conditioner operation.

**Thermidistat Control is versatile and can be configured for multiple use and staging, it must be configured for each specific application.

Programmable Thermostat Selection

TSTATCCPAC01-B	For use with 1-spd. Air Conditioner - deg. F/C, Auto Changeover, 7-Day Programmable
TSTATCCPHP01-B*	For use with 1-spd. Air Conditioner - deg. F/C, Auto Changeover, 7-Day Programmable
TSTATCCP2S01-B*	For use with 2-spd. Air Conditioner - deg. F/C, Auto Changeover, 7-Day Programmable
TSTATCCSAC01	For use with 1-spd. Air Conditioner - deg. F/C, 5-2 Day Programmable
TSTATCCPDF01-B**	For use with multi-stage applications - deg. F/C, Auto Changeover, 7-Day Programmable
TSTATCCPRH01-B***	For multi-use / stage configurations - deg. F/C, Auto Changeover, 7-Day Programmable/Temperature and Humidity Control

* Model HP and 2S thermostat must be field converted to air conditioner operation.

**Dual Fuel thermostat is used with furnace and heat pump application

***Thermidistat Control can be configured for multiple use and staging, it must be configured for each specific application.

Zoning Control Selection

ZONECC3Z(AC/HP)01	Weather Maker Two-Zone kit
ZONECC2KIT01-B	Comfort Zone <i>Plus</i> 2-Zone kit/Temperature and Humidity Control
ZONECC4KIT01-B	Comfort Zone <i>Plus</i> 4-Zone kit/Temperature and Humidity Control
ZONECC8KIT01-B	Comfort Zone <i>Plus</i> 8-Zone kit/Temperature and Humidity Control

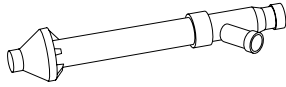

A93086

CONCENTRIC VENT (DIRECT VENT/ 2-PIPE ONLY)

A concentric vent kit allows vent and combustion-air pipes to terminate through a single exit in a roof or side wall.

One pipe runs inside the other allowing venting through the inner pipe and combustion air to be drawn in through the outer pipe.

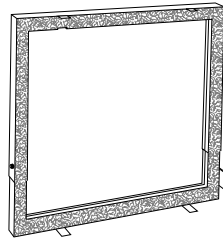

A88202

DOWNFLOW SUBBASE

One base fits all furnace sizes. The base is designed to be installed between the furnace and a combustible floor when no coil box is used or when a coil box other than a Carrier cased coil is used. It is CSA (A.G.A./C.G.A.) design certified for use with Carrier 58MXB furnaces when installed in downflow applications.

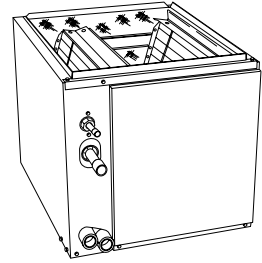

A96214

CARRIER CASED N-COIL (as shown)

The Carrier Cased N-Coil or A-Coil is an upflow/downflow furnace coil which can also replace the downflow subbase when installing the 58MXB on combustible flooring in the downflow orientation.

58MXB

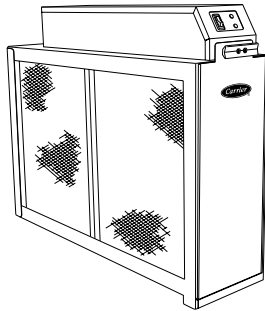

A97152

ELECTRONIC AIR CLEANER

Cleans the air of smoke, dirt, and many pollens commonly found. Saves decorating and cleaning expenses by keeping carpets, furniture, and drapes cleaner.

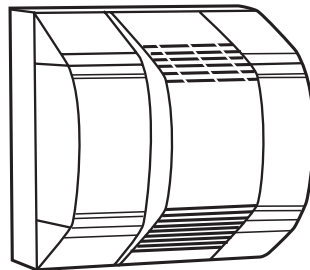

A01484

HUMIDIFIER

By adding moisture to winter-dry air, a Carrier humidifier can often improve comfort and keeps woodwork, wallpaper, and paint in better condition. Moisturizing household air also helps to retain normal body heat and provides comfort at lower temperatures.

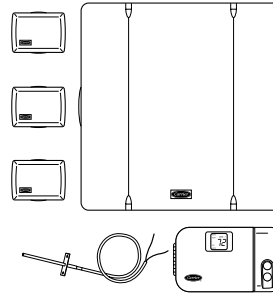

A97432

CONTROLS: THERMOSTATS AND ZONING

Available in programmable and non-programmable models, Carrier thermostats maintain a constant, comfortable temperature level in the home.

For the ultimate in home comfort, Carrier's 2, 4, and 8-zone systems allow temperature control of individual zones of the home. This is accomplished through a series of electronic dampers and remote room sensors. The 4-zone system is shown.

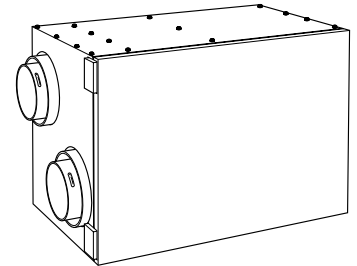

A94336

ENERGY/HEAT RECOVERY VENTILATOR

Carrier's energy or heat recovery ventilators exhaust stale indoor air and provide fresh outdoor air to the home while minimizing heat loss and humidity level. Especially useful for today's tighter constructed houses.

Energy recovery ventilator is shown.

Dimensions

58MXB

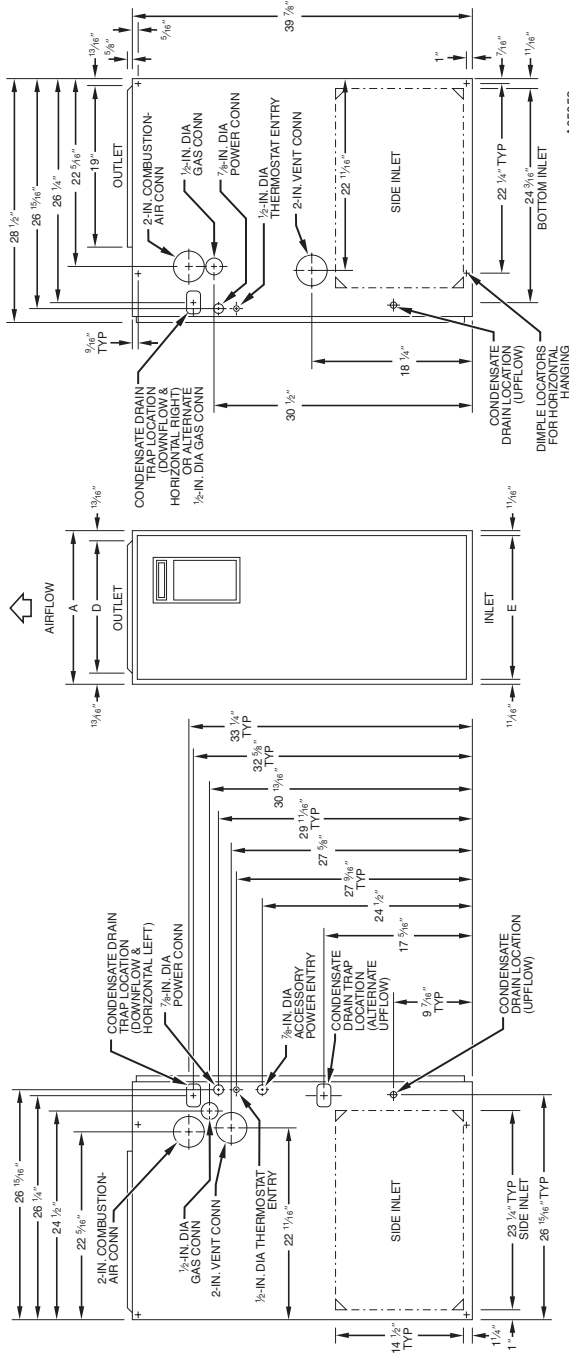

- NOTES:**
- Minimum return-air openings at furnace, based on metal duct. If flex duct is used, see flex duct manufacturer's recommendations for equivalent diameters.
 - Minimum return-air opening at furnace.
 - For 800 CFM, 6-in. round or 14 1/2 x 12-in. rectangle.
 - For 1200 CFM, 22-in. round or 14 1/2 x 23 1/2-in. rectangle.
 - For 1600 CFM, 22-in. round or 14 1/2 x 23 1/2-in. rectangle.
 - For airflow requirements above 1600 CFM, see Air Delivery table in Product Data literature for specific use of single side inlets. The use of both side inlets, a combination of 1 side and the bottom, or the bottom only ensure adequate return air openings for airflow requirements above 1600 CFM at 0.5" W.C. ESP.

A05053

DIMENSIONS (In.)

UNIT SIZE	A	D	E
040-08	17-1/2	15-7/8	16
040-12	17-1/2	15-7/8	16
060-08	17-1/2	15-7/8	16
060-12	17-1/2	15-7/8	16
060-16	17-1/2	15-7/8	16
080-12	17-1/2	15-7/8	16
080-16	17-1/2	15-7/8	16
080-20	21	19-3/8	19-1/2
100-16	21	19-3/8	19-1/2
100-20	21	19-3/8	19-1/2
120-20	24-1/2	22-7/8	23
140-20	24-1/2	22-7/8	23

DOWNFLOW SUBBASE — DIMENSIONS (In.)

FURNACE CASING WIDTH	FURNACE IN DOWNFLOW APPLICATION	PLENUM OPENING*		FLOOR OPENING		HOLE NO. FOR WIDTH ADJUSTMENT
		A	B	C	D	
17-1/2	Furnace with or without Cased Coil Assembly or Coil Box	15-1/8	19	16-3/4	20-3/8	3
21	Furnace with or without Cased Coil Assembly or Coil Box	18-5/8	19	20-1/4	20-3/8	2
24-1/2	Furnace with or without Cased Coil Assembly or Coil Box	22-1/8	19	23-3/4	20-3/8	1

* The plenum should be constructed 1/4 in. smaller in width and depth than the plenum dimensions shown above.

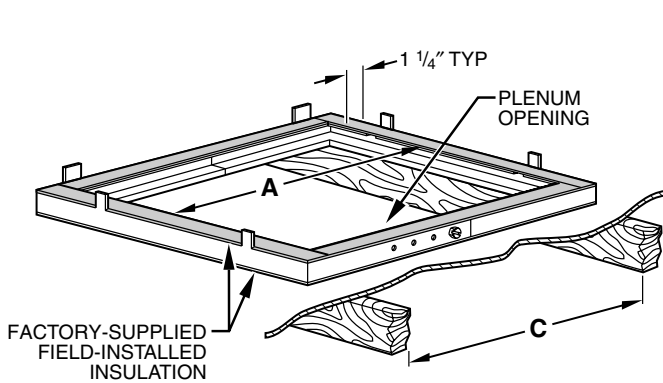

Assembled

A97427

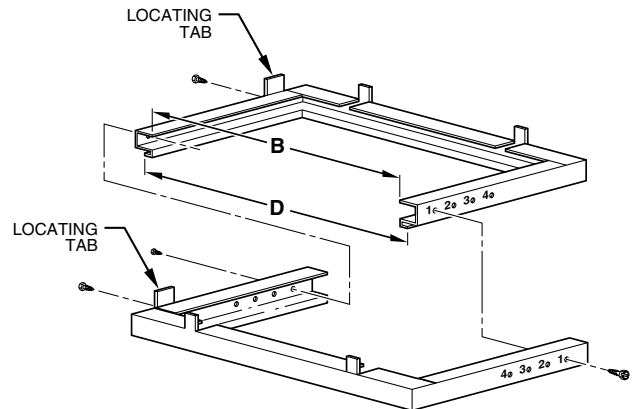

Disassembled

A88207

COMBUSTION-AIR PIPE FOR NON-DIRECT VENT (1-PIPE) APPLICATION (SIZES 040 THROUGH 120 ONLY)

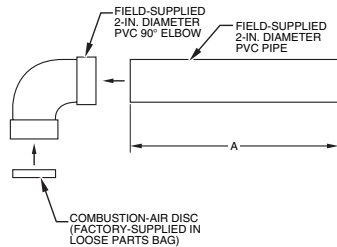

LENGTH OF STRAIGHT PIPE PORTION OF COMBUSTION AIR INLET PIPE ASSEMBLY (IN.)

CASING WIDTH	A
17-1/2	8-1/2 ± 1/2
21	10-1/2 ± 1/2
24-1/2	12 ± 1/2

CONCENTRIC VENT FOR DIRECT VENT (2-PIPE) APPLICATION (ALL MODEL SIZES)

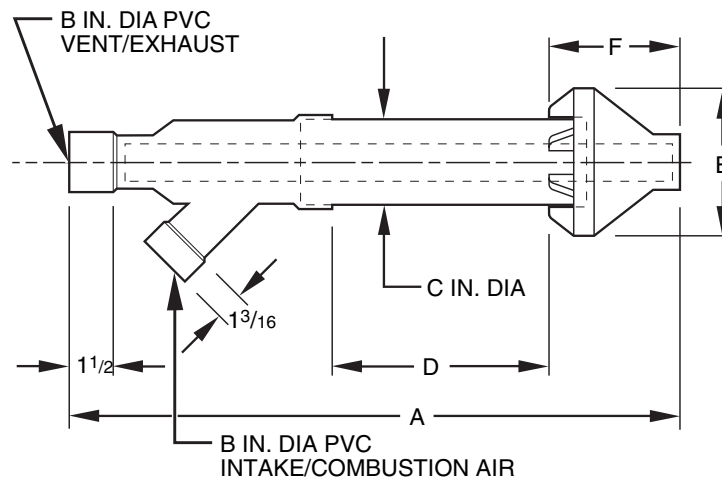

NOTE: See furnace Installation Instructions when venting multiple furnaces near each other.

A97110

DIMENSIONS (In.)

KIT PART NO.	A*	B	C	D†	E	F
KGAVT0501CVT	33-3/8	2	3-1/2	16-5/8	6-1/4	5-3/4
KGAVT0601CVT	38-7/8	3	4-1/2	21-1/8	7-3/8	6-1/2

* Dimension A will change accordingly as dimension D is lengthened or shortened.

† Dimension D may be lengthened to 60 in. maximum. Dimension D may also be shortened by cutting the pipes provided in the kit to 12 in. minimum.

CONDENSATE TRAP

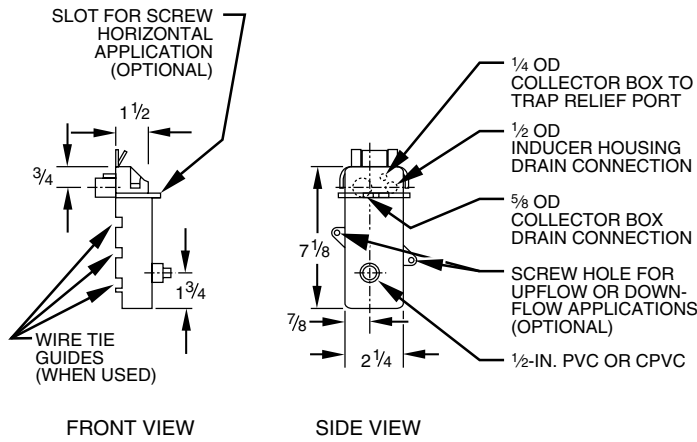
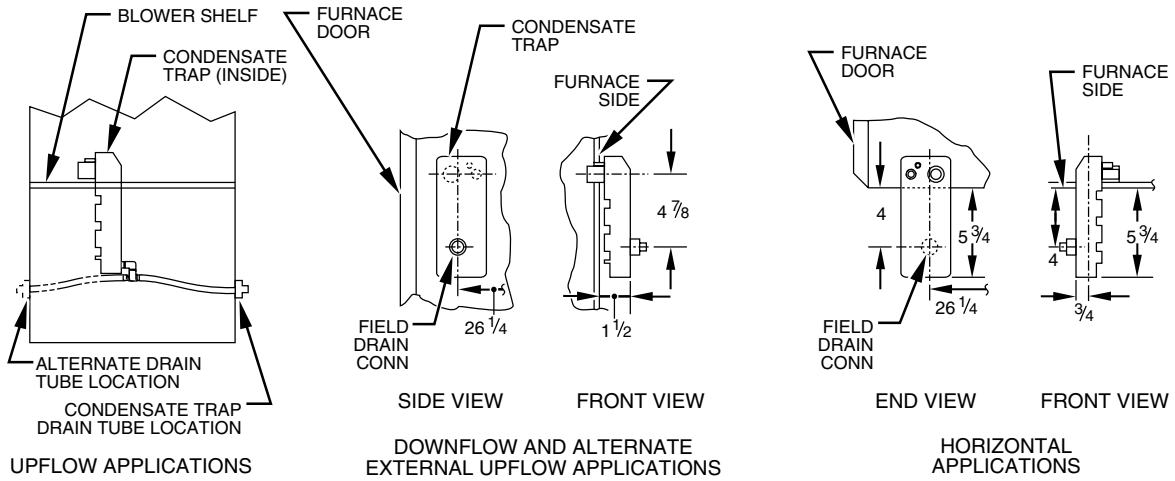

A93026

MEDIA FILTER CABINET

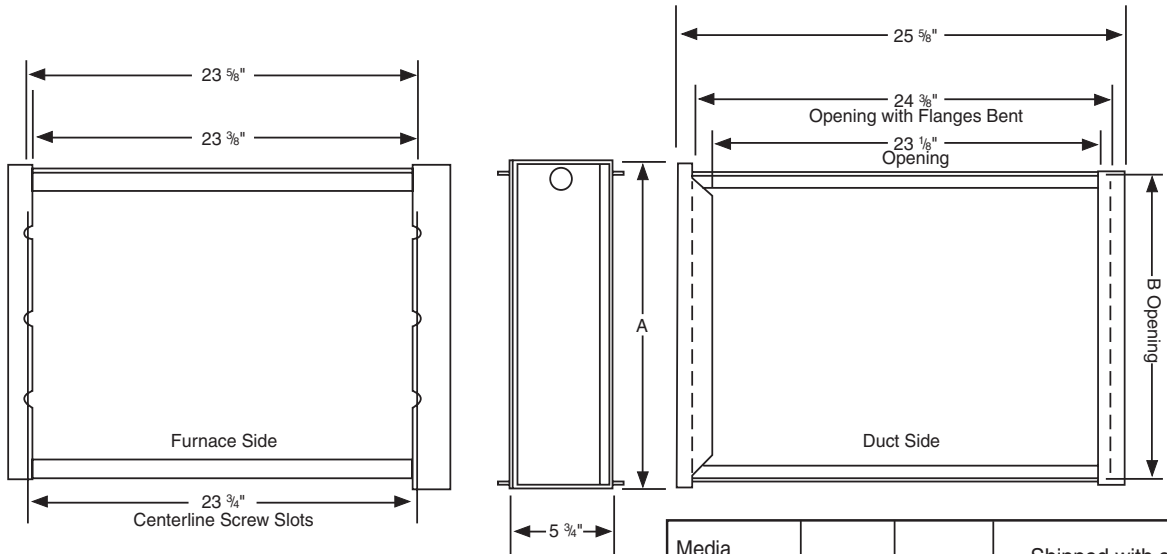

Media Filter Cabinet	A	B	Shipped with sizes
16"	17"	16"	040-08, 040-12, 060-08, 060-12, 060-16, 080-12, 080-16
20"	21"	20"	080-20, 100-16, 100-20
24"	25"	24"	120-20, 140-20

A05186

Clearance to combustibles

INSTALLATION

This forced air furnace is equipped for use with natural gas at altitudes 0 - 10,000 ft (0 - 3,050m), except 140 size Furnaces are only approved for altitudes 0 - 7,000 ft. (0 - 2,135m). An accessory kit, supplied by the manufacturer, shall be used to convert to propane gas use or may be required for some natural gas applications. This furnace is for indoor installation in a building constructed on site. This furnace may be installed in a manufactured (mobile) home when stated on rating plate and using factory authorized kit.

This furnace may be installed on combustible flooring in alcove or closet at minimum clearance from combustible material. This appliance requires a special venting system. Refer to the installation instructions for parts list and method of installation. This furnace is for use with schedule-40 PVC, PVC-DWV, CPVC, or ABS-DWV pipe, and must not be vented in common with other gas-fired appliances. Construction through which vent/air intake pipes may be installed is maximum 24 inches (600 mm), minimum 3/4 inches (19 mm) thickness (including roofing materials).

Cette fournaise à air pulsé est équipée pour utilisation avec gaz naturel et altitudes comprises entre 0 - 3,050m (0-10,000 pi), excepté queles fournaises de 140 taille sont pour altitudes comprises entre 0 - 2,135m (0 - 7,000 pi).

Utiliser une trousse de conversion, fournie par le fabricant, pour passer au gaz propane ou pour certaines installations au gaz naturel.

Cette fournaise à air pulsé est pour installation à l'intérieur dans un bâtiment construit sur place. Cette fournaise à air pulsé peut être installée dans une maison préfabriquée (maison mobile) si prescrit par la plaque signalétique et si l'on utilise une trousse spécifiée par le fabricant.

Cette fournaise peut être installée sur un plancher combustible dans un enfoncement ou un placard en observant les dégagements minimums avec les matériaux combustibles.

Cet appareil nécessite un système d'évacuation spécial. La méthode d'installation et la liste des pièces nécessaires figurent dans les instructions d'installation. Cette fournaise doit s'utiliser avec la tuyauterie des nomenclatures 40 PVC, PVC-DWV, CPVC, ou ABS-DWV et elle ne peut pas être ventilée conjointement avec d'autres appareils à gaz. Epaisseur de la construction au travers de laquelle il est possible de faire passer les tuyaux d'aération (admission/évacuation): 24 po (600 mm) maximum, 3/4 po (19 mm) minimum (y compris la toiture).

For upflow and downflow applications, furnace must be installed level, or pitched within 1/2" of level. For a horizontal application, the furnace must be pitched minimum 1/4" to maximum of 1/2" forward for proper drainage. See Installation Manual for IMPORTANT unit support details on horizontal applications.

Pour des applications de flux ascendant et descendant, la fournaise doit être installée de niveau ou inclinée à pas plus de 1/2" du niveau. Pour une application horizontale, la fournaise doit être inclinée entre minimum 1/4" et maximum 1/2" du niveau pour le drainage approprié. En cas d'installation en position horizontale, consulter les renseignements IMPORTANTS sur le support dans le manuel d'installation.

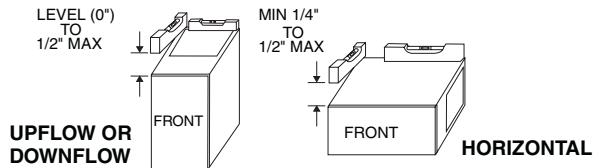

MINIMUM INCHES CLEARANCE TO COMBUSTIBLE CONSTRUCTION

ALL POSITIONS:

- * Minimum front clearance for service 30 inches (762mm).
- †† 140 size furnaces require 1 inch back clearance to combustible materials.

DOWNFLOW POSITIONS:

- † For installation on combustible floors only when installed on special base No. KGASB0201ALL, Coil Assembly, Part No. CD5 or CK5, or Coil Casing, Part No. KCAKC.

HORIZONTAL POSITIONS:

- Line contact is permissible only between lines formed by intersections of top and two sides of furnace jacket, and building joists, studs, or framing.
- § Clearance shown is for air inlet and air outlet ends.
- Ø 120 and 140 size furnaces require 1 inch bottom clearance to combustible materials.

DÉGAGEMENT MINIMUM EN POUCHES AVEC ÉLÉMENTS DE CONSTRUCTION COMBUSTIBLES

POUR TOUS LES POSITIONS:

- * Dégagement avant minimum de 762mm (30 po) pour l'entretien.
- †† Pour les fournaises de 140 taille, 1 po (25mm) dégagement des matériaux combustibles est requis au-arrière.

POUR LA POSITION COURANT DESCENDANT:

- † Pour l'installation sur le plancher combustible seulement quand on utilise la base spéciale, pièce n° KGASB0201ALL, l'ensemble serpent, pièce n° CD5 ou CK5, ou le carter de serpent, pièce n° KCAKC.

POUR LA POSITION HORIZONTALE:

- Le contact n'est permis qu'entre les lignes formées par les intersections du dessus et des deux côtés de la chemise de la fournaise, et des solives, des montants ou de la charpente du bâtiment.
- § La distance indiquée concerne l'extrémité du tuyau d'arrivée d'air et l'extrémité du tuyau de sortie d'air.
- Ø Pour les fournaises de 120 et 140 taille, 1 po (25mm) dégagement des matériaux combustibles est requis au-dessous.

This furnace is approved for UPFLOW, DOWNFLOW and HORIZONTAL installations.

Cette fournaise est approuvée pour l'installation HORIZONTALE et la circulation d'air VERS LE HAUT et VERS LE BAS.

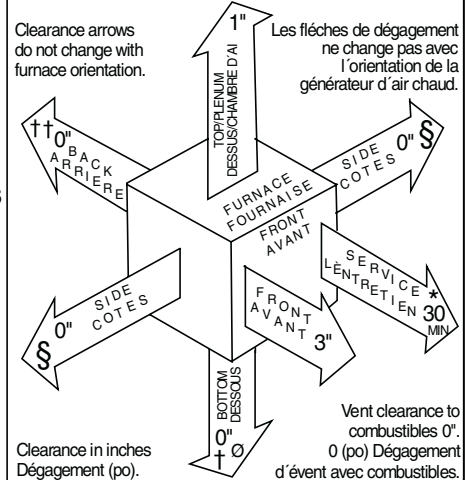

324999-201 REV. D (LIT TOP)

A02148

Performance data

EFFICIENCY

UNIT SIZE		040-08	040-12	060-08	060-12	060-16	080-12	080-16	080-20	100-16	100-20	120-20	140-20
CAPACITY* Direct Vent (2-Pipe) (Shaded capacities are specified on rating plate)	Upflow	38,000	38,000	56,000	56,000	56,000	75,000	75,000	75,000	94,000	94,000	113,000	129,000
	Downflow	38,000	38,000	56,000	56,000	56,000	75,000	75,000	75,000	94,000	94,000	113,000	129,000
	Horizontal	38,000	38,000	56,000	56,000	56,000	74,000	75,000	75,000	93,000	93,000	112,000	128,000
Non-Direct Vent (1-Pipe)	Upflow	38,000	38,000	56,000	56,000	56,000	75,000	75,000	75,000	94,000	94,000	112,000	NA
	Downflow	38,000	38,000	56,000	56,000	56,000	74,000	75,000	75,000	93,000	93,000	113,000	NA
	Horizontal	38,000	38,000	56,000	56,000	56,000	74,000	75,000	75,000	93,000	93,000	112,000	NA
AFUE* Direct Vent (2-Pipe)	Upflow	94.3	95.5	93.0	93.0	93.0	93.0	93.0	93.0	93.0	93.0	93.0	92.6
	Downflow	92.9	94	91.5	91.5	91.5	91.5	91.5	91.5	91.5	91.5	91.5	91.2
	Horizontal	93.7	94.9	92.3	92.3	92.3	92.3	92.3	92.3	92.3	92.3	92.3	92
AFUE* Non-Direct Vent (1-Pipe)	Upflow	93.9	95.1	92.4								NA	
	Downflow	92.5	93.7	91.4								NA	
	Horizontal	93.3	94.5	91.4								NA	
Input Btuh†		40,000	40,000	60,000	60,000	60,000	80,000	80,000	80,000	100,000	100,000	120,000	138,000

UNIT SIZE		040-08	040-12	060-08	060-12	060-16	080-12	080-16	080-20	100-16	100-20	120-20	140-20
CERTIFIED TEMP RISE RANGE (°F)		30—60	15—45	45—75	30—60	20—50	40—70	30—60	20—50	45—75	30—60	40—70	50—80
CERTIFIED EXT STATIC PRESSURE (In. wc)	Heating	0.10	0.10	0.12	0.12	0.12	0.15	0.15	0.15	0.20	0.20	0.20	0.20
	Cooling	0.50	0.50	0.50	0.50	0.50	0.50	0.50	0.50	0.50	0.50	0.50	0.50
AIRFLOW CFM‡	Heating	850	1125	885	1065	1320	1190	1285	1785	1315	1690	1720	1970
	Cooling	895	1215	900	1200	1545	1245	1525	1925	1570	1930	2000	1990

* Capacity and AFUE in accordance with U.S. Government DOE test procedures.

† Gas input ratings are certified for elevations to 2000 ft. For elevations above 2000 ft, reduce ratings 2% for each 1000 ft above sea level. In Canada, derate the unit 5% for elevations 2000 to 4500 ft above sea level.

‡ • Airflow shown is for bottom only return-air supply with factory supplied 1-in. washable filter(s).

• For air delivery above 1800 CFM, see Air Delivery table for other options.

• An airflow reduction of up to 7% may occur when using the factory-specified 4 5/16-inch wide, high efficiency media filter.

• For best furnace efficiency when using the 4 5/16-inch wide media filter, adjust the blower speed tap to near the mid-point of the rise range.

ICS—Isolated Combustion System.

AIR DELIVERY—CFM (With Filter)

UNIT SIZE	RETURN-AIR SUPPLY	SPEED	EXTERNAL STATIC PRESSURE (In. wc)							
			0.1	0.2	0.3	0.4	0.5	0.6	0.7	0.8
040-08	1 side or bottom	High	1075	1040	995	945	895	840	760	670
		Med-Low	850	825	780	740	685	635	560	480
		Low	740	700	650	620	565	515	455	385
040-12	1 side or bottom	High	1470	1415	1400	1285	1215	1120	995	890
		Med-High	1315	1280	1235	1180	1115	1035	930	825
		Med-Low	1125	1110	1085	1045	990	915	830	740
060-08	1 side or bottom	High	1100	1065	1005	945	900	805	730	610
		Med-Low	890	865	810	765	705	620	540	475
		Low	745	710	670	625	565	505	425	360
060-12	1 side or bottom	High	1430	1375	1325	1275	1200	1135	1040	935
		Med-High	1270	1260	1215	1160	1105	1035	950	850
		Med-Low	1070	1055	1045	1015	975	920	850	750
060-16	1 side or bottom	High	1700	1695	1640	1580	1545	1450	1380	1310
		Med-High	1500	1465	1435	1385	1355	1300	1250	1185
		Med-Low	1325	1295	1265	1230	1190	1150	1105	1050
080-12	1 side or bottom	High	1535	1470	1405	1330	1245	1160	1065	935
		Med High	1395	1350	1300	1225	1155	1080	985	880
		Med-Low	1200	1175	1125	1065	1030	970	890	780
080-16	1 side or bottom	High	1750	1685	1635	1575	1525	1445	1380	1310
		Med-High	1495	1455	1405	1355	1305	1250	1185	1120
		Med-Low	1310	1260	1225	1170	1125	1095	1040	980
080-20	1 side or bottom	High	2200	2175	2085	2025	1925	1820	1735	1635
		Med-High	2100	2025	1945	1865	1785	1700	1620	1540
		Med-Low	1815	1760	1720	1670	1620	1550	1480	1405
080-20	both sides or 1 side and bottom	High	2360	2280	2210	2130	2035	1960	1875	1790
		Med-High	1965	1925	1870	1830	1760	1710	1670	1575
100-16	1 side or bottom	High	1740	1705	1660	1615	1570	1500	1425	1355
		Med-High	1500	1470	1445	1410	1375	1330	1280	1210
		Med-Low	1340	1315	1300	1270	1235	1200	1140	1095
100-20	1 side or bottom	High	2250	2175	2090	2020	1930	1855	1760	1670
		Med-High	2020	1950	1900	1840	1790	1710	1640	1545
		Med-Low	1725	1690	1660	1630	1575	1520	1460	1370
100-20	both sides or 1 side and bottom	High	2360	2315	2265	2200	2130	2055	1965	1890
		Med-High	1960	1940	1930	1900	1850	1800	1740	1660
120-20	bottom only	High	2350	2250	2160	2070	2000	1885	1790	1635
		Med-High	2100	2015	1955	1875	1810	1710	1650	1540
		Med-Low	1770	1720	1675	1620	1575	1515	1450	1365
120-20	both sides or 1 side and bottom	High	2435	2360	2285	2220	2130	2050	1965	1875
		Med-High	2040	2000	1950	1905	1835	1790	1725	1650
140-20	bottom only	High	2255	2190	2115	2045	1965	1890	1800	1710
		Med-High	1985	1930	1890	1840	1780	1720	1645	1560
140-20	both sides or 1 side and bottom	High	2285	2210	2140	2065	1990	1910	1830	1745
		Med-High	2020	1970	1920	1870	1805	1730	1660	1590
		Med-Low	1675	1650	1620	1590	1560	1510	1450	1390
140-20	1 side only	High	2310	2255	2185	2120	2045	1965	1880	1800
		Med-High	1975	1945	1900	1860	1835	1775	1720	1640

58MXB

- ‡ Airflow shown is for bottom only return-air supply with factory supplied 1-in. washable filter(s).
- For air delivery above 1800 CFM, see Air Delivery table for other options.
- An airflow reduction of up to 7% may occur when using the factory-specified 4 5/16-inch wide, high efficiency media filter.
- For best furnace efficiency when using the 4 5/16-inch wide media filter, adjust the blower speed tap to near the mid-point of the rise range.
- For horizontal and downflow applications, use 1 side or bottom or bottom only as airflow reference.

Combustion-air and vent piping for Direct Vent/2-Pipe (All Sizes) and Non-Direct Vent/1-Pipe (Sizes 040 through 120 Only) Applications

Maximum Allowable Pipe Length (ft)

ALTITUDE (FT)	UNIT SIZE (BTUH)	DIRECT VENT (2-PIPE) ONLY		NON-DIRECT VENT (1-PIPE) ONLY	NUMBER OF 90° ELBOWS						
		TERMINATION TYPE	PIPE DIA (IN.)*	PIPE DIA (IN.)*	1	2	3	4	5	6	
0 to 2000	40,000	2 Pipe or 2-in Concentric	1	1	5	NA	NA	NA	NA	NA	NA
			1-1/2	1-1/2	70	70	65	60	60	55	
			2	2	70	70	70	70	70	70	
	60,000	2 Pipe or 2-in Concentric	1-1/2	1-1/2	20	15	10	5	NA	NA	
			2	2	70	70	70	70	70	70	
	80,000	2 Pipe or 2-in Concentric	1-1/2	1-1/2	10	NA	NA	NA	NA	NA	
			2	2	55	50	35	30	30	20	
			2-1/2	2-1/2	70	70	70	70	70	70	
	100,000	2 Pipe or 3-in Concentric	2	2	5	NA	NA	NA	NA	NA	
			2-1/2	2-1/2	40	30	20	20	10	NA	
			3	3	70	70	70	70	70	70	
	120,000	2 Pipe or 3-in. Concentric	2-1/2 one disk	2-1/2	10	NA	NA	NA	NA	NA	
			3†	NA	45	40	35	30	25	20	
			3† no disk	3†	70	70	70	70	70	70	
	138,000	2 Pipe or 3-in. Concentric	2-1/2 one disk	NA	5	NA	NA	NA	NA	NA	
			3† one disk	NA	40	35	30	25	20	15	
			3† no disk	NA	60	56	52	48	44	40	
			4† no disk	NA	70	70	70	70	70	70	
2001 to 3000	40,000	2 Pipe or 2-in Concentric	1-1/2	1-1/2	67	62	57	52	52	47	
			2	2	70	70	70	70	70	70	
	60,000	2 Pipe or 2-in Concentric	1-1/2	1-1/2	17	12	7	NA	NA	NA	
			2	2	70	67	66	61	61	61	
	80,000	2 Pipe or 2-in Concentric	2	2	49	44	30	25	25	15	
			2-1/2	2-1/2	70	70	70	70	70	70	
	100,000	2 Pipe or 3-in Concentric	2-1/2	2-1/2	35	26	16	16	6	NA	
			3	3	70	70	70	70	66	61	
	120,000	2 Pipe or 3-in. Concentric	3	NA	14	9	NA	NA	NA	NA	
			NA	3†	63	62	62	61	61	61	
			3† no disk	NA	70	70	63	56	50	43	
			4† no disk	4† no disk	70	70	70	70	70	70	
	138,000	2 Pipe or 3-in. Concentric	3† one disk	NA	20	15	10	5	NA	NA	
			3† no disk	NA	39	35	31	27	23	19	
			4† no disk	NA	70	70	70	70	70	70	
	3001 to 4000	40,000	2 Pipe or 2-in Concentric	1-1/2	1-1/2	64	59	54	49	48	43
				2	2	70	70	70	70	70	70
		60,000	2 Pipe or 2-in Concentric	1-1/2	1-1/2	16	11	6	NA	NA	NA
2				2	68	63	62	57	57	56	
80,000		2 Pipe or 2-in Concentric	2	2	46	41	28	23	22	13	
			2-1/2	2-1/2	70	70	70	70	70	70	
100,000		2 Pipe or 3-in Concentric	2-1/2	2-1/2	33	24	15	14	5	NA	
			3	3	70	70	70	66	61	56	
120,000		2 Pipe or 3-in. Concentric	3† no disk	NA	65	58	51	44	38	31	
			NA	3†	59	59	58	57	57	56	
			4† no disk	4† no disk	70	70	70	70	70	70	
138,000		2 Pipe or 3-in. Concentric	3† one disk	NA	11	6	NA	NA	NA	NA	
			3† no disk	NA	30	26	22	18	14	10	
			4† no disk	NA	70	70	70	70	70	70	

See notes at end of table

58MXB

Combustion-air and vent piping for Direct Vent/2-Pipe (All Sizes) and Non-Direct Vent/1-Pipe (Sizes 040 through 120 Only) Applications (continued)

Maximum Allowable Pipe Length (ft) (Continued)

ALTITUDE (FT)	UNIT SIZE (BTUH)	DIRECT VENT (2-PIPE) ONLY		NON-DIRECT VENT (1-PIPE) ONLY	NUMBER OF 90° ELBOWS					
		TERMINATION TYPE	PIPE DIA (IN.)*	PIPE DIA (IN.)*	1	2	3	4	5	6
4001 to 5000‡	40,000	2 Pipe or 2-in Concentric	1-1/2	1-1/2	60	55	50	45	44	39
			2	2	70	70	70	70	70	70
	60,000	2 Pipe or 2-in Concentric	1-1/2	1-1/2	15	10	5	NA	NA	NA
			2	2	64	59	58	53	52	52
	80,000	2 Pipe or 2-in Concentric	2	2	44	39	26	21	20	11
			2-1/2	2-1/2	70	70	70	70	70	70
	100,000	2 Pipe or 3-in Concentric	2-1/2	2-1/2	31	22	13	12	NA	NA
			3	3	70	70	67	62	57	52
	120,000	2 Pipe or 3-in. Concentric	3† no disk	NA	53	46	40	33	26	20
			NA	3†	56	55	54	53	52	52
			4† no disk	4† no disk	70	70	70	70	70	70
	138,000	2 Pipe or 3-in. Concentric	3† no disk	NA	21	17	13	9	5	NA
4† no disk			NA	69	64	59	54	49	44	
ALTITUDE (FT)	UNIT SIZE (BTUH)	DIRECT VENT (2-PIPE) ONLY		NON-DIRECT VENT (1-PIPE) ONLY	NUMBER OF 90° ELBOWS					
		TERMINATION TYPE	PIPE DIA (IN.)*	PIPE DIA (IN.)*	1	2	3	4	5	6
5001 to 6000‡	40,000	2 Pipe or 2-in Concentric	1-1/2	1-1/2	57	52	47	42	40	35
			2	2	70	70	70	70	70	70
	60,000	2 Pipe or 2-in Concentric	1-1/2	1-1/2	14	9	NA	NA	NA	NA
			2	2	60	55	54	49	48	47
	80,000	2 Pipe or 2-in Concentric	2	2	41	36	23	18	17	8
			2-1/2	2-1/2	70	70	70	70	70	70
	100,000	2 Pipe or 3-in Concentric	2-1/2	2-1/2	29	21	12	11	NA	NA
			3	3	70	67	62	57	52	47
	120,000	2 Pipe or 3-in. Concentric	3† no disk	NA	42	35	29	22	15	9
			NA	3†	53	52	50	49	48	47
			4† no disk	4† no disk	70	70	70	70	70	70
	138,000	2 Pipe or 3-in. Concentric	3† no disk	NA	12	8	NA	NA	NA	NA
4† no disk			NA	42	37	32	27	22	17	
ALTITUDE (FT)	UNIT SIZE (BTUH)	DIRECT VENT (2-PIPE) ONLY		NON-DIRECT VENT (1-PIPE) ONLY	NUMBER OF 90° ELBOWS					
		TERMINATION TYPE	PIPE DIA (IN.)*	PIPE DIA (IN.)*	1	2	3	4	5	6
6001 to 7000‡	40,000	2 Pipe or 2-in Concentric	1-1/2	1-1/2	53	48	43	38	37	32
			2	2	70	70	68	67	66	64
	60,000	2 Pipe or 2-in Concentric	1-1/2	1-1/2	13	8	NA	NA	NA	NA
			2	2	57	52	50	45	44	43
	80,000	2 Pipe or 2-in Concentric	2	2	38	33	21	16	15	6
			2-1/2	2-1/2	70	70	68	67	66	64
	100,000	2 Pipe or 3-in Concentric	2-1/2	2-1/2	27	19	10	9	NA	NA
			3	3	68	63	58	53	48	43
	120,000	2 Pipe or 3-in. Concentric	3† no disk	NA	31	24	18	11	NA	NA
			NA	3†	49	48	47	45	44	43
			4† no disk	4† no disk	70	70	70	70	67	62
	138,000	2 Pipe or 3-in. Concentric	4† no disk	NA	17	12	7	NA	NA	NA

See notes at end of table

58MxB

Combustion-air and vent piping for Direct Vent/2-Pipe (All Sizes) and Non-Direct Vent/1-Pipe (Sizes 040 through 120 Only) Applications (continued)

Maximum Allowable Pipe Length (ft) (Continued)

ALTITUDE (FT)	UNIT SIZE (BTUH)	DIRECT VENT (2-PIPE) ONLY		NON-DIRECT VENT (1-PIPE) ONLY	NUMBER OF 90° ELBOWS					
		TERMINATION TYPE	PIPE DIA (IN.)*	PIPE DIA (IN.)*	1	2	3	4	5	6
7001 to 8000‡	40,000	2 Pipe or 2-in Concentric	1-1/2	1-1/2	49	44	39	34	33	28
			2	2	66	65	63	62	60	59
	60,000	2 Pipe or 2-in Concentric	1-1/2	1-1/2	12	7	NA	NA	NA	NA
			2	2	53	48	46	41	40	38
	80,000	2 Pipe or 2-in Concentric	2	2	36	31	19	14	12	NA
			2-1/2	2-1/2	66	65	63	62	60	59
	100,000	2 Pipe or 3-in Concentric	2-1/2	2-1/2	25	17	8	7	NA	NA
			3	3	63	58	53	48	43	38
	120,000	2 Pipe or 3-in. Concentric	3† no disk	NA	20	13	7	NA	NA	NA
			NA	3†	46	44	43	41	40	38
138,000		4† no disk	4† no disk	61	56	51	46	41	36	
		NA								
ALTITUDE (FT)	UNIT SIZE (BTUH)	DIRECT VENT (2-PIPE) ONLY		NON-DIRECT VENT (1-PIPE) ONLY	NUMBER OF 90° ELBOWS					
		TERMINATION TYPE	PIPE DIA (IN.)*	PIPE DIA (IN.)*	1	2	3	4	5	6
8001 to 9000‡	40,000	2 Pipe or 2-in Concentric	1-1/2	1-1/2	46	41	36	31	29	24
			2	2	62	60	58	56	55	53
	60,000	2 Pipe or 2-in Concentric	1-1/2	1-1/2	11	6	NA	NA	NA	NA
			2	2	49	44	42	37	35	34
	80,000	2 Pipe or 2-in Concentric	2	2	33	28	17	12	10	NA
			2-1/2	2-1/2	62	60	58	56	55	53
	100,000	2 Pipe or 3-in Concentric	2-1/2	2-1/2	23	15	7	5	NA	NA
			3	3	59	54	49	44	39	34
	120,000	2 Pipe or 3-in. Concentric	3† no disk	NA	10	NA	NA	NA	NA	NA
			NA	3†	43	41	39	37	35	34
138,000		4† no disk	4† no disk	35	30	25	20	15	10	
		NA								
ALTITUDE (FT)	UNIT SIZE (BTUH)	DIRECT VENT (2-PIPE) ONLY		NON-DIRECT VENT (1-PIPE) ONLY	NUMBER OF 90° ELBOWS					
		TERMINATION TYPE	PIPE DIA (IN.)*	PIPE DIA (IN.)*	1	2	3	4	5	6
9001 to 10,000‡	40,000	2 Pipe or 2-in Concentric	1-1/2	1-1/2	42	37	32	27	25	20
			2	2	57	55	53	51	49	47
	60,000	2 Pipe or 2-in Concentric	2	2	45	40	38	33	31	29
			2	2	30	25	14	9	7	NA
	80,000	2 Pipe or 2-in Concentric	2-1/2	2-1/2	57	55	53	51	49	47
			2-1/2	2-1/2	21	13	5	NA	NA	NA
	100,000	2 Pipe or 3-in Concentric	3	3	54	49	44	39	34	29
			NA	3†	39	37	35	33	31	29
	120,000	2 Pipe or 3-in. Concentric	4† no disk	4† no disk	10	5	NA	NA	NA	NA
	138,000		NA							

*Disk usage-Unless otherwise specified, use perforated disk assembly (factory-supplied in loose parts bag). If one disk is stated, separate 2 halves of perforated disk assembly and use shouldered disk half. When using shouldered disk half, install screen side toward inlet box.

†Wide radius elbow.

‡Vent sizing for Canadian installations over 4500 ft (1370 m) above sea level are subject to acceptance by the local authorities having jurisdiction.

NA-Not Allowed; pressure switch will not make.

NOTES:

1. Do not use pipe size greater than those specified in table or incomplete combustion, flame disturbance, or flame sense lockout may occur.
2. Size both the combustion-air and vent pipe independently, then use the larger diameter for both pipes.
3. Assume two 45° elbows equal one 90° elbow. Wide radius elbows are desirable and may be required in some cases.
4. Elbows and pipe sections within the furnace casing and at the vent termination should not be included in vent length or elbow count.
5. The minimum pipe length is 5 ft for all applications.
6. Use 3-in. diameter vent termination kit for installations requiring 4-in diameter pipe.

58MXB

**MAXIMUM ALLOWABLE EXPOSED VENT PIPE LENGTH (FT) WITH AND WITHOUT INSULATION
IN WINTER DESIGN TEMPERATURE AMBIENT***

UNIT SIZE	WINTER DESIGN TEMPERATURE (°F)	MAX PIPE DIAMETER (IN.)	WITHOUT INSULATION	WITH 3/8-IN. OR THICKER INSULATION†
040-08 040-12	20	1-1/2	51	70
	0	1-1/2	28	70
	-20	1-1/2	16	70
060-08 060-12 060-16	20	2	65	70
	0	2	35	70
	-20	2	20	70
080-12 080-16 080-20	20	2-1/2	70	70
	0	2-1/2	47	70
	-20	2-1/2	28	70
100-16 100-20	20	3	70	70
	0	3	50	70
	-20	3	28	70
120-20	20	4	70	70
	0	4	48	70
	-20	4	23	70
140-20	20	4	70	70
	0	4	57	70
	-20	4	30	70

58MXB

* Pipe length (ft) specified for maximum vent pipe lengths located in unconditioned spaces. Vent pipes located in unconditioned space cannot exceed the total allowable pipe length as specified in Maximum Allowable Pipe Length table.

† Insulation thickness based on R value of 3.5 per in.

Electrical data

UNIT SIZE	040-08	040-12	060-08	060-12	060-16	080-12	080-16	080-20	100-16	100-20	120-20	140-20
UNIT VOLTS — HERTZ — PHASE	115—60—1											
OPERATING VOLTAGE RANGE (Min — Max)*	104—127											
MAXIMUM UNIT AMPS	6.1	7.3	6.1	7.1	9.5	7.6	10.0	14.1	10.2	14.8	14.6	14.3
UNIT AMPACITY†	8.4	10.0	8.4	9.8	12.8	10.4	13.4	18.4	13.5	19.3	19.1	18.8
MINIMUM WIRE SIZE	14	14	14	14	14	14	14	12	14	12	12	12
MAXIMUM WIRE LENGTH (Ft)‡	44	37	44	38	29	36	28	31	27	30	30	30
MAXIMUM FUSE OR CKT BKR (Amps)**	15	15	15	15	15	15	15	20	15	20	20	20
TRANSFORMER (24v)	40va											
EXTERNAL CONTROL POWER AVAILABLE	Heating	12va										
	Cooling	21va										
AIR CONDITIONING BLOWER RELAY	Standard											

* Permissible limits of the voltage range at which unit will operate satisfactorily.

† Unit ampacity =125% of largest operating component's full load amps plus 100% of all other potential operating components' (EAC, humidifier, etc.) full load amps.

‡ Length is as measured 1 way along wire path between unit and service panel for maximum 2% voltage drop.

** Time-delay type is recommended.

58MXB

Typical wiring schematic

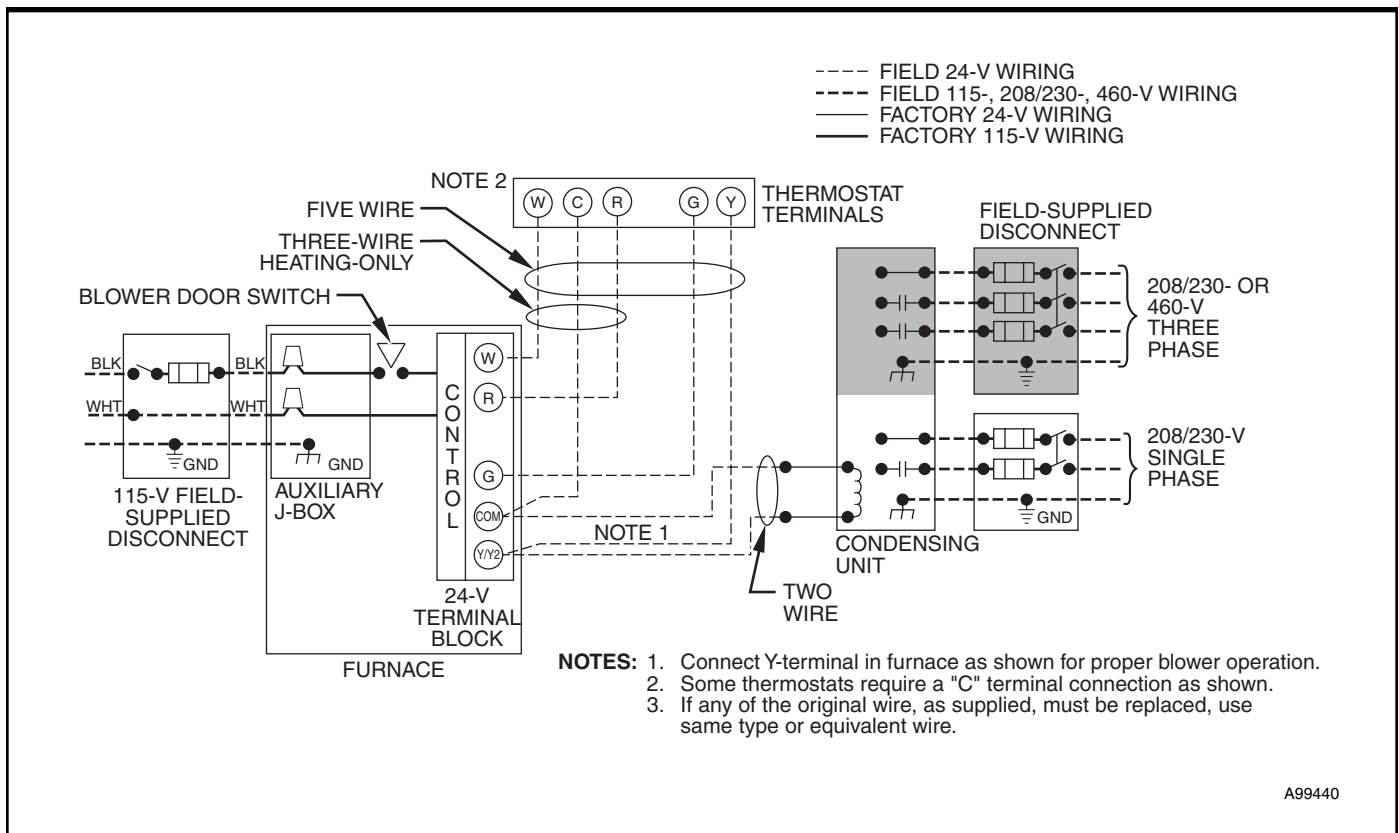

Typical installations

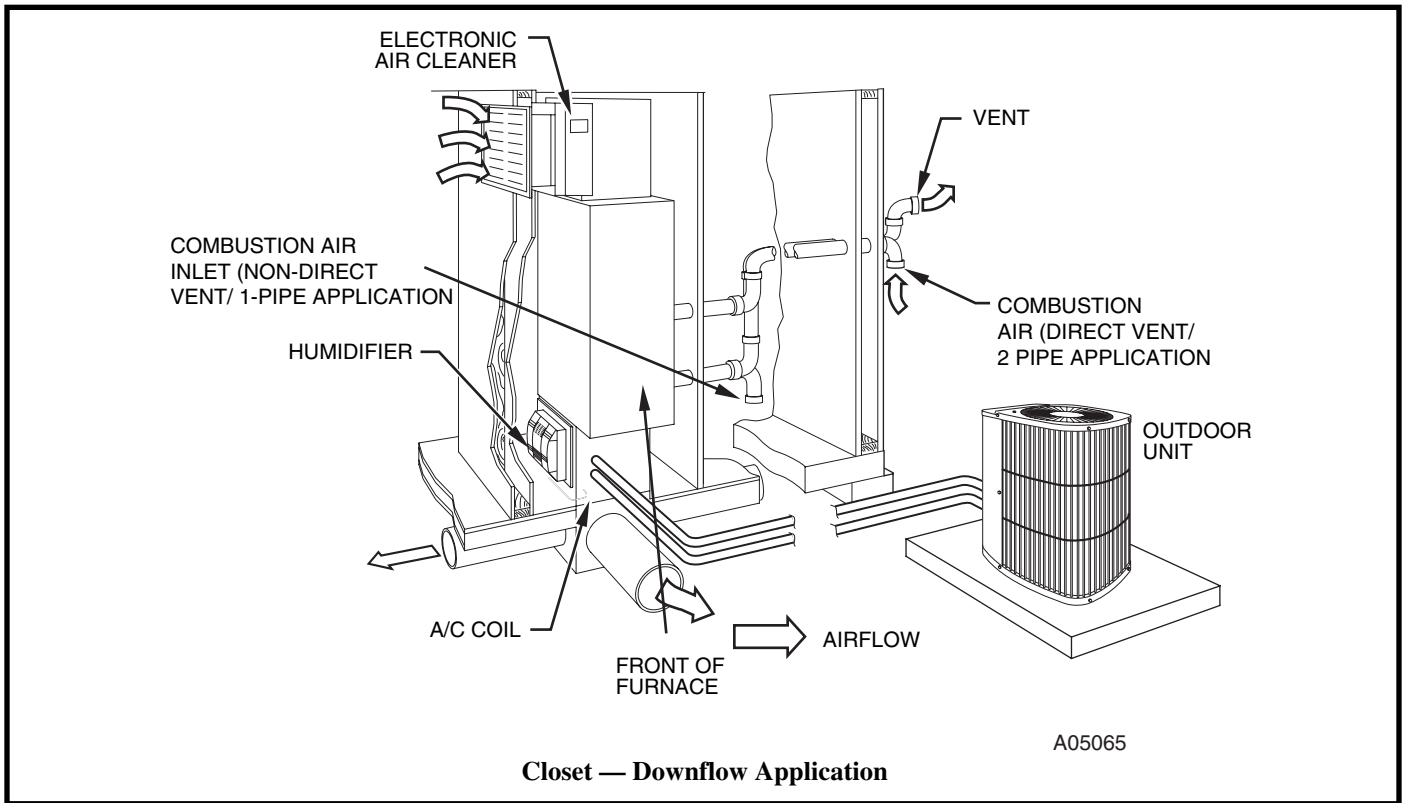
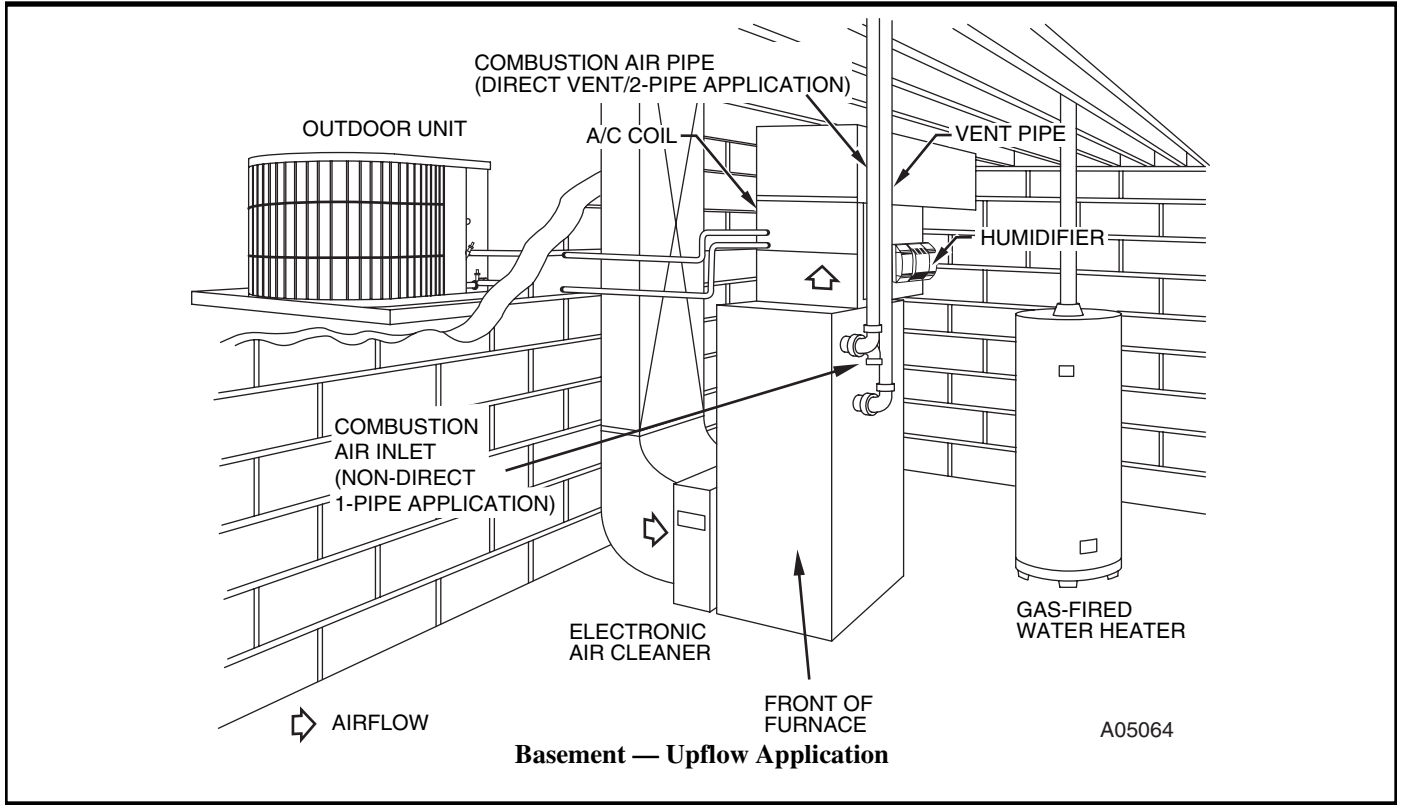

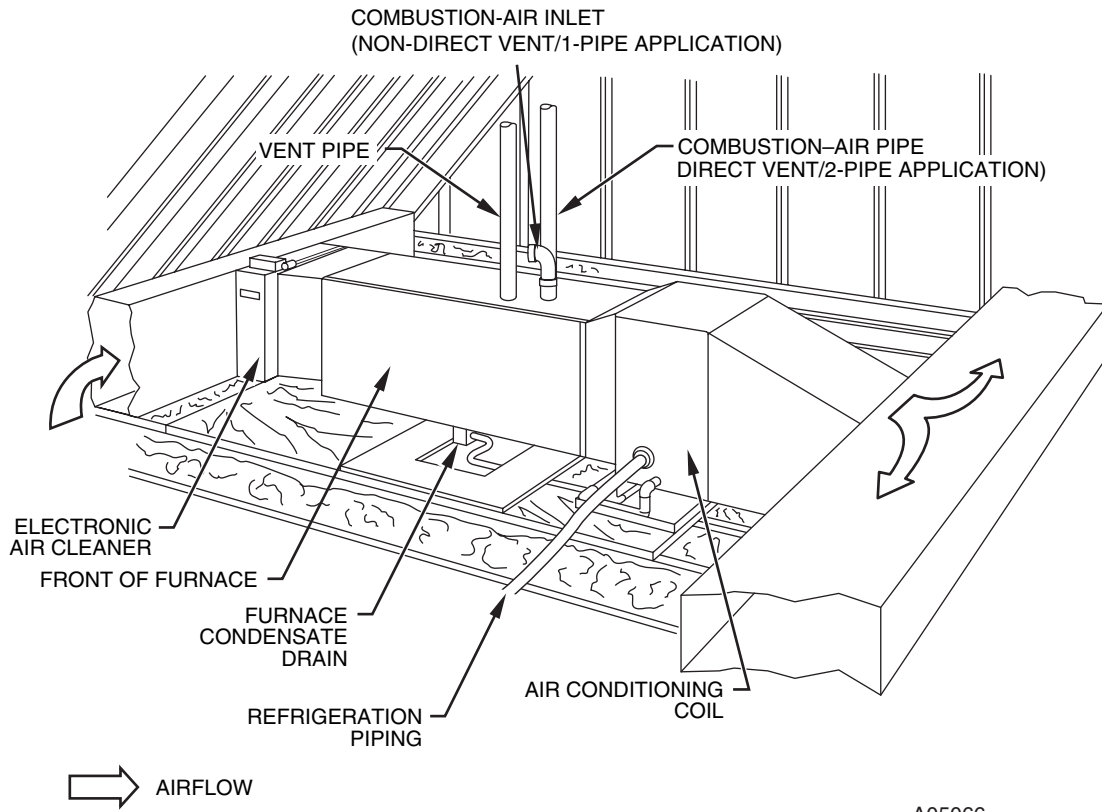

Attic — Horizontal Application

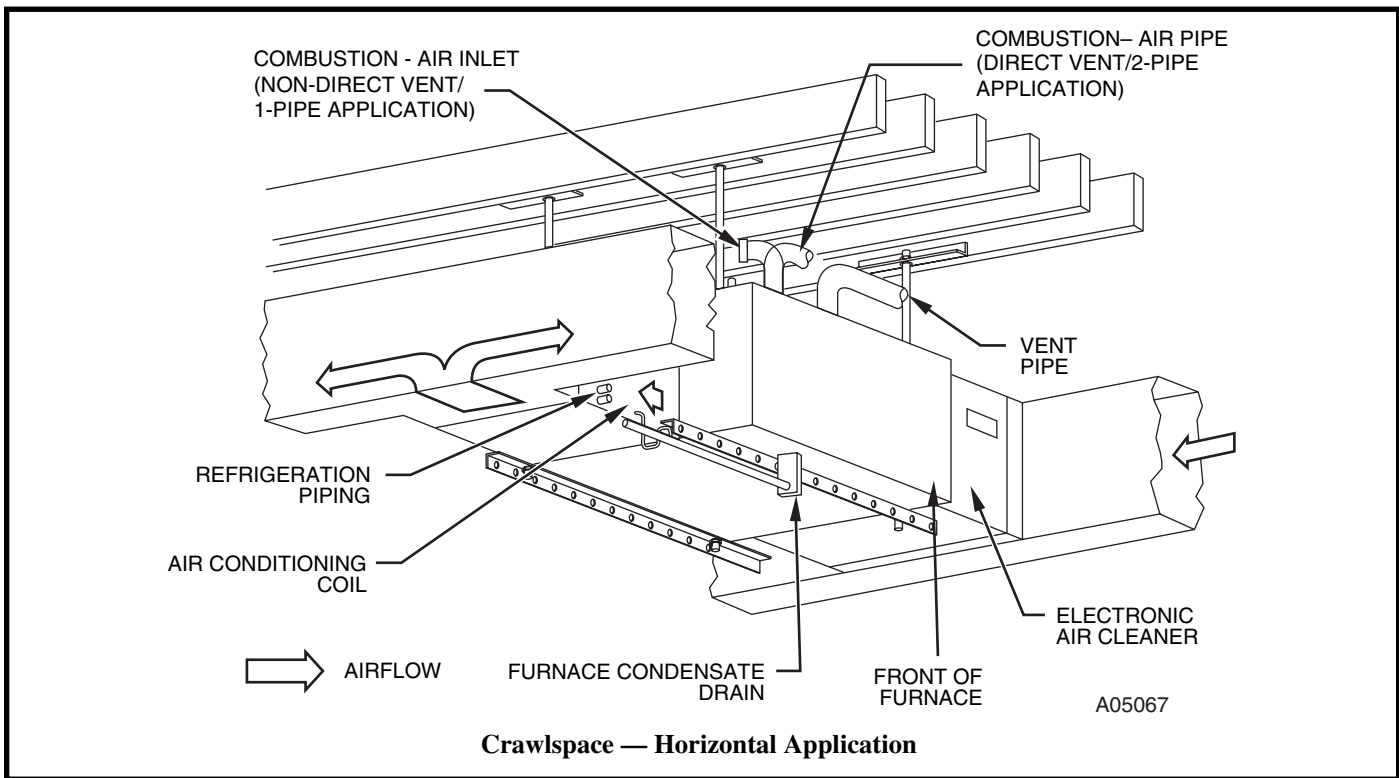

Crawlspace — Horizontal Application

Guide specifications

Comfort 92

Single-Stage/Deluxe Gas Furnace 58MXB

GENERAL

System Description

Furnish a _____ (4-way multipoise) fixed capacity gas-fired condensing furnace for use with natural gas or propane (factory authorized conversion kit required for propane); furnish cold air return plenum; furnish external medial cabinet for use with accessory media filter or standard filter.

Quality Assurance

Unit will be designed, tested and constructed to the current ANSI Z 21.47/CSA 2.3 design standard for gas-fired central furnaces.

Unit will be 3rd party certified by CSA to the current ANSI Z 21.47/CSA 2.3 design standard for gas-fired central furnaces.

Unit will carry the CSA Blue Star® and Blue Flame® labels.

Unit efficiency testing will be performed per the current DOE test procedure as listed in the Federal Register.

Unit will be certified for capacity and efficiency and listed in the latest GAMA Consumer's Directory of Certified Efficiency Ratings.

Unit will carry the current Federal Trade Commission Energy Guide efficiency label.

Delivery, Storage, and Handling

Unit will be shipped as single package only and is stored and handled per unit manufacturer's recommendations.

Warranty (for inclusion by specifying engineer)

U.S. and Canada only. Warranty certificate available upon request.

PRODUCTS

Equipment

Components shall include: slow-opening gas valve to reduce ignition noise, regulate gas flow, with electric switch gas shut-off; flame proving sensor, hot surface igniter, pressure switch assembly verifies inducer operation; flame rollout switch, drain tubing and installed condensate drain trap, blower and inducer assembly, 40va transformer; low-voltage (heating) (heating/cooling) thermostat.

Blower Wheel and Blower Motor

Galvanized blower wheel shall be centrifugal type, statically and dynamically balanced. Blower motor of PSC type shall be permanently lubricated with sealed bearings, of _____ hp, and shall be multiple-speed direct drive. Blower motor shall be soft mounted to the blower scroll to reduce vibration transmission.

Filters

Furnace shall have reusable-type filters. Filter shall be _____

in (x) _____in. An accessory high efficiency Media Filter is available as an option. _____Media Filter.

Casing

Casing shall be of .030 in. thickness minimum, pre-painted galvanized steel.

Inducer Motor

Inducer motor shall be soft mounted to reduce vibration transmission.

Primary Heat Exchangers

Primary Heat exchangers shall be 3-Pass 20 gauge corrosion resistant aluminized steel of fold-and-crimp sectional design, which operates under negative pressure.

Secondary Heat Exchangers

Secondary Heat exchangers shall be of a flow-through design having a patented interior laminate coating of polypropylene for greater corrosion resistance with fold-and-crimp design, which operates under negative pressure.

Controls

Controls shall include a microprocessor based integrated electronic control board with at least 11 service troubleshooting codes displayed via diagnostic flashing LED light on the control, has ability to store fault codes, when activated a self-test feature checks all major functions of the furnace within one minute, and a replaceable automotive-type circuit protection fuse. Multiple operational settings available including separate blower speeds. Cooling airflow will be selectable between 350 or 400 CFM per ton of air conditioning. Features will also include temporary reduced airflow in the cooling mode for improved dehumidification when a Thermidstat® is selected as the thermostat.

Operating Characteristics

Heating Capacity shall be _____Btuh input; _____Btuh output capacity.

Fuel Gas Efficiency shall be 93% AFUE.

Air delivery shall be _____ cfm minimum at 0.50 in. wg. external static pressure.

Dimensions shall be: depth _____in.; width _____in.; height _____in. (casing only). Height shall be _____in. with A/C coil and _____in. overall with plenum.

Electrical Requirements

Electrical supply shall be 115 volts, 60 Hz, single-phase (nominal). Minimum wire size shall be _____AWG; maximum fuse size or HACR-type, designated circuit breaker shall be _____Amps.

Special Features

Refer to section of the product data sheet identifying accessories and descriptions for specific features and available enhancements.