

Replacement Inducer Housing Kit

Cancels: New IIK-310-45-4
6-02

Installation Instructions Part No. 326627-751 thru 326627-755

Note: Read the entire instruction manual before starting the installation.

SAFETY CONSIDERATIONS

Installing and servicing heating equipment can be hazardous due to gas and electrical components. Only trained personnel should install or service heating equipment.

Untrained personnel can perform basic maintenance functions such as cleaning coils, or cleaning and replacing filters. All other operations should be performed by trained service personnel. When working on heating equipment, observe precautions in the literature, on tags, and on labels attached to the unit. Recognize safety information. This is the safety-alert symbol . When you see this symbol on the unit and in instructions or manuals, be alert to the potential for personal injury.

Understand the signal words DANGER, WARNING, and CAUTION. These words are used with the safety-alert symbol. DANGER identifies the most serious hazards which **will** result in severe personal injury or death. WARNING signifies a hazard which **could** result in personal injury or death. CAUTION is used to identify unsafe practices which **would** result in minor personal injury or product and property damage. NOTE is used to highlight suggestions which **will** result in enhanced installation, reliability, or operation.

Follow all safety codes. Wear safety glasses and work gloves. Have a fire extinguisher available.

 **WARNING:** Improper installation, adjustment, alteration, service, maintenance, or use can cause carbon monoxide poisoning, explosion, fire, electrical shock, or other conditions which could result in personal injury or death. Consult your distributor or branch for information or assistance. The qualified installer or agency must use only factory-authorized kits or accessories when servicing this product. Failure to follow instructions could result in serious injury or property damage.

INTRODUCTION

This instruction covers the inducer housing installation on mid-efficiency hot surface ignitor units. The inducer housing should be replaced when corrosion has created visible surface damage to the box, damage to the pressure switch pressure tap or anytime functionality of the inducer housing has been compromised. There are 4 different primary sizes of inducer housings, each having up to 4 different sizes of flue restriction openings. Total there are 13 different combinations of inducer housings. See Tables 1 and 2 at the end of these instructions for a complete listing of kits and applicable models.

NOTE: It is very important that you verify that the inducer housing you are installing be the same size as you are removing. Always verify the flue restrictor HOLE SIZE before installing an inducer housing. See Table 1 or 2.

DESCRIPTION AND USAGE

The inducer housing replacement kit can be utilized to restore units having inducer housings that require repair. This kit contains the following items: Inducer housing, Inducer housing screws, Inducer motor mounting screws, Vent elbow screws, Inducer motor gasket and Installation Instructions.

INSTALLATION

Note: A releasing agent such as PAM cooking spray or equivalent (must not contain corn or canola oil, aromatic or halogenated hydrocarbons or inadequate seal may occur) and RTV sealant (G.E. 162, G.E. 6702, or Dow-Corning 738) are needed before starting installation. DO NOT substitute any other type of RTV sealant. G.E. 162 (P771-9003) is available through RCD in 3-oz tubes.

Note: It may be helpful to remove the burner box assembly from furnaces with narrow cabinets to facilitate removal of inducer housing. To remove the burner assembly, follow the steps below. If the inducer housing is readily accessible, proceed to Step 2.

Step 1—Remove the Burner Assembly

1. Turn off electric supplies to unit and set thermostat to lowest setting or “OFF”. More than 1 disconnect may be required to disconnect power to unit.
2. Remove exterior door by loosening thumbscrew and pulling door forward.
3. Turn off gas at external supply shut-off and turn electric switch on gas valve to “OFF”.
4. Disconnect wires from gas valve.
5. Disconnect main limit switch wires from main limit switch on cell panel.
6. Disconnect wires from roll-out switches located at the ends of the burner box.
7. Remove wiring harness stand-off from top edge of burner box.
8. Disconnect HSI harness from HSI.
9. Disconnect flame sensor wire from flame sensor.
10. Disconnect gas line at external union or pipe connection.
11. Remove the green/yellow ground wire attached to the manifold mounting tab, re-install screw.
12. Support the burner assembly while removing the 4 screws that attach the burner assembly to the cell panel.

Note: The hot surface ignitor is **extremely** fragile. Failure to support the burner assembly could result in damage to the hot surface ignition.

13. Remove the burner assembly and set aside to prevent damage.

Step 2—Remove the Inducer housing

1. Turn off electric supplies to unit and set thermostat to lowest setting or “OFF”. More than 1 disconnect may be required to disconnect power to unit.
2. Remove exterior door by loosening thumbscrew and pulling door forward.
3. Turn off gas at external supply shut-off and turn electric switch on gas valve to “OFF”. On models with a gas control knob, turn knob to “OFF”.



CAUTION: Vent connector may be hot to the touch or have sharp edges. Gloves should be worn when handling sheet metal parts. Failure to follow this warning could result in personal injury.

4. Disconnect and remove vent connector from vent elbow.

NOTE: Support vent connector with temporary metal strap to prevent damage to vent connector or vent connector elbows.

5. Disconnect draft safeguard switch leads from draft safeguard switch on vent elbow.
 6. Remove vent elbow from inducer housing.
 7. Unplug inducer motor wires from wiring harness.
 8. Disconnect pressure switch tube from inducer housing.
 9. Remove pressure switch bracket from furnace casing. It is not necessary to disconnect pressure switch wires.
 10. Remove screws from top corners of furnace casing (upflow furnaces only).
- Note:** Verify the orientation of the motor wiring harness and inducer cooling shield before removing inducer motor assembly. Inducer motor assembly must be re-installed in same orientation for proper furnace operation.
11. Remove 3 screws securing inducer assembly (motor, wheel, and mount) to inducer housing and remove inducer motor assembly. Note where inducer motor ground lead is connected.



CAUTION: Failure to support the inducer assembly during removal may damage the inducer wheel.

12. Remove screws securing inducer housing to front of cell panel.
13. Use putty knife or automotive-type gasket scraper to carefully pry up on inducer housing assembly where it meets cell panel. Start at the bottom corner and work knife or scraper along inducer housing to break silicone seal. Continue to pry around inducer housing until inducer housing can be removed.

14. Clean any remaining silicone residue from cell panel with a wire brush, scraper or fine steel wool.

Step 3—Installation of Inducer Housing

NOTE: A releasing agent such as PAM cooking spray or equivalent (must not contain corn or canola oil, aromatic or halogenated hydrocarbons or inadequate seal may occur) and RTV sealant (G.E. 162, G.E. 6702, or Dow-Corning 738) are needed before starting installation. DO NOT substitute any other type of RTV sealant. G.E. 162 (P771-9003) is available through RCD in 3-oz tubes.

1. Spray face surface of cell panel with a releasing agent.
2. Apply 3/16-in. to 1/4-in. bead of high temperature silicone around the back outside edge of inducer housing.
On 2 cell models: Measure in 4 inches and apply a vertical bead down the back of the inducer housing (See Fig. 1).

Note: Do not allow RTV to flow into pressure switch port. Pressure switch will not operate with port obstructed.

3. Realign inducer housing assembly against cell panel and install all screws.
4. Verify old inducer motor gasket is removed from inducer assembly and inducer housing.
5. Place new inducer motor gasket provided in kit around flange on inducer housing (See Fig. 2).

NOTE: A new inducer assembly gasket is provided in the inducer housing kit.

6. Align inducer assembly and attach to inducer housing. Verify inducer motor is oriented correctly and ground wire is reinstalled in original location.
7. Spin black plastic cooling fan on inducer motor to be certain there is no interference inside of inducer housing. If interference occurs, wheel must be readjusted.
8. Re-install screws in top corners of furnace casing.
9. Reinstall pressure switch bracket.

Note: Verify pressure switch port on inducer housing plate is not obstructed by inserting a small wire or drill bit into the port. If wire has RTV on it when it is removed, it may be necessary to remove inducer housing, clean pressure switch port area and re-attach inducer housing as explained above.

10. Connect pressure switch tubing to inducer housing fitting.

11. Re-install vent elbow to inducer housing.
12. Re-attach vent connector to vent elbow.
13. Re-connect inducer motor leads to inducer motor and draft safeguard leads to draft safeguard switch.

Step 5-Installation of Burner Assembly

Note: If burner assembly was not removed, proceed to **Step 6**.

Note: The hot surface ignitor is **extremely** fragile. Failure to support the burner assembly could result in damage to the hot surface ignition.

1. Align burner box with mounting holes in cell panel and re-install the 4 mounting screws.
2. Remove the screw from the manifold mounting tab and re-attach the green/yellow ground wire attached to the manifold.

Note: Failure to properly ground burner assembly will result in loss of flame sensing signal.

3. Connect flame sensor wire from flame sensor.
4. Connect HSI harness to HSI.
5. Connect leads to main limit on cell panel.
6. Connect leads to rollout switches on burner box.
7. Attach wiring harness standoff(s) to top edge of burner box.



WARNING: Failure to attach wiring harness standoff(s) may result in damage to the safety circuit wiring. Failure to attach wiring harness standoff could result in equipment damage, fire, personal injury or death.

8. Connect leads to gas valve. Refer to wiring diagram for correct orientation.
9. Connect gas line at external union or pipe connection.
10. Turn on gas at gas supply shut-off and gas control (knob or switch).
11. Leak test gas connections with soap and water solution or electronic leak detection equipment suitable for use with natural and propane gases.



WARNING: Never purge a line into a combustion chamber. Never use matches, candles, flame, or other sources of ignition for the purpose of checking leakage. Use a soap-and-water solution to check for leakage. Failure to follow this warning can cause fire, explosion, personal injury, or death.

14. Turn on line voltage electrical supply.

NOTE: Blower will run for 90 sec if thermostat is set to call for heat when 120-v power is restored. A status code 12 will flash after 90 sec. To clear the status code, turn off power, turn thermostat “OFF” or down below room setting. Turn power back on. Set thermostat to desired temperature.

Step 6—System Check-Out

1. Set thermostat to “OFF”. Initiate component test through circuit board by referring to “**Component Test**” on status code label on blower access door for complete test sequence information.

2. If any status codes are flashed, refer to status code label on unit blower door.

3. Set thermostat to call for heat.

4. Allow unit to initiate a complete call for heat cycle.

5. Check for air leakage around inducer housing. A whistling noise may indicate air leak in inducer housing seal.

NOTE: If there is a severe air leak in the inducer housing seal, pressure switch may not close or will re-open, resulting in no ignition or erratic burner operation.

NOTE: Corrosion at the inducer housing may have been caused by one or more of the following conditions. As part of the system check-out, verify that the following conditions are not affecting the operation of the furnace:

- **Short Cycling-Defective thermostat:** Incorrect thermostat anticipator setting, dirty filter or over-sized furnace.
- **Under firing/low BTU input:** Set manifold pressure and verify firing rate as shown on rating plate by clocking the gas meter.
- **Low temperature rise:** Set unit for correct temperature rise range as shown on unit rating plate.
- **Contaminated combustion air:** Remove contaminants or provide ample fresh air for combustion.
- **Excessive amounts of outside ventilation air:** Return air temperature cannot be below 60 degrees F for extended periods of time.
- **Incorrect venting:** Verify proper venting per local code. Type B vent connector is required for 2 stage units and may be required for other applications.

For additional information, and a complete sequence of furnace operation, refer to furnace Installation, Start-Up and Operating Instructions.

6. After System Check-out is complete, set thermostat below room temperature.

7. Verify that burner shuts down and blower completes selected off delay furnace time.

8. Verify furnace operates properly and set thermostat to desired room temperature.

9. Re-install outer door.

Apply 3/16" to 1/4" silicone bead across inducer housing as shown on 2 cell models only

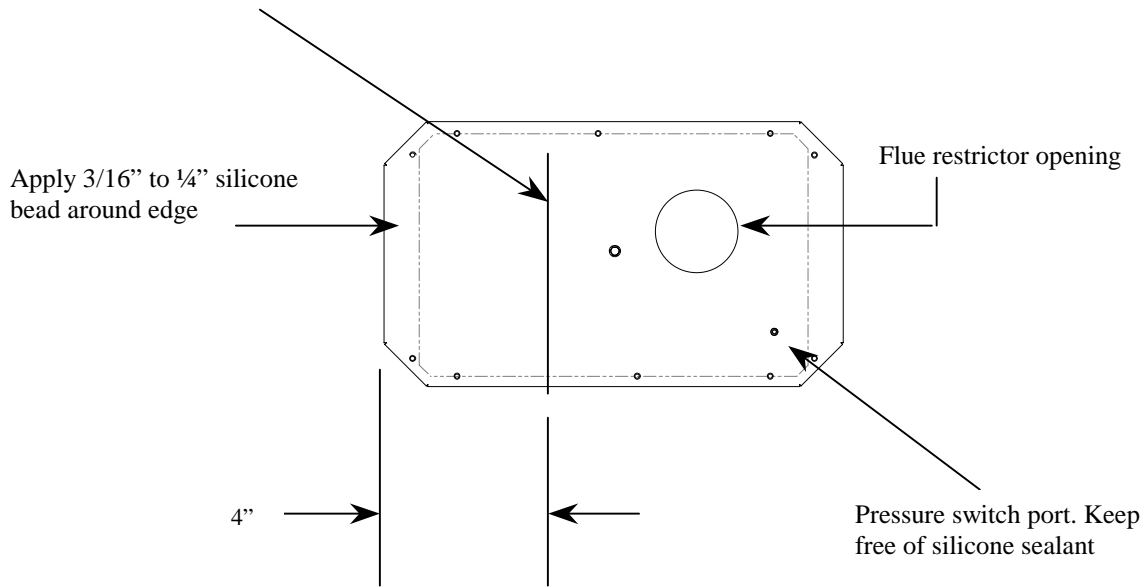

Fig. 1-Inducer housing

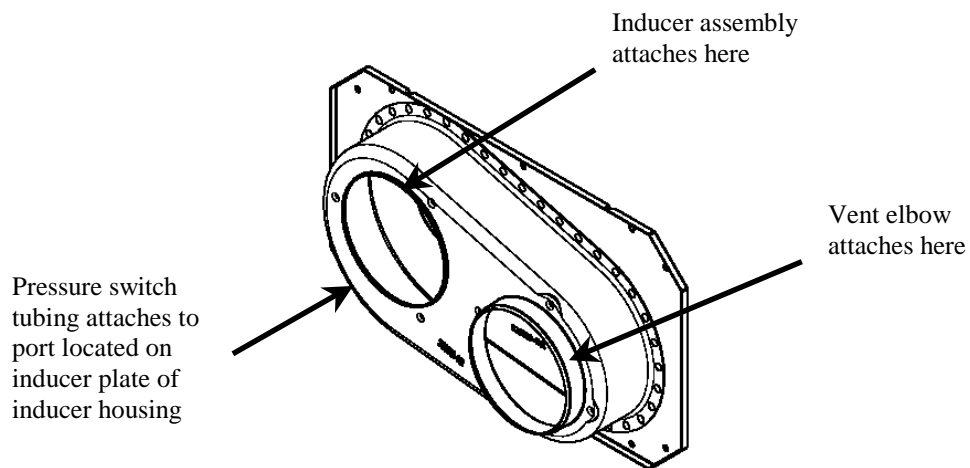

Fig. 2 – Front view of Inducer Housing

Table 1-Inducer Housing/Inducer Housing Kit Usage

*Single and Two-stage Furnaces**

Furnace Size

Inducer housing kit	024045	024070	036045	036070	036110	042090	048070
	045-08	070-08	045-12	070-12	110-12	090-14	070-16
326627-751	X						
326627-752						X	
326627-753					X		
326627-754							
326627-755							
326627-756			X				
326627-757		X					
326627-758				X			
326627-759							X
326627-760							
326627-761							
326627-762							
326627-763							
326627-764							

Furnace Size

Inducer housing kit	048090	048110	048135	060090	060155	066110	066135
	090-16	110-16	135-16	090-20	155-20	110-22	135-22
326627-751							
326627-752							
326627-753							
326627-754			X				
326627-755					X		
326627-756							
326627-757							
326627-758							
326627-759							
326627-760	X						
326627-761				X			
326627-762		X				X	
326627-763							
326627-764							X

**Two-Stage Furnaces have PSC Blower Motors.*

Table 2-Inducer Housing/Inducer Housing Kit Usage

*Variable-Speed Furnaces**

Furnace Size

Inducer housing kit	036070	048090	066110	066135	060155
	070-12	090-16	110-22	135-22	155-20
326627-751					
326627-752		X			
326627-753					
326627-754					
326627-755					X
326627-756					
326627-757					
326627-758	X				
326627-759					
326627-760					
326627-761					
326627-762			X		
326627-763					
326627-764				X	

**Variable Speed Furnaces have ECM Blower Motors.*

