

Torsion-Flex Motor mount for PSC motors and Rigid-Mount for ECM motors Replacement Kit

Cancels: New

IJK-310A-45-11

6/02

Installation Instructions

Part No. 327752-401, Part No. 327753-401

Part No. 327754-401

NOTE: Read the entire instruction manual before starting the installation.

SAFETY CONSIDERATIONS

Installing and servicing heating equipment can be hazardous due to gas and electrical components. Only trained personnel should install or service heating equipment.

Untrained personnel can perform basic maintenance functions such as cleaning coils, or cleaning and replacing filters. All other operations should be performed by trained service personnel. When working on heating equipment, observe precautions in the literature, on tags, and on labels attached to the unit. Recognize safety information. This is the safety-alert symbol . When you see this symbol on the unit and in instructions or manuals, be alert to the potential for personal injury.

Understand the signal words DANGER, WARNING, and CAUTION. These words are used with the safety-alert symbol, . DANGER identifies the most serious hazards which **will** result in severe personal injury or death. WARNING signifies a hazard which **could** result in personal injury or death. CAUTION is used to identify unsafe practices which **would** result in minor personal injury or product and property damage. NOTE is used to highlight suggestions which **will** result in enhanced installation, reliability, or operation.

Follow all safety codes. Wear safety glasses and work gloves. Have a fire extinguisher available.



WARNING: Improper installation, adjustment, alteration, service, maintenance, or use can cause carbon monoxide poisoning, explosion, fire, electrical shock, or other conditions which could result in personal injury or death. Consult your distributor or branch for information or assistance. The qualified installer or agency must use only factory-authorized kits or accessories when servicing this product. Failure to follow instructions could result in serious injury or property damage.

INTRODUCTION

This instruction covers the installation of replacement torsion-flex motor mount or rigid motor mount on non-condensing, 33.3-inch high, mid-efficiency hot surface igniter furnaces.

DESCRIPTION AND USAGE

These kits can be utilized to replace a blower motor with an approved service replacement motor instead of using the original factory motor with the mounting arms directly attached to the motor. This kit contains the following items (See Table 1)

Table 1-Kit Contents

Kit No. 327752-401	Qty.
3 arm Torsion Flex Mount (PSC)	1
Self-locking ¼-20 hex nut	1
¼-20 x 1 ½" long hex bolt	1
Rubber grommets w/steel inserts	3
Instruction sheet	1

Kit No. 327753-401	Qty.
4 arm Torsion Flex Mount (PSC)	1
Self-locking ¼-20 hex nut	1
¼-20 x 1 ½" long hex bolt	1
Rubber grommets w/steel inserts	4
Instruction sheet	1

Kit No. 327754-401	Qty.
4 arm Rigid Mount (ECM)	1
Self-locking ¼-20 hex nut	1
¼-20 x 1 ½" long hex bolt	1
Rubber grommets	4
Instruction sheet	1

A replacement motor, capacitor or ECM module is **NOT** included in this kit and must be ordered separately if needed.

SFM2453

INSTALLATION

Step 1—Remove the Existing Blower Assembly

1. Turn off electric supplies to unit and thermostat. More than 1 disconnect may be required to disconnect power to unit.
2. Remove exterior door by loosening knurled knob on door and pulling forward.
3. Turn off gas at external supply shutoff and turn electric switch on gas control "OFF"

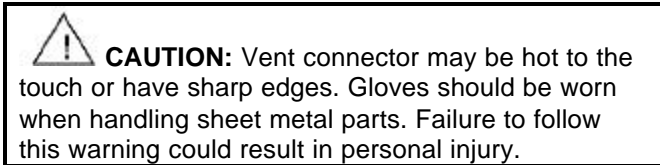

4. On downflow or horizontal positions where the vent connector passes in front of the blower access panel, disconnect and remove vent connector from vent elbow.

NOTE: Support vent connector with temporary metal strap to prevent damage to vent connector or vent connector elbows.

5. Remove the 2 screws that secure the blower access door and set door aside.
6. Remove the screw that secures the blower door switch to the front edge of the heat exchanger cell panel. Do not disconnect blower door switch wires.
7. Remove the wiring harness from the recess in the blower shelf.
8. Remove the blower leads that connect the motor to the furnace control board and capacitor.

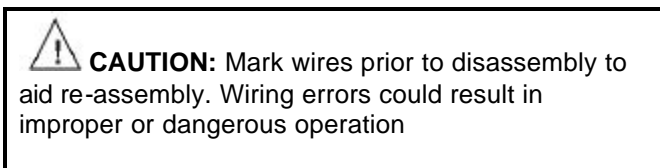

Note: Pull motor lead terminals straight out of control connectors instead of pulling on wires to prevent damage to the relay terminal on top of the control relays.

9. On some Variable Speed (ECM) furnace models, disconnect the wires from the motor.
10. Remove the 2 screws that secure the control assembly to the blower shelf inside the blower compartment. Do not discard.

11. Move the control aside. Secure control assembly aside with a scrap length of wire or tape.
12. Using a 5/16-nut driver remove the blower housing mounting screws that secure the blower assembly to the blower shelf.
13. Slide the blower assembly forward, out of the blower compartment.

Step 2—Remove Blower Motor

1. Clean blower wheel with a small paintbrush or flux brush. Be careful not to dislodge balance clips attached to the blower wheel blades.
2. Loosen the setscrew that attaches the blower wheel to the flat on the motor shaft.
3. Lay the blower assembly on its side and remove the 3 or 4 screws that secure the motor mounting arms to the blower housing.
4. Remove the green ground lead from the side of the blower housing. Note the location for re-assembly
5. Slide the motor out of the blower wheel hub.

Note: If the motor will not slide out of the wheel, perform the following steps:

6. Set the blower assembly, motor side down on a crate or wooden box with a generous amount of padding inside.
7. Apply a small amount of lubricant between the shaft of the motor and the hub of the blower wheel.
8. Tap the shaft of the motor using a block of wood, wooden dowel pin or a 3/4" brass drift pin. **DO NOT HAMMER DIRECTLY ON THE SHAFT OF THE MOTOR.** The motor shaft may "mushroom" and prevent the motor from being removed from the wheel.

You may also use a commercially available tool that clamps on the blower wheel hub and pushes the motor shaft out of the wheel. When the motor drops into the box or crate, remove it from the box and set it aside.

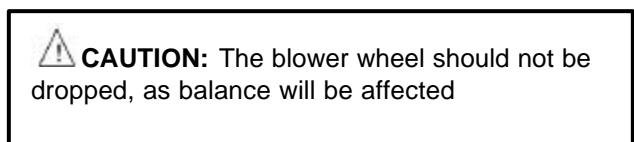

Step 3-Assemble the replacement motor mount and motor

1. Verify that the grommets and inserts (if used) are inserted in the mounting legs correctly per Fig. 1.
2. Place the motor mount around the mid-section of the motor. Position the motor around the mid-section of the motor as shown in Table 1.

Note: Failure to correctly position the motor may result in unwanted noise or vibration in the blower assembly.

3. Slightly tighten the hex nut and bolt to allow the motor mount to slide up and down the shell of the motor.

4. Rotate the motor in the band for correct alignment-

For 3-arm PSC Motors: With one mounting leg positioned at 12 o'clock, rotate the motor so that the GE logo (on the undrilled oiler boss) on the end of the motor is positioned slightly to the left (5 degrees) of the mounting leg (See Fig. 2).

For 4-arm PSC Motors: Position GE logo (on the undrilled oiler boss) on the end of the motor centered between two of the mounting arms (See Fig. 2).

For ECM Motors: Position control and power connectors centered between two of the mounting arms (See Fig. 2).

Recheck alignment from **Step 2** and torque mounting band bolt and nut to a minimum of 80 in.-lbs.

Step 4—Assemble the Blower

1. Insert blower motor shaft into hub of blower wheel.
2. Check to see the blower wheel is not jammed against the blower housing before installing motor mounting screws.
3. Align the motor mounting arms as shown in Fig. 1. See Table 1 for the correct Dimension "A", as shown in Fig. 1

PSC motors are properly positioned if the undrilled oiler boss is pointing toward the rear of the blower housing. See Fig. 2

ECM motors are properly positioned if the connectors on the motor modules are pointing away from the blower discharge air opening. See Fig 2

Note: See Fig 3 and Fig 4 for additional blower assembly information.

5. Install blower motor mounting screws in previously used holes in blower housing. Torque to 30 to 50 in.-lbs. Do not over-tighten.

Note: Over tightening screws on mounting legs may result in stripped out screw holes. If a screw hole is stripped, remove all screws and rotate the mounting band to the next set of screw holes provided in the blower assembly.

6. Attach the green ground wire from the motor to the sheet metal of the blower housing on furnaces with PSC motors. ECM motors are grounded through the 5-pin connector harness in the same location.



WARNING: The furnace must be grounded to minimize personal injury if an electrical short should occur. Failure to follow this warning could result in personal injury of death.

7. Center the blower wheel in the opening of the blower housing. Align the set-screw on the flat portion of the blower shaft. Torque set screw to a minimum of 140 in.-lbs to a maximum of 160 in.-lbs

Step 5-Install Blower Assembly in Furnace

1. Insert the flanges of the blower housing into the rail of the furnace blower deck
2. Slide the blower assembly into the furnace until it is fully seated in the blower compartment.
3. Install the 5/16" screws to blower deck in the furnace through the opening in the flange on the blower housing.
4. Tighten the screws with a 5/16" nut driver.
5. Install the control assembly to the front of the blower shelf of the furnace.
- 6a. Connect the electrical leads to the terminals on the control assembly. If wires were not marked during disassembly, refer to the wiring label on the blower access door.
- 6b. On ECM models, plug 5-pin and 16-pin connectors into the motor module. Both connectors are indexed for correct orientation.
7. Install the wiring harness in the recess of the front edge of the heat exchanger cell panel.

8. Secure the wiring harness by installing the blower door switch bracket to the front edge of the heat exchanger cell panel. Use caution when installing the switch to prevent wires from being pinched.

9. Spin blower wheel by hand to verify that wheel does not rub against housing.

Step 6—System Check-Out

1. Set thermostat to “OFF”. Manually close blower door switch. Initiate component test through circuit board by referring to “**Component Test**” on status code label on blower access door for complete test sequence information.

2. If any status codes are flashed, refer to status code label on unit blower door.

3. Release the blower door switch

4. Install blower access panel on furnace and secure with the 2 existing screws.

5. Turn thermostat fan switch to “ON”, to initiate a call for continuous fan operation.

6. Verify that the blower wheel does not rub against the housing.

7. On Downflow or Horizontal models, install the vent connector if the connector was removed. Verify that no other connectors or joints were damaged during disassembly.

8. Turn gas ON at external shut off and at electric switch on gas valve.

9. Set thermostat to call for heat.

10. Allow unit to initiate a complete call for heat cycle.

NOTE: Blower motor failure may have been caused by one or more of the following conditions. As part of the system check-out, verify that the following conditions are not affecting the operation of the furnace:

- **High external static pressure:**
Dirty filter or high pressure drop filter.
Undersized filter grills. Restricted or undersized duct systems. Dirty evaporator coil.
- **Noise:** High air flow due to high external static pressure. Incorrect speed tap selected for heating temperature rise or cooling airflow. Improper motor positioning in mounting band.
- **Vibration:** Unit not set flat or level. Blower wheel bent or out of balance. Flexible duct connectors not used with sheet metal ducts. Improper motor positioning in mounting band.

For additional information, and a complete sequence of furnace operation, refer to furnace Installation, Start-Up and Operating Instructions.

10. After System Check-out is complete, set thermostat below room temperature.

11. Verify that burner shuts down and blower completes selected off delay furnace time delay. Verify furnace operates properly and set thermostat to desired room temperature.

12. Re-install outer door.

TABLE 1

FURNACE				PSC MOTOR "A" Dim				Variable-Speed (ECM) Motor	
Model Size	Model Size	Casing Width	Wheel Dia x Width	HP	3-Speed	4-Speed	5-Speed	HP	"A" dimension
024045	045-08	14	10x6	1/5	0.94	1.18			
036045	045-12	14	10x6	1/3	0.68	0.68	1.88		
024070	070-08	14	10x6	1/5	0.94	1.18			
036070	070-12	14	10x6	1/3	0.68	0.68	1.88	1/2	1.10
048070	070-16	17	11x8	1/2	1.00	1.00	1.65		
042090	090-14	17	10x8	1/3	0.68	0.68			
048090	090-16	17	10x8					1/2	1.10
048090	090-16	21	10x10	1/2	1.00	1.00	1.65		
060090	090-20	21	11x11	3/4	1.00	1.00	1.75		
036110	110-12	17	10x8	1/3	0.68	0.68			
048110	110-16	21	10x10	1/2	1.00	1.00	1.65		
066110	110-66	21	11x11	3/4	1.00	1.00	1.75	1	1.56
048135	135-16	21	10x10	1/2	1.00	1.00			
060135	135-20	24	11x11	3/4	1.00	1.00		1	1.56
060155	155-20	24	11x11	3/4	1.00	1.00		1	1.56

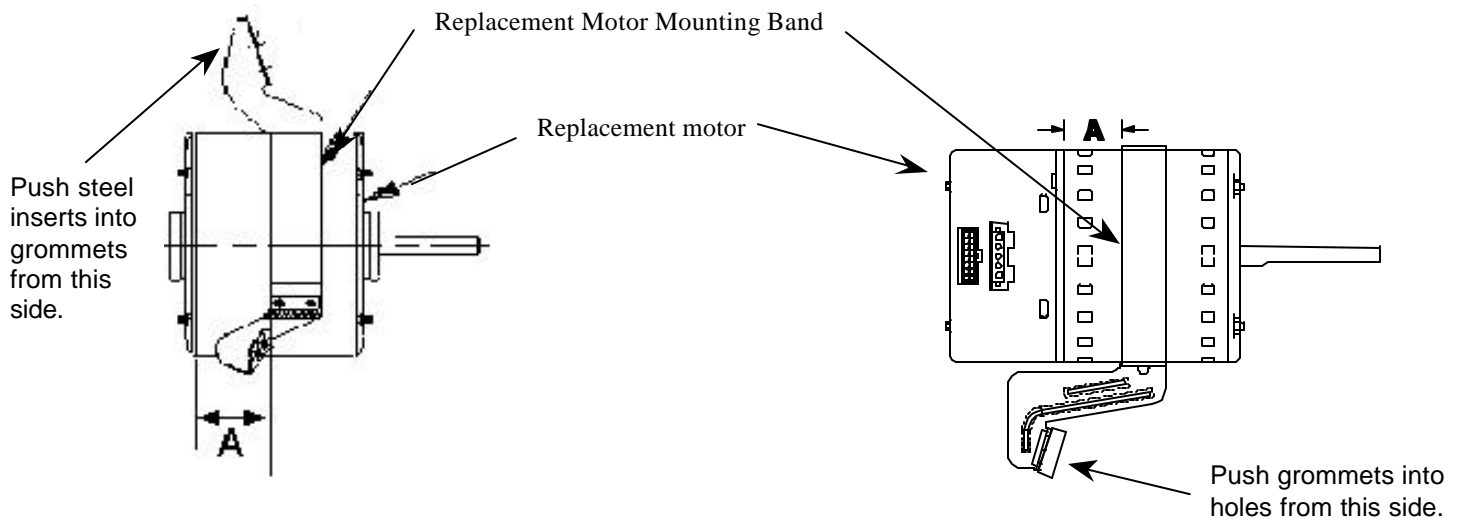

Fig. 1-Dimension "A", Motor Mounting Band Location

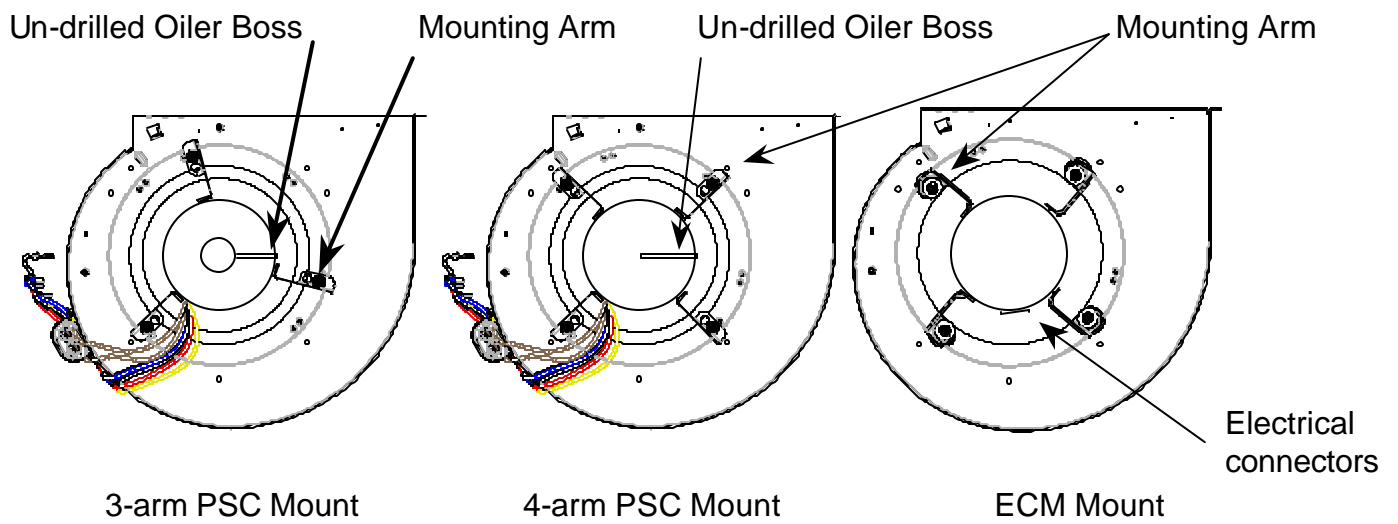

Fig. 2-Orientation Of Motor

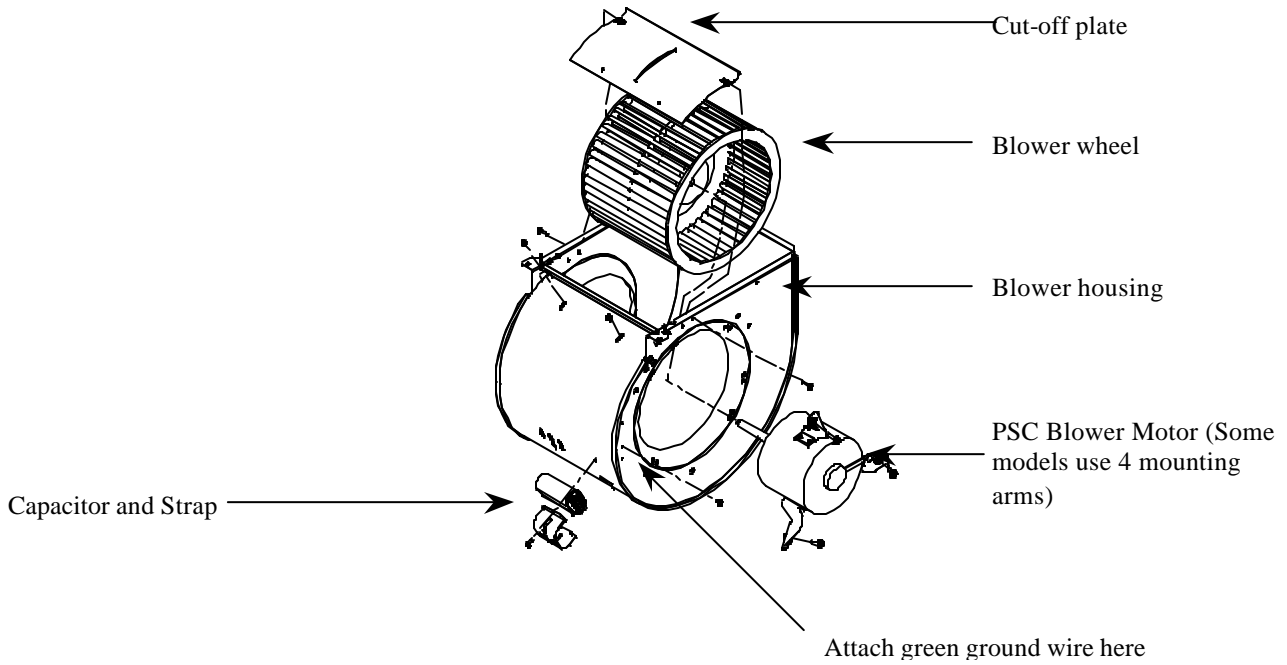

Fig. 3-Expanded View of PSC Blower Assembly

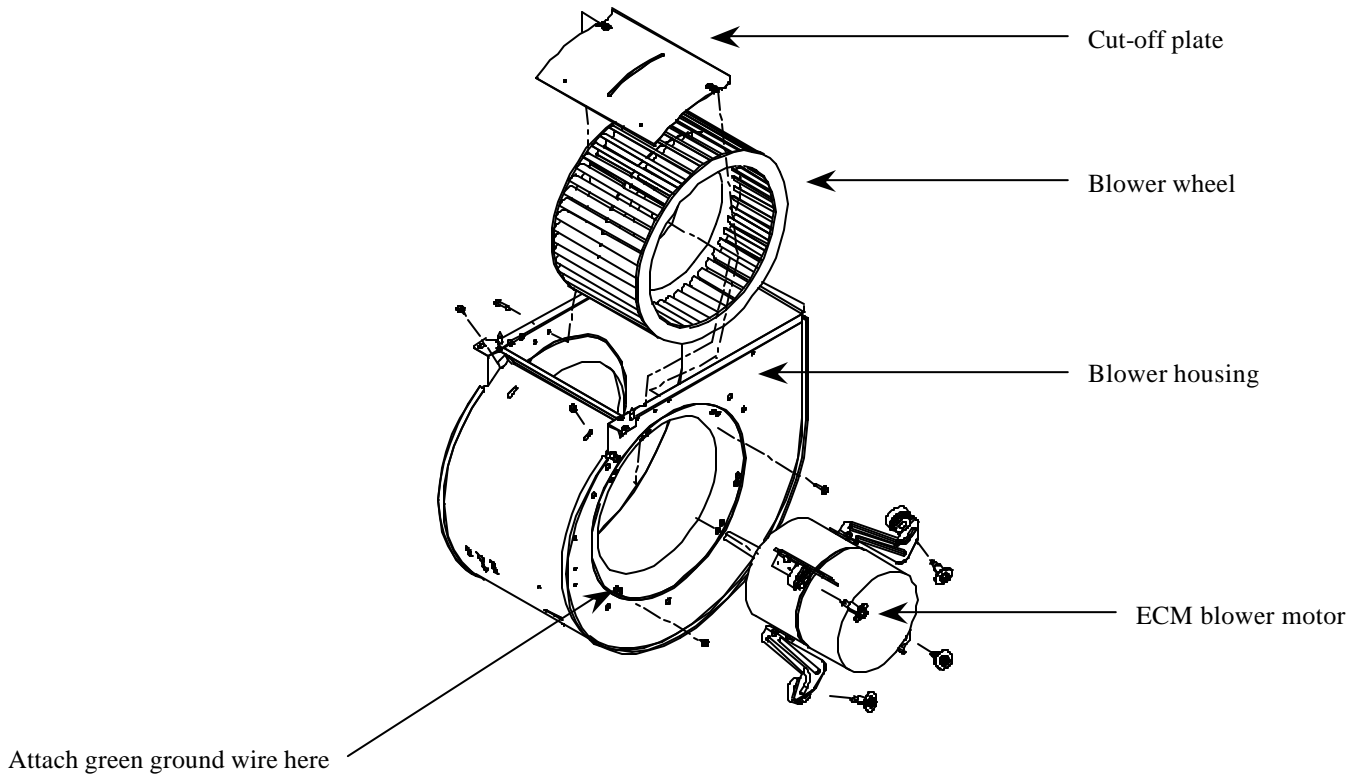

Fig. 4-Expanded View of ECM Blower Assembly

Manufacturer reserves the right to discontinue, or change at any time, specifications or designs without notice and without incurring obligations.

PC 101

Catalog No. 535-80088

Printed in U.S.A

Form 58ST-10SI

Pg. 8

6/02

Replaces: New