



Installation, Start-Up, and Operating Instructions

Sizes 045-155, Series 131

NOTE: Read the entire instruction manual before starting the installation.

This symbol → indicates a change since the last issue.

Index	Page
SAFETY CONSIDERATIONS	1
Clearances From Combustible Materials	1
Dimensional Drawing	2
ELECTROSTATIC DISCHARGE (ESD) PRECAUTIONS	
PROCEDURE	2-3
INTRODUCTION	3
LOCATION	3
General	3
Location Relative to Cooling Equipment	3
Hazardous Locations	3
AIR FOR COMBUSTION AND VENTILATION	3-5
Unconfined Space	4
Confined Space	4-5
FILTER ARRANGEMENT	5-6
LEVELING LEGS (IF REQUIRED)	5-6
GAS PIPING	6-7
ELECTRICAL CONNECTIONS	7
115-v Wiring	7
24-v Wiring	7
Accessories	7
VENTING	7
START-UP, ADJUSTMENT, AND SAFETY CHECK	7-14
General	7-8
Sequence Of Operation	8-11
Heating Mode	9
Cooling Mode	9-11
Continuous Blower Mode	11
Heat Pump Mode	11
Start-Up Procedures	11
Adjustments	11-14
Set Gas Input Rate	11-12
Set Temperature Rise	13-14
Set Thermostat Heat Anticipator	14
Check Safety Controls	14
Checklist	14

SAFETY CONSIDERATIONS

Installing and servicing heating equipment can be hazardous due to gas and electrical components. Only trained and qualified personnel should install, repair, or service heating equipment.

Untrained personnel can perform basic maintenance functions such as cleaning and replacing air filters. All other operations must be performed by trained service personnel. When working on heating equipment, observe precautions in the literature, on tags, and on labels attached to or shipped with the unit and other safety precautions that may apply.

Follow all safety codes. In the United States, follow all safety codes including the National Fuel Gas Code (NFGC) NFPA No. 54-1992/ANSI Z223.1-1992. In Canada, refer to the current



edition of the National Standard of Canada CAN/CGA-B149.1- and .2-M91 Natural Gas and Propane Installation Codes (NSC-NGPIC). Wear safety glasses and work gloves. Have fire extinguisher available during start-up and adjustment procedures and service calls.

Recognize safety information. This is the safety-alert symbol . When you see this symbol on the furnace and in instructions or manuals, be alert to the potential for personal injury.

Understand the signal words DANGER, WARNING, and CAUTION. These words are used with the safety-alert symbol. DANGER identifies the most serious hazards which **will** result in severe personal injury or death. WARNING signifies a hazard which **could** result in personal injury or death. CAUTION is used to identify unsafe practices which **would** result in minor personal injury or product and property damage. NOTE is used to highlight suggestions which **will** result in enhanced installation, reliability, or operation.

These instructions cover minimum requirements and conform to existing national standards and safety codes. In some instances, these instructions exceed certain local codes and ordinances, especially those that may not have kept up with changing residential construction practices. We require these instructions as a minimum for a safe installation.

Table 1—Minimum Clearances From Combustible Materials (In.)

UNIT SIZE		045 AND 070	091-155
Sides	Single-Wall Vent	1	0
	Type B-1 Double-Wall Vent	0	0
Back		0	0
Plenum Top		1	1
Vent	Single-Wall Vent	6	6
	Type B-1 Double-Wall Vent	1	1
Front	Single-Wall Vent	6	6
	Type B-1 Double-Wall Vent	3	3
	Service	30	30

NOTES:

1. Provide 30-in. front clearance for servicing. An open door in front of the unit can meet this requirement.
2. A minimum clearance of 3 in. must be provided in front of the unit for combustion air and proper operation.

Manufacturer reserves the right to discontinue, or change at any time, specifications or designs without notice and without incurring obligations.

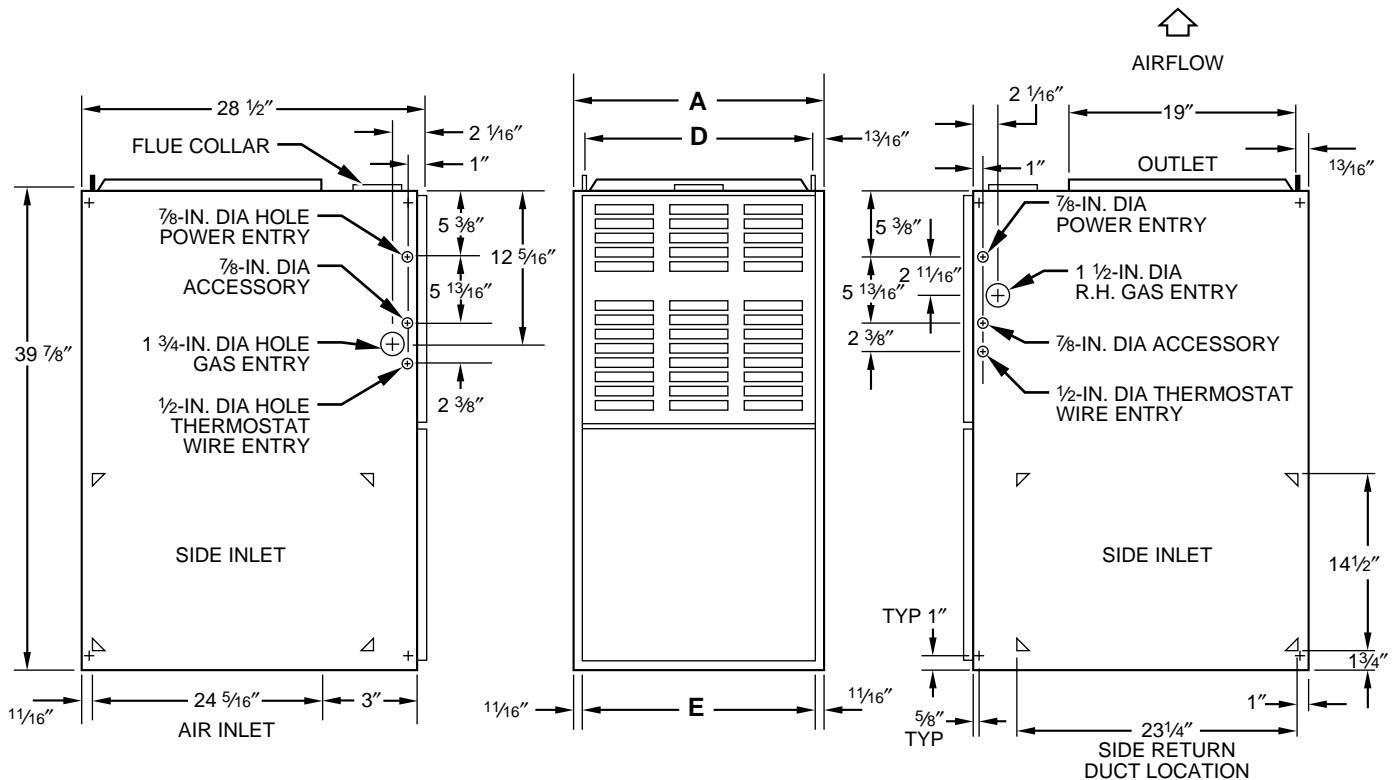

NOTE: 2 additional 7/8 In. Dia knockouts are located in the top plate.

NOTES: Minimum return-air opening at furnace:

1. For 800 CFM—16-In. round or 14 1/2 x 12-In. rectangle.
2. For 1200 CFM—20-In. round or 14 1/2 x 19 1/2-In. rectangle.
3. For 1600 CFM—22-In. round or 14 1/2 x 23 1/4-In. rectangle.
4. For airflow requirements above 1800 CFM, use both side inlets, a combination of 1 side inlet and the bottom, or the bottom only.

A88367

Fig. 1—Dimensional Drawing

Table 2—Dimensions (In.)

UNIT SIZE	A	D	E	VENT CONN	SHIP. WT (LB)
045-08	14-3/16	12-9/16	12-11/16	4	122
045-12	14-3/16	12-9/16	12-11/16	4	124
070-08	14-3/16	12-9/16	12-11/16	4	132
070-12	14-3/16	12-9/16	12-11/16	4	134
091-14	17-1/2	15-7/8	16	4	150
091-16	21	19-3/8	19-1/2	4	154
111-12	17-1/2	15-7/8	16	4	160
111-16	21	19-3/8	19-1/2	4	166
111-20	24-1/2	22-7/8	23	4	184
136-16	21	19-3/8	19-1/2	5	178
136-20	24-1/2	22-7/8	23	5	194
155-20	24-1/2	22-7/8	23	5	204

ELECTROSTATIC DISCHARGE (ESD) PRECAUTIONS PROCEDURE

⚠ CAUTION

Electrostatic discharge can affect electronic components. Take precautions during furnace installation and servicing to protect the furnace electronic control. Precautions will prevent electrostatic discharges from personnel and hand tools which are held during the procedure. These precautions will help to avoid exposing the control to electrostatic discharge by putting the furnace, the control, and the person at the same electrostatic potential.

1. Disconnect all power to the furnace. DO NOT TOUCH THE

CONTROL OR ANY WIRE CONNECTED TO THE CONTROL PRIOR TO DISCHARGING YOUR BODY'S ELECTROSTATIC CHARGE TO GROUND.

2. Firmly touch a clean, unpainted, metal surface of the furnace chassis which is close to the control. Tools held in a person's hand during grounding will be satisfactorily discharged.
3. After touching the chassis you may proceed to service the control or connecting wires as long as you do nothing that recharges your body with static electricity (for example; DO NOT move or shuffle your feet, DO NOT touch ungrounded objects, etc.).
4. If you touch ungrounded objects (recharge your body with static electricity), firmly touch furnace again before touching control or wires.

5. Use this procedure for installed and uninstalled (ungrounded) furnaces.
6. Before removing a new control from its container, discharge your body's electrostatic charge to ground to protect the control from damage. If the control is to be installed in a furnace, follow items 1 through 5 before bringing the control or yourself into contact with the furnace. Put all used AND new controls into containers before touching ungrounded objects.
7. An ESD service kit (available from commercial sources) may also be used to prevent ESD damage.

INTRODUCTION

The Model 58WAV, Series 131 Furnace is available in sizes 45,000 through 155,000 Btuh input capacities.

The design of the upflow gas-fired furnace is A.G.A./C.G.A. certified for natural and propane gas and for installation on combustible flooring, in alcoves, attics, basements, closets, or utility rooms. The design of this furnace line is **not** A.G.A./C.G.A. certified for installation in mobile homes, recreation vehicles, or outdoors.

Before installing the furnace, refer to the current edition of the NFGC. Canadian installations must be installed in accordance with NSCNPIC and all authorities having jurisdiction. For further information, the NFGC is available from National Fire Protection Association Inc., Batterymarch Park, Quincy, MA 02269; American Gas Association, 1515 Wilson Boulevard, Arlington, VA 22209; or from Literature Distribution.

Installation must conform to the regulations of the serving gas supplier and the local building, heating, and plumbing codes in effect in the area in which the installation is made, or in the absence of local codes with the requirements of the NFGC.

⚠ CAUTION

Application of this furnace should be indoors with special attention given to vent sizing and material, gas input rate, air temperature rise, and unit sizing. Improper installation or misapplication of the furnace can require excessive servicing or cause premature component failure.

This furnace is designed for a minimum continuous return-air temperature of 60°F db or an intermittent operation down to 55°F db such as when used with a night setback thermostat. Return-air temperature must not exceed a maximum of 85°F db.

⚠ WARNING

Improper installation, adjustment, alteration, service, maintenance, or use can cause carbon monoxide poisoning, explosion, fire, electrical shock, or other conditions which may cause personal injury or property damage. Consult a qualified installer, service agency, local gas supplier, or your distributor or branch for information or assistance. The qualified installer or agency must use only factory-authorized and listed kits or accessories when modifying this product. Failure to follow this warning can cause electrical shock, fire, personal injury, or death.

For accessory installation details, refer to the applicable instruction literature.

NOTE: Remove all shipping brackets and materials before operating the furnace.

Step 1—Location

GENERAL

⚠ CAUTION

Do not install furnace in a corrosive or contaminated atmosphere. Make sure all combustion and circulating air requirements are met, in addition to all local codes and ordinances.

⚠ CAUTION

Do not use this furnace during construction when adhesives, sealers, and/or new carpets are being installed. If the furnace is required during construction, use clean outside air for combustion and ventilation. Compounds of chlorine and fluorine when burned with combustion air form acids which cause corrosion of the heat exchangers and metal vent system. Some of these compounds are found in paneling and dry wall adhesives, paints, thinners, masonry cleaning materials, and many other solvents commonly used in the construction process.

This furnace must be installed so the electrical components are protected from water. This furnace shall not be installed directly on carpeting, tile, or any combustible material other than wood flooring.

Locate furnace as close to the chimney/vent and as near the center of the air distribution system as possible. The furnace should be installed as level as possible.

When a furnace is installed so that the supply ducts carry air to areas outside the space containing the furnace, the return air must also be handled by a duct(s) sealed to the furnace casing and terminating outside the space containing the furnace.

Provide ample space for servicing and cleaning. Always comply with the minimum fire protection clearances shown on the unit rating plate.

LOCATION RELATIVE TO COOLING EQUIPMENT — The cooling coil must be installed parallel with or on the downstream side of the unit to avoid condensation in the heat exchangers. When installed parallel with a furnace, dampers or other means used to control the flow of air must prevent chilled air from entering the unit. If the dampers are manually operated, they must be equipped with means to prevent operation of either unit unless the damper is in the full-heat or full-cool position.

HAZARDOUS LOCATIONS — When the furnace is installed in a residential garage, it must be installed so that the burners and ignition source are located at least 18 in. above the floor. The furnace should be protected from physical damage by vehicles. When a furnace is installed in public garages, airplane hangars, or other buildings having hazardous atmospheres, the unit must be installed in accordance with the recommended good practice requirements of the National Fire Protection Association, Inc.

Step 2—Air For Combustion and Ventilation

Provisions for adequate combustion and ventilation air must be provided in accordance with Section 5.3 of the NFGC, Air for Combustion and Ventilation, or applicable provisions of the local building codes.

Canadian installations must be installed in accordance with NSCNPIC and all authorities having jurisdiction.

⚠ CAUTION

Air for combustion must not be contaminated by halogen compounds, which include fluoride, chloride, bromide, and iodide. These elements are found in aerosol sprays, detergents, bleaches, cleaning solvents, salts, air fresheners, and other household products.

All fuel-burning equipment must be supplied with air for combustion of the fuel. Sufficient air **MUST** be provided to ensure there will not be a negative pressure in the equipment room or space. In addition, a positive seal must be made between the furnace cabinet and the return-air duct to prevent pulling air from the burner area and draft safeguard opening.

⚠ CAUTION

The operation of exhaust fans, kitchen ventilation fans, clothes dryers, or fireplaces could create a **NEGATIVE PRESSURE CONDITION** at the furnace. Make-up air **MUST BE PROVIDED** for the ventilation devices, in addition to that required by the furnace.

The requirements for combustion and ventilation air depend upon whether the furnace is located in an unconfined or confined space. **UNCONFINED SPACE** — An unconfined space must have at least 50 cubic ft for each 1000 Btuh of input for all the appliances (such as furnaces, clothes dryer, water heaters, etc.) in the space. For Example:

58WAV FURNACE INPUT BTUH	MINIMUM SQ FT WITH 7-1/2 FT CEILING
44,000	293
66,000	440
88,000	587
110,000	733
132,000	880
154,000	1026

If the unconfined space is constructed unusually tight, air for combustion and ventilation **MUST** come from either the outdoors or spaces freely communicating with the outdoors. Combustion and ventilation openings must be sized the same as for a confined space. A minimum opening with a total of at least 1 sq in. per 5000 Btuh of total input rating for all equipment must be provided. Return air must not be taken from the room unless an equal or greater amount of air is supplied to the room.

CONFINED SPACE — A confined space has volume less than 50 cu ft per 1000 Btuh of the total input rating for all appliances installed in that space. A confined space **MUST** have 2 permanent openings, 1 within 12 in. of the ceiling and the other within 12 in. of the floor. (See Fig. 2.)

NOTE: In determining the free area of an opening, the blocking effect of the louvers, grilles, and screens must be considered. If the free area of a louver or grille design is unknown, it may be assumed that wood louvers have a 20 percent free area, and metal louvers or grilles have a 60 percent free area. Screens, when used, must not be smaller than 1/4-in. mesh. Louvers and grilles must be constructed so they cannot be closed.

The size of the openings depends upon whether the air comes from inside or outside of the structure.

1. All air from inside the structure:
 - a. Each opening **MUST** have at least 1 sq in. of free area per 1000 Btuh of the total input for all equipment within the confined space, but not less than 100 sq in. per opening. (See Fig. 2.)

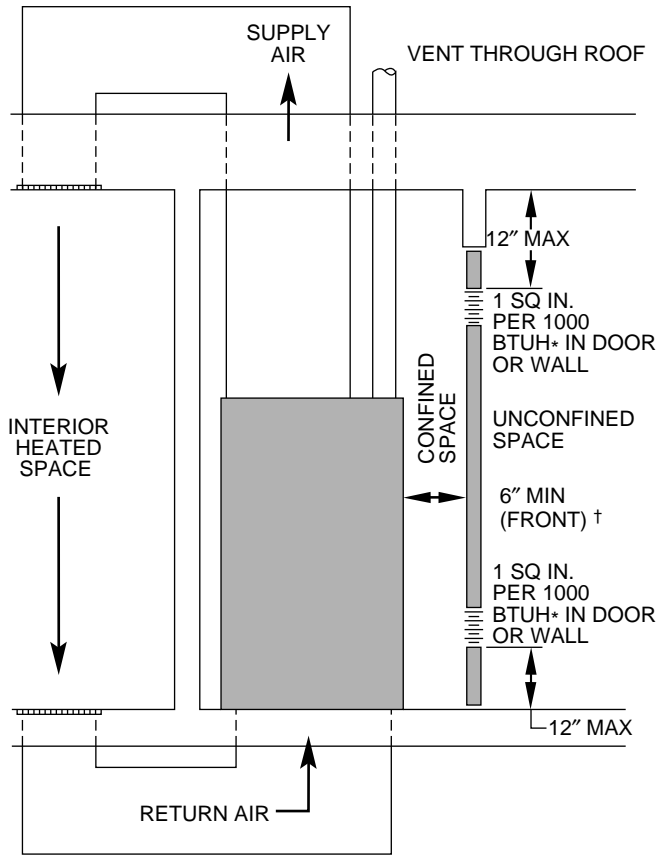

* Minimum opening size is 100 square in. with minimum dimensions of 3-in.
 † Minimum of 3-in. when type-B1 vent is used.

A89012

Fig. 2—Air For Combustion and Ventilation (Inside Air)

For Example:

58WAV FURNACE INPUT BTUH	FREE AREA PER OPENING (SQ IN.)
44,000	100
66,000	100
88,000	100
110,000	110
132,000	132
154,000	154

- b. If the building is constructed unusually tight, a permanent opening directly communicating with the outdoors should be provided. This opening shall have a minimum free area of 1 sq in. per 5000 Btuh of total input rating for all equipment in the enclosure.
 - c. If the furnace is installed on a raised platform to provide a return-air plenum, and return air is taken directly from the hallway or space adjacent to the furnace, all air for combustion must come from outdoors.
2. All air from outside the structure:
 - a. If combustion air is taken from outdoors through vertical ducts, the openings and ducts **MUST** have at least 1 sq in. of free area per 4000 Btuh of the total input for all equipment within the confined space. (See Fig. 3.)
 - b. If combustion air is taken from the outdoors through horizontal ducts, the openings and ducts **MUST** have at least 1 sq in. of free area per 2000 Btuh of the total input for all equipment within the confined space.

For Example:

58WAV FURNACE INPUT BTUH	FREE AREA PER OPENING (SQ IN.)	ROUND PIPE (IN. DIA)
44,000	11.0	4
66,000	16.5	5
88,000	22.0	6
110,000	27.5	6
132,000	33.0	7
154,000	38.5	7

For Example:

58WAV FURNACE INPUT BTUH	FREE AREA PER OPENING (SQ IN.)	ROUND PIPE (IN. DIA)
44,000	22.0	6
66,000	33.0	7
88,000	44.0	8
110,000	55.0	9
132,000	66.0	10
154,000	77.0	10

- c. When ducts are used, they must be of the same cross-sectional area as the free area of the openings to which they connect. The minimum dimension of rectangular ducts must not be less than 3 in. (See Fig. 3.)

⚠ WARNING

Do not install the furnace on its back; safety control operation will be adversely affected. Never connect return-air ducts to the back of the furnace. A failure to follow this warning can cause a fire, personal injury, or death.

Step 3—Filter Arrangement

The factory-supplied filter(s) is shipped in the blower compartment. Determine location for the filter and relocate filter retaining wire if necessary. See Fig. 4 for side return application and Fig. 5 for bottom return application. See Table 3 to determine correct filter size for desired filter location. Table 3 indicates filter size, location, and quantity shipped with the furnace.

- For bottom air-return applications, filter may need to be cut to fit some furnace casing widths. A bottom closure panel is factory installed in the bottom of the furnace. When bottom return inlet is desired, remove and discard the bottom closure panel. Two sets of hardware are needed for furnaces in 24-1/2-in. wide casings using 2 filters for bottom return. All hardware is provided for filter installation.

NOTE: Furnaces with a 17-1/2-in. wide casing require an additional procedure when locating the filter for bottom return-air application. Field fabricate a sheet metal filler strip 1 X 3 X 24-1/2 in. and install it along side of the filter as shown in Fig. 5. Drive 2 screws through the casing side and into the filler strip to secure it in place. Filter should rest on the top of the filler strip when installed.

⚠ WARNING

Never operate unit without a filter or with filter access door removed. Failure to follow this warning can cause fire, personal injury, or death.

Step 4—Leveling Legs (If Required)

When the furnace is used with side inlet(s) and leveling legs are required, refer to Fig. 6, and install field-supplied, corrosion-resistant 5/16-in. machine bolts and nuts.

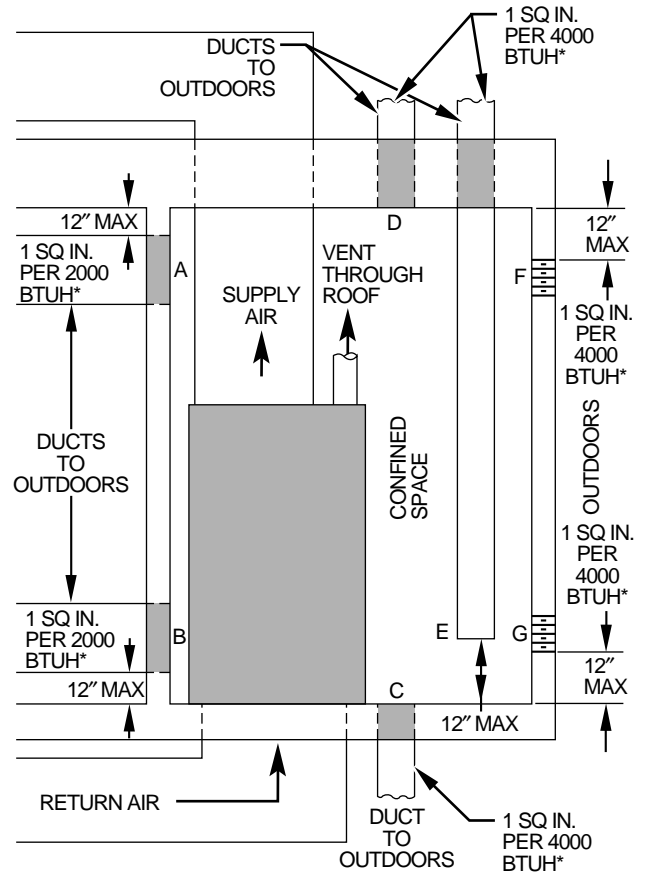

*Minimum dimensions of 3-in.

NOTE: Use any of the following combinations of openings: A & B C & D D & E F & G

A89013

Fig. 3—Air For Combustion and Ventilation (Outside Air)

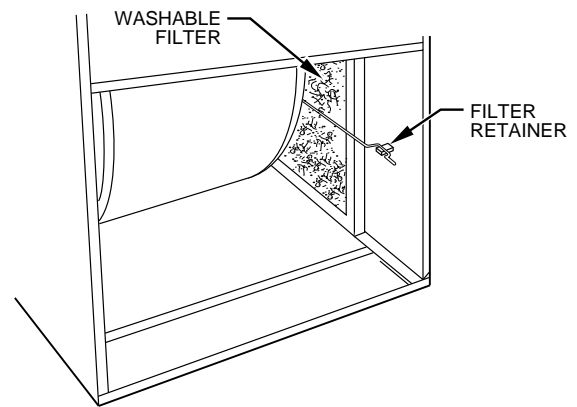

A93045

Fig. 4—Side Filter Arrangement (Control Removed for Clarity)

NOTE: The maximum length of the bolt should not exceed 1-1/2 in.

1. Lay furnace on its back. Locate and drill 5/16-in. diameter hole in each bottom corner of furnace as shown in Fig. 6.
2. Install nut on bolt and install bolt and nut in hole. (Install flat washer if desired.)
3. Install another nut on other side of furnace base. (Install flat washer if desired.)

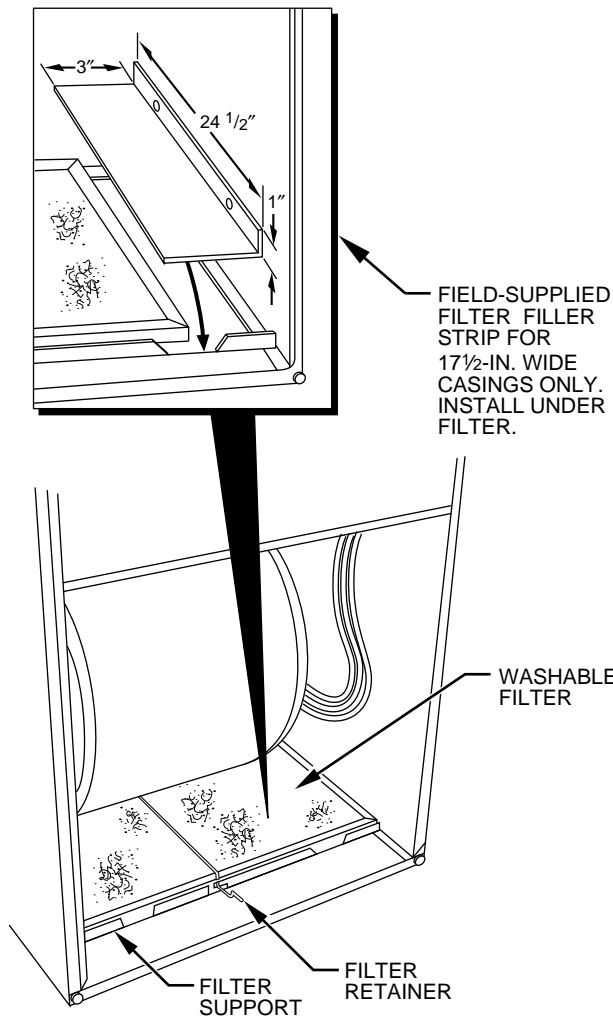

Fig. 5—Bottom Filter Arrangement (Control Removed for Clarity)

A93321

Table 3—Filter Information (In.)

FURNACE CASING WIDTH	FILTER SIZE*		FILTER TYPE
	Side Return	Bottom Return	
14-3/16	(1) 16 X 25 X 1†	(1) 14 X 25 X 1	Cleanable
17-1/2	(1) 16 X 25 X 1†	(1) 16 X 25 X 1	Cleanable
21	(1) 16 X 25 X 1	(1) 20 X 25 X 1†	Cleanable
24-1/2	(2) 16 X 25 X 1†	(1) 24 X 25 X 1	Cleanable

* Filters can be field modified by cutting the frame as marked and folding to the desired size. Alternate sizes can be ordered from your distributor or dealer.
 † Factory provided with the furnace.

- Adjust outside nut to provide desired height, and tighten inside nut to secure arrangement.

Step 5—Gas Piping

Gas piping must be installed in accordance with national and local codes. Refer to the current edition of the NFGC. Canadian installations must be installed in accordance with NSCNGPIC and all authorities having jurisdiction.

Refer to Table 4 for the recommended gas pipe size. Risers must be used to connect to the furnace and the meter.

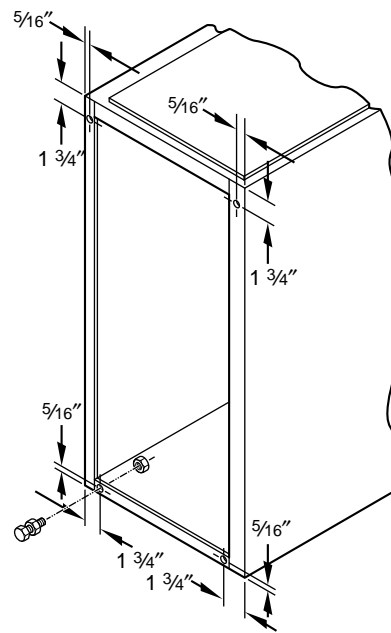

A89014

Fig. 6—Leveling Leg Installation

⚠ CAUTION

If a flexible connector is required or allowed by the authority having jurisdiction, black iron pipe shall be installed at the gas valve and extend a minimum of 2 in. outside the furnace casing.

Piping should be pressure tested in accordance with local and

Table 4—Maximum Capacity of Pipe*

NOMINAL IRON PIPE SIZE (IN.)	INTERNAL DIAMETER (IN.)	LENGTH OF PIPE (FT)				
		10	20	30	40	50
1/2	0.622	175	120	97	82	73
3/4	0.824	360	250	200	170	151
1	1.049	680	465	375	320	285
1-1/4	1.380	1400	950	770	660	580
1-1/2	1.610	2100	1460	1180	990	900

* Cubic ft of gas per hr for gas pressures of 0.5 psig (14-in. wc) or less, and a pressure drop of 0.5-in. wc (based on a 0.60 specific gravity gas). Ref: Table 10-2 NFPA 54-1992.

national plumbing and gas codes before the furnace has been attached. If the pressure exceeds 0.5 psig (14-in. wc), the gas supply pipe must be disconnected from the furnace and capped before the pressure test. If the test pressure is equal to or less than 0.5 psig (14-in. wc), close the manual shut-off valve located on the gas valve before the test. It is recommended that the ground joint union be loosened before pressure testing. After all connections have been made, purge the lines and check for leakage with regulated gas supply pressure.

Install a sediment trap in the riser leading to the furnace. The trap can be installed by connecting a tee to the riser leading from the furnace. Connect a capped nipple into the lower end of the tee. The capped nipple should extend below the level of the gas controls. (See Fig. 7.)

Apply joint compound (pipe dope) sparingly and only to the male threads of each joint. The compound must be resistant to the action of propane gas.

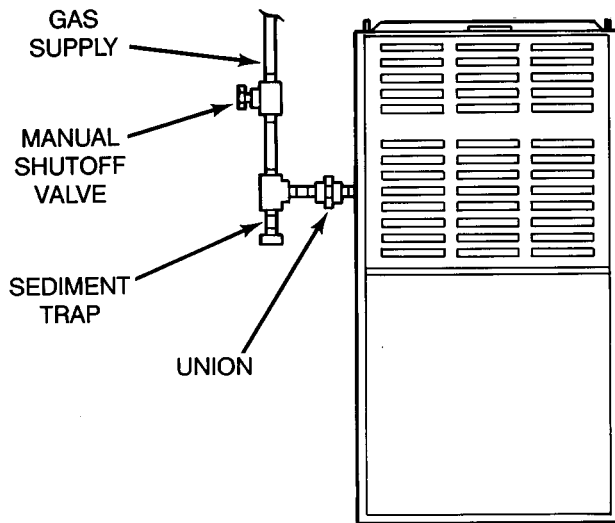

A89417

Fig. 7—Typical Gas Pipe Arrangement

Install an accessible manual shut-off valve upstream of the furnace gas controls and within 72 in. of the furnace. A 1/8-in. NPT plugged tapping, accessible for test gage connection, must be installed immediately upstream of the gas supply connection to the furnace and downstream of the manual shut-off valve. Place ground joint union between the gas control manifold and the manual shut-off valve.

⚠ WARNING

Use the proper length of pipes to avoid stress on the gas control manifold. Failure to follow this warning can result in a gas leak, causing fire, explosion, personal injury, or death.

⚠ CAUTION

Connect the gas pipe to the furnace using a backup wrench to avoid damaging gas controls.

⚠ WARNING

Never purge a line into a combustion chamber. Never use matches, candles, flame, or other sources of ignition for the purpose of checking leakage. Use a soap-and-water solution to check for leakage. Failure to follow this warning can cause a fire, explosion, personal injury, or death.

Step 6—Electrical Connections

115-V WIRING — Refer to the unit rating plate or Table 5 for equipment electrical requirements. The control system requires an earth ground for proper operation.

⚠ CAUTION

Do not connect aluminum wire between disconnect switch and furnace. Use only copper wire.

Make all electrical connections in accordance with the National Electrical Code (NEC) ANSI/NFPA 70-1993 and local codes or ordinances that might apply. For Canadian installations, all electrical connections must be made in accordance with CSA C22.1 Canadian Electrical Code, or authorities having jurisdiction.

⚠ WARNING

The cabinet **MUST** have an uninterrupted or unbroken ground according to NEC, ANSI/NFPA 70-1993 and Canadian Electrical Code, CSA C22.1 or local codes to minimize personal injury if an electrical fault should occur. This may consist of electrical wire or conduit approved for electrical ground when installed in accordance with existing electrical codes. Do not use gas piping as an electrical ground. Failure to follow this warning could result in electrical shock, fire, or death.

→ The auxiliary junction box (J-box) can be moved to the left-hand side of the furnace when a left-side power supply is desired. Remove the 2 screws holding the auxiliary J-box. Mount the J-box on the left-hand side of the furnace (holes have been pre-drilled in casing). When moved, tuck the wiring harness behind the clip provided to keep extra wire lengths out of the way.

NOTE: Proper polarity must be maintained for 115-v wiring. If polarity is incorrect, control board fault code indicator light will flash rapidly and the furnace will not operate.

24-V WIRING

Make field 24-v connections at the 24-v terminal strip. (See Fig. 9.) Connect terminal Y as shown in Fig. 8 for proper cooling operation. Use only AWG No. 18, color-coded, copper thermostat wire.

The 24-v circuit contains an automotive-type, 3-amp fuse located on the main control board. Any direct shorts during installation, service, or maintenance could cause this fuse to blow. If fuse replacement is required, use **ONLY** a 3-amp fuse of identical size.

ACCESSORIES

1. Electronic Air Cleaner (EAC)

Two spring clamp terminals (for 12 gage maximum, solid or stranded wire), marked EAC-1 and EAC-2 are provided for EAC connection. (See Fig. 9.) These terminals are energized with 115-v, (1-amp maximum) during blower motor operation. To connect EAC power leads to furnace control center, strip approximately 1/8 in. of insulation from wire. Open terminal by depressing switch arm with a screwdriver or finger, and insert wire as shown in Fig. 10.

2. Humidifier (HUM)

Screw terminals (HUM and Com) are provided for 24-v humidifier connection. The terminals are energized with 24-v 0.5-amp maximum after inducer motor prepurge period.

NOTE: A field-supplied, 115-v controlled relay connected to EAC terminals may be added if humidifier operation is desired during blower operation.

Step 7—Venting

Refer to the enclosed Installation Instructions, GAMA Venting Tables for Category I Furnaces and Venting Tables for Category I Fan-Assisted Furnaces. The horizontal portion of the venting system shall maintain a minimum of 1/4-in. upward slope per linear ft and it shall be rigidly supported every 5 ft or less with hangers or straps to ensure that there will be no movement after installation.

Step 8—Start-Up, Adjustment, and Safety Check

GENERAL

NOTE: Proper polarity must be maintained for 115-v wiring. If polarity is incorrect, control board fault indicator light will flash rapidly and furnace will not operate.

The furnace must have a 115-v power supply properly connected and grounded. Proper polarity must be maintained for correct

- - - - FIELD 24-VOLT WIRING
 - - - - FIELD 115-, 208/230-, 460-VOLT WIRING
 ———— FACTORY 24-VOLT WIRING
 ———— FACTORY 115-VOLT WIRING

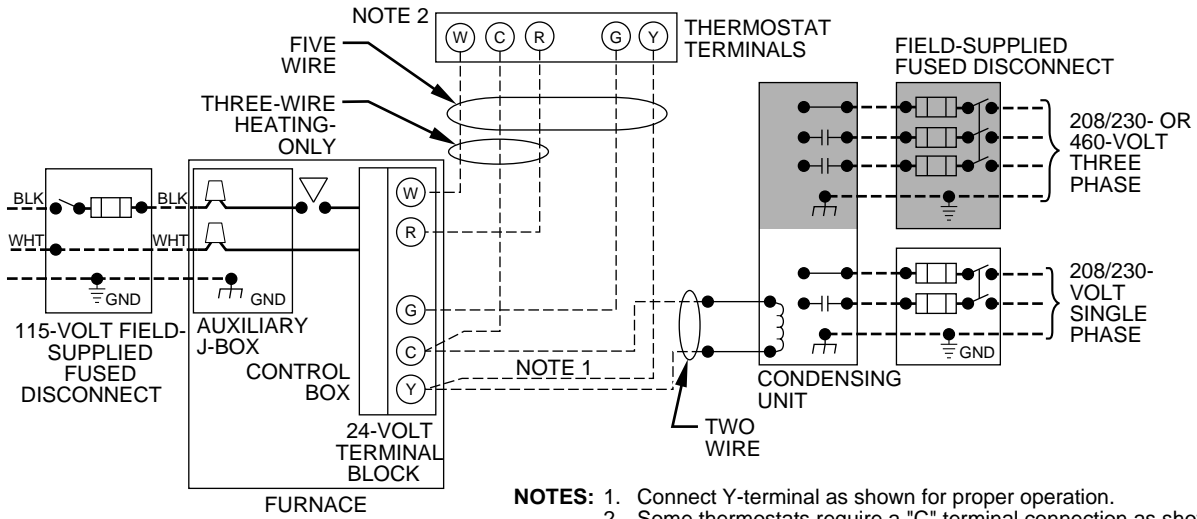

NOTES: 1. Connect Y-terminal as shown for proper operation.
 2. Some thermostats require a "C" terminal connection as shown.
 3. If any of the original wire, as supplied, must be replaced, use same type or equivalent wire.

A95241

→ Fig. 8—Heating and Cooling Application Wiring Diagram

Table 5—Electrical Data

UNIT SIZE	VOLTS—HERTZ—PHASE	OPERATING VOLTAGE RANGE		MAXIMUM UNIT AMPS	MINIMUM WIRE GAGE	MAXIMUM WIRE LENGTH (FT)‡	MAXIMUM FUSE OR HACR-TYPE CKT BKR AMPS†
		Maximum*	Minimum*				
045-08	115—60—1	127	104	6.0	14	47	15
045-12	115—60—1	127	104	8.3	14	34	15
070-08	115—60—1	127	104	5.9	14	47	15
070-12	115—60—1	127	104	8.7	14	32	15
091-14	115—60—1	127	104	9.0	14	31	15
091-16	115—60—1	127	104	10.4	14	27	15
111-12	115—60—1	127	104	8.0	14	35	15
111-16	115—60—1	127	104	10.1	14	28	15
111-20	115—60—1	127	104	14.4	12	31	20
136-16	115—60—1	127	104	10.1	14	28	15
136-20	115—60—1	127	104	13.3	12	33	20
155-20	115—60—1	127	104	14.0	12	31	20

* Permissible limits of the voltage range at which the unit operates satisfactorily.

† Time-delay fuse is recommended.

‡ Length shown is as measured 1 way along wire path between unit and service panel for maximum 2 percent voltage drop.

operation. Thermostat wire connections at R, W, C, and Y must be made at the 24-v terminal block on the control board. The gas service pressure must not exceed 0.5 psig (14-in. wc), but must be no less than 0.16 psig (4.5-in. wc).

⚠ CAUTION

This furnace is equipped with a manual reset limit switch or fuse link in the gas control area. The switch or fuse link opens and shuts off power to the gas valve if a flame rollout or overheating condition occurs in the gas control area. DO NOT bypass the switch. Correct inadequate combustion air supply problem and reset the switch or replace the fuse link.

Before operating the furnace, check each manual reset switch for continuity. If necessary, press the button to reset the switch.

The blower compartment door must be in place to complete the 115-v circuit to the furnace.

SEQUENCE OF OPERATION

⚠ CAUTION

Furnace control must be grounded for proper operation, or control will lockout. Control is grounded through green wire routed to gas valve and burner bracket screw.

Using the schematic diagram shown in Fig. 11, follow the sequence of operation through the different modes. Read and follow the wiring diagram very carefully.

NOTE: If there is a power interruption and any thermostat call, the control initiates a 90-sec blower only on period before starting another cycle.

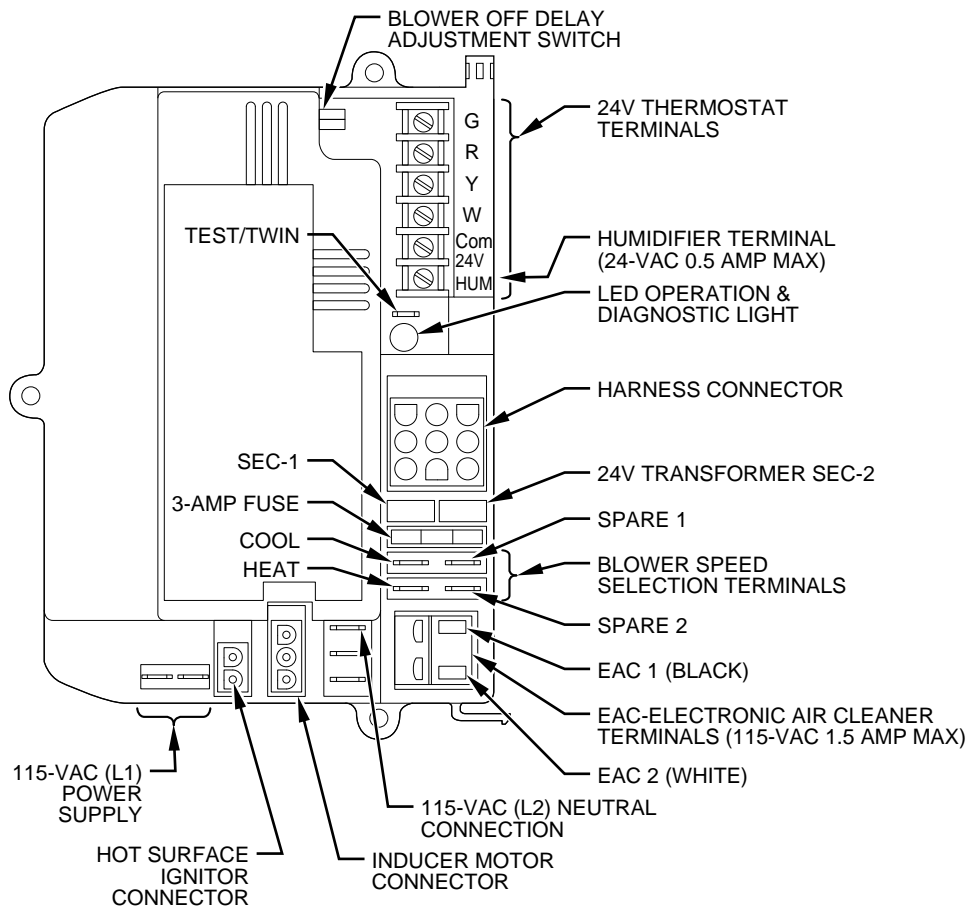

Fig. 9—Control Board

A93052

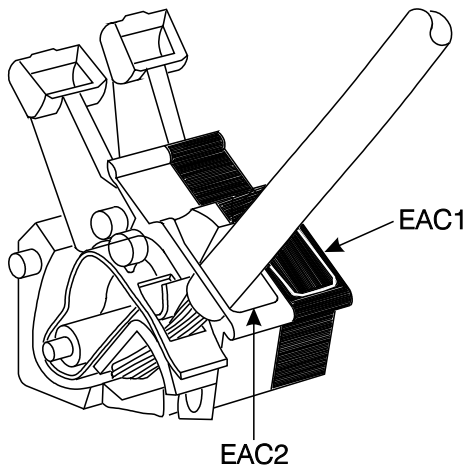

Fig. 10—EAC Terminals on Control Board

A93053

1. Heating mode

When the wall thermostat "calls for heat," the R-W circuit closes. The furnace control performs a self-check, verifies the pressure switch contacts are open, and starts inducer motor.

- a. Prepurge period—As the inducer motor comes up to speed, the pressure switch contacts close to begin a 15-sec prepurge period.
- b. Ignitor warm-up—At the end of the prepurge period, the ignitor is energized for a 17-sec ignitor warm-up period.
- c. Ignition sequence—When the ignitor warm-up period is completed, the gas valve opens, permitting gas flow to the

burners where it is ignited. After 5 sec, the ignitor is de-energized and a 2-sec flame-sensing period begins.

- d. HUM terminal is energized with the gas valve. See accessories in the Electrical Connections section.
- e. Flame-sensing—When burner flame is sensed, the control begins the blower on delay period and continues holding the gas valve open. If burner flame is not sensed, the control closes the gas valve and repeats ignition cycle.

NOTE: Ignition sequence will repeat 3 additional time before a lockout occurs. Lockout automatically resets after 3 hrs, or can be manually reset by turning 115v off (not at thermostat) for 3 sec minimum, then on again.

- f. Blower on delay—Forty sec after burner flame is proven, the blower motor is energized on heating speed. Simultaneously, the humidifier and electronic air cleaner terminals (HUM and Com for humidifier, EAC-1 and EAC-2 for electronic air cleaner) are energized. If jumper is on pin 6 and pin 9, blower on delay is 60 sec.
- g. Blower off delay—When the thermostat is satisfied, the circuit between R-W is broken, de-energizing the gas valve stopping gas flow to the burners. The blower motor and EAC remain energized 90, 135, 180, or 225 sec (depending on the blower off-time selection). The furnace is factory set for a 135-sec blower off delay.
- h. Post-purge—The inducer motor remains energized 5 sec after the burners are extinguished. If jumper is on pin 6 and pin 9, the post-purge period is 15 sec.

2. Cooling mode

When the thermostat "calls for cooling," R-G and R-Y circuits close. The R-Y circuit starts the outdoor condensing unit and

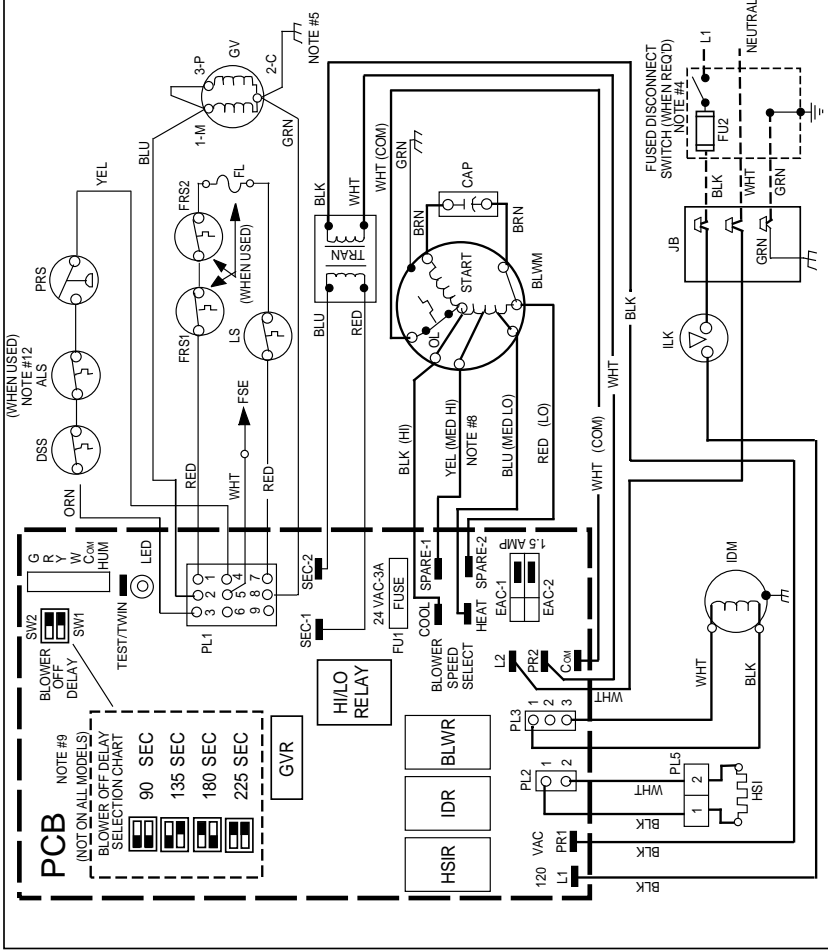
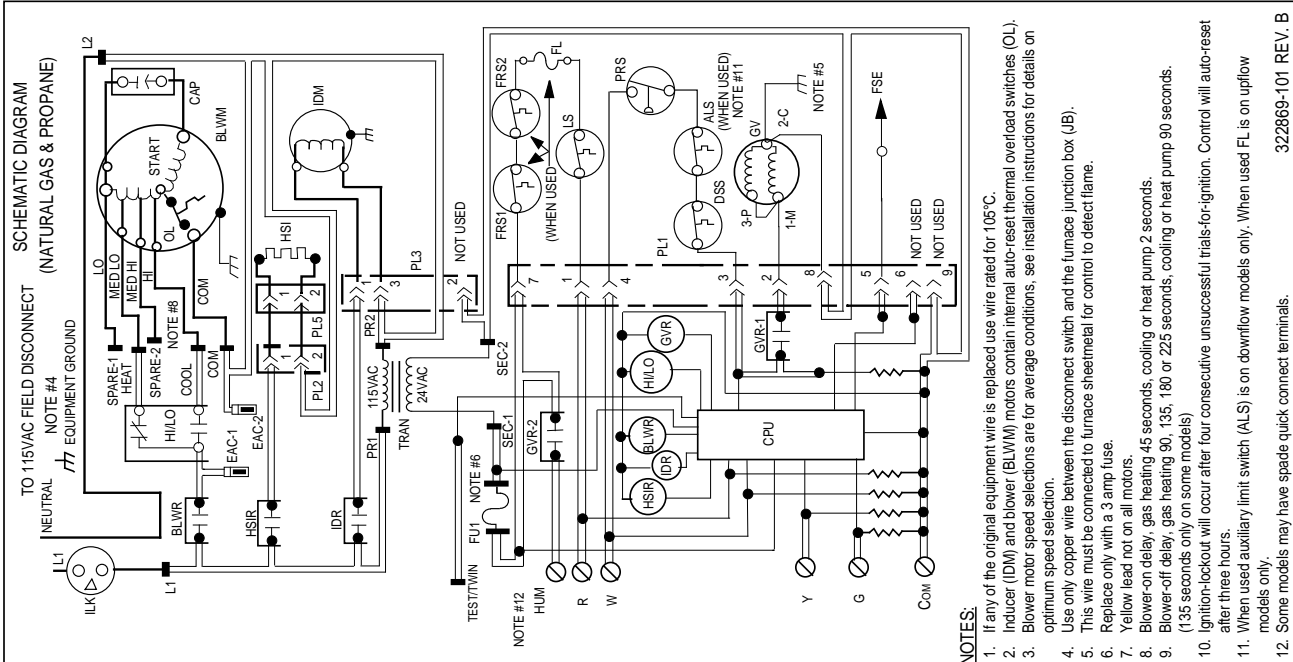

LEGEND

ALS	AUXILIARY LIMIT SWITCH, OVERTEMP -MANUAL RESET, SPST-(N.C.)
BLWR	BLOWER MOTOR RELAY, SPST-(N.O.)
BLWM	BLOWER MOTOR
CAP	CAPACITOR
CPU	MICROPROCESSOR AND CIRCUITRY
DSS	DRAFT SAFEGUARD SWITCH
EAC-1	ELECTRONIC AIR CLEANER CONNECTION (115 VAC, 1.5 AMP MAX.)
EAC-2	ELECTRONIC AIR CLEANER CONNECTION (COMMON)
FL	FUSIBLE LINK
FRS	FLAME ROLLOUT SW. -MANUAL RESET, SPST-(N.C.)
FSE	FLAME PROVING ELECTRODE
FU1	FUSE, 3 AMP, AUTO-RESET, BLADE TYPE, FACTORY INSTALLED
FU2	FUSE, 3 AMP, BREAKER, CURRENT INTERRUPT DEVICE (FIELD INSTALLED & SUPPLIED)
GV	GAS VALVE/REDUNDANT OPERATORS
GVR	GAS VALVE RELAY, DPST-(N.O.)
HILO	BLOWER MOTOR SPEED CHANGE RELAY, SPDT
HSI	HOT SURFACE IGNITOR (115 VAC)
HSIR	HOT SURFACE IGNITOR RELAY, SPST-(N.O.)
HUM	24VAC HUMIDIFIER CONNECTION (.5 AMP. MAX.)
IDM	INDUCED DRAFT MOTOR
IDR	INDUCED DRAFT RELAY, SPST-(N.O.)
ILK	BLOWER ACCESS PANEL INTERLOCK SWITCH, SPST-(N.O.)
JB	JUNCTION BOX
LED	LIGHT-EMITTING DIODE FOR STATUS CODES
LGPS	LOW GAS PRESSURE SWITCH, SPST-(N.O.)
LS	LIMIT SWITCH, AUTO RESET, SPST-(N.C.)
OL	AUTO-RESET INTERNAL MOTOR OVERLOAD TEMP. SW.

PCB	PRINTED CIRCUIT BOARD
PL1	9-CIRCUIT CONNECTOR
PL2	2-CIRCUIT PCB CONNECTOR
PL3	3-CIRCUIT IDM CONNECTOR
PL5	2-CIRCUIT HSI/PCB CONNECTOR
PRS	PRESSURE SWITCH, SPST-(N.O.)
TEST/TWIN	COMPONENT TEST & TWIN TERMINAL
TRAN	TRANSFORMER-115VAC/24VAC
●	JUNCTION
○	UNMARKED TERMINAL
□	PCB TERMINAL
—	FACTORY WIRING (115VAC)
- - -	FACTORY WIRING (24VAC)
· · ·	FIELD WIRING (115VAC)
· · ·	FIELD WIRING (24VAC)
—	CONDUCTOR ON PCB
—	FIELD WIRING TERMINAL
—	FIELD GROUND
—	EQUIPMENT GROUND
—	FIELD SPICE
—	PLUG RECEPTACLE

TO 115VAC FIELD DISCONNECT (NATURAL GAS & PROPANE)

PCB (NOT ON ALL MODELS)
 BLOWER OFF DELAY SELECTION CHART

90 SEC	[Symbol]
135 SEC	[Symbol]
180 SEC	[Symbol]
225 SEC	[Symbol]

- NOTES:**
1. If any of the original equipment wire is replaced use wire rated for 105°C.
 2. Inducer (IDM) and blower (BLWM) motors contain internal auto-reset thermal overload switches (OL).
 3. Blower motor speed selections are for average conditions, see installation instructions for details on optimum speed selection.
 4. Use only copper wire between the disconnect switch and the furnace junction box (JB).
 5. This wire must be connected to furnace sheetmetal for control to detect flame.
 6. Replace only with a 3 amp fuse.
 7. Yellow lead not on all motors.
 8. Blower-on delay, gas heating 45 seconds, cooling or heat pump 2 seconds.
 9. Blower-off delay, gas heating 90, 135, 180 or 225 seconds, cooling or heat pump 90 seconds. (135 seconds only on some models)
 10. Ignition-lockout will occur after four consecutive unsuccessful trials-for-ignition. Control will auto-reset after three hours.
 11. When used auxiliary limit switch (ALS) is on downflow models only. When used FL is on upflow models only.
 12. Some models may have spade quick connect terminals.

322869-101 REV. B

A95335

→ Fig. 11—Unit Wiring Diagram

the combined R-Y and R-G circuits start the furnace blower motor on cooling speed. The EAC-1 terminal is energized with 115v when the blower is operating on cooling speed.

When the thermostat is satisfied, R-G and R-Y circuits are broken. The furnace blower and EAC continue operating on cooling speed for an additional 90 sec.

3. Continuous blower mode

NOTE: EAC-1 terminal is energized with 115v whenever blower operates.

When the R-G circuit is made, the blower motor operates on heating speed. During a call for heat, the blower stops, allowing the furnace heat exchangers to heat up more quickly, then restarts at the end of the 40-sec blower on delay period. If jumper is on pin 6 and pin 9, the blower on delay is 60 sec.

The blower reverts to continuous operation after the heating cycle is completed.

When the thermostat "calls for cooling," the blower operates on cooling speed. When the thermostat is satisfied, the blower operates an additional 90 sec before reverting back to continuous operation on heating speed.

4. Heat pump mode

When installed with a heat pump, the furnace control automatically changes the timing sequence to avoid long blower off time during demand defrost cycles. When the W-Y or W-Y-G thermostat inputs are received at the same time, the control changes the blower to heating speed or starts the blower if it was off, and begins a heating cycle. The blower remains on until the end of the prepurge period, then shuts off until the end of the ignition warm-up and trial for ignition periods (a total of 24 sec). The blower then comes back on at heating speed.

When the W input signal disappears, the control begins the normal inducer post-purge period and the blower changes to cooling speed after a 1-sec delay. If the W-Y-G signals disappear at the same time, the blower remains on for the selected heating blower off delay period and the inducer goes through its normal post-purge period. If the W-Y inputs should disappear, leaving the G signal input, the control goes into continuous blower and the inducer remains on for the normal post-purge period.

Anytime the control senses false flame, the control locks out of the heating mode. This occurs because the control cannot sense the W input due to the false flame signal, and as a result, sees only the Y input and goes into cooling mode, blower off delay. All other control functions remain in standard format.

NOTE: EAC-1 terminal is energized whenever blower operates. HUM terminal is only energized when gas valve is energized

START-UP PROCEDURES

1. Purge gas lines—After all connections have been made, purge the lines and check for leaks.

⚠ WARNING

Never purge a line into a combustion chamber. Never use matches, candles, flame or other sources of ignition for the purpose of checking leakage. Use a soap-and-water solution to check for leakage. Failure to follow this warning can cause fire, explosion, personal injury, or death.

2. Component test—The furnace control board allows all components, except gas valve, to be run for a short period of time. This feature helps diagnose a system problem in case of a component failure. To initiate component test procedure, short

(jumper) the TEST 1/4-in. quick connect terminal on control board (adjacent to diagnostic light) and the Com terminal on thermostat connection block for approximately 2 sec. (See Fig. 9.)

NOTE: Component test feature will not operate if any thermostat signal is present at control board.

Component test sequence is as follows.

- a. Momentarily jumper TEST and Com terminals until LED goes off.
 - b. LED will display previous fault 4 times.
 - c. Inducer motor operates for 10 sec, then stops.
 - d. Hot surface ignitor is energized for 15 sec, then de-energized.
 - e. Blower motor operates on cooling speed for 10 sec, then stops.
 - f. Blower motor operates on heating speed for 10 sec, then stops.
3. To operate furnace, follow procedures on operating instructions label attached to furnace.
 4. With furnace operating, set thermostat below room temperature and observe that furnace goes off. Set thermostat above room temperature and observe that furnace restarts.

ADJUSTMENTS

1. Set gas input rate.

There are 2 methods of adjusting the gas input rate. The preferred method is by using Table 6 and following the instructions in item a. The second method is by clocking the gas meter and using the instructions in item b.

The gas valve regulator has been nominally set at 3.5-in. wc for natural gas. When adjusting input rate, do not set manifold pressure above 3.8-in. wc or below 3.2-in. wc.

- a. Check gas input rate using Table 6.
 - (1.) Obtain average yearly heat value for local gas supply.
 - (2.) Obtain average yearly specific gravity for local gas supply.
 - (3.) Verify furnace model. Table 6 can only be used for model 58WAV Furnaces.
 - (4.) Check and verify orifice size in furnace. NEVER ASSUME THE ORIFICE SIZE. ALWAYS CHECK AND VERIFY.
 - (5.) Find natural gas heat value and specific gravity in Table 6.
 - (6.) Follow heat value and specific gravity lines to point of intersection. Find orifice size and manifold pressure settings for proper operation at given natural gas conditions.

EXAMPLE:

Heat value 1070 Btu/cu ft

Specific gravity 0.58

Therefore; Orifice No. 44*

Manifold pressure 3.3-in. wc

* The furnace is shipped with No. 43 orifices.

Therefore, in this example all main burner orifices must be changed and manifold pressure must be adjusted.

- (7.) Proceed to item c to adjust manifold pressure.
- b. Check gas input rate by clocking gas meter.
 - (1.) Obtain average yearly heat value for local gas supply.

**Table 6—Model 58WAV Orifice Size and Manifold Pressure for Correct Input Rate
(Tabulated Data Based on Altitude Up to 2000 Ft and 22,000 Btuh Per Burner)**

GAS HEAT VALUE (BTU/CU FT)	SPECIFIC GRAVITY OF NATURAL GAS																	
	0.56		0.58		0.60		0.62		0.64		0.66		0.68		0.70		0.72	
	Orf No.	Mnflid Press.	Orf No.	Mnflid Press.	Orf No.	Mnflid Press.	Orf No.	Mnflid Press.	Orf No.	Mnflid Press.	Orf No.	Mnflid Press.	Orf No.	Mnflid Press.	Orf No.	Mnflid Press.	Orf No.	Mnflid Press.
860	41	3.2	41	3.3	41	3.4	41	3.5	41	3.7	41	3.8	39	3.4	38	3.2	38	3.3
	42	3.6	42	3.7	42	3.8	40	3.3	39	3.2	39	3.3	40	3.6	39	3.5	39	3.6
	—	—	—	—	40	3.2	—	—	40	3.4	40	3.5	—	—	40	3.7	40	3.8
875	42	3.4	41	3.2	41	3.3	41	3.4	41	3.5	41	3.6	41	3.8	39	3.3	38	3.2
	—	—	42	3.6	42	3.7	42	3.8	40	3.3	39	3.2	39	3.3	40	3.6	39	3.4
	—	—	—	—	—	—	40	3.2	—	—	40	3.4	40	3.5	—	—	40	3.7
890	42	3.3	42	3.4	41	3.2	41	3.3	41	3.4	41	3.5	41	3.6	41	3.7	41	3.8
	—	—	—	—	42	3.6	42	3.7	42	3.8	40	3.2	40	3.3	39	3.2	39	3.3
	—	—	—	—	—	—	—	—	—	—	—	—	—	—	40	3.4	40	3.5
905	42	3.2	42	3.3	42	3.4	41	3.2	41	3.3	41	3.4	41	3.5	41	3.6	41	3.7
	—	—	—	—	—	—	42	3.6	42	3.7	42	3.8	40	3.2	40	3.3	39	3.2
	—	—	—	—	—	—	—	—	—	—	—	—	—	—	—	—	40	3.4
920	43	3.8	42	3.2	42	3.3	42	3.4	41	3.2	41	3.3	41	3.4	41	3.5	41	3.6
	—	—	—	—	—	—	—	—	42	3.5	42	3.7	42	3.8	40	3.2	40	3.3
	—	—	—	—	—	—	—	—	—	—	—	—	—	—	—	—	—	—
935	43	3.7	43	3.8	42	3.2	42	3.3	42	3.4	41	3.2	41	3.3	41	3.4	41	3.5
	—	—	—	—	—	—	—	—	—	—	42	3.5	42	3.7	42	3.8	40	3.2
	—	—	—	—	—	—	—	—	—	—	—	—	42	3.5	42	3.6	42	3.7
950	43	3.6	43	3.7	43	3.8	42	3.2	42	3.3	42	3.4	41	3.2	41	3.3	41	3.4
	—	—	—	—	—	—	—	—	—	—	—	—	42	3.5	42	3.6	42	3.7
	—	—	—	—	—	—	—	—	—	—	—	—	—	—	42	3.5	42	3.6
965	43	3.4	43	3.6	43	3.7	43	3.8	42	3.2	42	3.3	42	3.4	41	3.2	41	3.3
	—	—	—	—	—	—	—	—	—	—	—	—	—	—	42	3.5	42	3.6
	—	—	—	—	—	—	—	—	—	—	—	—	—	—	—	—	—	—
980	44	3.8	42	3.5	43	3.6	43	3.7	43	3.8	42	3.2	42	3.3	42	3.4	41	3.2
	43	3.3	—	—	—	—	—	—	—	—	—	—	—	—	—	—	42	3.5
	—	—	—	—	—	—	—	—	—	—	—	—	—	—	—	—	—	—
995	44	3.7	44	3.8	43	3.5	43	3.6	43	3.7	43	3.8	42	3.2	42	3.3	42	3.4
	43	3.2	43	3.4	—	—	—	—	—	—	—	—	—	—	—	—	—	—
	—	—	—	—	—	—	—	—	—	—	—	—	—	—	—	—	—	—
1010	44	3.6	44	3.7	44	3.8	43	3.5	43	3.6	43	3.7	43	3.8	42	3.2	42	3.3
	—	—	43	3.3	43	3.4	—	—	—	—	—	—	—	—	—	—	—	—
	—	—	—	—	—	—	—	—	—	—	—	—	—	—	—	—	—	—
1025	44	3.5	44	3.6	44	3.7	43	3.4	43	3.5	43	3.6	43	3.7	43	3.8	43	3.2
	—	—	43	3.2	43	3.3	—	—	—	—	—	—	—	—	—	—	—	—
	—	—	—	—	—	—	—	—	—	—	—	—	—	—	—	—	—	—
1040	44	3.4	44	3.5	44	3.6	44	3.7	43	3.4	43	3.5	43	3.6	43	3.7	43	3.8
	—	—	—	—	43	3.2	43	3.3	—	—	—	—	—	—	—	—	—	—
	—	—	—	—	—	—	—	—	—	—	—	—	—	—	—	—	—	—
1055	44	3.3	44	3.4	44	3.5	44	3.6	44	3.8	43	3.4	43	3.5	43	3.6	43	3.7
	—	—	—	—	—	—	43	3.2	43	3.3	—	—	—	—	—	—	—	—
	—	—	—	—	—	—	—	—	—	—	—	—	—	—	—	—	—	—
1070	44	3.2	44	3.3	44	3.4	44	3.5	44	3.7	44	3.8	43	3.4	43	3.5	43	3.6
	—	—	—	—	—	—	—	—	43	3.2	43	3.3	—	—	—	—	—	—
	—	—	—	—	—	—	—	—	—	—	—	—	—	—	—	—	—	—
1085	45	3.8	44	3.2	44	3.3	44	3.4	44	3.6	44	3.7	44	3.8	43	3.4	43	3.5
	—	—	—	—	—	—	—	—	—	—	43	2.3	43	3.3	—	—	—	—
	—	—	—	—	—	—	—	—	—	—	—	—	—	—	—	—	—	—
1100	45	3.7	45	3.8	44	3.2	44	3.4	44	3.5	44	3.6	44	3.7	44	3.8	43	3.4
	—	—	—	3.4	—	—	—	—	—	—	—	—	43	3.2	43	3.3	—	—
	—	—	—	—	—	—	—	—	—	—	—	—	—	—	—	—	—	—

(2.) Check and verify orifice size in furnace. NEVER ASSUME THE ORIFICE SIZE. ALWAYS CHECK AND VERIFY.

⚠ CAUTION

DO NOT redrill burner orifices. Improper drilling (burrs, out of round, etc.) can cause excessive burner operating noise and misdirection of burner flames. This could result in flame impingement on burners and heat exchanger surfaces, leading to potential failures.

- (3.) Turn off all other gas appliances and pilots.
- (4.) Start furnace and let run for 3 minutes.
- (5.) Measure time (in sec) for gas meter to complete 1 revolution.
- (6.) Refer to Table 7 for cu ft of gas per hr.
- (7.) Multiply gas rate (cu ft/hr) by heating value (Btu/cu ft).

EXAMPLE:
 Btu heating input = Btu/cu ft X cu ft/hr
 Heating value of gas = 1070 Btu/cu ft
 Time for 1 revolution of 2 cu ft dial = 72 sec
 Gas rate = 100 X 1070 = 107,000 Btuh

- (8.) Measured gas input should not exceed gas input on unit rating plate.
- (9.) Proceed to item c to adjust manifold pressure.
- c. Adjust gas input.
 - (1.) Remove regulator adjustment seal cap. (See Fig. 12.)
 - (2.) Turn adjusting screw counterclockwise to decrease input. Turn screw clockwise to increase input. DO NOT set manifold pressure less than 3.2-in. wc or more than 3.8-in. wc for natural gas. Make any major adjustments by changing main burner orifices.
 - (3.) When correct input is obtained, replace regulator seal cap. Main burner flame should be clear blue, almost transparent. (See Fig. 13.)
- d. High altitude—In the United States gas input on rating plate is for altitudes up to 2000 ft. Ratings for altitudes over 2000 ft must be 4 percent less for each 1000 ft above sea

Table 7—Gas Rate Cu Ft/Hr

SECONDS FOR 1 REVOLUTION	SIZE OF TEST DIAL			SECONDS FOR 1 REVOLUTION	SIZE OF TEST DIAL		
	1 cu ft	2 cu ft	5 cu ft		1 cu ft	2 cu ft	5 cu ft
10	360	720	1800	50	72	144	360
11	327	655	1636	51	71	141	355
12	300	600	1500	52	69	138	346
13	277	555	1385	53	68	136	340
14	257	514	1286	54	67	133	333
15	240	480	1200	55	65	131	327
16	225	450	1125	56	64	129	321
17	212	424	1059	57	63	126	316
18	200	400	1000	58	62	124	310
19	189	379	947	59	61	122	305
20	180	360	900	60	60	120	300
21	171	343	857	62	58	116	290
22	164	327	818	64	56	112	281
23	157	313	783	66	54	109	273
24	150	300	750	68	53	106	265
25	144	288	720	70	51	103	257
26	138	277	692	72	50	100	250
27	133	267	667	74	48	97	243
28	129	257	643	76	47	95	237
29	124	248	621	78	46	92	231
30	120	240	600	80	45	90	225
31	116	232	581	82	44	88	220
32	113	225	563	84	43	86	214
33	109	218	545	86	42	84	209
34	106	212	529	88	41	82	205
35	103	206	514	90	40	80	200
36	100	200	500	92	39	78	196
37	97	195	486	94	38	76	192
38	95	189	474	96	38	75	188
39	92	185	462	98	37	74	184
40	90	180	450	100	36	72	180
41	88	176	439	102	35	71	178
42	86	172	429	104	35	69	173
43	84	167	419	106	34	68	170
44	82	164	409	108	33	67	167
45	80	160	400	110	33	65	164
46	78	157	391	112	32	64	161
47	76	153	383	116	31	62	155
48	75	150	375	120	30	60	150
49	73	147	367				

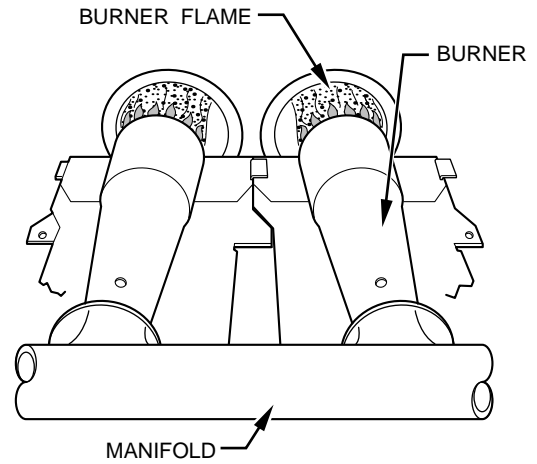

A89020

Fig. 13—Burner Flame

orifices as needed. Refer to National Fuel Gas Code Appendix F, Table F-4 for proper orifice sizing at high altitudes.

- e. Canadian installations only—The Canadian ratings are approved for altitudes up to 2000 ft for natural and propane gases. High-altitude ratings are from 2000 ft to 4500 ft above sea level. See Table 8 for nominal burner orifice size. High-altitude rating includes a 10 percent derate as required by Canadian standards.

Table 8—Canadian Orifice Size

GAS	SEA LEVEL 0—2000 FT	HIGH ALTITUDE 2000—4500 FT
Natural	43	44
Propane	54	55

2. Set temperature rise.

Furnace must operate within range of temperature rise specified on the unit rating plate. Determine the air temperature rise as follows.

- a. Place duct thermometers in return and supply ducts as near furnace as possible. Be sure thermometers do not "see" heat exchangers so that radiant heat will not affect thermometer readings. This is particularly important with straight-run ducts.
- b. When thermometer readings stabilize, subtract return-air temperature from supply-air temperature to determine temperature rise.
- c. Adjust air temperature rise by adjusting blower speed. Increase blower speed to reduce temperature rise. Decrease blower speed to increase temperature rise.

⚠ WARNING

Disconnect the electrical power before changing the speed tap. A failure to follow this warning can cause personal injury.

- d. To change blower motor speed selections for heating mode, remove blower motor lead from control board HEAT terminal. (See Fig. 11.) Select desired blower motor speed lead from 1 of the other terminals and relocate it to HEAT terminal. See Table 9 for lead color identification. Reconnect original lead on SPARE terminal.

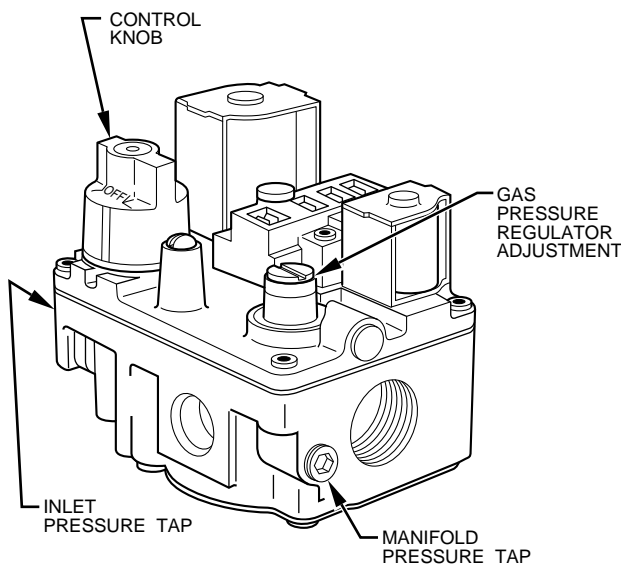

A90044

Fig. 12—Redundant Automatic Gas Control Valve

level. To obtain the adjusted altitude rating, adjust the manifold pressure (see item c) and replace the main burner

Table 9—Speed Selector

COLOR	SPEED	FACTORY ATTACHED TO
Black	High	COOL
Yellow (When present)	Medium-High	SPARE
Blue	Medium-Low	HEAT
Red	Low	SPARE
White	Common	COM

⚠ CAUTION

Recheck temperature rise. It must be within limits specified on unit rating plate. Recommended operation is at midpoint of rise or above.

3. Set thermostat heat anticipator.

The thermostat heat anticipation must be set to match the amp draw of the electrical components in the R-W circuit. Accurate amp draw readings can be obtained at thermostat subbase terminals R and W. Fig. 14 illustrates an easy method of obtaining the actual amp draw. The amp reading should be taken after the blower motor has started. See the thermostat manufacturer's instructions for adjusting the heat anticipator and for varying the heating cycle length.

NOTE: When using an electronic thermostat, set the cycle rate for 3 cycles per hr.

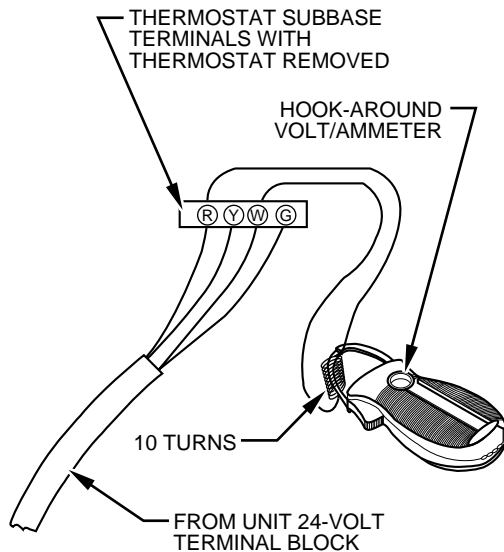

EXAMPLE: $\frac{5.0 \text{ AMPS ON AMMETER}}{10 \text{ TURNS AROUND JAWS}} = 0.5 \text{ AMPS FOR THERMOSTAT SETTING}$

A80201

Fig. 14—Amp Draw Check With Ammeter

CHECK SAFETY CONTROLS — The flame sensor, gas valve, and pressure switch were all checked in the Start-Up Procedures section as part of normal operation.

1. Check primary limit control.

This control shuts off the combustion control system and energizes the circulating-air blower motor if the furnace overheats.

The preferred method of checking the limit control is to gradually block off the return air after the furnace has been operating for a period of at least 5 minutes. As soon as the limit has shut off the burners, the return-air opening should be unblocked. By using this method to check the limit control, it can be established that the limit is functioning properly and operates if there is a motor failure.

2. Check draft safeguard switch.

The purpose of this control is to permit the safe shutdown of the furnace during certain blocked vent conditions.

- Disconnect power to furnace and remove vent connector from furnace outlet collar. Be sure to allow time for vent pipe to cool down before removing.
- Restore power to furnace and set room thermostat above room temperature.
- After normal start-up, allow furnace to operate for 2 minutes, then block flue outlet 100 percent. Furnace should cycle off within 2 minutes.
- Remove blockage and reconnect vent pipe to furnace outlet collar.
- Wait 5 minutes and then reset draft safeguard switch.

3. Check pressure switch.

This control proves operation of draft inducer blower.

- Turn off 115-v power to furnace.
- Remove control door and disconnect inducer motor lead wires from wire harness.
- Turn on 115-v power to furnace.
- Set thermostat to "call for heat" and wait 1 minute. When pressure switch is functioning properly, hot surface ignitor should NOT glow and control center diagnostic light flashes a 31 fault. If hot surface ignitor glows when inducer motor is disconnected, shut down furnace immediately. Determine reason pressure switch did not function properly and correct condition.
- Turn off 115-v power to furnace.
- Reconnect inducer motor wires, replace control door, and turn on 115-v power.

CHECKLIST

- Put away tools, instruments, and clean up debris.
- Verify manual reset switches have continuity.
- Ensure blower and control access doors are properly installed.
- Cycle test furnace with room thermostat.
- Check operation of accessories per manufacturer's instructions.
- Review User's Manual with owner.
- Leave literature packet near furnace.