

Installation Instructions

Vent Terminal Kit

KGAVT0101BRA
KGAVT0201BRA



NOTE: Read the entire instruction manual before starting the installation.
This symbol → indicates a change since the last issue.

SAFETY CONSIDERATIONS

Installing and servicing heating equipment can be hazardous due to gas and electrical components. Only trained personnel should install or service heating equipment.

Recognize safety information. This is the safety-alert symbol . When you see this symbol on the furnace and in instructions or manuals, be alert to the potential for personal injury.

→ Understand the signal words DANGER, WARNING, CAUTION, and NOTE. These words are used with the safety-alert symbol. DANGER identifies the most serious hazards which **will** result in severe personal injury or death. WARNING signifies a hazard that **could** result in personal injury or death. CAUTION is used to identify unsafe practices which **may** result in minor personal injury or product and property damage. NOTE is used to highlight suggestions that **will** result in enhanced installation, reliability, or operation.

Untrained personnel can perform basic maintenance functions such as cleaning coils, or cleaning and replacing filters. All other operations should be performed by trained service personnel. When working on heating equipment, observe precautions in the literature, on tags, and on labels attached to the unit.

Follow all safety codes. Wear safety glasses and work gloves. Have a fire extinguisher available.

WARNING: ELECTRICAL SHOCK HAZARD

Failure to follow this warning could result in personal injury or death.

Before beginning any installation or modification, be sure the main electrical disconnect switch is in the OFF position.

The kit contains the following items:

Kit contains the following items:

Vent terminal bracket	1
Installation Instructions	1

INTRODUCTION

This instruction covers installation of the Vent Terminal Kit, Part No. KGAVT0101BRA and KGAVT0201BRA, on all upflow and downflow gas-fired condensing furnaces.

NOTE: If these instructions differ from those packaged with the furnace, follow these instructions.

DESCRIPTION AND USAGE

Two terminal kits are available. The 2-in. kit 1-1/2-in. and 2-in. diameter pipe systems. The 3-in. kit is for 2-1/2-in., 3-in. and 4-in. diameter pipe systems. (See Fig. 3, 4, and 5 for the different applications). The combustion-air and vent pipes must terminate outside the structure. This termination kit must be installed as in one of the installations shown in Fig. 3, 4, or 5. The roof termination is preferred.

Field-supplied pipe and fittings are required to complete the installation. Elbows used with the terminal bracket must conform to the dimensions shown in Fig. 2.

The combustion-air and vent pipe fittings must conform to American National Standards Institute (ANSI) and American Society for Testing and Materials (ASTM) standards D1785 (schedule-40 PVC), D2665 (PVC-DWV), D2441 (SDR-21 and SDR-26 PVC), D2661 (ABS-DWV), or F628 (schedule-40 ABS). Pipe cement and primer must conform to ASTM standards D2564 (PVC) or D2235 (ABS).

In Canada, construct all combustion-air and vent pipes for this unit of CSA or ULC certified schedule-40 PVC, PVC-DWV, or ABS-DWV pipe and pipe cement. SDR pipe is not approved in Canada.

For sidewall terminations, a Vent Terminal Cover Kit (Part No. KGAVT0301COV and KGAVT0401COV) is available to improve the termination appearance. Refer to the Vent Terminal Cover Kit instructions for additional information.

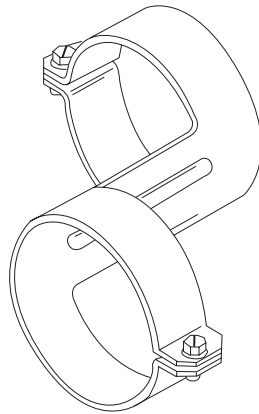

A90002

Fig. 1—Vent Terminal Bracket

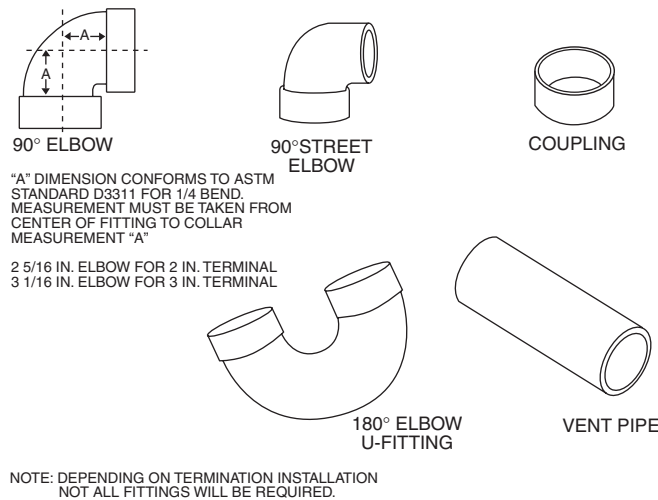

A90001

Fig. 2—Field-Supplied Pipe and Fittings

INSTALLATION

PROCEDURE 1—ROOF TERMINATION (PREFERRED)

1. Loosely install elbow in bracket and place assembly on combustion-air pipe.
2. Loosely install pipe coupling on properly cut vent pipe. The coupling must be positioned so the bracket will mount as shown in Fig. 3.
3. Disassemble loose pipe fittings. Clean and cement using procedures found in installation literature packaged with furnace.
4. Install bracket as shown in Fig. 3
5. For applications using combustion-air pipe option, indicated by dashed lines in Fig. 3, install 90° street elbow into 90° elbow, making U-fitting. A 180° U-fitting may be used. (See Fig. 2.)

PROCEDURE 2—SIDE WALL TERMINATION

COMBUSTION-AIR AND VENT PIPES EXIT THROUGH SIDEWALL 12-IN. OR MORE ABOVE HIGHEST ANTICIPATED SNOW LEVEL OR GRADE

1. Install elbows as shown in Fig. 4 using procedures for cementing found in installation literature packaged with furnace.
2. Install bracket as shown in Fig. 4.
3. Position vent pipe and elbow to maintain vertical 12-in. separation between vent pipe outlet and combustion-air inlet. Cement vent pipe in elbow as shown in Fig. 4.
4. For applications using vent pipe option indicated by dashed lines in Fig. 4, rotate vent elbow 90° from position shown in Fig. 4.

PROCEDURE 3—SIDE WALL TERMINATION

COMBUSTION-AIR AND VENT PIPES EXIT THROUGH SIDEWALL LESS THAN 12-IN. ABOVE HIGHEST ANTICIPATED SNOW LEVEL OR GRADE

1. Install one elbow in bracket.
2. Install 90° street elbow into elbow in bracket, making U-fitting, or use 180° U-fitting. (See Fig. 2.)
3. Loosely install coupling on end of vent pipe.
4. Loosely install U-fitting and bracket as shown in Fig. 5. Position U-fitting so open end is against structure wall.

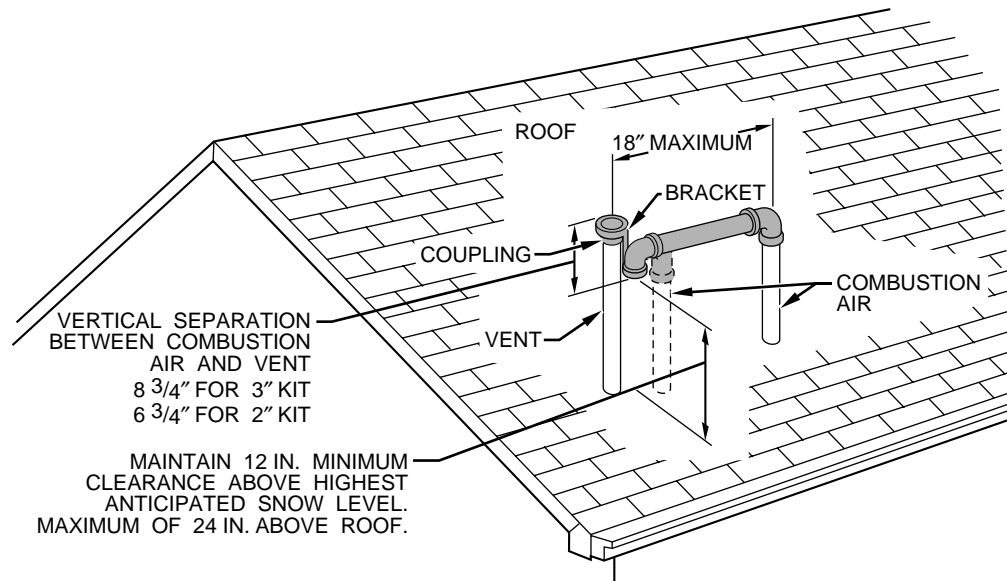

A87224

Fig. 3— Roof Termination (Preferred)

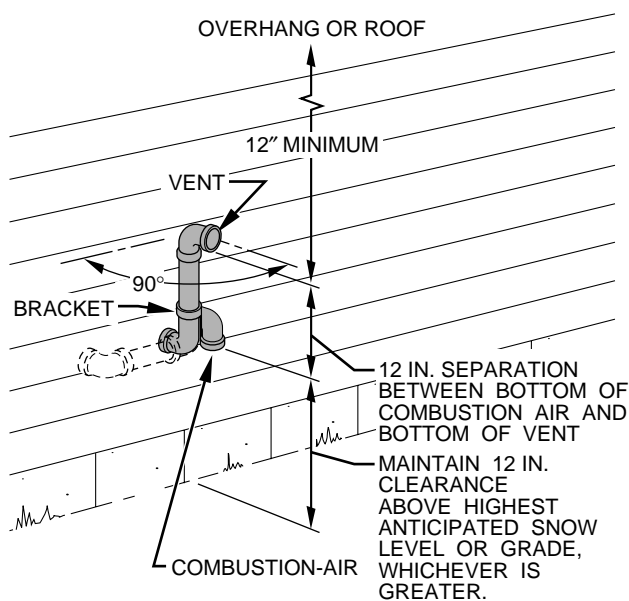

A87225

Fig. 4—Sidewall Termination (12-in. or more above snow level and grade)

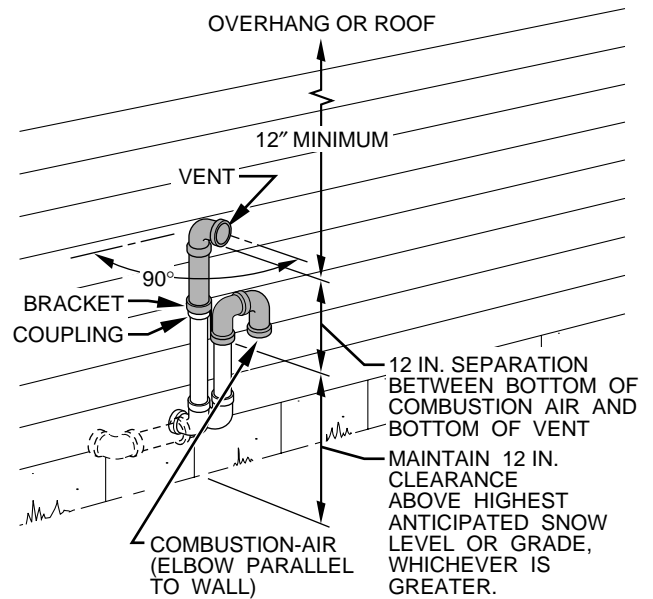

A87226

Fig. 5—Sidewall Termination (less than 12-in. above snow level or grade)

5. Loosely install vent outlet pipe and elbow in coupling as shown in Fig. 5.
6. Check required dimensions as shown in Fig. 5.
7. Disassemble loose pipe fittings. Clean and cement using procedures found in installation literature packaged with furnace.
8. Install bracket as shown in Fig. 5.

