

Two-pieces shipping

TSA-16	Main shell				HT Generator				Solution	
	L1	W1	H1	Weight	L2	W2	H2	Weight	Weight	Bottle
	mm	mm	mm	kg	mm	mm	mm	kg		
DJ-51	5,070	2,300	2,970	11,800	3,750	1,420	2,950	4,300	3,900	12
DJ-52	5,610	2,300	2,970	12,600	3,940	1,420	2,950	4,600	4,400	13
DJ-53	6,110	2,300	2,970	13,400	4,140	1,420	2,950	4,900	4,800	14
DJ-61	5,740	2,650	3,410	17,700	4,380	1,450	3,380	6,400	5,900	17
DJ-62	6,240	2,650	3,410	18,900	4,680	1,450	3,380	6,900	6,500	19
DJ-63	6,760	2,650	3,410	20,000	5,030	1,450	3,380	7,500	7,300	21
DJ-71	6,510	2,820	3,520	23,200	5,180	1,640	3,500	8,900	8,900	26
DJ-72	7,040	2,820	3,520	24,800	5,700	1,640	3,500	9,700	9,700	28
DJ-73	7,540	2,820	3,520	26,000	6,000	1,640	3,500	10,300	10,500	30
DJ-81	7,030	2,940	3,720	27,900	6,190	1,810	3,700	11,400	11,600	33
DJ-82	7,530	2,940	3,720	29,300	6,390	1,810	3,700	11,900	12,500	35

- Note) 1) Above dimensions are not included packing size.
 2) Control panel is shipped with main shell.
 3) Solution bottle size is 600 x 600 x 950mm.
 The solution weight is included bottle weight.

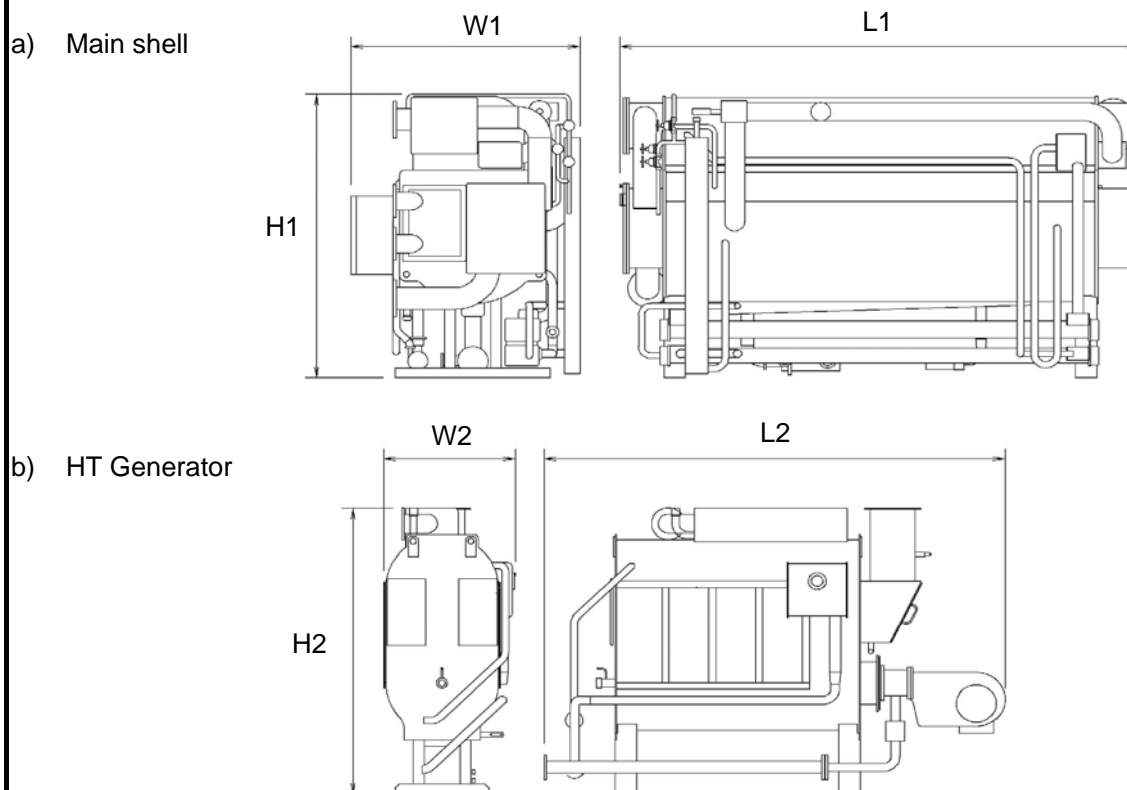

Carrier
SANYO

**Shipping dimensions
 (Two-pieces shipping)**

Model

TSA-16DJ

Drawing code

DJ-008-131-22-0