

## Two-pieces shipping

TSA-16	Main shell				HT Generator				Solution	
	L1 inch	W1 inch	H1 inch	Weight lb	L2 inch	W2 inch	H2 inch	Weight lb	Weight lb	Bottle
DJ-51	200	91	117	26,100	148	56	117	9,500	8,600	12
DJ-52	221	91	117	27,800	156	56	117	10,200	9,800	13
DJ-53	241	91	117	29,600	163	56	117	10,900	10,600	14
DJ-61	226	105	135	39,100	173	58	134	14,200	13,100	17
DJ-62	246	105	135	41,700	185	58	134	15,300	14,400	19
DJ-63	267	105	135	44,100	199	58	134	16,600	16,100	21
DJ-71	257	112	139	51,200	204	65	138	19,700	19,700	26
DJ-72	278	112	139	54,700	225	65	138	21,400	21,400	28
DJ-73	297	112	139	57,400	237	65	138	22,800	23,200	30
DJ-81	277	116	147	61,600	244	72	146	25,200	25,600	33
DJ-82	297	116	147	64,700	252	72	146	26,300	27,600	35

- Note) 1) Above dimensions are not included packing size.  
 2) Control panel is shipped with main shell.  
 3) Solution bottle size is 24 x 24 x 38 inch.  
 The solution weight is included bottle weight.

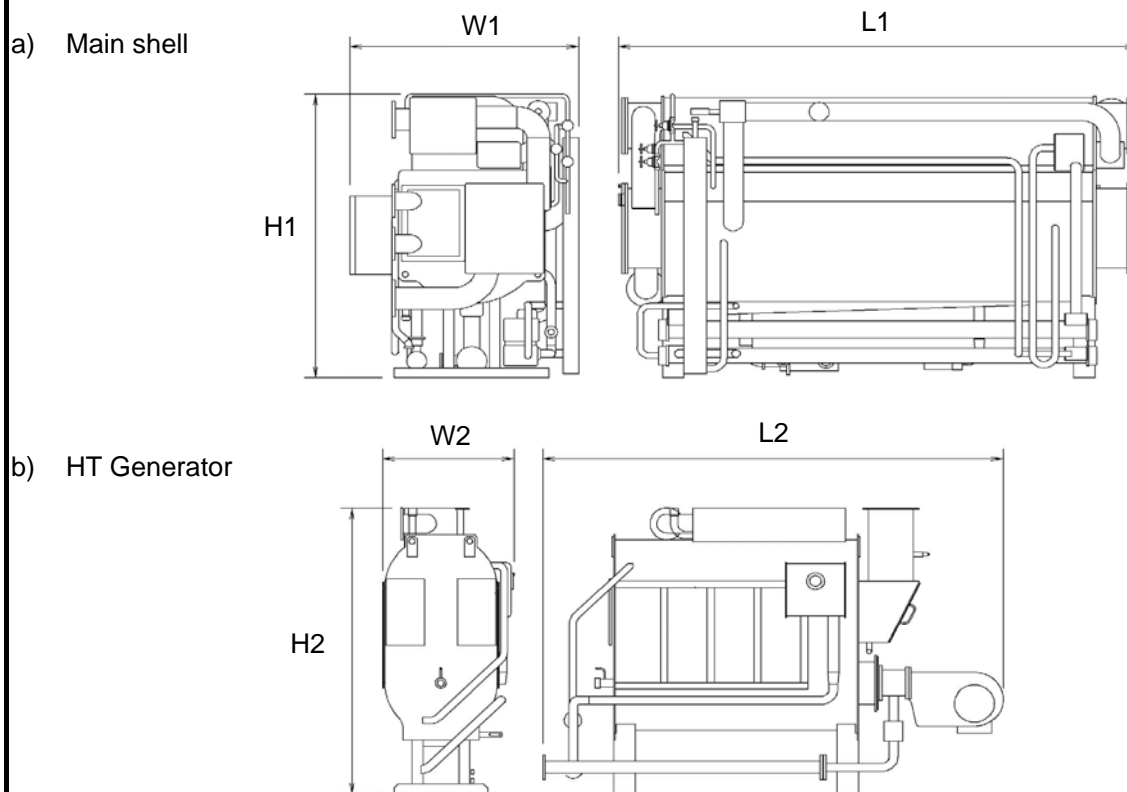

**Carrier**  
**SANYO**

**Shipping dimensions  
 (Two-pieces shipping)**

Model

**TSA-16DJ**

Drawing code

**DJ-008-131-27-0**