

# Application Data

## TABLE OF CONTENTS

	PAGE
SAFETY CONSIDERATIONS .....	1
PART NUMBERS .....	1
APPLICABLE UNITS .....	1
GENERAL .....	2
DESCRIPTIONS .....	2
FEATURES .....	3
INDICATORS .....	3
TYPICAL CONTROL WIRING .....	5
ADDITIONAL FUNCTIONS WITH ROOFTOP UNITS .....	6
SENSOR AND CONTROLLER TESTS .....	9
DETECTOR CLEANING .....	10
TROUBLESHOOTING .....	11
GUIDE SPECIFICATIONS .....	12
UNIT SPECIFIC DATA .....	13

## SAFETY CONSIDERATIONS

**IMPORTANT:** This equipment will provide safe and reliable service when operated within design specifications. The equipment should be operated and serviced only by authorized personnel who have a thorough knowledge of system operation, safety devices and emergency procedures.

Good judgement should be used in applying any manufacturer's instructions to avoid injury to personnel or damage to equipment and property.

Follow all safety codes. Wear safety glasses and work gloves. Use quenching cloth for unbrazing operations. Have fire extinguishers available for all brazing operations.

Recognize safety information. This is the safety-alert symbol . When you see this symbol on the furnace and in instructions or manuals, be alert to the potential for personal injury.

Understand the signal words DANGER, WARNING, and CAUTION. These words are used with the safety-alert symbol. DANGER identifies the most serious hazards which **will** result in severe personal injury or death. WARNING signifies a hazard which **could** result in personal injury or death. CAUTION is used to identify unsafe practices which **may** result in minor personal injury or product and property damage. NOTE is used to highlight suggestions which **will** result in enhanced installation, reliability, or operation.

## WARNING

### ELECTRICAL SHOCK HAZARD

Failure to follow this warning could cause personal injury or death.

Disconnect all power to the unit before performing maintenance or service. Unit may automatically start if power is not disconnected. Tag disconnect switch with lockout tag.

## PART NUMBERS

HK28ZT001	Controller module
HK50ZT001	Sensor module with exhaust tube
RN20ZT008	8-in. sample tube
RN20ZT024	24-in. sample tube
RN20ZT036	36-in. sample tube
RN20ZT042	42-in. sample tube
KA99ZT003	SD-TRK4 remote test-reset station, keyed

## APPLICABLE UNITS

48/50HE, 50HEQ003-006	581C, 551C, 549C024-060
50HJQ, TFQ004-006	548F, 549F036-102
48/50HJ, TM004-014	581B, 551B036-300
48/50TF, 004-014, TJ016-028	580F, 558F036-300
48/50PG03-28	
48/50HG014-028	

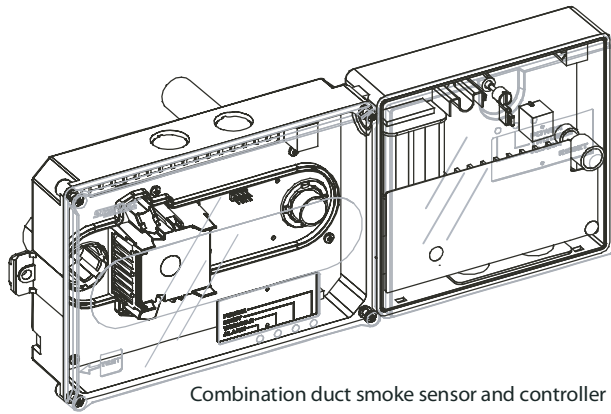

Combination duct smoke sensor and controller

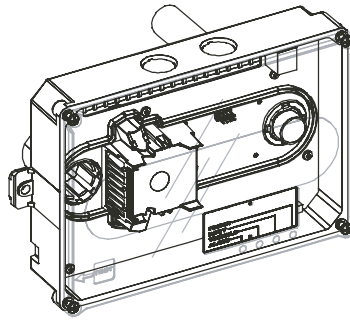

Duct smoke sensor

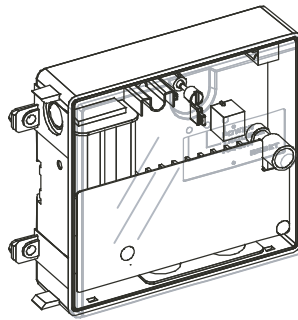

Duct smoke sensor controller

**Fig. 1 - Controller and Detector**

C07284

## GENERAL

This document provides information and guidance on smoke detectors that are factory installed on the applicable units.

For field installed smoke detector applications, these same detectors may be used. However, unless a field installed kit is provided, the installer must determine and install the detectors in a manner consistent with the application and in compliance with all codes. Due to the wide variety of both of these issues, field installation kits are not available for all unit models.

The primary intent of these detectors is to shut down the unit's air delivery services upon an alarm trip. They are not designed as a substitute for an open area smoke detector nor a substitute for early warning detection or a replacement for a building's regular fire detection system. Smoke detectors are not designed to detect toxic gases which can build up to hazardous levels in some fires. These devices will not operate without electrical power. As fires frequently cause power interruptions, it is recommended that the installer further safeguards with your local fire protection specialist and code enforcement agency.

## DESCRIPTIONS

### Controller

The controller includes a controller housing, a printed circuit board, and a clear plastic cover. The controller can be connected to one or two compatible duct smoke sensors. The clear plastic cover is secured to the housing with a single captive screw for easy access to the wiring terminals. (See Fig. 1, 3, and 4.)

### Sensor

The sensor includes a plastic housing, a printed circuit board, a clear plastic cover, an exhaust tube, and a sampling tube. The exhaust tube and sampling tube are attached during installation. The sampling tube varies in length depending on the size of the rooftop unit. The clear plastic cover permits visual inspections without having to disassemble the sensor. The cover attaches to the sensor housing using four captive screws and forms an airtight chamber around the sensing electronics.

### System

The smoke detector comprises a four-wire controller and one or two sensors. Its primary function is to shut down the rooftop unit in order to prevent smoke from circulating throughout the building. It is not to be used as a life saving device. When these smoke detectors are factory installed on the units listed above, no additional sampling tubes are required to be field installed. (See Fig. 5.)

The controller is designed for multiple operating voltages and provides relay contacts for connection to fire alarm systems, HVAC controls, and other auxiliary functions. A remote test/reset station can be connected to the controller to provide these functions.

For installations using two sensors, the duct smoke detector does not differentiate which sensor signals an alarm or trouble condition. The sensor uses a process called differential sensing to prevent gradual environmental changes from triggering false alarms. A rapid change in environmental conditions, such as smoke from a fire, causes the sensor to signal an alarm state but dust and debris accumulated over time does not.

Air is introduced to the duct smoke detector's sensing chamber through a sampling tube that extends into the HVAC duct and is directed back into the ventilation system through an exhaust tube. The difference in air pressure between the two tubes pulls the sampled air through the sensing chamber. When a sufficient amount of smoke is detected in the sensing chamber, the sensor signals an alarm state and the controller automatically takes the appropriate action to shut down fans and blowers, change over air handling systems, notify the fire alarm control panel, etc.

CAUTION

**EQUIPMENT DAMAGE HAZARD**

Failure to follow this caution may result in damage to equipment.

Excess temperature differentials between the ambient air and the sampled air can produce unwanted condensation inside the sensor, which may cause the sensor to function improperly. Precautions should be taken to limit the temperature range and the amount of condensation to which the sensor is exposed.

## FEATURES

The smoke sensor incorporates the following features:

- Environmental compensation with differential sensing for reliable, stable, and drift-free sensitivity.
- Magnet-activated test/reset switch on sensors.
- PCB mounted photoelectric sensor with on-board intelligence.
- Cover tamper switch for added security.
- Alarm, Trouble, Dirty, and Power status LEDs. (See Table 1 and Fig. 2.)
- Extended temperature and air velocity ranges.
- Capable of adding an additional sensors (for a total of two) using the same controller.
- Multiple operating voltages.
- No tools required to access field connection terminals.
- Recessed momentary switch for test/reset of the detector.
- One set of normally open alarm initiation contacts for connection to an initiating device circuit on a fire alarm control panel.
- Two Form-C auxiliary alarm relays for interface with rooftop unit or other equipment.
- One Form-C supervision (trouble) relay to control the operation of the Trouble LED on a remote test/reset station.
- Can be wired to up to 14 other duct smoke detectors for multiple fan shutdown applications.

## INDICATORS

### Normal State

The smoke detector operates in the normal state in the absence of any trouble conditions and when its sensing chamber is free of smoke. In the normal state, the Power LED on both the sensor and the controller are on and all other LEDs are off.

## Alarm State

The smoke detector enters the alarm state when the amount of smoke particulate in the sensor's sensing chamber exceeds the alarm threshold value. (See Table 1.) Upon entering the alarm state:

- The sensor's Alarm LED and the controller's Alarm LED turn on.
- The contacts on the controller's two auxiliary relays switch positions.
- The contacts on the controller's alarm initiation relay close.
- The controller's remote alarm LED output is activated (turned on).
- The controller's high impedance multiple fan shutdown control line is pulled to ground Trouble state.

The SuperDuct duct smoke detector enters the trouble state under the following conditions:

- A sensor's cover is removed and 20 minutes pass before it is properly secured.
- A sensor's environmental compensation limit is reached (100% dirty).
- A wiring fault between a sensor and the controller is detected.

An internal sensor fault is detected upon entering the trouble state:

- The contacts on the controller's supervisory relay switch positions. (See Fig. 3.)
- If a sensor trouble, the sensor's Trouble LED the controller's Trouble LED turn on.
- If 100% dirty, the sensor's Dirty LED turns on and the controller's Trouble LED flashes continuously.
- If a wiring fault between a sensor and the controller, the controller's Trouble LED turns on but not the sensor's.

**NOTE:** All troubles are latched by the duct smoke detector. The trouble condition must be cleared and then the duct smoke detector must be reset in order to restore it to the normal state.

## Multiple Detector Operation

The interconnect feature of the smoke detector allows up to 15 smoke detectors to be connected to each other, typically for multiple fan shutdown applications. When one of the smoke detectors goes into alarm, it operates as described above. On the remaining smoke detectors not in alarm, only the following occurs:

- The auxiliary relay contacts switch positions.
- The remote LED output is activated (turned on).

**Table 1 – Detector Indicators**

Control or Indicator	Description
Magnetic test/reset switch	Resets the sensor when it is in the alarm or trouble state. Activates or tests the sensor when it is in the normal state.
Alarm LED	Indicates the sensor is in the alarm state.
Trouble LED	Indicates the sensor is in the trouble state.
Dirty LED	Indicates the amount of environmental compensation used by the sensor (flashing continuously = 100%)
Power LED	Indicates the sensor is energized.

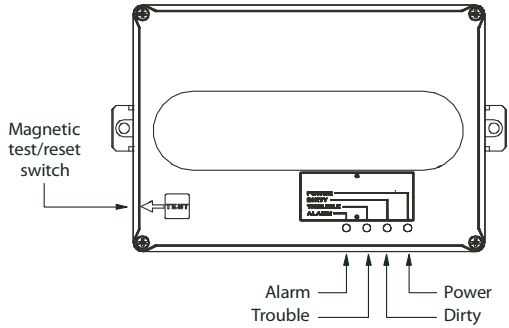

**Fig. 2 - Detector Assembly**

C07297

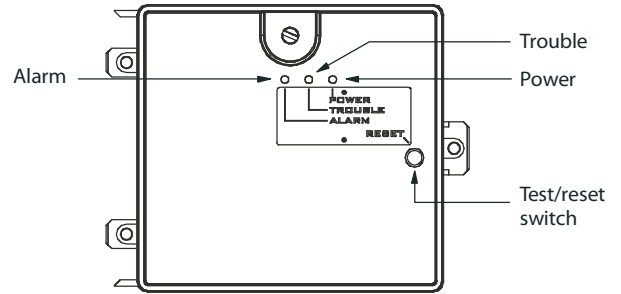

**Fig. 3 - Controller Assembly**

C07298

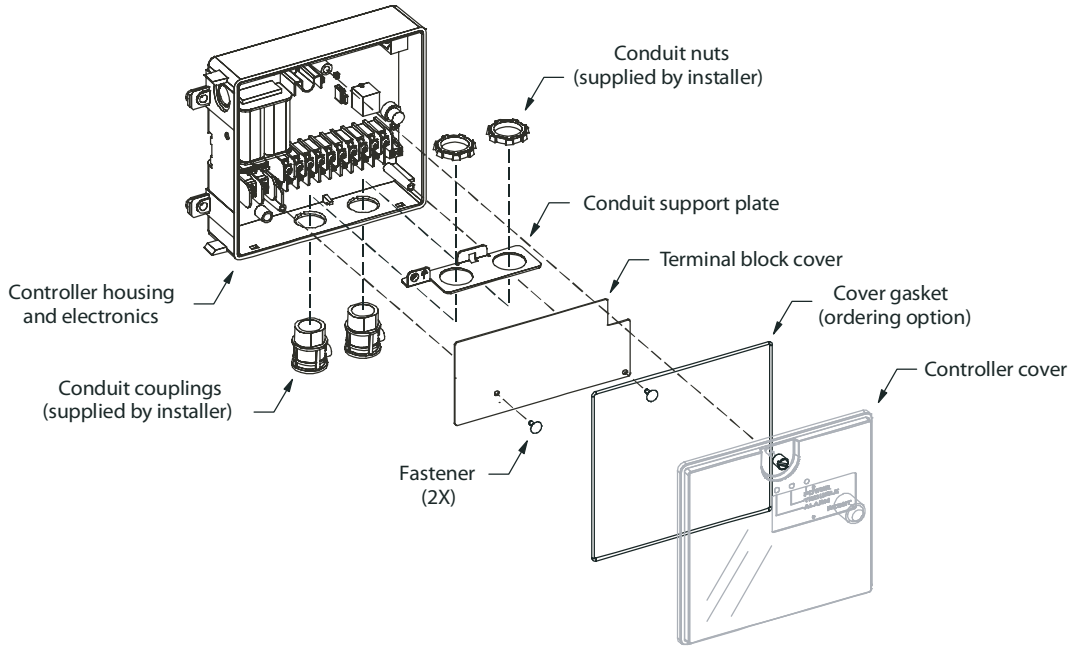

**Fig. 4 - Controller Exploded View**

C07299

**HKRNKA**



**Table 2 – Terminal Block Connections**

Terminal No.	Name	Terminal No.	Name
1	AUX (-)	11	Not Used
2	Reset	12	Multi – Shutdown
3	SUPV Contact COM	13	SUPV Contact NO
4	Alarm Contact COM	14	SUPV Contact NC
5	Alarm Contact NO	15	REM Alarm LED Out
6	AUX 1 Contact COM	16	AUX 1 Contact NC
7	AUX 2 Contact NO	17	AUX 1 Contact NO
8	AUX 2 Contact NC	18	AUX 2 Contact COM
9	24V AC/DC In (+)	19	18 VDC Output (+)
10	24V AC/DC In (-)	20	18 VDC Output (-)
N	AC Neutral	TB3-1	Not Used
L	AC Line	TB3-2	Not Used

## ADDITIONAL FUNCTIONS WITH ROOFTOP UNITS

The factory installed smoke detectors are factory wired to immediately shut down the unit upon an alarm trip. However, in many situations, additional functions such as remote test stations, remote indicators, and auxiliary relays are also desired or required by code. These functions are easily supported by the factory installed smoke detector; however, since they typically involve incorporation with the building system and exact details are frequently application specific, these additional functions must be wired in the field.

As shown in Table 1, additional functionality includes but is not limited to the functions below. Fig. 6-11 show typical wiring integration to allow integration of the smoke detectors with various other building systems. For the remote indication and/or test station, the Remote Keyed Attenuator SD-TRK4 (p/n KA99ZT00)3 is recommended. See Fig. 9 and guide specification section.

- Building alarm initiation
- Remote indicators
- Multiple fan shutdown
- Remote test station
- Auxiliary relays

The smoke detector system is also frequently desired to be integrated into rooftop unit for the following functions:

- Smoke purge
- Pressurization
- Smoke Exhaust

These functions are typically only required after an alarm has been initiated. They require integration with the unit economizer and/or power exhaust and are typically activated at the specific request of the fire department. See the applicable unit wiring diagrams for guidance specifics on these functions with respect to the unit in question.

### Smoke Purge

Smoke Purge is the operation of the unit’s indoor fan to bring air in the building and push air out the building, supplemented by a Power Exhaust. Since the Outdoor Air (OA) damper blades and the Return Air (RA) damper blades move in opposite directions, this feature results in the OA dampers fully open and the RA dampers fully shut.

### Pressurization and Smoke Exhaust

Pressurization and Smoke Exhaust are typically used together when there are multiple units on application. The Fire Marshall places the rooftop unit for the affected zone in the Smoke Exhaust mode and all others in the Pressurization mode, thus clearing the smoke in the affected zone. Pressurization is the operation of the unit’s indoor fan to create a positive pressure inside the building by fully opening the OA dampers and turning on the indoor fan. Since the OA damper blades and the RA damper blades move in opposite directions, this feature results in the OA dampers fully open and the RA dampers fully shut. Smoke Exhaust is very similar to Smoke Purge, except that this function requires the economizer OA dampers to be fully shut and the Power Exhaust to be on. Since the OA damper blades and the RA damper blades move in opposite directions (for Carrier economizers), this feature results in the OA dampers fully shut and the RA dampers fully open.

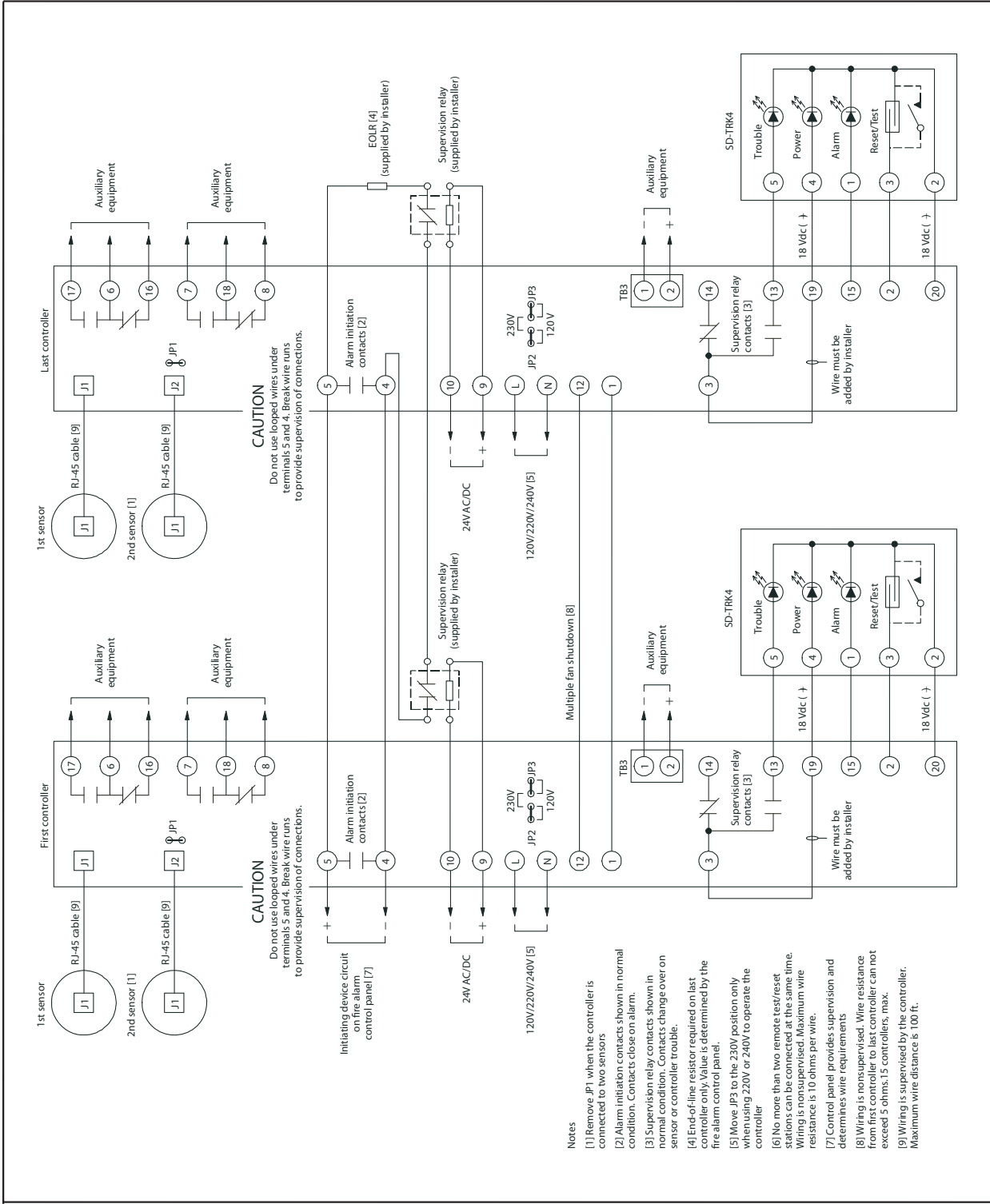

**CAUTION**  
Do not use looped wires under terminals 5 and 4. Break wire runs to provide supervision of connections.

**CAUTION**  
Do not use looped wires under terminals 5 and 4. Break wire runs to provide supervision of connections.

- Notes
- [1] Remove JP1 when the controller is connected to two sensors
  - [2] Alarm initiation contacts shown in normal condition. Contacts close on alarm.
  - [3] Supervision relay contacts shown in normal condition. Contacts change over on sensor or controller trouble.
  - [4] End-of-line resistor required on last controller only. Value is determined by the fire alarm control panel.
  - [5] Move JP3 to the 230V position only when using 220V or 240V to operate the controller
  - [6] No more than two remote test/reset stations can be connected at the same time. Wiring is non-supervised. Maximum wire resistance is 10 ohms per wire.
  - [7] Control panel provides supervision and determines wire requirements
  - [8] Wiring is non-supervised. Wire resistance from all contacts to last controller can not exceed 5 ohms. 5 controllers, max.
  - [9] Wiring is supervised by the controller. Maximum wire distance is 100 ft.

Fig. 8 - Typical Smoke Detector System Wiring



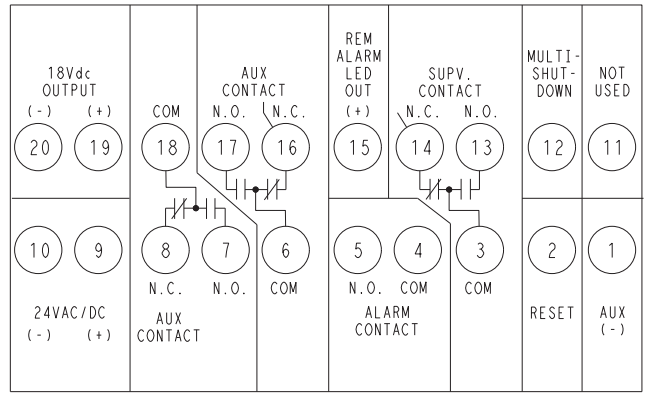
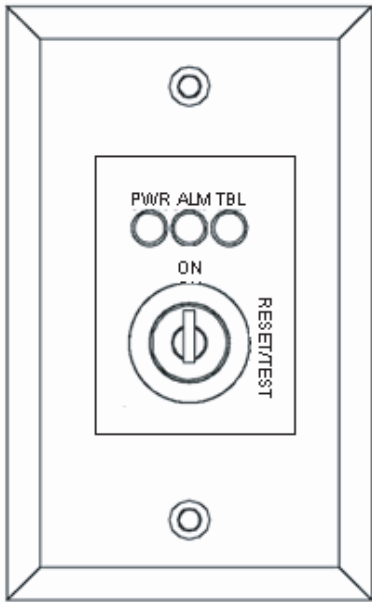
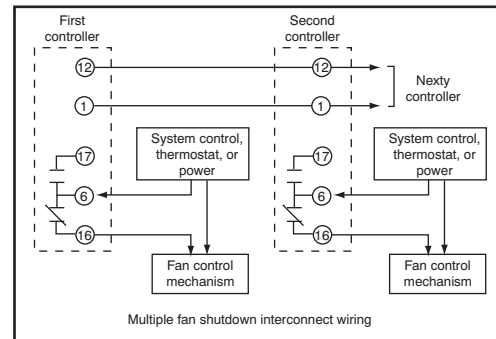
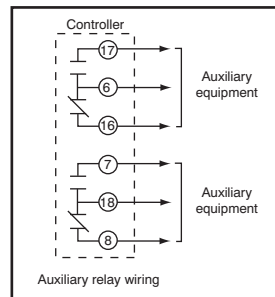
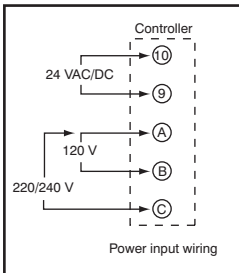
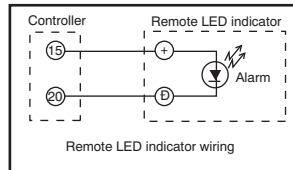
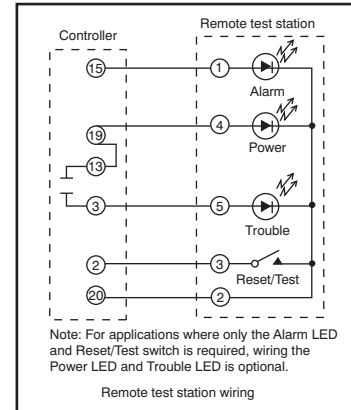
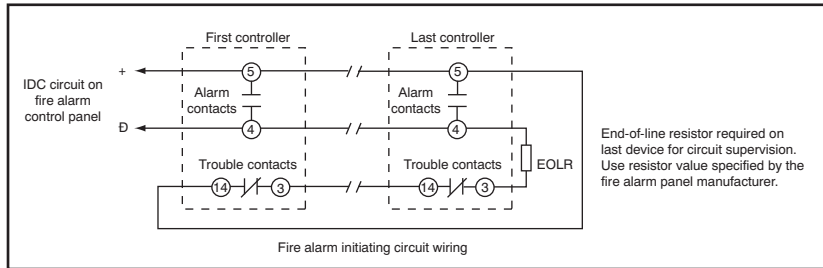

**Fig. 10 - Controller TB3 Connections**

C07318

**Fig. 9 - Remote Keyed Actuator**

C07317



**Fig. 11 - Typical Smoke Detector Wiring - Exploded View**

C07319

## SENSOR AND CONTROLLER TESTS

### Sensor Alarm Test

The sensor alarm test checks a sensor's ability to signal an alarm state. This test requires that you use a field provided SD-MAG test magnet.

#### ⚠ CAUTION

##### OPERATIONAL TEST HAZARD

Failure to follow this caution may result in personnel and authority concern.

This test places the duct detector into the alarm state. Unless part of the test, disconnect all auxiliary equipment from the controller before performing the test. If the duct detector is connected to a fire alarm system, notify the proper authorities before performing the test.

### Sensor Alarm Test Procedure

1. Hold the test magnet where indicated on the side of the sensor housing for seven seconds.
2. Verify that the sensor's Alarm LED turns on.
3. Reset the sensor by holding the test magnet against the sensor housing for two seconds.
4. Verify that the sensor's Alarm LED turns off.

### Controller Alarm Test

The controller alarm test checks the controller's ability to initiate and indicate an alarm state.

#### ⚠ CAUTION

##### OPERATIONAL TEST HAZARD

Failure to follow this caution may result in personnel and authority concern.

This test places the duct detector into the alarm state. Disconnect all auxiliary equipment from the controller before performing the test. If the duct detector is connected to a fire alarm system, notify the proper authorities before performing the test.

### Controller Alarm Test Procedure

1. Press the controller's test/reset switch for seven seconds.
2. Verify that the controller's Alarm LED turns on.
3. Reset the sensor by pressing the test/reset switch for two seconds.
4. Verify that the controller's Alarm LED turns off.

### Dirty Controller Test

The dirty controller test checks the controller's ability to initiate a dirty sensor test and indicate its results.

#### ⚠ CAUTION

##### OPERATIONAL TEST HAZARD

Failure to follow this caution may result in personnel and authority concern.

Pressing the controller's test/reset switch for longer than seven seconds will put the duct detector into the alarm state and activate all automatic alarm responses.

### Dirty Controller Test Procedure

1. Press the controller's test/reset switch for two seconds.
2. Verify that the controller's Trouble LED flashes.

### Dirty Sensor Test

The dirty sensor test provides an indication of the sensor's ability to compensate for gradual environmental changes. A sensor that can no longer compensate for environmental changes is considered 100% dirty and requires cleaning or replacing. You must use a field provided SD-MAG test magnet to initiate a sensor dirty test. The sensor's Dirty LED indicates the results of the dirty test as shown in Table 3.

#### ⚠ CAUTION

##### OPERATIONAL TEST HAZARD

Failure to follow this caution may result in personnel and authority concern.

Holding the test magnet against the sensor housing for more than seven seconds will put the duct detector into the alarm state and activate all automatic alarm responses.

Table 3 – Dirty LED Test

Flashes	Description
1	0–25% dirty. (Typical of a newly installed detector)
2	25–50% dirty
3	51–75% dirty
4	76–99% dirty

### Dirty Sensor Test Procedure

1. Hold the test magnet where indicated on the side of the sensor housing for two seconds.
2. Verify that the sensor's Dirty LED flashes.

### Changing the Dirt Sensor Test

By default, sensor dirty test results are indicated by:

- The sensor's Dirty LED flashing.
- The controller's Trouble LED flashing.
- The controller's supervision relay contacts toggle.

The operation of a sensor's dirty test can be changed so that the controller's supervision relay is not used to indicate test results. When two detectors are connected to a controller, sensor dirty test operation on both sensors must be configured to operate in the same manner.

#### ⚠ CAUTION

##### OPERATIONAL TEST HAZARD

Failure to follow this caution may result in personnel and authority concern.

Changing the dirty sensor test operation will put the detector into the alarm state and activate all automatic alarm responses. Before changing dirty sensor test operation, disconnect all auxiliary equipment from the controller and notify the proper authorities if connected to a fire alarm system.

### To Configure the Dirty Sensor Test Operation

1. Hold the test magnet where indicated on the side of the sensor housing until the sensor's Alarm LED turns on and its Dirty LED flashes twice (approximately 60 seconds).
2. Reset the sensor by removing the test magnet then holding it against the sensor housing again until the sensor's Alarm LED turns off (approximately 2 seconds).

### **Remote Station Test**

The remote station alarm test checks a test/reset station's ability to initiate and indicate an alarm state.

## **⚠ CAUTION**

### **OPERATIONAL TEST HAZARD**

Failure to follow this caution may result in personnel and authority concern.

This test places the duct detector into the alarm state. Unless part of the test, disconnect all auxiliary equipment from the controller before performing the test. If the duct detector is connected to a fire alarm system, notify the proper authorities before performing the test.

### SD-TRK4 Remote Alarm Test Procedure

1. Turn the key switch to the RESET/TEST position for seven seconds.
2. Verify that the test/reset station's Alarm LED turns on.
3. Reset the sensor by turning the key switch to the RESET/TEST position for two seconds.
4. Verify that the test/reset station's Alarm LED turns off.

### **Remote Test/Reset Station Dirty Sensor Test**

The test/reset station dirty sensor test checks the test/reset station's ability to initiate a sensor dirty test and indicate the results. It must be wired to the controller as shown in Fig. 8 and configured to operate the controller's supervision relay. For more information, see "Changing sensor dirty test operation."

## **⚠ CAUTION**

### **OPERATIONAL TEST HAZARD**

Failure to follow this caution may result in personnel and authority concern.

If the test/reset station's key switch is left in the RESET/TEST position for longer than seven seconds, the detector will automatically go into the alarm state and activate all automatic alarm responses.

## **⚠ CAUTION**

### **OPERATIONAL TEST HAZARD**

Failure to follow this caution may result in personnel and authority concern.

Holding the test magnet to the target area for longer than seven seconds will put the detector into the alarm state and activate all automatic alarm responses.

### Dirty Sensor Test Using an SD-TRK4

1. Turn the key switch to the RESET/TEST position for two seconds.
2. Verify that the test/reset station's Trouble LED flashes.

## **DETECTOR CLEANING**

### **Cleaning the Smoke Detector**

Clean the duct smoke sensor when the Dirty LED is flashing continuously or sooner if conditions warrant.

## **⚠ CAUTION**

### **OPERATIONAL TEST HAZARD**

Failure to follow this caution may result in personnel and authority concern.

If the smoke detector is connected to a fire alarm system, first notify the proper authorities that the detector is undergoing maintenance then disable the relevant circuit to avoid generating a false alarm.

1. Disconnect power from the duct detector then remove the sensor's cover. (See Fig. 12.)
2. Using a vacuum cleaner, clean compressed air, or a soft bristle brush, remove loose dirt and debris from inside the sensor housing and cover.  
Use isopropyl alcohol and a lint-free cloth to remove dirt and other contaminants from the gasket on the sensor's cover.
3. Squeeze the retainer clips on both sides of the optic housing then lift the housing away from the printed circuit board.
4. Gently remove dirt and debris from around the optic plate and inside the optic housing.
5. Replace the optic housing and sensor cover.
6. Connect power to the duct detector then perform a sensor alarm test.

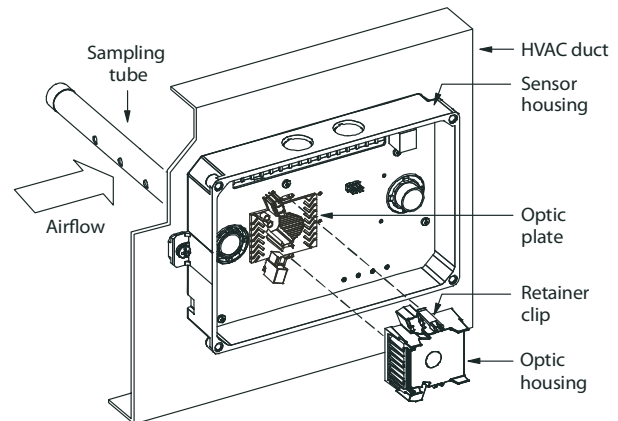

**Fig. 12 - Sensor Cleaning Diagram**

C07305

## TROUBLESHOOTING

### Controller's Trouble LED is On

1. Check the Trouble LED on each sensor connected to the controller. If a sensor's Trouble LED is on, determine the cause and make the necessary repairs.
2. Check the wiring between the sensor and the controller. If wiring is loose or missing, repair or replace as required.

### Controller's Trouble LED is Flashing

1. One or both of the sensors is 100% dirty.
2. Determine which Dirty LED is flashing then clean that sensor assembly as described in the detector cleaning section.

### Sensor's Trouble LED is On

1. Check the sensor's Dirty LED. If it is flashing, the sensor is dirty and must be cleaned.
2. Check the sensor's cover. If it is loose or missing, secure the cover to the sensor housing.
3. Replace sensor assembly.

### Sensor's Power LED is Off

1. Check the controller's Power LED. If it is off, determine why the controller does not have power and make the necessary repairs.
2. Check the wiring between the sensor and the controller. If wiring is loose or missing, repair or replace as required.

### Controller's Power LED is Off

1. Make sure the circuit supplying power to the controller is operational. If not, make sure JP2 and JP3 are set correctly on the controller before applying power.
2. Verify that power is applied to the controller's supply input terminals. If power is not present, replace or repair wiring as required.

### Remote Test/Reset Station's Trouble LED Does Not flash When Performing a Dirty Test, But the Controller's Trouble LED Does

1. Verify that the remote test/station is wired as shown in Fig. 8. Repair or replace loose or missing wiring.
2. Configure the sensor dirty test to activate the controller's supervision relay. See "Changing sensor dirty test operation."

### Sensor's Trouble LED is On, But the Controller's Trouble LED is OFF

Remove JP1 on the controller.

# GUIDE SPECIFICATIONS

## Controller Specifications

### A. Dimensions

- Controller only: 6.75 x 5.45 x 1.90 in.
- Controller and detector: 14.51 x 5.45 x 1.90 in.

### B. Operating Environment

- Temperature: -20° to 158°F (-29° to 70°C)
- Humidity: 10% to 93% RH, non-condensing

### C. Wire Size

- High voltage terminals: 12-22 AGW
- All others: 14-22 AGW

### D. Operating Voltages

- 20-29 VAC, 50/60 Hz
- 120 VAC, 50/60 Hz
- 220/240 VAC, 50/60 Hz

### E. Operating Current

- 20-29VDC: 175 mA
- 24 VAC: 500 mA at 50/60 Hz
- 120 VAC: 100 mA at 50 Hz  
75 mA at 60 Hz
- 220/240 VAC: 53 mA at 50 Hz  
40 mA at 60 Hz

### F. LED Indicators

- Red (Alarm)
- Yellow (Trouble)
- Green (Power)

### G. Relays

- Alarm initiation relay  
Quantity: 1  
Style: Normally open  
Ratings: 2.0A at 30 VDC (resistive)
- Auxiliary relay  
Quantity: 1  
Style: Form C  
Ratings: 10A at 30 VDC, 10A at 250 VAC
- Supervision (trouble) relay  
Quantity: 1  
Style: Form C  
Ratings: 2.0A at 30 VDC (resistive)

## Detector Specifications

### A. Sensor

- 8.70 x 5.45 x 1.90 in.

### B. Smoke Detection Method

- Photoelectric

### C. Operating Environment

- Same as controller

### D. Air Velocity (Min-Max)

- 100-4,000 ft/min

### E. Pressure Differential (Min-Max)

- 0.005-1.00 in.

### F. Sensitivity

- 0.67 to 2.48 %obscuration/ft
- Wire size: 14 to 22 AGW

### G. Reset Time

- 2 second maximum

### H. Power Up Time

- 8 second maximum

### I. Alarm Test Response Time

- 5 to 7 second

### J. LED Indicators

- Red (Alarm)
- Yellow (Trouble)
- Yellow (Dirty)
- Green (Power)

## Remote Keyed Attenuator and Test/Reset Station Specifications (KA-99ZT-003)

### A. Compatibility with electrical boxes

- North American 1-gang box
- Standard 4-in. square box, 1-1/2 in. deep, with 1-gang cover

### B. LED Indicators

- Red (Alarm)
- Yellow (Trouble)
- Green (Power)

### C. LED Type

- Clear lens

### D. Wire Size

- 14 to 22 AWG

### E. Resistance per Wire

- 10  $\Omega$ , max

### F. Operating Current

Same as controller specification

### G. Operating Voltages

- 24 Vdc, 24V at 50/60 Hz
- 120V at 50/60 Hz
- 220/240V at 50/60 Hz

### H. Compatible Detectors

- SuperDuct Four-Wire smoke detectors

### I. Operating Environment

- Temperature: 32° to 131°F (0° to 55°C)
- Humidity: 93% RH, non-condensing

### J. Storage Temperature

- -20° to 60°C (-4° to 140°F)

## UNIT SPECIFIC DATA

### Applicable Units:

48/50HE, 50HEQ003-006	581C, 551C, 549C024-060
48/50HJ, TM, TF004-014	581B, 551B036-150
50HJQ, TFO04-012	548F, 549F036-102
	580F, 558F036-151

### General

- For these units, the factory installed smoke detectors are typically installed as shown below. For horizontal return applications, the return air sample tube is moved in the field to extend across the horizontal opening.
- For applications with a factory installed economizer, the economizer is modified to incorporate the return air sample tube. For field installed economizers, the installer may desire to modify the economizer also; however, the factory modification does not need to be replicated.
- Factory provided detectors are wired such that if the unit is shut down on any other alarm (such as high head pressure) the detectors will still have power and can still provide a unit trip function.
- On units with PremierLink™ and Humidi-MiZer™ Adaptive Dehumidification System, it is recommended that the installing contractor route the two pink DEHUM wires through one of the smoke controller N.C. auxiliary relays.

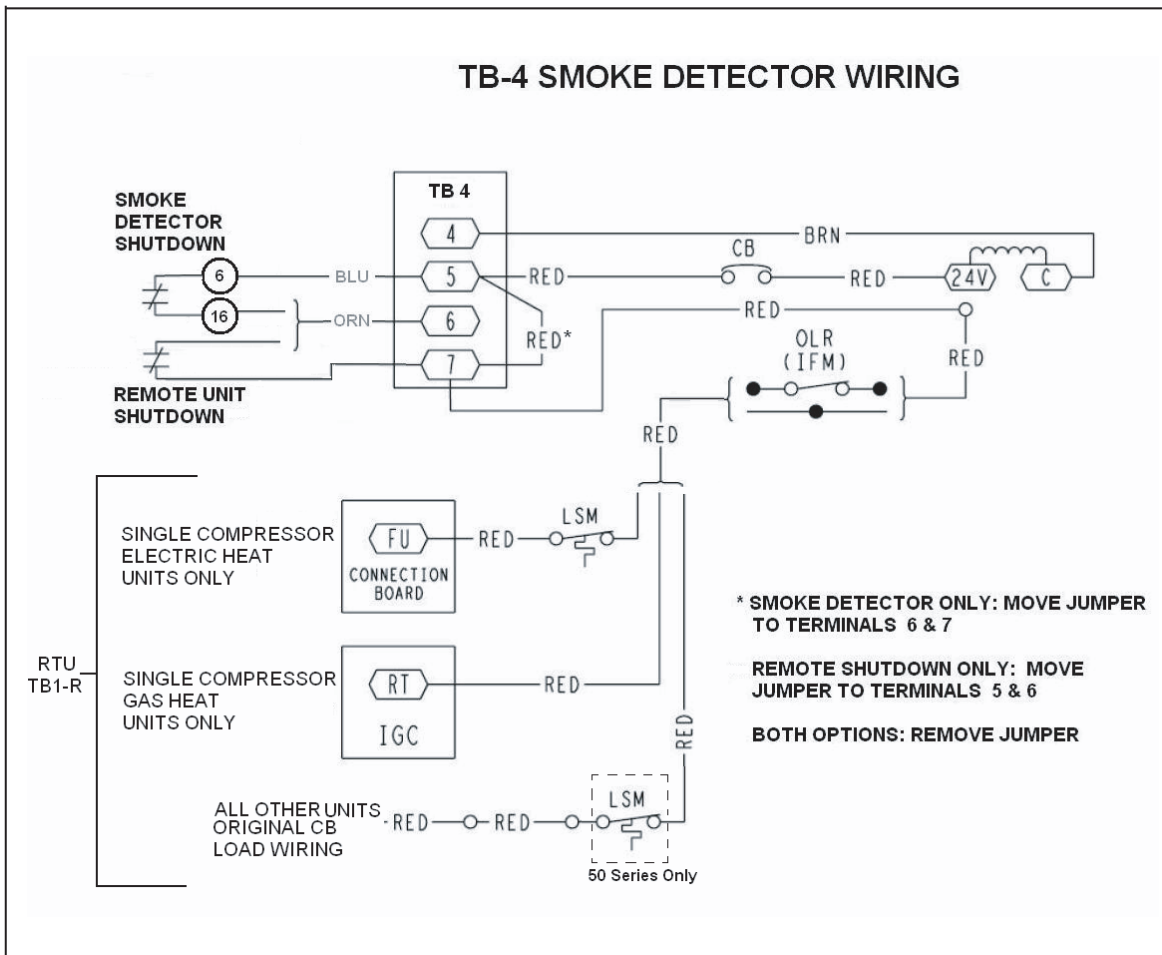
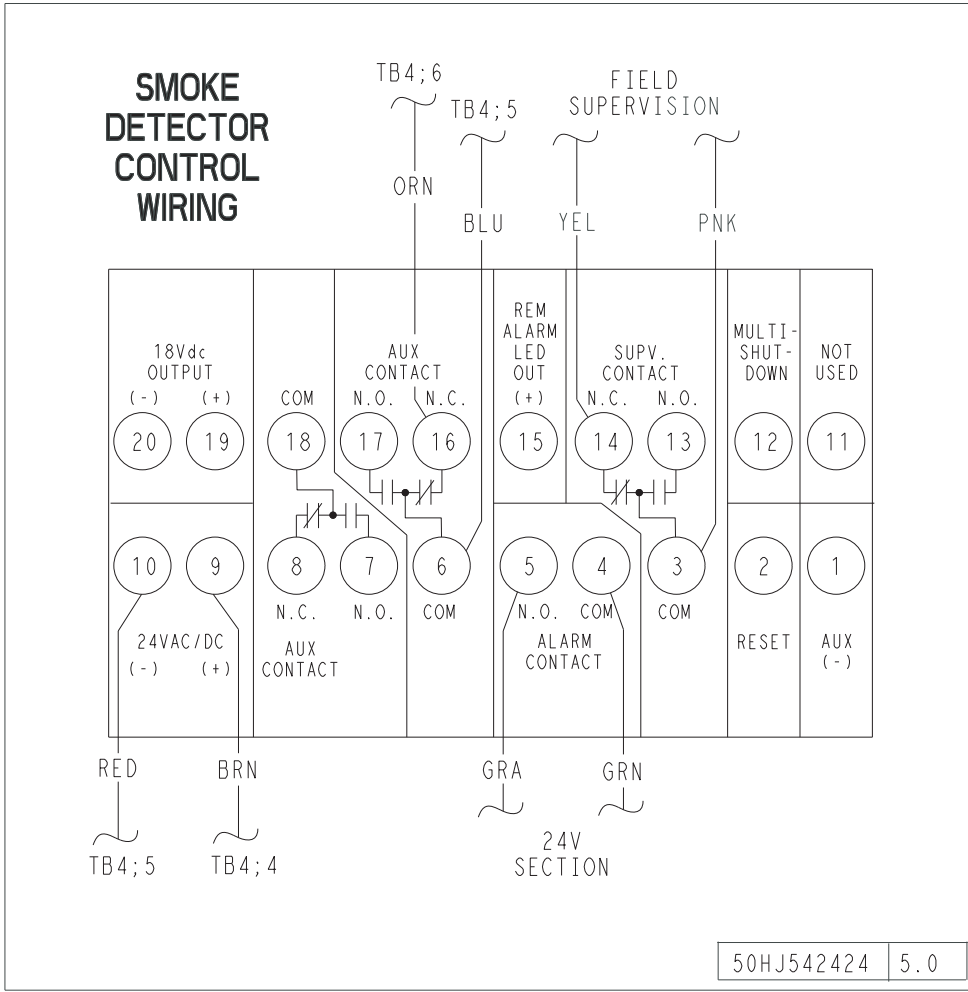

Fig. 13 - Typical TB-4 Wiring Diagram

C07413



**Fig. 14 - Smoke Detector Wiring Diagram**  
 (To be used in conjunction with rooftop unit wiring diagram)

C07304

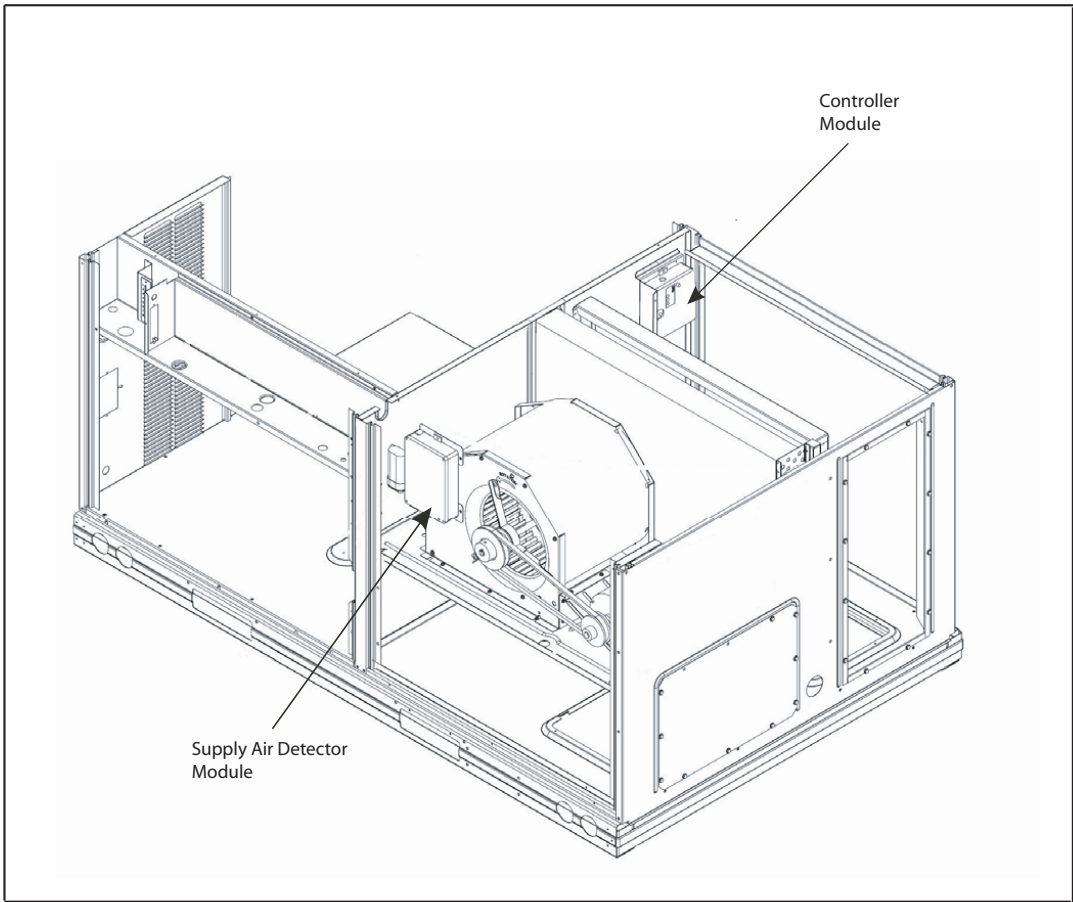

**Fig. 15 - Typical Supply Air Return Air Detector Location, 2-12.5 Ton Units (2-6 Ton Unit Shown)**

C07306

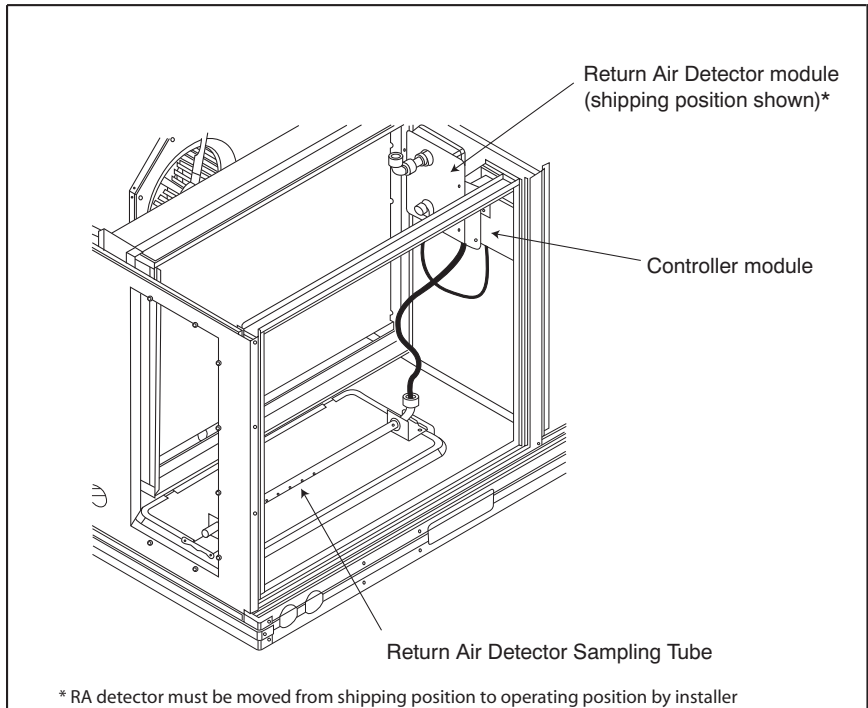

**Fig. 16 - Typical Return Air Detector Location, 2-12.5 Ton Units**

C07307

## Applicable Units:

48/50HJ015-017  
48/50TM, TJ016-028  
50HJQ014-016

581A, 551A155-180  
580F, 579F, 559F180-300  
542J150-180

## General

For these units, the factory installed smoke detectors are typically installed as shown below. For horizontal return applications, the return air sample tube is moved in the field to extend across the horizontal opening.

For applications with a factory installed economizer, the economizer is modified to incorporate the return air sample tube. For field installed economizers, the installer may desire to modify the economizer also, however, the factory modification does not need to be replicated.

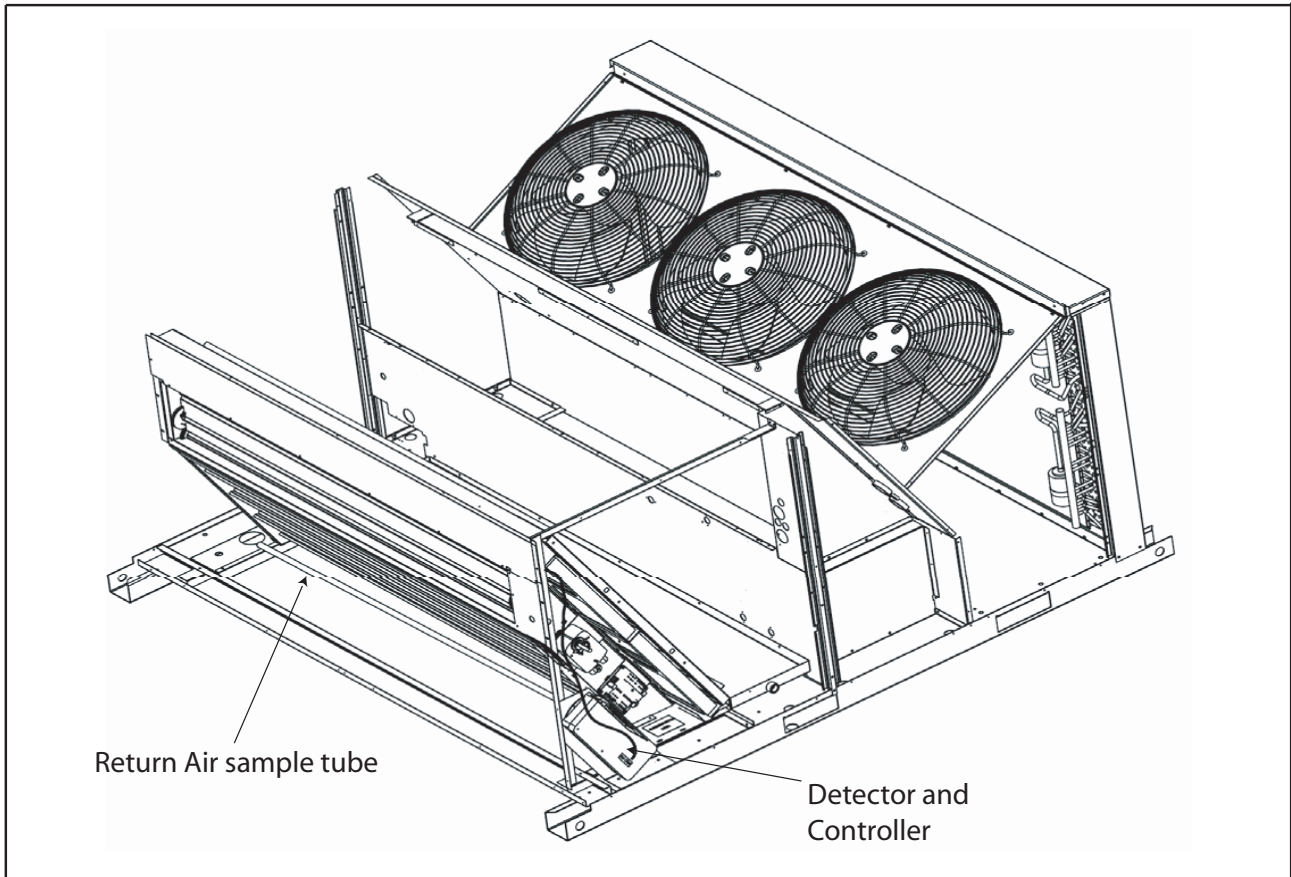

Fig. 17 - Typical Return Air Detector Location

C07414

### Applicable Units:

48/50HJ020-028                      581A, 551A210-300  
48/50HG014-028  
48/50PG020-028

### General

For these units, the following accessory installation kits are available for field installed smoke detectors: CRSMKDET001D00, CRSMKSUP001B00, CRSMKSEN001A00. See these kits as applicable for additional information.

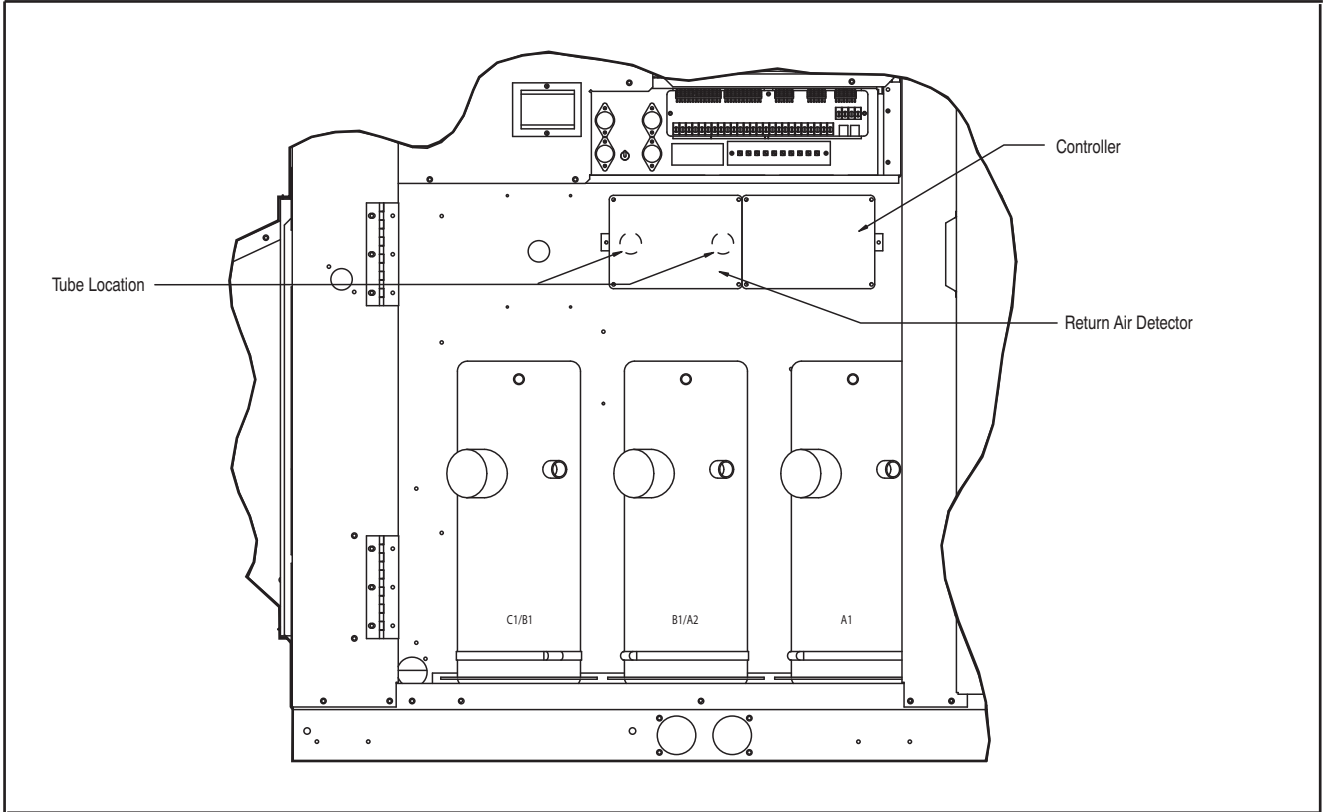

**HKRNKA**

**Fig. 18 - Return Air Detector Location**

C07415

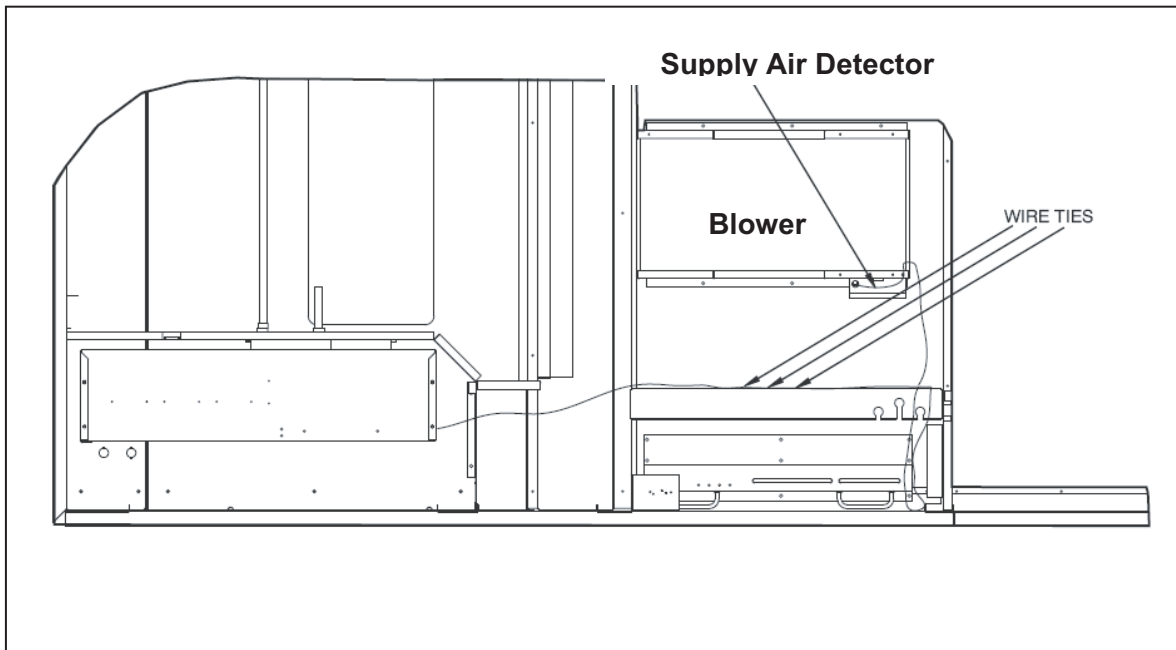

**Fig. 19 - Supply Air Detector Location (Top View of Unit)**

C07416

**Applicable Units:**

48/50PG03-16

**General**

For these units, the factory installed smoke detectors are typically installed as shown below. For horizontal return applications, the return air sample tube is moved in the field to extend across the horizontal opening.

For applications with a factory installed economizer, the economizer is modified to incorporate the return air sample tube. For field installed economizers, the installer may desire to modify the economizer also, however, the factory modification does not need to be replicated.

HKRNIKA

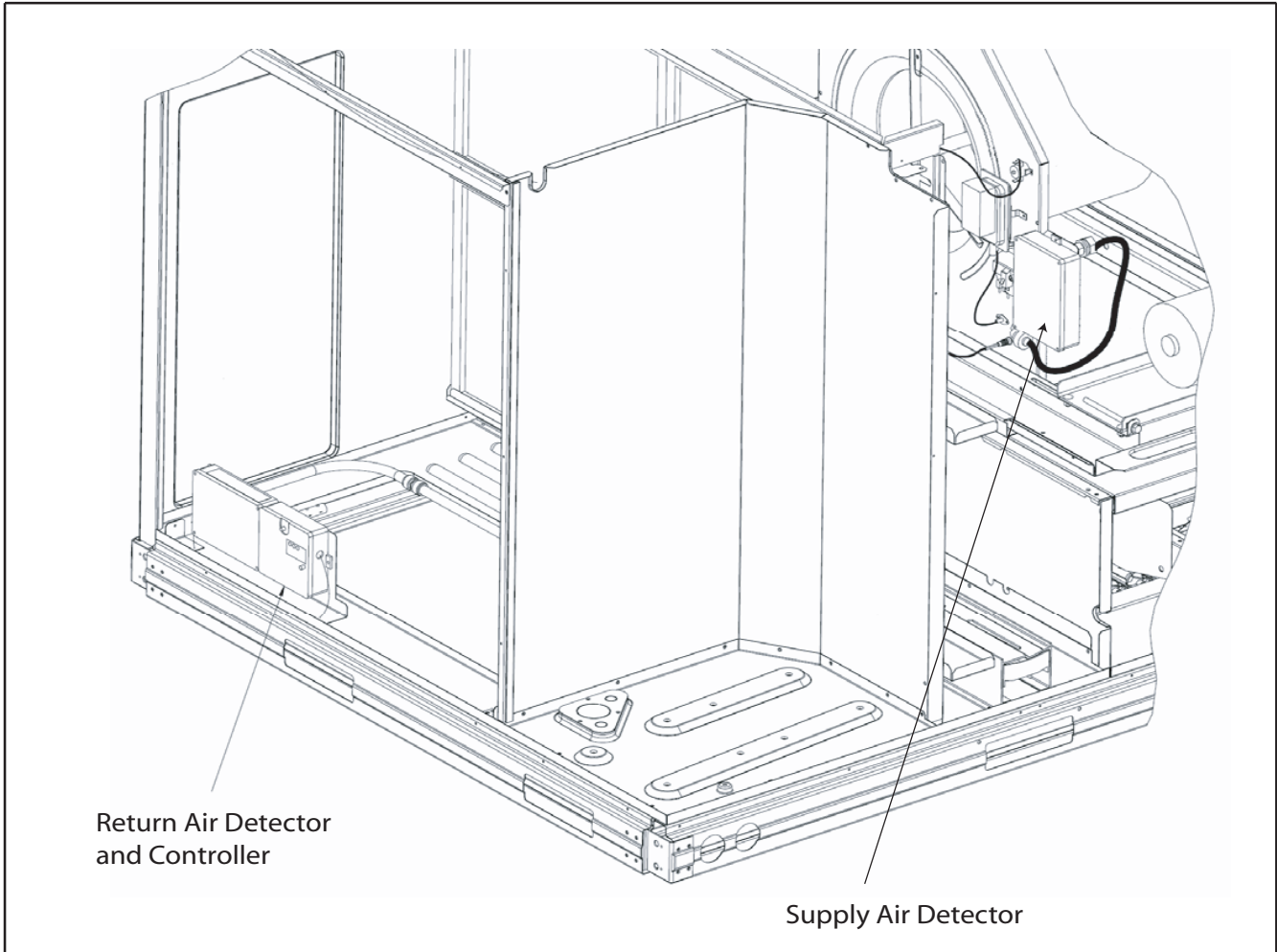

**Fig. 20 - Typical 48/50PG 2-15 Ton Detector Locations**

C07417



