

Installation Instructions

IMPORTANT: Read these instructions completely before attempting to install the accessory roofcurb adapter.

PACKAGE USAGE

WHEN REPLACING PAST CARRIER MODEL*	USE ADAPTER CURB	WHEN REPLACING WITH NEW CARRIER MODEL
48/50TJ016-028	CRADCURB004A00	48/50TC17-28
48/50TM016-024		
48/50HJ015-017		
48/50DP012-020		
48/50DR012-016		
50PQ012-016		
48/50DR012-016		

* Using curb similar to: CRRFCURB010A00
CRRFCURB011A00

WHEN REPLACING PAST CARRIER MODEL*	USE ADAPTER CURB	WHEN REPLACING WITH NEW CARRIER MODEL
48/50TM028	CRADCURB005A00	48/50TC28

* Using curb similar to: CRRFCURB025A00

SAFETY CONSIDERATIONS

Installation and servicing of air-conditioning equipment can be hazardous due to system pressure and electrical components. Only trained and qualified service personnel should install, repair, or service air-conditioning equipment.

Untrained personnel can perform the basic maintenance functions. All other operations should be performed by trained service personnel. When working on air-conditioning equipment, observe precautions in the literature, tags and labels attached to the unit, and other safety precautions that may apply.

Follow all safety codes. Wear safety glasses and work gloves.

Recognize safety information. This is the safety-alert symbol . When you see this symbol on the unit and in instructions or manuals, be alert to the potential for personal injury.

Understand the signal words DANGER, WARNING, and CAUTION. These words are used with the safety-alert symbol. DANGER identifies the most serious hazards which **will** result in severe personal injury or death. WARNING signifies a hazard which **could** result in personal injury or death. CAUTION is used to identify unsafe practices which **may** result in minor personal injury or product and property damage. NOTE is used to highlight suggestions which **will** result in enhanced installation, reliability, or operation.

GENERAL

IMPORTANT: Before ordering curb adapter, contractor must confirm that dimensions of existing curb on job site matches dimensions of existing curb in Fig. 2 and 3.

IMPORTANT: Before new HVAC unit is set in place, inspect structural stability of existing curb and building's roof load capability. Reinforce, if required.

These curb adapters are designed to allow an older/existing HVAC unit to be replaced with a newer model while using the existing unit's roofcurb, and eliminating the need to and the liability associated with re-roofing required when a new roofcurb is set. This is accomplished by setting a curb adapter on top of the existing curb which transitions to the new unit's footprint and support requirements.

The curb adapter includes internal duct transitions to minimize field duct modifications and static pressure loss. (See Table 1.)

Features

- Fully assembled curb adapter.
- Includes internal transitions.
- Internally insulated with 1"-1.5 lbs insulation. Gasketing package provided.

	A	Weight
CRADCURB004A00	121-5/8"	385 lbs. (175 kg)
CRADCURB005A00	135-5/8"	425 lbs. (193 kg)

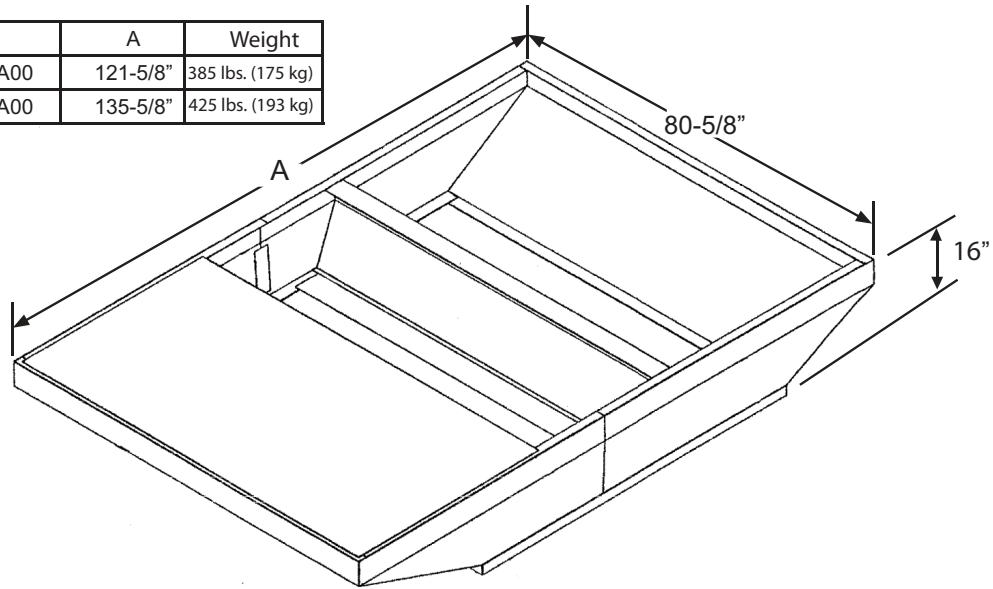

Fig. 1 - Roof Curb Adapter Dimensions and Weight

C09367

Table 1 – Air Side Pressure Drop

CFM	PRESSURE DROP (in.wg)
4500	.38
5000	.38
5500	.39
6000	.39
6500	.40
7000	.40
7500	.41
8000	.41
8500	.42
9000	.43
9500	.44
10000	.45
10500	.46
11000	.47
11500	.48
12000	.49
12500	.50

A. These curb adapters are designed to fit specific existing roofcurb dimensions. The anticipated existing curb is dimensioned in Fig. 2 and 3. In the event that your specific job has an existing curb that does not meet these dimensions, this curb adapter will not fit properly.

Before ordering or installing the curb, verify that the existing curb dimensions match those in Fig. 2 and 3.

B. The installing contractor must inspect the existing curb and roof structure to determine if it is capable of supporting the new curb adapter and HVAC unit.

NOTE: The new HVAC unit is considerably heavier than the existing unit. Check unit literature for exact weight of new unit. Field reinforcement of the existing curb or roof structure may be required.

INSTALLATION CONSIDERATIONS

⚠ CAUTION

CUT HAZARD

Failure to follow this caution may result in personal injury.

When removing access panels or performing maintenance functions inside your unit, be aware of sharp sheet metal parts and screws. Although special care is taken to reduce sharp edges to a minimum, be extremely careful when handling parts or reaching into the unit.

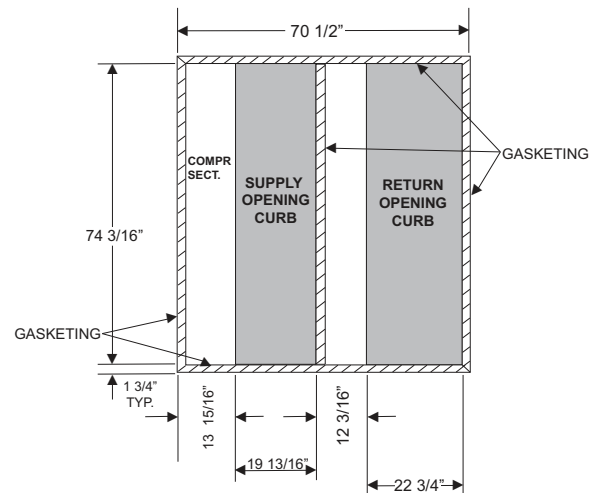

Fig. 2 - Plan View of Existing Curb Used with CRADCURB004A00

C09336

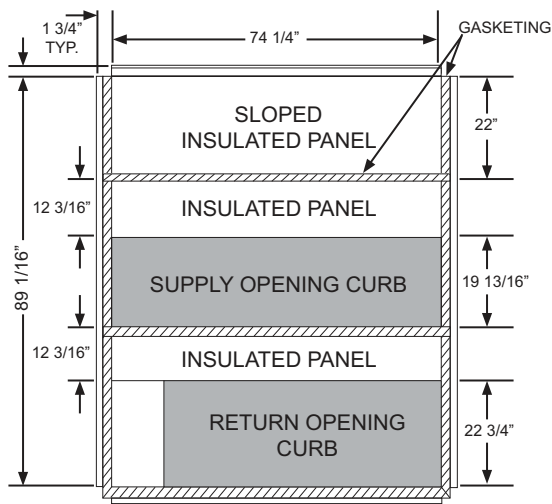

Fig. 3 - Plan View of Existing Curb Used with CRADCURB005A00

C09337

- C. The new unit with curb adapter will overhang the existing roof curb. Review overhang dimensions in Fig. 6 to determine if this is acceptable for your specific job.
- D. **Curb adapters will increase the systems external static pressure and must be included when calculating unit airflow requirements.**
- E. Some existing installations have the duct attached to the base of the unit. Inspect before lifting unit and disconnect duct if applicable.
- F. Follow all local and state codes when installing this product.

INSTALLATION

⚠ WARNING

ELECTRICAL SHOCK HAZARD

Failure to follow this warning could result in personal injury and/or death.

Disconnect power supply and install lockout tag before attempting to install the accessory.

1. Remove electric, gas and duct connections to existing HVAC unit. Some existing installations have the duct attached to the base of the unit. Inspect before lifting unit and disconnect duct if applicable.
2. Lift existing unit from roof, exposing the existing roof curb.
3. Measure the existing curb and make sure it matches the dimensions in Fig. 2 and 3. If the dimensions do not match, the curb adapter will not fit the curb properly.
4. Inspect the structural stability of the existing curb and roof structure to make sure that they are capable of supporting the curb adapter and the new unit.

NOTE: The new unit will weigh significantly more than the existing unit. See unit literature for exact weights. Reinforce the existing curb and roof structure as required.

5. Remove any gasketing on the top perimeter of the existing curb. Install new (provided) gasketing to the top perimeter of the existing curb, and around duct openings. (See Fig. 2 and 3.)
6. Lift curb adapter and set on top of the existing curb, making sure that the duct connections are oriented correctly, with the return of the curb adapter aligning with the existing return duct.
7. Secure the side flanges of the curb adapter to the turn down flange on the existing curb. Screws should be around the full perimeter and should be approximately 18" apart. (See Fig. 4.)

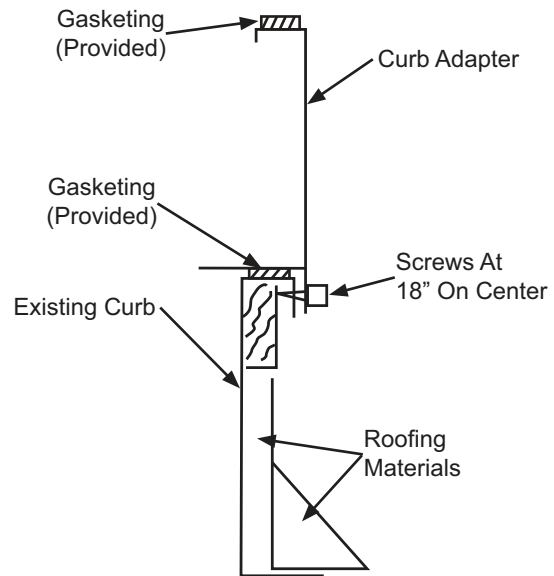

Fig. 4 - Securing Curb Adapter to Existing Curb

C09368

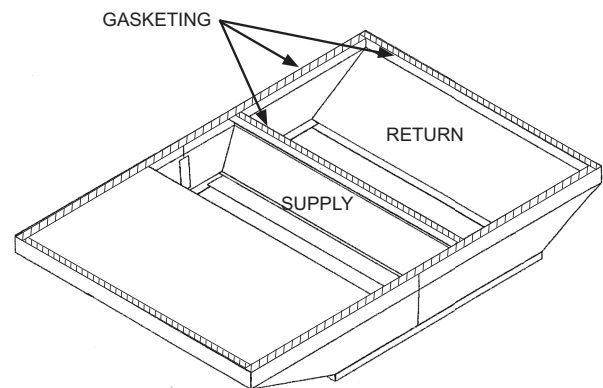
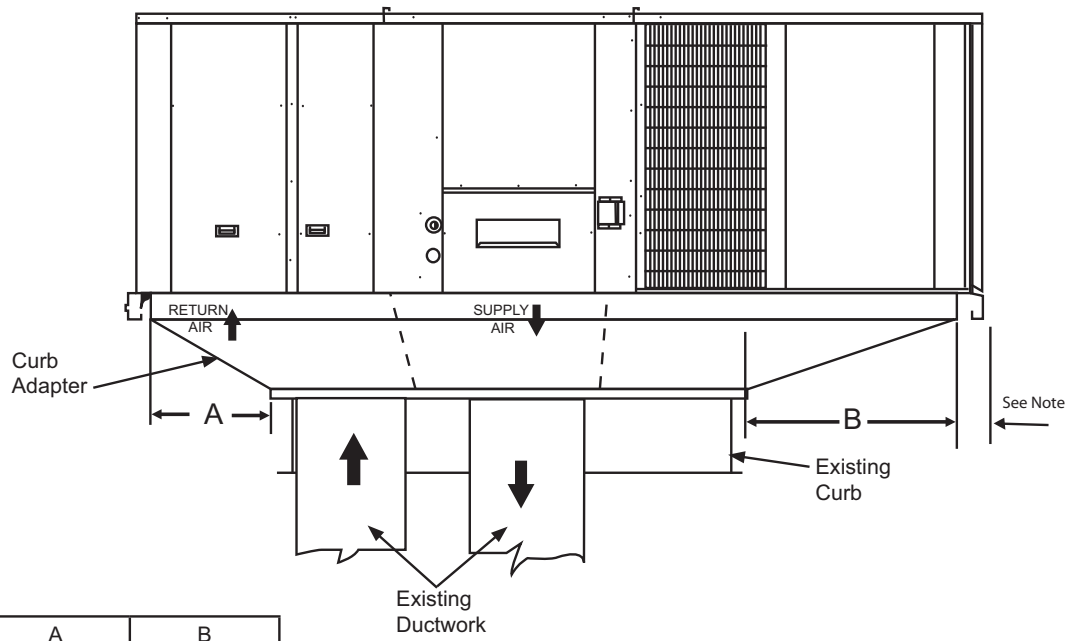

Fig. 5 - Gasket Location on Curb Adapter

C09369

8. Install the provided gasket around the top perimeter and around duct connections on top of curb adapter. (See Fig. 5.)
9. Carefully lift the new unit and set in place on the curb adapter making sure that duct openings are oriented correctly. Follow unit rigging instructions and labels.
10. Make the necessary utility connections to the new unit, according to the unit instructions. Install any other unit accessories and follow unit start-up instructions.



	A	B
CRADCURB004A00	20 3/4"	30 3/8"
CRADCURB005A00	16 3/4"	26 3/4"

NOTE: When the CRADCURB004A00 curb adapter is used with the 24/28 units, the unit will overhang the curb adapter by an additional 18". In the event the overhang is not acceptable, contact MicroMetl for additional curb adapter options.

Fig. 6 - Offset Dimensions

C09370