

# Installation Instructions

## TABLE OF CONTENTS

PACKAGE CONTENTS - HH57AC078 ..... 1  
 PACKAGE CONTENTS - CRENTDIF004A00 ..... 1  
 SAFETY CONSIDERATIONS ..... 2  
 GENERAL ..... 2  
     Outdoor Enthalpy Changeover Control ..... 2  
     Differential Enthalpy Control ..... 2  
 INSTALLATION ..... 3  
     Single Outdoor Air Enthalpy Sensor ..... 3-6  
     Differential Enthalpy Sensor ..... 7-10  
 CONFIGURATION ..... 11  
     Outdoor Enthalpy Changeover Control ..... 11  
     Differential Enthalpy Control ..... 11

**IMPORTANT:** Read these instructions completely before attempting to install the accessory enthalpy sensor.

### PACKAGE CONTENTS - HH57AC078

QTY	CONTENTS
1	Enthalpy Sensor

### CRENTDIF004A00

QTY	CONTENTS
1	Enthalpy Sensor
2	6-20, 3/4 in. Sheet Metal Screw
1	Grommet
1	Black Wire
1	Red Wire

The HH57AC078 and CRENTDIF004A00 enthalpy sensors are used with the Economi\$er IV (part numbers CRECOMZR008C00, 020A02, 021A03, 024A02, 025A02, 038A00, 039A00, 040A00, 041A00, 042A00, 046A00, 047A00, 050A00, 051A00, 056A00, 057A00, 062A00, 064A00) and are used on the following units:

UNIT	SIZE	UNIT	SIZE
48HE	003-006	542J	150-180
50HE	003-006	548F	036-120
50HEQ	003-006	549B	036-120
48HJ	004-028	549C	024-060
50HJ	004-028	551A	155-300
50HJQ	004-016	551B	036-150
48PD	05-06	551C	024-060
50PD	05-06	558F	036-300
48PG	03-28	558J	04-16
50PG	03-28	559F	180-300
48PM	20-28	579F	180-300
50PM	20-28	580F	036-300
48TC	04-16	580J	04-16
50TC	04-16	581A	155-300
48TF	004-014	581B	036-150
50TFF	004-014	581C	024-060
50TCQ	04-14	548J	04-14
48HC	04-14	581J	04-14
50HC	04-14	551J	04-14
50HCQ	04-12	549J	04-12
50TFQ	004-012		
48TJ	016-028		
50TJ	016-028		
48TM	004-028		
50TM	004-028		

The accessory enthalpy sensor can be used on all rooftop units with a factory-installed or accessory Economi\$er IV.

**Table 1 – Economizer IV Sensor Usage**

APPLICATION	Economizer IV WITH OUTDOOR AIR DRY BULB SENSOR		
	Accessories Required		
Outdoor Air Dry Bulb	None. The outdoor air dry bulb sensor is factory installed.		
Differential Dry Bulb	CRTEMPSN002A00*		
Single Enthalpy	HH57AC078		
Differential Enthalpy	HH57AC078 and CRENTDIF004A00*		
CO <sub>2</sub> for DCV Control using a Wall–Mounted CO <sub>2</sub> Sensor	33ZCSENCO2 or CGCDXSEN004A00†		
CO <sub>2</sub> for DCV Control using a Duct–Mounted CO <sub>2</sub> Sensor	33ZCSENCO2 or CGCDXSEN004A00† and 33ZCASPCO2 or CGCDXASP001A00**	OR	CRCBDIOX005A00††

\* CRENTDIF004A00 and CRTEMPSN002A00 accessories are used on many different base units. As such, these kits may contain parts that will not be needed for installation.

† 33ZCSENCO2 and CGCDXSEN004A00 are accessory CO<sub>2</sub> sensors.

\*\* 33ZCASPCO2 and CGCDXASP001A00 are accessory aspirator boxes required for duct–mounted applications.

†† CRCBDIOX005A00 is an accessory that contains both 33ZCSENCO2 and 33ZCASPCO2 accessories.


NOTE: Some 48/50PD05–06, PG03–28, PM20–28, 48/50TC04–16, 50TCQ04–14, 48/50HC04–14, 50HCQ04–12, 558J/580J04–16, 548J04–14, 581/551J04–14, and 549J04–12 units may have factory–installed enthalpy sensor.

## SAFETY CONSIDERATIONS


Installation and servicing of air-conditioning equipment can be hazardous due to system pressure and electrical components. Only trained and qualified service personnel should install, repair, or service air-conditioning equipment.

Untrained personnel can perform the basic maintenance functions. All other operations should be performed by trained service personnel. When working on air-conditioning equipment, observe precautions in the literature, tags and labels attached to the unit, and other safety precautions that may apply.

Follow all safety codes. Wear safety glasses and work gloves. Use quenching cloth for unbrazing operations. Have fire extinguishers available for all brazing operations.

Recognize safety information. This is the safety-alert symbol . When you see this symbol on the unit and in instructions or manuals, be alert to the potential for personal injury.

Understand the signal words DANGER, WARNING, and CAUTION. These words are used with the safety-alert symbol. DANGER identifies the most serious hazards which **will** result in severe personal injury or death. WARNING signifies a hazard which **could** result in personal injury or death. CAUTION is used to identify unsafe practices which **may** result in minor personal injury or product and property damage. NOTE is used to highlight suggestions which **will** result in enhanced installation, reliability, or operation.

** WARNING**

**ELECTRICAL SHOCK HAZARD**

Failure to follow this warning could result in personal injury and/or death.

Disconnect power supply and install lockout tag before attempting to install accessory.

## GENERAL

The 48/50PD, PG, PM, TC, TCQ, HC, HCQ, 558J, 580J, 548J, 581J, 551J and 549J units have a choice of dry-bulb or enthalpy sensor with the factory-installed Economizer IV. All other units come with the dry-bulb sensor as standard with the factory-installed Economizer IV.

For units equipped with dry-bulb enthalpy sensors, accessory HH57AC078 can be used to reconfigure the Economizer IV for outdoor enthalpy changeover control.

Accessories HH57AC078 and CRENTDIF004A00 can both be added for differential enthalpy control and the sensor is used for outdoor temperature control. (See Table 1.)

### Outdoor Enthalpy Changeover Control

For enthalpy control, accessory enthalpy sensor (part number HH57AC078) is required. When the outdoor air enthalpy rises above the outdoor enthalpy changeover set point, the outdoor-air damper moves to its minimum position.

### Differential Enthalpy Control

For differential enthalpy control, the Economizer IV controller uses two enthalpy sensors (HH57AC078 and CRENTDIF004A00), one in the outside air and one in the return airstream. The Economizer IV controller compares the outdoor air enthalpy to the return air enthalpy to determine Economizer IV use. The controller selects the lower enthalpy air (return or outdoor) for cooling. For example, when the outdoor air has a lower enthalpy than the return air and is below the set point, the Economizer IV opens to bring in outdoor air for free cooling.

## INSTALLATION

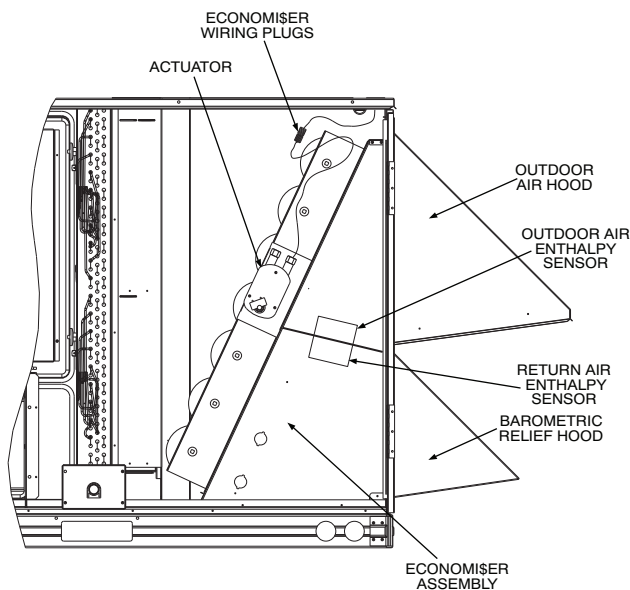
**NOTE:** The 48/50PD, PG, PM, TC, TCQ, HC, HCQ, 558J, 580J, 548J, 581J, 551J and 549J units have a choice of dry-bulb or enthalpy sensor with the factory-installed Economi\$er IV.

### Single Outdoor Air Enthalpy Sensor Installation for 48/50PG03-16 and 48/50PD05-06 Units

If installing the enthalpy sensor on an accessory Economi\$er IV, it is easier to install the enthalpy sensor before installing the Economi\$er IV. If installing the sensor on a factory-installed Economi\$er IV, it is easier to install the enthalpy sensor before installing the Economi\$er IV hoods.

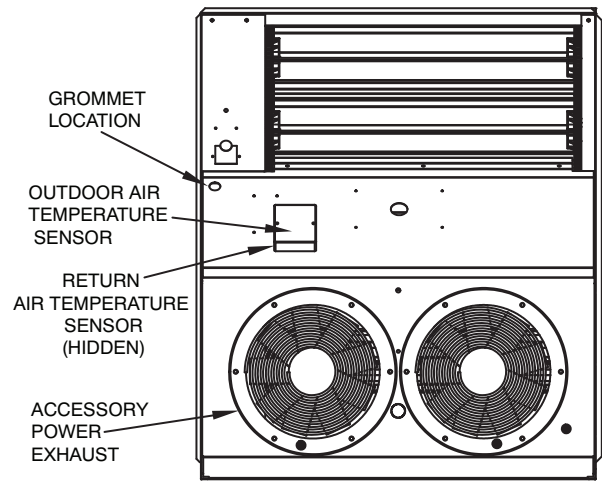
**NOTE:** For horizontal applications, it is easiest to install the enthalpy sensor before making duct connections.

1. Turn off power to unit and install Lockout Tag.
2. Remove the screws securing the Economi\$er IV hood to the unit. Save the screws for use in Step 7. On units with a factory-installed Economi\$er IV, the panel will be hinged and should not be removed from the unit. Open the hinged panel and secure it.
3. Remove the pre-existing outdoor enthalpy sensor and save the screws for Step 4. Disconnect the pink and yellow wires from the enthalpy sensor and let them hang. The wires will be used to connect to the enthalpy sensor.



**Fig. 1 - Side View of Vertical Economi\$er — 48/50PD05-06 and 48/50PG03-16 Units**

C07407



**Facing Economizer**

C101047

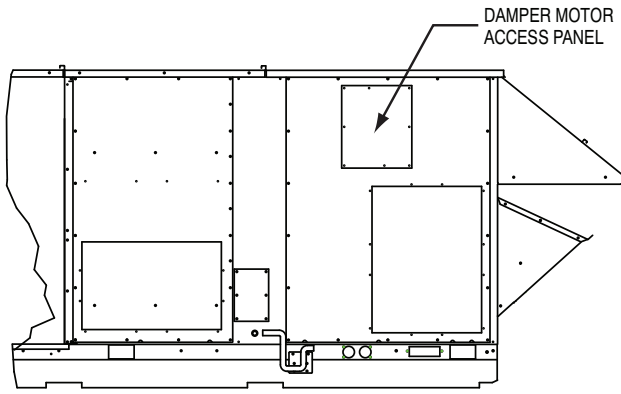
**Fig. 2 - Sensor Locations — 48/50PD05-06 and 48/50PG03-16 Units**

4. Mount the enthalpy sensor to the top (outdoor air side) of the Economi\$er IV frame, using the two sheet metal screws (no. 8) from Step 3. There are two screw holes in the Economi\$er IV frame for ease of installation.
5. Locate the pink and yellow wires coming from the Economi\$er IV controller terminals “SO+” (pink) and “SO” (yellow). (See Fig. 4.) Connect the wires to the enthalpy sensor. Connect the yellow wire to the “S” terminal and the pink wire to the “+” terminal on the enthalpy sensor. (See Fig. 5.)
6. If the accessory differential enthalpy sensor is also being installed, skip to the Differential Enthalpy Sensor installation instructions on page 7.
7. Replace (or close if hinged panel) the Economi\$er IV panel. Secure the panel using the screws saved from Step 2.
8. Restore power to the unit and configure the Economi\$er IV controller per the Configuration section in this manual.

HH57AC078, CRENTDIF004A00

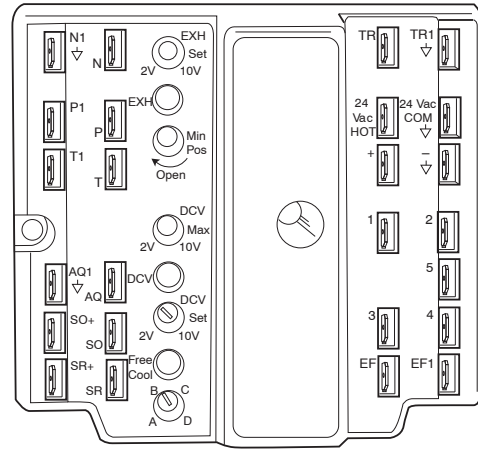
# Single Outdoor Air Enthalpy Sensor Installation for 48/50PG20-28, 48/50PM20-28, 48/50HJ020-028 and 551A/581A210-300 Units

1. Turn off power to unit and install Lockout Tag.
2. Remove the damper motor access panel at the back of the unit. (See Fig. 3.) Save screws for use in Step 7.

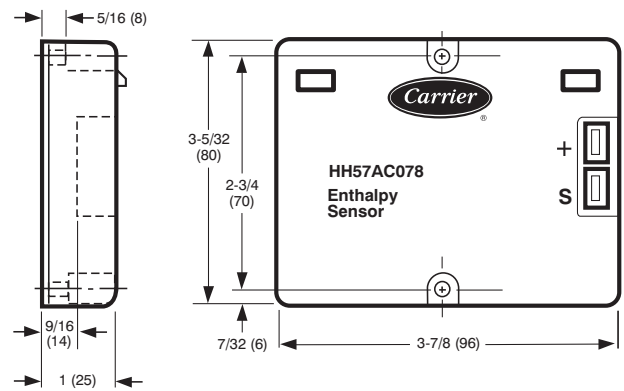


**Fig. 3 - Back View — Damper Motor Access Panel Location**

3. Remove the pre-existing outdoor air enthalpy sensor and save the screws for Step 4. Disconnect the pink and yellow wires from the enthalpy sensor and let them hang. The wires will be used to connect to the enthalpy sensor.
4. Mount the enthalpy sensor in the predrilled holes on the Economi\$er frame (where the enthalpy sensor was removed in Step 3). (See Fig. 6.) Use the screws removed in Step 3.
5. Locate the pink and yellow wires coming from the Economi\$er IV controller terminals “SO+ ” (pink) and “SO” (yellow). (See Fig. 4.) Connect the wires to the enthalpy sensor. Connect the yellow wire to the “S” terminal and the pink wire to the “+” terminal on the enthalpy sensor. (See Fig. 5.)
6. If the accessory differential enthalpy sensor is also being installed, skip to the Differential Enthalpy Sensor installation instructions on page 8.
7. Replace the damper motor access panel. Secure the panel using the screws saved from Step 2.
8. Restore power to the unit and configure the Economi\$er IV controller per the Configuration section in this manual.

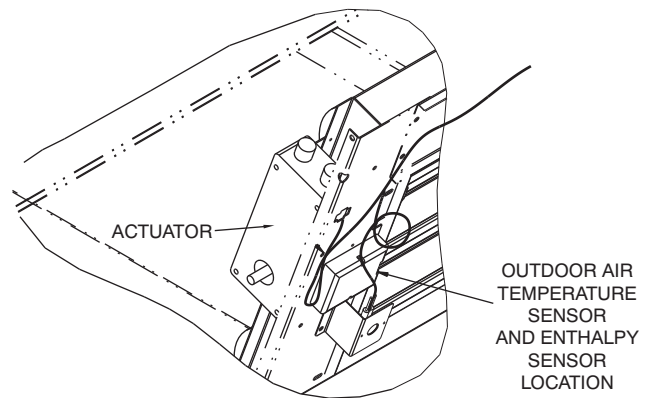


**Fig. 4 - Economi\$er IV Controller (Honeywell W7212)**



**Fig. 5 - Enthalpy Sensor Specifications**

**NOTE:** Dimensions are in inches. Dimensions in ( ) are in millimeters.



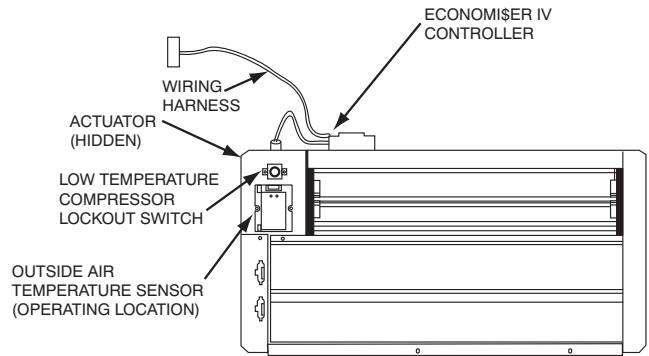
**Fig. 6 - Outdoor Air Sensor Location —  
48/50PG20-28, 48/50PM20-28, 48/50HJ020-028,  
and 551A/581A210-300 Units**

HH57AC078, CRENTDIF004A00

**Single Outdoor Air Enthalpy Sensor  
Installation for 48/50TC04-16, 48/50HC04-14,  
50TCQ04-14, 50HCQ04-12  
48/50HE,TF,TM003-014, 48/50HJ004-014,  
50HEQ,TFQ003-012, 50HJQ004-012,  
558J/580J04-16, 548J04-14, 581/551J04-14,  
549J04-12, 548F/549B,C036-120,  
551B,C/558F/580F/581B,C024-151 Units**

**NOTE:** This section assumes you are starting with an Economi\$er IV installed in the rooftop and equipped with a dry bulb temperature sensor (p/n HH57AC074). If your Economi\$er is already equipped with single enthalpy sensor (p/n HH57AC078), **STOP**. You do not need to continue with this section.

1. Turn off power to unit and install Lockout Tag.
2. Depending on the type of panels the unit is equipped with:
  - a. Units with standard panels —  
Remove the Economi\$er hood from the base unit and save the screws for Step 9a.
  - b. For units with factory-installed hinged panels —  
Open the hinged panel and secure it. Since the panel is hinged, do not remove it from the unit.
3. Disconnect the black and red wires from the pre-existing temperature sensor (p/n HH57AC074) and let them hang. Remove the air temperature sensor and save screws (no. 8) for use in Step 4. The wires will be used later to connect to the enthalpy sensor.
4. Use the 2 sheet metal screws (no. 8) from Step 3 to mount the enthalpy sensor on the front left of the Economi\$er frame. (See Fig. 7.) Use the 2 screw holes in the Economi\$er frame.



C07367

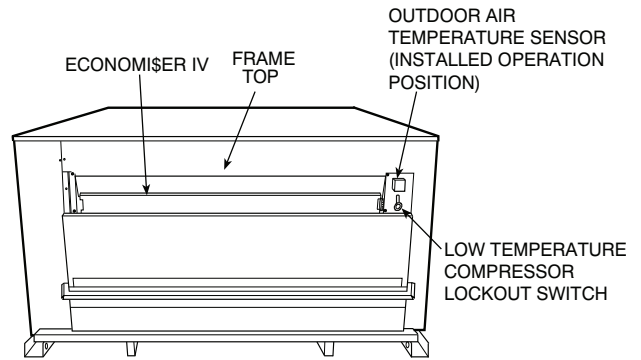
**Fig. 7 - Economi\$er IV Component Locations —  
48/50TC04-16, 48/50HC04-14, 50TCQ04-14,  
50HCQ04-14, 48/50HE,TF,TM004-014,  
48/50HJ004-014, 50HEQ,TFQ003-012,  
50HJQ004-012, 558J/580J04-16, 548J04-14,  
581/551J04-14, 549J04-12, 548F/549B,C036-120,  
551B/558B/558J/580F/580J/581B036-150 Units**

5. Ensure the black and red wires are connected on the Economi\$er IV controller correctly. The red wire should be connected to the “SO” terminal and the black wire to the “SO+” terminal. (See Fig. 4.) If they are not connected this way, make the connections as described. If you are using CRENTDIF004A00, the kit contains an extra red and black wire.
6. Pick up the black and red wires left hanging from Step 3 and connect them to the enthalpy sensor. Connect the red wire to the sensor’s “S” terminal and the black wire to the sensor’s “+” terminal. See Fig. 5 for details.
7. If installation of the accessory differential enthalpy sensor is also planned, skip to Step 3 of the Differential Enthalpy Sensor installation section of this instruction.
8. Restore power to the unit and configure the Economi\$er IV controller per the Configuration section of this manual.
9. Depending on the type of panels the unit is equipped with:
  - a. Units with standard panels —  
Re-install the Economi\$er hood. Secure the panel using the screws saved from Step 1a.
  - b. Units with factory-installed hinged panels —  
Close the hinged panel and latch it.

**HH57AC078, CRENTDIF004A00**

**Single Outdoor Air Enthalpy Sensor  
Installation for 48/50HJ015-017,  
50HJQ014-016, 48/50TJ, TM016-028,  
542J150-180, 551A/581A155-180,  
558F/559F/579F/580F180-300 Units**

**NOTE:** This section assumes you are starting with an Economi\$er IV installed in the rooftop and equipped with a dry bulb temperature sensor (p/n HH57AC074). If your Economi\$er is already equipped with a single enthalpy sensor (p/n HH57AC078), **STOP**. You do not need to continue with this section.



C07412

**Fig. 8 - Economi\$er IV Component Locations —  
48/50HJ015-017, 50HJQ014-016, 48/50TJ,  
TM016-028, 542J150-180, 551A/581A155-180,  
558F/559F/579F/580F180-300 Units**

1. Turn off power to unit and install Lockout Tag.
2. Remove the Economi\$er hood from the base unit and save the screws for Step 9.
3. Depending on the type of panels the unit is equipped with:
  - a. Units with standard panels —  
Access the Economi\$er by removing the return-air filter access panel. Save the screws for Step 11a.
  - b. For units with factory-installed hinged panels —  
Access the Economi\$er IV controller by opening the hinged return-air filter access panel and securing it. Since the panel is hinged, do not remove it from the unit.
4. Disconnect the black and red wires from the pre-existing temperature sensor (p/n HH57AC074) and let them hang. Remove the air temperature sensor and save the screws (no. 8) for use in Step 5. The wires will be used later to connect to the enthalpy sensor.
5. Mount the enthalpy sensor to the front right of the Economi\$er frame, as shown in Fig. 8. Use the two sheet metal screws (no. 8) from Step 4 and screw into the holes in the Economi\$er frame.
6. Ensure the black and red wires are connected on the Economi\$er IV controller correctly. The red wire should be connected to the “SO” terminal and the black wire to the “SO+” terminal. If they are not connected this way, make the connections as described. If you are using CRENTDIF004A00, the kit contains an extra red and black wire.
7. Pick up the the black and red wires left hanging from Step 4 and connect them to the enthalpy sensor. Connect the red wire to the sensor’s “S” terminal and the black wire to the sensor’s “+” terminal. See Fig. 5 for details.
8. If installation of the accessory differential enthalpy sensor is also planned, skip to Step 3 of the Differential Enthalpy Sensor installation section of this instruction.
9. Re-install the Economi\$er hood using the screws from Step 2.
10. Restore power to the unit and configure the Economi\$er IV controller per the Configuration section of this manual.
11. Depending on the type of panels the unit is equipped with:
  - a. Units with standard panels —  
Re-install the return-air filter access panel using the screws from Step 3a.
  - b. For units with factory-installed hinged panels —  
Close the hinged panel and latch it.

HH57AC078, CRENTDIF004A00

## Differential Enthalpy Sensor

If installing the differential enthalpy sensor on an accessory Economi\$er, it is easier to install the differential enthalpy sensor before installing the Economi\$er. If installing the sensor on a factory-installed Economi\$er, it is easier to install the differential enthalpy sensor before installing the Economi\$er hoods.

A single enthalpy sensor (HH57AC078) must be installed in addition to the differential enthalpy sensor (CRENTDIF004A00) to achieve differential enthalpy Economi\$er control.

For horizontal applications, it is easiest to install the differential enthalpy sensor before making duct connections.

### Differential Enthalpy Sensor Installation Instructions for 48/50PD05-06 and 48/50PG03-16 Units

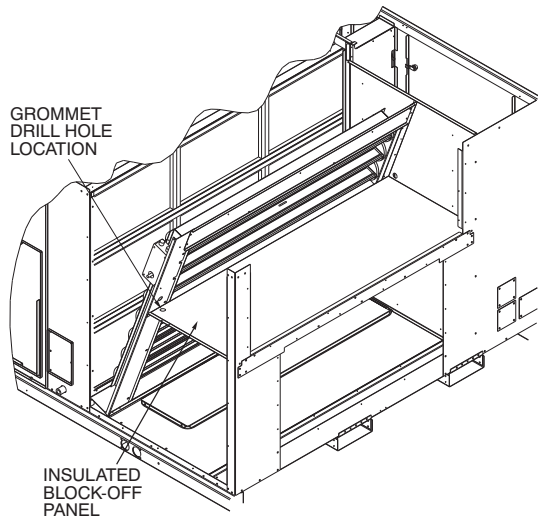
**NOTE:** All wiring for the sensors on 48/50PG and 48/50PM units is factory-provided. The red and black wires provided with the accessory are not used.

1. Turn off power to unit and install Lockout Tag.
2. Remove the Economi\$er hood from the base unit and save the screws for use in Step 9. On units with factory-installed Economi\$ers, the panel is hinged and should not be removed from the unit. Open the hinged panel and secure it.
3. Remove the plug button in the Economi\$er deck and install the grommet supplied with the kit into the hole. (See Fig. 2.)

4. If there is a pre-existing differential enthalpy sensor, remove the sensor. To remove the sensor, disconnect the blue and orange wires from the differential enthalpy sensor and let them hang. They are used later to connect the differential enthalpy sensor. Remove the differential enthalpy sensor and save the screws for use in Step 5.
5. Locate screw holes in the Economi\$er deck partition. Mount the differential enthalpy sensor onto the backside of the deck, directly behind the outdoor air enthalpy sensor (already installed) as shown in Fig. 1 and 2. Use the screws provided.
6. Remove the 620-ohm resistor that connects “SR+” and “SR” on the Economi\$er IV controller.
7. Route the control wires from the Economi\$er IV controller to the differential enthalpy sensor. Connect the blue and orange wires to the Economi\$er control board terminals labeled “SR+” (blue) and “SR” (orange). (See Fig. 4.) Route the wires through the grommet installed in Step 3. The grommet seals this hole air-tight while allowing the wires to pass through.
8. Connect the blue and orange wires to the differential enthalpy sensor. Connect the blue wire to the “+” terminal and the orange wire to the “S” terminal on the enthalpy sensor. (See Fig. 5.)
9. Reinstall the Economi\$er hood and inlet screens, if removed in Step 2.
10. Restore power to the unit and configure the Economi\$er IV controller per the Configuration section in this manual.

## Differential Enthalpy Sensor Installation for 48/50PG20-28, 48/50PM20-28, 48/50HJ020-028, and 551A/581A210-300 Units

1. Turn off power to unit and install Lockout Tag.
2. Remove the damper motor access panel at the back of the unit. (See Fig. 3.) Save the screws for later use.
3. Drill a  $\frac{7}{8}$  in. hole in the EconomiSer block-off panel, as shown in Fig. 9. Install the supplied grommet into the hole.



C07405

**Fig. 9 - EconomiSer IV Block-Off Panel Location -  
48/50PG20-28, 48/50PM20-28, 48/50HJ020-028,  
and 551A/581A210-300 Units**

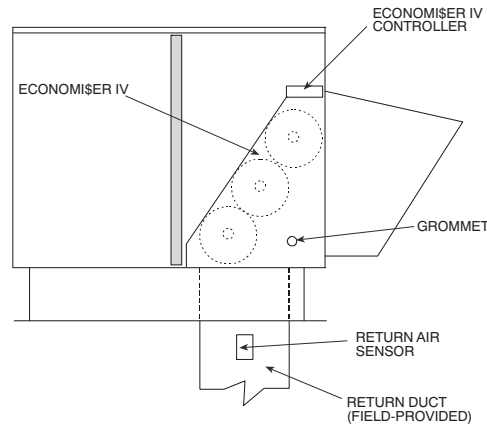
4. If there is a pre-existing differential temperature sensor, remove the sensor. To remove the sensor, disconnect the blue and orange wires from the differential temperature sensor and let them hang. They are used later to connect the differential enthalpy sensor.
5. Locate holes on the back (return air) side of the EconomiSer IV frame and mount the differential enthalpy sensor on the frame. Use the screws provided.
6. Remove the 620-ohm resistor that connects "SR+" and "SR" on the EconomiSer IV controller.
7. Route the control wires from the EconomiSer IV controller to the differential enthalpy sensor. Connect the blue and orange wires to the EconomiSer IV control board terminals labeled "SR+" (blue) and "SR" (orange). (See Fig. 4.) Route the wires through the grommet installed in Step 3. The grommet seals this hole air-tight while allowing the wires to pass through.
8. Connect the blue and orange wires to the differential enthalpy sensor. Connect the blue wire to the "+" terminal and the orange wire to the "S" terminal on the enthalpy sensor. (See Fig. 6.)
9. Replace the damper motor access panel. Secure panel with the screws saved from Step 2.
10. Restore power to the unit and configure the EconomiSer IV controller. See the Configuration section.

**Differential Enthalpy Sensor Installation  
Instructions for 48/50TC04-16,  
48/50HC04-14, 50TCQ04-14, 50HCQ04-12,  
48/50HE,TF,TM003-014, 48/50HJ004-014,  
50HEQ,HJQ004-012, TFQ004-012,  
558J/580J04-16, 548J04-14, 581/551J04-14,  
549J04-12, 548F/549B036-120,  
551B,C/558F/580F/581B,C024-151 Units**

**NOTE:** This section assumes you are starting with an Economi\$er IV installed in the rooftop and equipped with a single enthalpy sensor (p/n HH57AC078) installed, regardless of whether the Economi\$er came that way or you have completed the installation of an accessory sensor. If you do not already have a single enthalpy sensor installed, first install the single enthalpy sensor as described earlier in this instruction.

1. Turn off power to unit and install Lockout Tag.
2. Depending on the type of panels the unit is equipped with:
  - a. Units with standard panels —  
Remove the Economi\$er hood from the base unit and save the screws for Step 9a.
  - b. Units with factory-installed hinged panels —  
Open the hinged panel and secure it. Since the panel is hinged, do not remove it from the unit.

3. Using the screws provided in the CRENTDIF004A00 kit, mount the differential enthalpy sensor in the return air duct as shown in Fig. 10.
4. Remove the 620-ohm resistor that connects “SR+” and the “SR” terminals on the Economi\$er IV controller.
5. Route the red and black wires (provided in the CRENTDIF004A00 kit) between the Economi\$er IV controller and the installed location of the differential enthalpy sensor.
6. Connect the red wire to the “S” terminal and the black wire to the “+” terminal on the sensor. (See Fig. 5.)
7. Connect the red wire to the “SR” terminal and the black wire to the “SR+” terminal on the Economi\$er IV controller. (See Fig. 4.)
8. Restore power to the unit and configure the Economi\$er IV controller per the Configuration section of this manual.
9. Depending on the type of panels the unit is equipped with:
  - a. Units with standard panels —  
Re-install the Economi\$er hood.
  - b. Units with factory-installed hinged panels —  
Close the hinged panel and latch it.



**Fig. 10 - Return Air Enthalpy Sensor Mounting Location —  
48/50TC04-16, 48/50HC04-14, 50TCQ04-14, 50HCQ04-12 48/50HE,TF,TM003-014,  
48/50HJ004-014, 50HEQ,HJQ004-012, TFQ004-012, 558J/580J04-16, 581/551J04-14,  
548J04-14, 549J04-12 ,548F/549B036-120, 551B,C/558F/580F/581B,C024-151 Units**

C07085

HH57AC078, CRENTDIF004A00

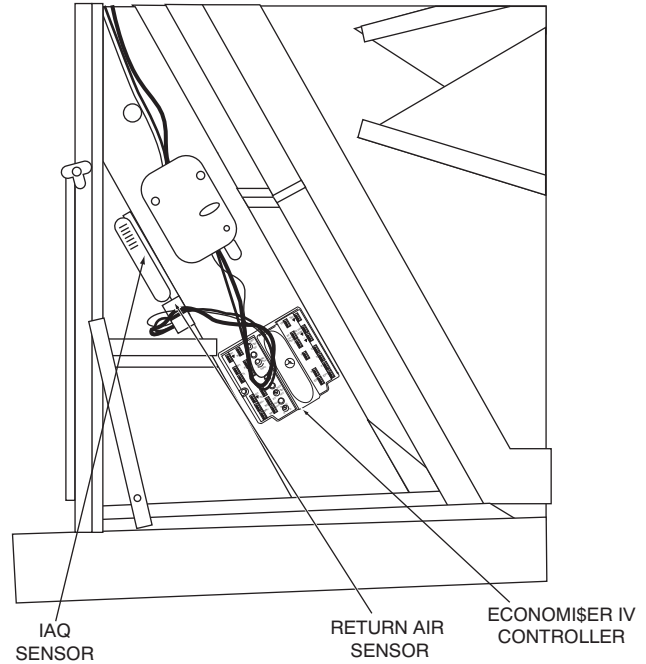
## Differential Enthalpy Sensor Installation

### Instructions for 48/50HJ015-017, 50HJQ014-016, 48/50TJ,TM016-028, 542J150-180, 551A/581A155-180, 558F/559F/579F/580F180-300 Units

**NOTE:** This section assumes you are starting with an Economi\$er IV installed in the rooftop and equipped with a single enthalpy sensor (p/n HH57AC078) installed. If you do not already have a single enthalpy sensor installed, first install the single enthalpy sensor as described earlier in this instruction.

1. Turn off power to unit and install Lockout Tag.
2. Remove the Economi\$er hood from the base unit and save the screws for Step 9.
3. Depending on the type of panels the unit is equipped with:
  - a. Units with standard panels —  
Access the Economi\$er by removing the return-air filter access panel. Save the screws for Step 11a.
  - b. Units with factory-installed hinged panels —  
Access the Economi\$er IV controller by opening the hinged return-air filter access panels and securing it. Since the panel is hinged, do not remove it from the unit.
4. Disconnect the black and red wires from the pre-existing temperature sensor and let them hang. Remove the air temperature sensor. The wires will be used later to connect to the enthalpy sensor.
5. Using the screws provided in the CRENTDIF004A00 kit, mount the differential enthalpy sensor to the Economi\$er frame. (See Fig. 10.)
6. Remove the 620-ohm resistor connected to the “SR+” and the “SR” terminals on the Economi\$er IV controller.
7. Connect the red wire, provided in the CRENTDIF004A00 kit, to the “S” terminal and the black wire, also provided, to the “+” terminal on the sensor. (See Fig. 5.)
8. Connect the red wire to the “SR” terminal and the black wire to the “SR+” terminal on the Economi\$er IV controller. (See Fig. 4.)

9. Re-install the Economi\$er hood using the screws from Step 2.
10. Restore power to the unit and configure the Economi\$er IV controller per the Configuration section of this manual.
11. Depending on the type of panels the unit is equipped with:
  - a. Units with standard panels —  
Re-install the return-air filter access panel using the screws from Step 3a.
  - b. Units with factory-installed hinged panels —  
Close the hinged panel and latch it.



C07406

**Fig. 11 - Return Air Enthalpy Sensor Mounting Location — 48/50HJ015-017, 50HJQ014-016, 48/50TJ,TM016-028, 542J150-180, 551A/581A155-180, 558F/559F/579F/580F180-300 Units**

# CONFIGURATION

## Outdoor Enthalpy Changeover Control

When the outdoor air enthalpy rises above the adjustable free cooling/enthalpy changeover set point, the outdoor-air damper moves to its minimum position. The free cooling/enthalpy changeover set point is set with the free cooling/enthalpy changeover set point potentiometer on the EconomiSer IV controller. The set points are A, B, C, and D. (See Fig. 12 and 13.) The factory-installed 620-ohm jumper must be in place across terminals SR and SR+ on the EconomiSer IV controller. (See Fig. 4.)

## Differential Enthalpy Control

The EconomiSer IV controller compares the outdoor air enthalpy to the return air enthalpy to determine whether to select the lower enthalpy air (return or outdoor) for cooling purposes. For example, when the outdoor air has a lower enthalpy than the return air and is below the set point, the EconomiSer IV brings in outdoor air for free cooling.

When using this mode of changeover control, turn the free cooling/enthalpy changeover set point potentiometer fully clockwise to the D setting.

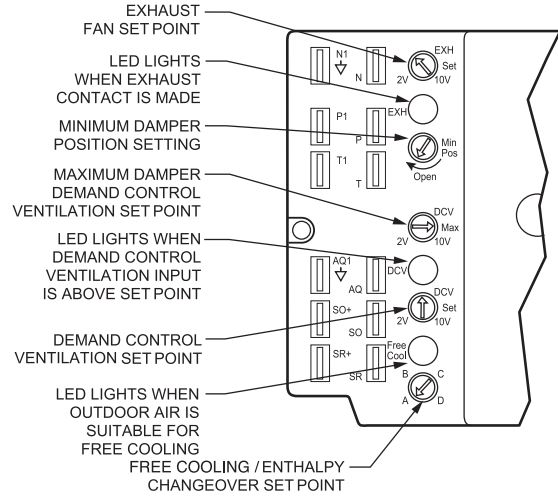


Fig. 12 - EconomiSer IV Controller Potentiometer and LED Locations

C07385

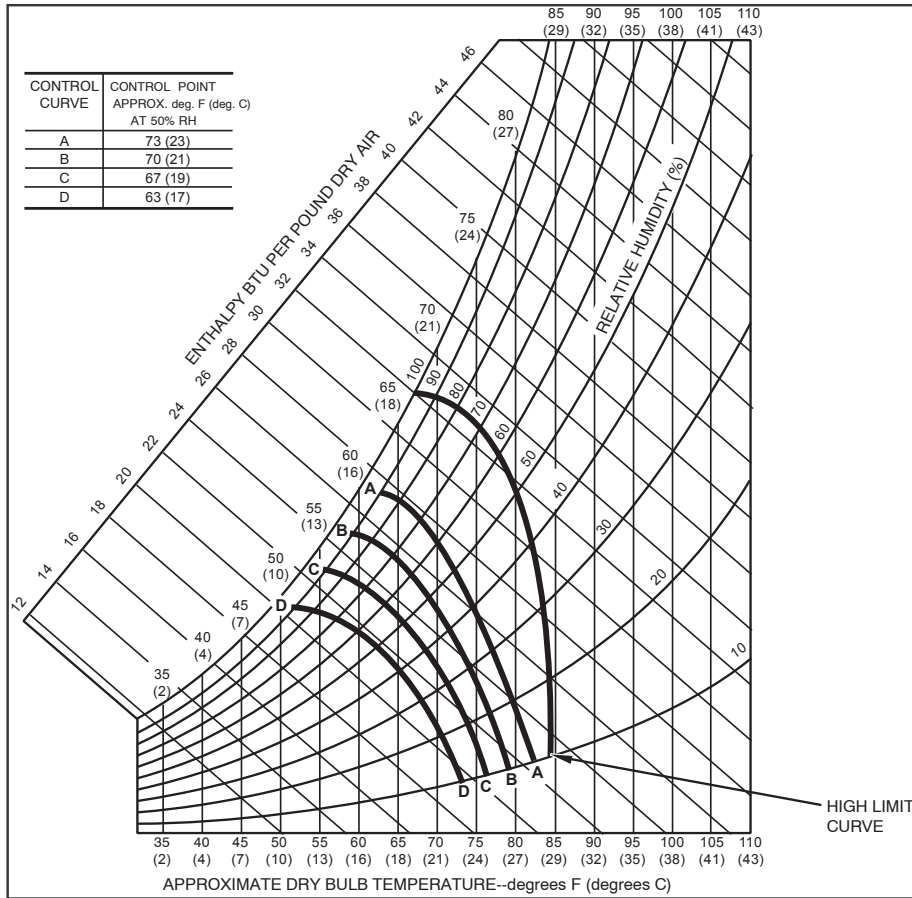


Fig. 13 - Enthalpy Changeover Set Points

C06037

HH57AC078, CRENTDIF004A00