

**KGAVT0701CVT
KGAVT0801CVT**

CONCENTRIC VENT TERMINATION KITS

Installation Instructions



NOTE: Read the entire instruction manual before starting the installation. **KEEP THESE INSTRUCTIONS WITH THE FURNACE.**

SAFETY CONSIDERATIONS

Installing and servicing heating equipment can be hazardous due to gas and electrical components. Only trained and qualified personnel should install, repair, or service heating equipment.

Untrained personnel can perform basic maintenance functions such as cleaning and replacing air filters. All other operations must be performed by trained service personnel. When working on heating equipment, observe precautions in the literature, on tags, and on labels attached to or shipped with the unit, and other safety precautions that may apply.

Follow all safety codes. In the United States, follow all safety codes including the National Fuel Gas Code (NFGC) NFPA 54/ANSI Z223.1-2006. In Canada, refer to the National Standard of Canada, Natural Gas and Propane Installation Codes (NSCNGPIC), CAN/CGA-B149.1 and 2.

Wear safety glasses and work gloves. Have a fire extinguisher available during start-up, adjustment procedures, and service calls.

Recognize safety information. This is the safety-alert symbol . When you see this symbol on the furnace and in instructions or manuals, be alert to the potential for personal injury.

Understand the signal words **DANGER**, **WARNING**, **CAUTION**, and **NOTE**. The words **DANGER**, **WARNING**, and **CAUTION** are used with the safety-alert symbol. **DANGER** identifies the most serious hazards which will result in severe personal injury or death. **WARNING** signifies hazards which could result in personal injury or death. **CAUTION** is used to identify unsafe practices which would result in minor personal injury, or product and property damage. **NOTE** is used to highlight suggestions which will result in enhanced installation, reliability, or operation.

WARNING

ELECTRICAL SHOCK HAZARD

Failure to follow this warning could result in personal injury or death.

Before beginning any installation, be sure the main electrical disconnect switch is in the OFF position.

SPECIAL VENTING REQUIREMENTS FOR INSTALLATIONS IN CANADA

Installation in Canada must conform to the requirements of CSA B149 code. Vent systems **must** be composed of pipe, fittings, cements, and primers listed to ULC S636. This concentric vent termination kit has been certified to ULC S636 for use with those IPEX PVC vent components which have been certified to this standard. In Canada, the primer and cement must be of the same manufacturer as the vent system. *IPEX System 636™, PVC/CPVC Primer, Purple Violet for Flue Gas Venting and IPEX – System 636™, PVC Cement for Flue Gas Venting, rated Class IIA, 65° C must be used with this venting system.

Do not mix primers and cements from one manufacturer with a vent system from a different manufacturer.

Follow the manufacturer's instructions in the use of primer and cement and never use primer or cement beyond its expiration date.

The safe operation, as defined by ULC S636, of the vent system and this termination kit is based on following these installation instructions, the vent system manufacturer's installation instructions, and proper use of primer and cement.

All fire stop and roof flashing used with this system must be UL listed material.

Acceptability under Canadian standard CSA B149 is dependent upon full compliance with all installation instructions. Under this standard, it is recommended that the vent system be checked once a year by qualified service personnel.

The authority having jurisdiction (gas inspection authority, municipal building department, fire department, etc.) should be consulted before installation to determine the need to obtain a permit.

INTRODUCTION

This instruction covers installation of the concentric vent termination kits Part No. KGAVT0701CVT (2 in. / 51 mm) and KGAVT0801CVT (3 in. / 76 mm) on all gas-fired condensing furnaces. Use vent and termination kit combinations as stated in the furnace Installation and Start-Up Literature.

NOTE: If these instructions differ from those packaged with the furnace, follow these instructions.

*IPEX System 636™ is a trademark of IPEX Inc.

Table 1 – Kit Contents

DESCRIPTION	KIT PART NO. AND QUANTITY	
	KGAVT0701CVT	KGAVT0801CVT
2–In. (51 mm) Rain Cap	1	—
3–In. (76 mm) Rain Cap	—	1
2–In. (51 mm) Dia. Pipe 31–5/8 in. (16 mm) long	1	—
3–In. (51 mm) Dia. Pipe 19–1/2 in. (495 mm) long	1	—
2–1/2 In. (64 mm) Dia. Pipe 37–1/8 in. (943 mm) long	—	1
4–In. (102 mm) Dia. Pipe 24 in. (610 mm) long	—	1
2–In. (51 mm) Y Concentric Fitting	1	—
3–In. (76 mm) Y Concentric Fitting	—	1
Installation Instructions	1	1

DESCRIPTION AND USAGE

Two concentric combustion-air and vent pipe termination kits are available. The 2-in. (51 mm) kit Part No. KGAVT0701CVT can be used for 1-, 1-1/2, 2-, or 2-1/2 in. (25-, 38-, 51-, or 64 mm) diameter pipe systems. The 3-in. (76 mm) kit Part No. KGAVT0801CVT is for 2-1/2 or 3-in. (64 or 76 mm) diameter pipe systems. (See Fig. 3 and 6 for different applications.) Both combustion-air and vent pipes must attach to the termination kit. The termination kit must terminate outside the structure and must be installed as in one of the installations shown in Fig. 3, 6, 8, or 9. Roof termination is preferred since it is less susceptible to damage, reduces the chance of intaking contaminants, and has less visible vent vapors.

⚠ WARNING

UNIT DAMAGE AND PROPERTY DAMAGE HAZARD

Failure to follow this warning could result in unit damage, property damage, personal injury or death.

These kits are to be used only for terminating condensing Category IV vent furnaces. DO NOT use kits to terminate Category I, II, or III vent furnaces.

Field-supplied pipe and fittings are required to complete the installation.

In the USA, combustion-air and vent pipe fittings must conform to American National Standards Institute (ANSI) and American Society for Testing and Materials (ASTM) standards D1785 (schedule-40 PVC), D2665 (PVC-DWV), D2441 (SDR-21 and SDR-26 PVC), D2661 (ABS-DWV), or F628 (schedule-40 ABS). Pipe cement and primer must conform to ASTM standards D2564 (PVC) or D2235 (ABS). See section for Special Venting Requirements for Installations in Canada for pipe, fittings, cement, and primer material requirements for Canadian installations.

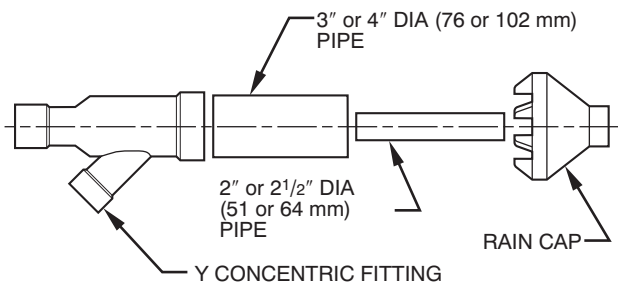

Fig. 1 - Kit Components

A08481

INSTALLATION

Step 1 — ROOF TERMINATION

1. Determine pipe diameter from tables in furnace Installation and Start-Up Instructions.
2. Determine appropriate concentric vent termination kit for pipe diameter selected. See Description and Usage section.
3. Determine best location for termination kit.

NOTE: Roof termination is preferred since it is less susceptible to damage, reduces the chance of intaking contaminants, and has less visible vent vapors.

4. Cut 1 hole (4-in. / 102 mm dia.) for KGAVT0701CVT (2-in. / 51 mm) kit, or 1 hole (5-in. / 127 mm dia.) for KGAVT0801CVT (3-in. / 76 mm) kit.
 - a. Plastic venting systems shall not pass through rated fire separations.
5. Partially assemble concentric vent termination kit. Clean and cement using procedures found in furnace Installation and Start-Up Instructions.
 - b. Cement Y concentric fitting to larger diameter kit pipe. (See Fig. 1.)
 - c. Cement rain cap to smaller diameter kit pipe. (See Fig. 1.)

NOTE: Instead of cementing the smaller pipe to the rain cap, a field-supplied stainless steel screw may be used to secure the 2 components together when field disassembly is desired for cleaning. (See Fig. 4.)

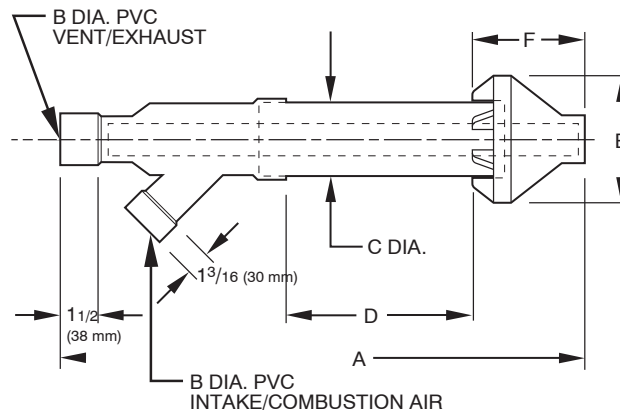

Fig. 2 - Concentric Vent Dimensional Drawing

A08482

Table 2 – Dimensions - In. (mm)

KIT PART NO.	A*	B	C	D	E	F
KGAVT0701CVT	33–3/8 (848)	2 (51)	3–1/2 (89)	16–5/8 (422)	6–1/4 (159)	5–3/4 (146)
KGAVT0801CVT	38–7/8 (987)	3 (76)	4–1/2 (114)	21–1/8 (537)	7–3/8 (187)	6–1/2 (165)

*Dimension A will change accordingly as dimension D is lengthened or shortened.

In the USA, Dimension D may be lengthened to 60 in. (1524 mm) maximum. Dimension D may also be shortened by cutting the pipes provided in the kit to 12 in. (305 mm) minimum.

⚠ WARNING

CARBON MONOXIDE POISONING HAZARD

Failure to follow this warning could result in personal injury or death.

When using alternate screw assembly method, drill clearance hole in rain cap and pilot hole in vent pipe for screw size being used. Failure to drill adequate holes may cause cracking of PVC components, allowing combustion products to be recirculated.

⚠ WARNING

CARBON MONOXIDE POISONING HAZARD

Failure to follow this warning could result in personal injury or death.

Do not operate the furnace with rain cap removed or recirculation of combustion products may occur. Water may also collect inside larger combustion-air pipe and flow to the burner enclosure.

6. Install Y concentric fitting pipe assembly through structure's hole and field-supplied roof boot/flashing.

NOTE: Do not allow insulation or other materials to accumulate inside pipe assembly when installing through hole.

7. Secure assembly to roof structure as shown in Fig. 5 using field-supplied metal strapping or equivalent support material.

NOTE: Ensure termination height is above the roof surface or anticipated snow level (1 ft. (0.3 M) in USA. or 1-1/2 ft. (0.32 M) in Canada) as shown in Fig. 3.

NOTE: In the USA, if assembly is too short to meet height requirement, the 2 pipes supplied in the kit may be replaced by using same diameter, field-supplied SDR-26 PVC (D2241) pipe. Do not extend dimension D more than 60 in. (1524 mm)(See Fig. 2.)

⚠ CAUTION

UNIT MAY NOT OPERATE HAZARD

Failure to follow this caution may result in intermittent unit operation.

DO NOT use field-supplied couplings to extend pipes. Airflow restriction will occur and the furnace pressure switch may cause intermittent operation.

8. Install rain cap and small diameter pipe assembly in roof penetration assembly. Ensure small diameter pipe is cemented and bottomed in Y concentric fitting.

9. Cement furnace combustion-air and vent pipes to concentric vent termination assembly. See Fig. 5 for proper pipe attachment.
10. Operate furnace through 1 heat cycle to ensure combustion-air and vent pipes are properly connected to concentric vent termination connections.

Step 2 — SIDE WALL TERMINATION

1. Determine pipe diameter from tables in furnace Installation and Start-Up Instructions.
2. Determine appropriate concentric vent termination kit for pipe diameter selected. See Description and Usage section.
3. Determine best location for termination kit. (See Fig. 6.)

NOTE: Considerations for the following should be used when determining an appropriate location for the termination kit:

- a. Termination kit positioned where the vent vapors will not damage plants/shrubs or air conditioning equipment.
 - b. Termination kit positioned so it will not be affected by wind eddy that may allow recirculation of combustion products, or airborne leaves, or light snow.
 - c. Termination kit positioned where it will not get damaged or be subjected to foreign objects, such as stones, balls, etc.
 - d. Termination kit positioned where the vent vapors will not be objectionable.
4. Cut 1 hole (4-in. / 102 mm dia.) for KGAVT0701CVT (2-in. / 51mm) kit, or 1 hole (5-in. / 127 mm diameter) for KGAVT0801CVT (3-in. / 76 mm) kit.
 - a. Plastic venting systems shall not pass through rated fire separations.
 5. Partially assemble concentric vent termination kit. Clean and cement using procedures found in furnace Installation and Start-Up Instructions.
 - a. Cement Y concentric fitting to larger kit pipe.
 - b. Cement rain cap to smaller diameter kit pipe.

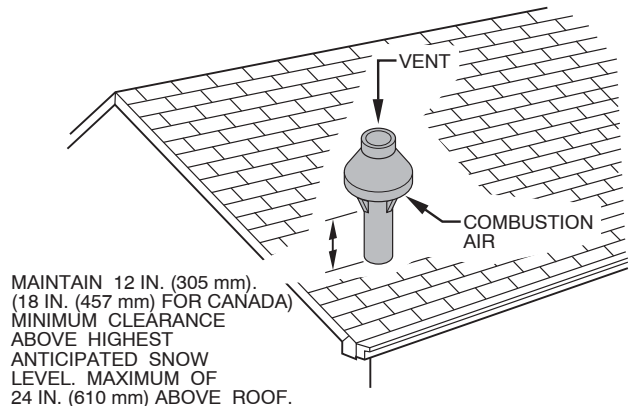

Fig. 3 - Concentric Vent and Combustion-Air Termination, Roof Termination (Preferred)

A93054

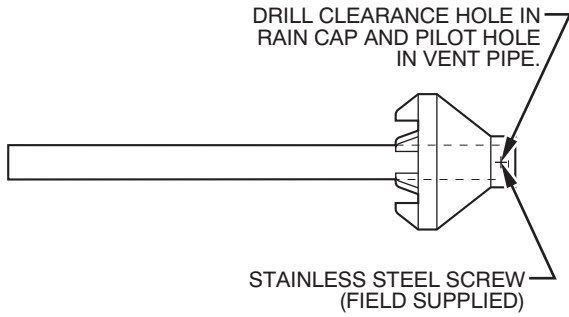

Fig. 4 - Rain Cap to Vent Pipe Alternate Assembly

A93390

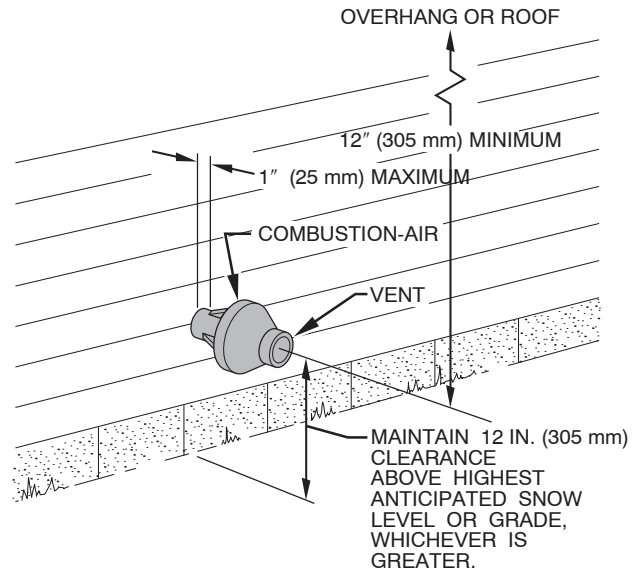
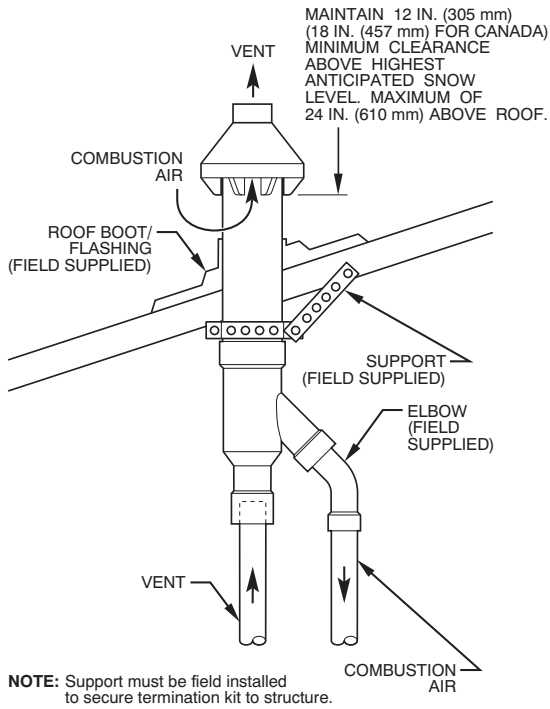

Fig. 6 - Concentric Vent and Combustion-Air Side Wall Termination

A93055



NOTE: Support must be field installed to secure termination kit to structure.

Fig. 5 - Concentric Vent Roof Installation

A93391

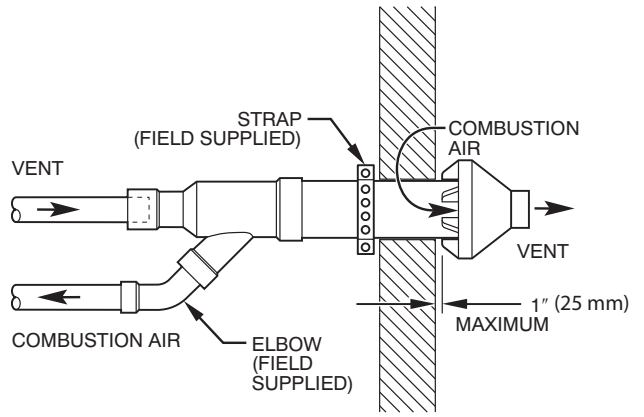

NOTE: Securing strap must be field installed to prevent movement of termination kit in side wall.

Fig. 7 - Concentric Vent Side Wall Attachment

A93392

NOTE: Instead of cementing smaller pipe to the rain cap, a field-supplied stainless steel screw may be used to secure the 2 components together when field disassembly is desired for cleaning. (See Fig. 4.)

⚠ WARNING

CARBON MONOXIDE POISONING HAZARD

Failure to follow this warning could result in personal injury or death.

Failure to drill adequate holes may cause cracking of PVC components, allowing combustion products to be recirculated. When using alternate screw assembly method, drill clearance hole in rain cap and pilot hole in vent pipe for screw size being used.

⚠ WARNING

CARBON MONOXIDE POISONING HAZARD

Failure to follow this warning could result in unit damage, personal injury or death.

Do not operate furnace with rain cap removed or recirculation of combustion products may occur. Water may also collect inside larger combustion-air pipe and flow to the burner enclosure.

6. Install Y concentric fitting and pipe assembly through structure's hole.

NOTE: Do not allow insulation or other materials to accumulate inside pipe assembly when installing through hole.

7. Install rain cap and small diameter pipe assembly in Y concentric fitting and large paper assembly. Ensure small diameter pipe is bottomed and cemented in Y concentric fitting.
8. Secure assembly to structure as shown in Fig. 7 using field-supplied metal strapping or equivalent support material.

NOTE: Ensure termination location clearance dimensions are as shown in Fig. 6.

NOTE: In USA, if assembly needs to be extended to allow side wall thickness requirement, the 2 pipes supplied in the kit may be replaced by using same diameter, field-supplied SDR-26 PVC (D2241) pipe. Do not extend dimension D more than 60 in. (1524 mm) (See Fig. 2.)

⚠ CAUTION

UNIT MAY NOT OPERATE HAZARD

Failure to follow this caution may result in intermittent unit operation.

DO NOT use field-supplied couplings to extend pipes. Airflow restriction will occur and the furnace pressure switch may cause intermittent operation.

9. Cement furnace combustion-air and vent pipes to concentric vent termination assembly. See Fig. 7 for proper pipe attachment.
10. Operate furnace through 1 heat cycle to ensure combustion-air and vent pipes are properly connected to concentric vent termination connections.

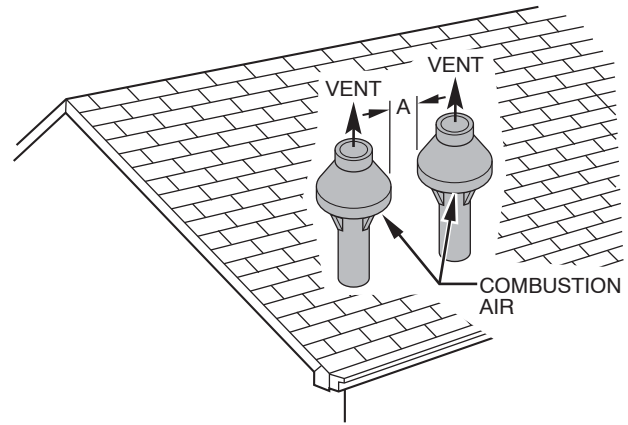

A93056

Fig. 8 - Concentric Vent and Combustion-Air Roof Termination (Dimension A as Touching or 2-in. (51 mm) Maximum Separation)

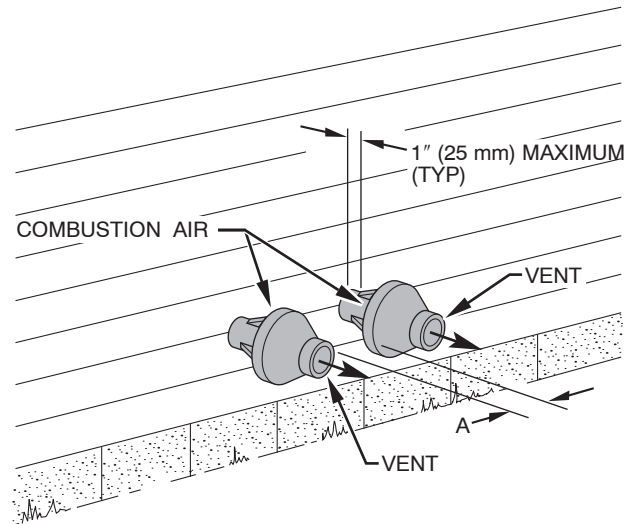

A93057

Fig. 9 - Concentric Vent and Combustion-Air Roof Termination (Dimension A as Touching or 2-in. (51 mm) Maximum Separation)

Step 3 — MULTI-VENTING TERMINATIONS

When 2 or more direct vent furnaces are vented near each other, each furnace must be individually vented. (See Fig. 8 and 9.) NEVER common vent or breach vent this furnace. When 2 or more direct vent furnaces are vented near each other, 2 vent terminations may be installed as shown in Fig. 8 and 9, but next to vent termination must be at least 36 in. (914 mm) away from first 2 termination. It is important that vent terminations be made as shown to avoid recirculation of flue gases. Dimension A in Fig. 8 and 9 represents distance between pipes or rain shields, as touching or 2-in. (51 mm) maximum separation.

