

# Installation Instructions

**NOTE:** Read the entire instruction manual before starting the installation.

## SAFETY CONSIDERATIONS

Improper installation, adjustment, alteration, service, maintenance, or use can cause explosion, fire, electrical shock, or other conditions which may cause death, personal injury, or property damage. Consult a qualified installer, service agency, or your distributor or branch for information or assistance. The qualified installer or agency must use factory-authorized kits or accessories when modifying this product. Refer to the individual instructions packaged with the kits or accessories when installing.

Follow all safety codes. Wear safety glasses, protective clothing, and work gloves. Have a fire extinguisher available. Read these instructions thoroughly and follow all warnings or cautions include in literature and attached to the unit. Consult local building codes, the current editions of the National Fuel Gas Code (NFGC) NFPA 54/ANSI Z223.1 and the National Electrical Code (NEC) NFPA 70.

In Canada, refer to the current editions of the National Standards of Canada CAN/CGA-B149.1 and .2 Natural Gas and Propane Installation Codes, and Canadian Electrical Code CSA C22.1

Recognize safety information. This is the safety-alert symbol . When you see this symbol on the unit and in instructions or manuals, be alert to the potential for personal injury.

Understand the signal words **DANGER**, **WARNING**, and **CAUTION**. These words are used with the safety-alert symbol. **DANGER** identifies the most serious hazards which **will** result in severe personal injury or death. **WARNING** signifies hazards which **could** result in personal injury or death. **CAUTION** is used to identify unsafe practices which **may** result in minor personal injury or product and property damage. **NOTE** is used to highlight suggestions which **will** result in enhanced installation, reliability, or operation.

## WARNING

### FIRE, EXPLOSION, ELECTRICAL SHOCK HAZARD

Failure to follow this warning could result in personal injury, death and/or property damage.

Before installing or servicing unit, always turn off main electrical and gas to unit and tag with appropriate lockout. There may be more than one disconnect switch.

## CAUTION

### CUT HAZARD

Failure to follow this caution may result in personal injury.

Sheet metal parts may have sharp edges or burrs. Use care and wear appropriate protective clothing, safety glasses and gloves when handling parts and servicing furnaces.

## CAUTION

### UNIT DAMAGE HAZARD

Failure to follow this caution may result in improper and dangerous operation.

Label all wires prior to disconnection when servicing controls.

## INTRODUCTION

This instruction covers installation of the permanent split capacitor (PSC) inducer motor kit Part No. 317292-753 for use in condensing gas furnaces. See the appropriate section for details on your furnace model.

**Section I:** Models 398A, 399A, 58DX, 58DXA, 58DXC, 58SX, 58SXA, and 58SXC 46-3/16-in. (1173 mm) tall condensing gas furnaces.

**Section II:** Models 340MAV, 340AAV, 345MAV, 350MAV, 350AAV, 351DAS, 353AAV, 490AAV, 58MCA, 58MCB, 58MEB, 58MSA, 58MXA, 58MXB, PG9MAA and PG9MAB 40-in. (1016 mm) tall condensing gas furnaces except for 140 size units which require high output motor HC27CB118.

## DESCRIPTION AND USAGE

Use this PSC motor kit to repair units with an inducer motor requiring replacement. This kit is designed to allow replacement of inducer motor **ONLY**.

This PSC inducer motor kit contains the following items:

Motor HC27CB120	1
Capacitor HC91PD001	1
Slinger Ring*	1
Foam Rubber Seal*	1
Harness (Amp Connector)	1
Harness (Molex Connector)	1
Moisture Shield	1

\*Parts for use on cover plate Part No. 308118-402 only.

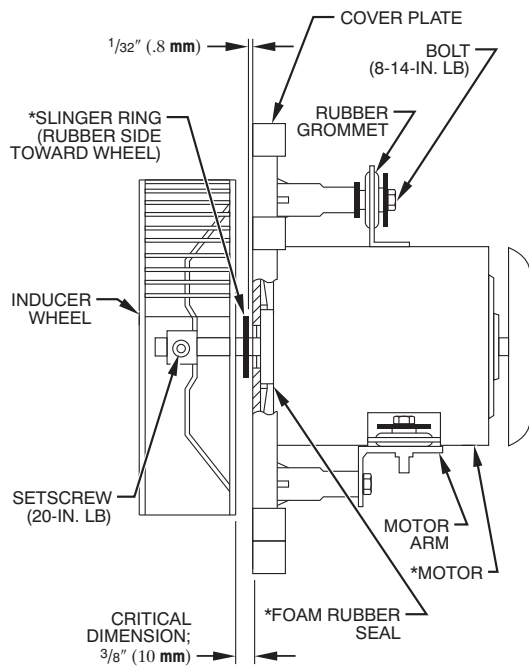

\* Parts included in kit. Wire adapter not shown.

A95487

**Fig. 1 - Inducer Motor Assembly with Cover Plate  
308118-402**

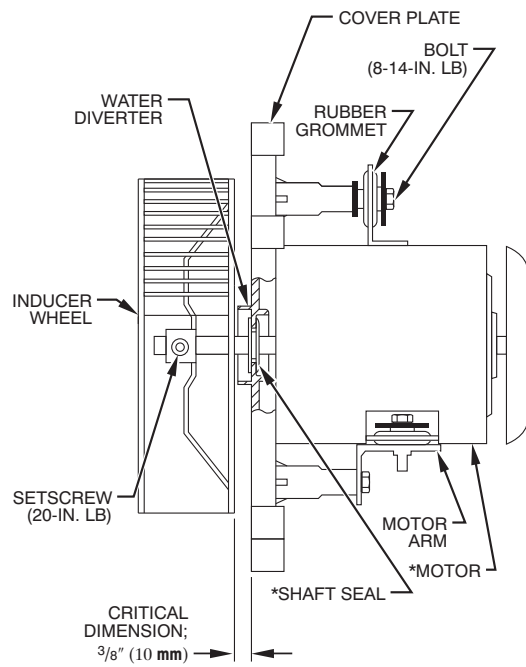

\* Parts included in kit. Wire adapter not shown.

A95488

**Fig. 2 - Inducer Motor Assembly with Cover Plate  
308118-403 or -405**

## INSTALLATION

### SECTION I: MODELS 398A, 399A, 58DX, 58DXA, 58DXC, 58SX, 58SXA, AND 58SXC 46-3/16-IN. (1173 mm) TALL CONDENSING GAS FURNACES

**NOTE:** If the inducer cover plate or wheel require replacement, use inducer motor kit Part No. 309868-755.

This kit may be used on furnaces with inducer motor cover plate Part No. 308118-402, 403, or 405. (See Fig. 1 and 2.) The cover plate part no. is located on motor side of cover plate.

#### Step 1 — Remove Old Motor Assembly

1. Turn off gas and electrical supplies to unit.
2. Remove control access door.
3. Disconnect wiring from motor.
4. Remove screw securing motor ground wire and inducer control box ground wire (when used). The ground screw may be located either on blower shelf or on top mounting bracket of inducer assembly. (See Fig. 3.)
5. Remove screws securing left mounting bracket to collector box and plastic inducer housing.
6. Remove screw securing top mounting bracket to coupling box. (See Fig. 3.)
7. Remove 8 screws securing plastic cover plate to inducer housing. Remove and save top mounting bracket. (See Fig. 3.)
8. Carefully remove motor assembly from inducer housing.
9. Loosen setscrew in inducer wheel and remove wheel.

**NOTE:** One of 3 bolts securing motor to the plastic inducer cover plate threads into this plastic plate. Locate and mark this bolt before proceeding.

10. Remove 3 bolts securing motor to inducer cover plate assembly and remove motor.

#### Step 2 — Install New Motor on Cover Plate Part No. 308118-402

1. Remove rubber grommets from old motor and install on new motor.
2. Remove old foam rubber seal from cover plate and install new foam rubber seal.
3. Install new motor on inducer cover plate. (See Fig. 1.) Secure motor with 3 bolts previously removed, ensuring that bolt marked in Step 1, item 10 is used in plastic cover plate hole.
4. Slide slinger ring onto motor shaft with rubber side facing inducer wheel as shown in Fig. 1. Ensure clearance between ring and cover plate is 1/32-in. (.8 mm).
5. Position inducer wheel on motor shaft with setscrew on flat portion of shaft. Ensure clearance between wheel and cover plate is 3/8-in. (10 mm). (See Fig. 1.) Tighten setscrew.
6. Ensure cover plate gasket is in good condition and replace if necessary. Install motor/cover plate assembly in inducer housing.
7. Reinstall top mounting bracket on coupling box and inducer housing. Secure ground wire(s) under bracket screw on housing if previous motor was grounded in this manner. Otherwise, ground motor to blower shelf. (See Fig. 3.)
8. Reinstall left mounting bracket on coupling box and inducer housing. Secure cover plate to inducer housing with remaining screws. (See Fig. 3.)
9. Connect motor lead connector.
  - a. This kit contains a PSC motor and capacitor. Position capacitor in a convenient location using screw to attach securely.
  - b. Select appropriate wire adapter and connect motor leads to inducer control or furnace wire harness.
10. Turn on gas and electrical supplies to furnace.
11. Check furnace operation through 2 complete cycles.
12. Reinstall control access door.

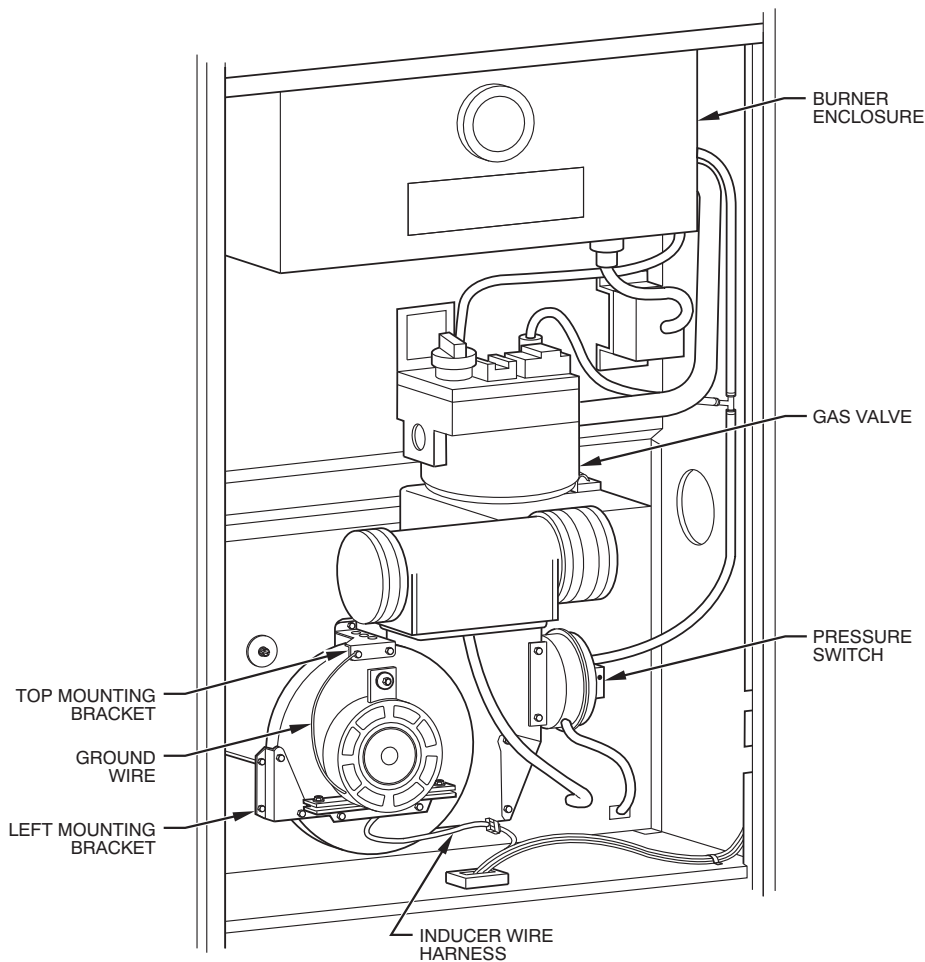

317292

**Fig. 3 - Component Location in 46-3/16-in. (1173 mm) Tall Condensing Furnace (Upflow Orientation Shown)**

A87429

**Step 3 — Install New Motor on Cover Plate Part No. 308118-403 or -405**

**NOTE:** Ensure shaft seal in 308118-403 or -405 cover plate is in good condition and seals properly. (See Fig. 2.)

1. Remove rubber grommets from old motor and install on new motor.
2. Remove shaft seal in cover plate.
3. Install new shaft seal in cover plate.
4. Install new motor on inducer cover plate. (See Fig. 2.) Secure motor with 3 bolts previously removed, ensuring that bolt marked in Step 1, item 10 is used in plastic cover plate.
5. Position inducer wheel on motor shaft with setscrew on flat portion of shaft. Ensure clearance between wheel and cover plate is 3/8-in. (10 mm) (See Fig. 2.) Tighten setscrew.
6. Ensure cover plate gasket is in good condition and replace if necessary. Install motor/cover plate assembly in inducer housing.
7. Reinstall top mounting bracket on coupling box and inducer housing. Secure ground wire(s) under bracket screw on housing if previous motor was grounded in this manner. Otherwise, ground motor to blower shelf. (See Fig. 3.)
8. Reinstall left mounting bracket on coupling box and inducer housing. Secure cover plate to inducer housing with remaining screws. (See Fig. 3.)
9. Connect motor lead connector.

- a. This kit contains a PSC motor and capacitor. Position capacitor in a convenient location using screws to attach securely.
  - b. Select appropriate wire adapter and connect motor leads to inducer control or furnace wire harness.
10. Turn on gas and electrical supplies to furnace.
  11. Check furnace operation through 2 complete cycles.
  12. Reinstall control access door.

**SECTION II: MODELS 340MAV, 340AAV, 345MAV, 350MAV, 350AAV, 351DAS, 353AAV, 490AAV, 58MCA, 58MCB, 58MEB, 58MSA, 58MXA, 58MXB, PG9MAA AND PG9MAB 40-IN. (1016 MM) TALL CONDENSING GAS FURNACES**

**Step 1 — Remove Old Motor Assembly**

1. Turn off gas and electrical supplies to furnace.
2. Remove main furnace door.
3. Remove drain tube from inducer motor mounting cover plate. (See Fig. 4.)
4. Remove pressure switch tubes. (See Fig. 4.)
  - a. Remove 1 tube attached to pressure switch from collector box.
  - b. Remove 1 tube attached to pressure switch from burner enclosure and gas valve.
5. Remove wires from pressure switch.
6. Disconnect inducer motor lead connector from control center.

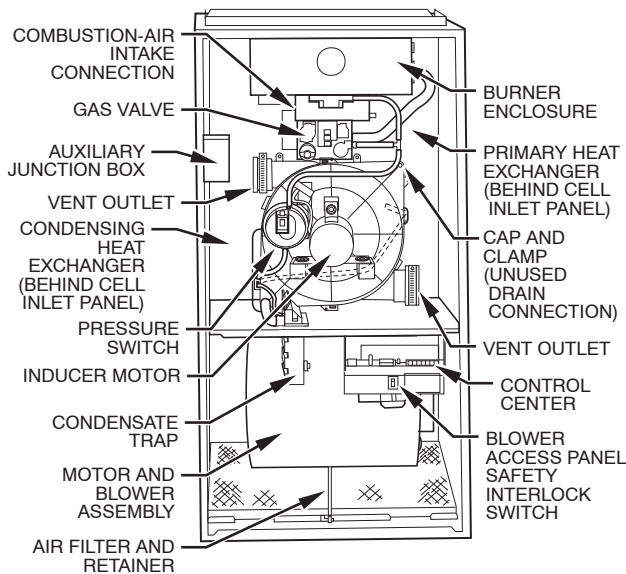

A98401

**Fig. 4 - Component Location in 40-in. (1016 mm) Tall Condensing Furnace (Upflow Orientation Shown)**

7. Remove inducer motor mounting cover plate from inducer housing by pushing tabs to release. Remove screws next to tabs if used.
8. Loosen setscrew in inducer wheel and remove wheel.
9. Remove 3 bolts securing motor to inducer cover plate and remove motor.

### Step 2 — Install New Motor Assembly

1. Remove rubber grommets from old motor and install on new motor.
2. Remove shaft seal in cover plate.
3. Install new shaft seal in cover plate.
4. Install new motor on inducer cover plate. (See Fig. 5.) Secure motor to plastic cover plate with 3 bolts previously removed.
5. Position inducer wheel on motor shaft with setscrew on flat portion of shaft. (See Fig. 5.) Tighten setscrew.
6. Install new inducer motor mounting cover plate by locating tabs in retainer slots and pushing until engaged.

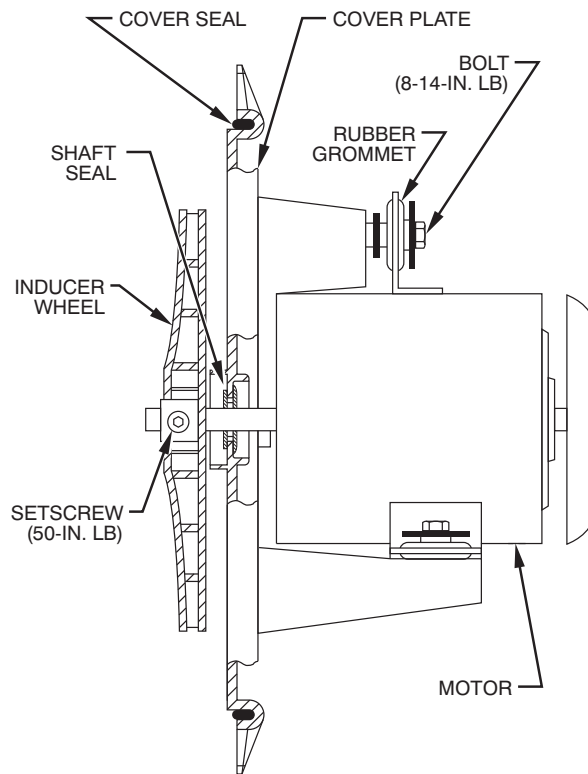

A95489

**Fig. 5 - Inducer Motor Assembly with Cover Plate**

**NOTE:** If the silicone seal between the inducer cover plate and housing is damaged in any way, it must be repaired. (See Fig. 5.) To repair, remove old silicone from housing and cover plate. Apply a sealant releasing agent such as PAM cooking spray or equivalent (must not contain corn or canola oil, halogenated hydrocarbons or aromatic content to prevent inadequate sealing) to inducer housing. Then apply a small bead of G.E. RTV 162, G.E. RTV 6702, G.E. 6808, or Dow-Corning RTV 738 sealant to groove in cover plate and reattach to housing. G.E. RTV 162 (P771-9003) is available through RCD in 3-oz. tubes.

**NOTE:** Use No. 8 - 18 X 1/2-in. LG thread-cutting screws to secure cover plate to housing, if required.

7. Reconnect pressure switch tubes. See tubing label on furnace for proper connections.
8. Reconnect pressure switch wires.
9. Reconnect inducer motor leads to control center.
10. Reconnect drain tube to inducer housing cover.
11. Turn on gas and electrical supplies to unit.
12. Check furnace operation through 2 complete cycles.
13. Reinstall main furnace door.