

**320721-765,
330539-751 THRU -757**

COUPLING BOX KIT

Installation Instructions

NOTE: Read the entire instruction manual before starting the installation.

SAFETY CONSIDERATIONS

Improper installation, adjustment, alteration, service, maintenance, or use can cause explosion, fire, electrical shock, or other conditions which may cause death, personal injury, or property damage. Consult a qualified installer, service agency, or your distributor or branch for information or assistance. The qualified installer or agency must use factory-authorized kits or accessories when modifying this product. Refer to the individual instructions packaged with the kits or accessories when installing. Follow all safety codes. Wear safety glasses, protective clothing, and work gloves. Have a fire extinguisher available. Read these instructions thoroughly and follow all warnings or cautions include in literature and attached to the unit. Consult local building codes, the current editions of the National Fuel Gas Code (NFGC) NFPA 54/ANSI Z223.1 and the National Electrical Code (NEC) NFPA 70.

In Canada, refer to the current editions of the National Standards of Canada CAN/CGA-B149.1 and .2 Natural Gas and Propane Installation Codes, and Canadian Electrical Code CSA C22.1

Recognize safety information. This is the safety-alert symbol . When you see this symbol on the unit and in instructions or manuals, be alert to the potential for personal injury.

Understand the signal words **DANGER**, **WARNING**, and **CAUTION**. These words are used with the safety-alert symbol. **DANGER** identifies the most serious hazards which **will** result in severe personal injury or death. **WARNING** signifies hazards which **could** result in personal injury or death. **CAUTION** is used to identify unsafe practices which **may** result in minor personal injury or product and property damage. **NOTE** is used to highlight suggestions which **will** result in enhanced installation, reliability, or operation.

WARNING

FIRE, EXPLOSION AND ELECTRICAL SHOCK HAZARD

Failure to follow this warning could result in personal injury, death and/or property damage.

Turn off gas and electrical supplies to unit before beginning any installation or modification. Follow operating instructions on label attached to furnace.

CAUTION

UNIT DAMAGE HAZARD

Failure to follow this caution may result in improper and dangerous operation.

Label all wires prior to disconnection when servicing controls.

INTRODUCTION

This instruction covers installation of the Coupling Box Kit Part No. 320721-765, 330539-751, -752, -753, -754, -755, -756, and -757 in 40-in. (1016 mm) tall condensing gas furnaces. See Table 1 for kit usage.

NOTE: A releasing agent such as PAM cooking spray or equivalent (must not contain corn or canola oil, halogenated hydrocarbons nor aromatic contents to prevent inadequate seal) and RTV sealant (G.E. 162, G.E. 6702, or Dow-Corning 738) are needed before starting installation. DO NOT substitute any other type of RTV sealant. G.E. 162 (P771-9003) is available through RCD in 3-oz. tubes.

DESCRIPTION AND USAGE

Use this Coupling Box Kit to replace failed coupling box assembly.

This coupling box kit contains the following items:

ITEM	QTY.
Coupling Box Assembly	1
Cold Spot Baffle	1
Screw (No. 8AB x 1/2-in. long hex head)	6 max.
Installation Instruction	1

INSTALLATION

Step 1 — Remove Whole Cell Panel Assembly

See Fig. 1 and Fig. 2 for furnace component locations. See Fig. 5 for expanded view of heating system components.

NOTE: Actual component locations may vary depending on model and series.

1. Turn off gas and electrical supplies to furnace.
2. Remove main furnace door.
3. Remove blower access panel.
4. Disconnect field power supply wires from J-box.
5. Remove two screws securing J-box.
6. Remove two screws securing top filler panel and rotate upwards to remove or allow the whole cell panel to be removed from front of furnace.
7. Disconnect combustion-air intake pipe from intake housing and move pipe out of furnace casing.

8. Disconnect gas supply pipe from gas valve using backup wrench.
9. Disconnect vent pipe from inducer housing by loosening coupling clamp on inducer outlet. If coupling has 2 clamps, loosen clamp on vent pipe side. Move pipe out of furnace casing.
10. If control center is located in burner compartment of furnace, remove motor leads, transformer wires, door switch wires, and auxiliary limit switch wires (if present) from control center and pull wires through blower shelf.
11. If control center is located in blower compartment of furnace, disconnect wires from flame sensor, hot surface igniter, overtemperature switch, gas valve, pressure switch(es), inducer motor, limit switch, and J-box, then pull wires through blower shelf.
12. Remove 2 screws securing blower to blower shelf.
13. Remove 2 screws next to blower mounting screws that secure blower shelf to cell panel.
14. Remove 3 screws from each side of cell panel.
15. If control center is located in burner compartment of furnace, remove control center by removing screw and pressing tabs inward.
16. If control center was removed from furnace casing, secure control center (and J-box) to manifold for removal purposes only.
17. Disconnect field drain connection from condensate trap.
18. Disconnect drain and relief port tube from condensate trap.
19. Remove whole cell panel assembly with heat exchanger, burner box, inducer assembly, J-box (if applicable), and control center (if applicable) attached through front of furnace.

⚠ CAUTION

PERSONAL INJURY HAZARD

Failure to follow this caution may result in personal injury.
Whole cell panel assembly is heavy. Get help to remove and lift assembly.

Step 2 — Remove Old Coupling Box and Cold Spot Baffle Assembly

1. Remove screws securing coupling box to cell panel and condensing heat exchanger.
2. Break seal between top flange of coupling box and cell panel using screwdriver blade.
3. Remove and discard old coupling box cover.
4. Loosen, but do not remove the 2 end screws that attach the cold spot baffle to the rear primary cell panel, and cold spot baffle. (See Fig. 4.)
5. Remove the remaining screws along the top edge that secure the cold spot baffle to the rear primary cell panel from whole cell panel assembly.

6. Remove and discard old cold spot baffle.
7. Clean old sealant from primary cell outlet panel and condensing heat exchanger.

Step 3 — Install New Cold Spot Baffle

1. Position cold spot baffle so curved bottom flange is facing condensing heat exchanger. Slide cold spot baffle under loose end screws.
2. Start screws that secure cold spot baffle to primary cell outlet panel. Use screws provided in kit.

⚠ WARNING

CARBON MONOXIDE POISONING HAZARD

Failure to follow this warning could result in personal injury or death.

Ensure gasket between primary cell outlet panel and condensing heat exchanger assembly is in position to prevent leakage of combustion products.

3. Tighten all cold spot baffle screws.

Step 4 — Install New Coupling Box

1. Clean old sealant from primary cell outlet panel and condensing heat exchanger, if not done in Step 2.
2. Apply sealant releasing agent such as PAM cooking spray or equivalent (must not contain corn nor canola oil, halogenated hydrocarbons nor aromatic contents to prevent inadequate seal from occurring) to primary cell outlet panel and condensing heat exchanger surface where new coupling box sealant will mate.
3. Apply generous bead of RTV sealant (G.E. 162, G.E. 6702, or Dow-Corning 738) to coupling box flange. Sealant must not set more than 10 minutes prior to installation. (See Fig. 3.)
4. Attach coupling box using screws removed earlier, keeping coupling box movement to a minimum to avoid spreading sealant.

NOTE: Coupling box mounting holes will align in only 1 position. (See Fig. 4.)

Step 5 — Reinstall Whole Cell Panel Assembly

⚠ CAUTION

PERSONAL INJURY HAZARD

Failure to follow this caution may result in personal injury.
Whole cell panel assembly is heavy. Get help to lift and install.

1. Install whole cell panel assembly with heat exchanger, burner box, inducer assembly, J-box (if applicable), and control center (if applicable) through front of furnace.

Table 1 – Kit Usage

KIT PART NO.	UNIT											
	340MAV 350MAV 490AAV	340AAV 350AAV 353AAV	351DAS	345MAV	352AAV 352MAV	355AAV 355BAV 355CAV 355MAV	58MCA 58MXA	58MCB 58MEB 58MXB	58MSA	58MTB 58MTA PG9MXA	58MVB 58MVC 58MVP 58UVB	PG9MAA PG9MAB
330539–751	024040 036040	024040 036040	—	024040 036040	—	—	040–08 040–12	040–08 040–12	040–08 040–12	—	—	024040 036040
330539–752	024060 036060 048060	024060 036060 048060	—	024060 036060 048060	036060	042060	060–08 060–12 060–16	060–08 060–12 060–16	060–08 060–12 060–16	060–12	060–14	024060 036060 048060
330539–753	036080 048080 060080	036080 048080 060080	036080 048080 060080	036080 048080 060080	036080 048080	042080 060080	080–12 080–16 080–20	080–12 080–16 080–20	080–12 080–16 080–20	080–12 080–16	080–14 080–20	036080 048080 060080
330539–754	048100 060100	048100 060100	—	048100 060100	048100 060100	060100	100–16 100–20	100–16 100–20	100–16 100–20	100–16 100–20	100–20	048100 060100
330539–755	—	—	—	—	—	042040	—	—	—	—	040–14	—
330539–756	060120 (D and later series)	060120	—	060120	060120	060120	120–20 (130 and later series)	120–20	120–20	120–20	120–20	060120
330539–757	060140	060140	—	—	—	—	140–20	140–20	—	—	—	—
320721–765	060120 (Series A, B, and C)	—	—	—	—	—	120–20 (Series 100, 110 and 120)	—	—	—	—	—

320721 -- 765

⚠ CAUTION

UNIT AND PROPERTY DAMAGE HAZARD

Failure to follow this caution may result in property injury.
DO NOT cut or tear foil face insulation inside casing. If cuts or tears occur, repair insulation with foil tape.

- Secure whole cell panel assembly to blower shelf by installing 2 screws through blower housing and 2 screws next to blower housing.

NOTE: When reinstalling condensing heat exchanger assembly, the lower flange of the condensing heat exchanger cell rear panel must engage on the T-tabs in rear blower shelf. (See Fig. 5.)

- Install 3 screws to each side of primary cell inlet panel into cell panel supports.
- If previously removed, reinstall control center in casing flange.
- If control center is located in burner compartment or furnace, reinstall motor leads, transformer wires, door switch wires, and auxiliary limit switch wires (if present) through blower shelf and grommet.
- If control is located in blower compartment of furnace, pull wires to flame sensor, hot surface ignitor, overtemperature switch, gas valve, pressure switch(es), inducer motor, limit switch, and J-box through blower shelf.
- Install J-box.
- Reattach wires to control center or components. See wiring diagram on furnace for proper attachment.
- Reinstall condensate trap where it was previously located in furnace casing or blower shelf.
- Connect condensate trap drain tubes. See tubing diagram on furnace for proper tube location.
- Connect field drain to condensate trap.

NOTE: Ensure tubes are not kinked or pinched as this will affect operation.

- Connect vent pipe by inserting pipe into coupling, elastomeric (rubber) coupling, and then fully into inducer housing outlet. Tighten coupling clamp screw(s) to 15 in.-lb of torque.
- Connect combustion-air intake pipe to intake housing and install screw to secure. Do not use RTV unless previously used.
- Install top filler panel.
- Install gas supply pipe to gas valve using backup wrench.

NOTE: Use propane gas-resistant pipe dope to prevent gas leaks DO NOT use Teflon tape.

⚠ WARNING

FIRE AND EXPLOSION HAZARD

Failure to follow this warning could result in personal injury, death and/or property damage.
For upflow or downflow applications, gas valve knob or switch must be facing forward or tipped to the UP position.

- Connect field power supply to J-box.
- Install blower access panel.
- Turn on gas and electrical supplies to furnace.
- Check for gas leaks.

⚠ WARNING

FIRE AND EXPLOSION HAZARD

Failure to follow this warning could result in personal injury, death, and/or property damage.
Never use matches, candles, flame, or other sources of ignition to check for gas leakage. Use a soap and water solution.

- Check furnace operation through 2 cycles.
- Check for condensate leaks.
- Replace main furnace door.

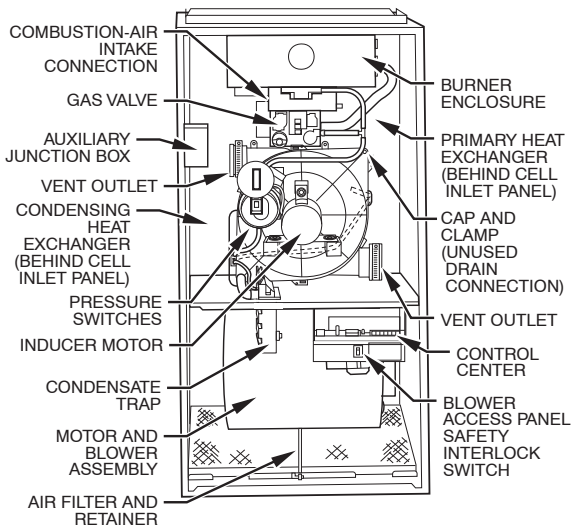

A01026

Fig. 1 - Fixed Capacity and Two-Stage, Two-Speed Models in Upflow Orientation

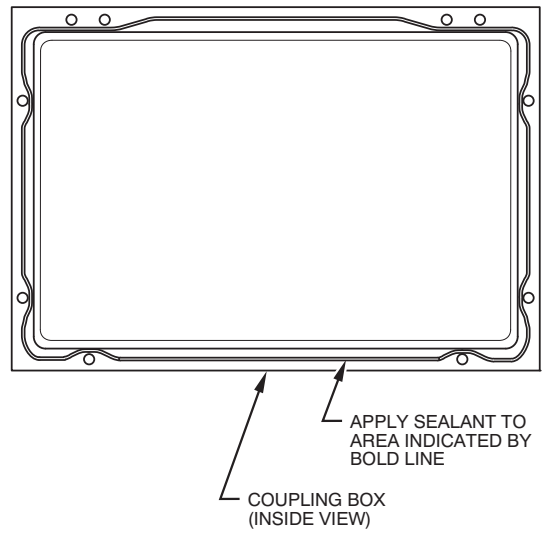

A93426

Fig. 3 - Coupling Box Sealant Application

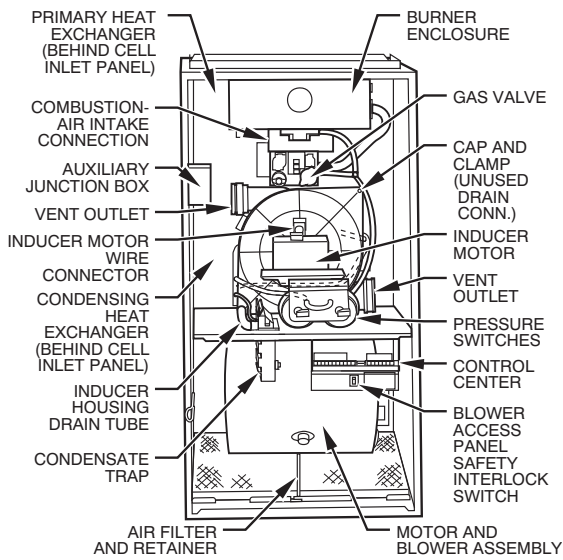

A93407

Fig. 2 - Variable-Speed Model in Upflow Orientation

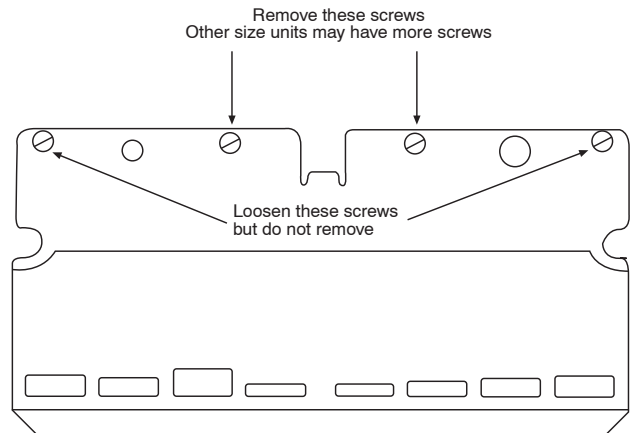

A06408

Fig. 4 - Coupling Box Mounting Holes

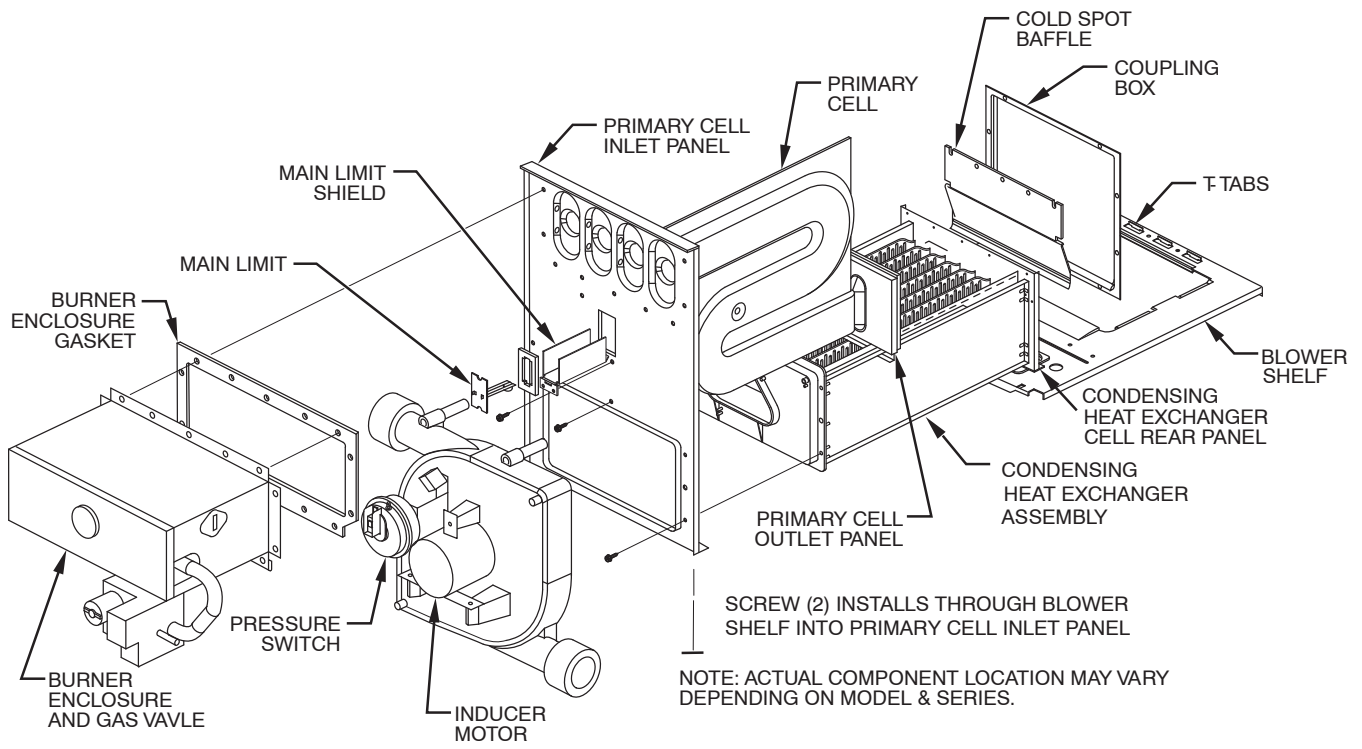

320721 -- 765

Fig. 5 - Expanded View of Heat System Components in Upflow Orientation

A07653

