

Installation Instructions

NOTE: Read the entire instruction manual before starting the installation.

SAFETY CONSIDERATIONS

Improper installation, adjustment, alteration, service, maintenance, or use can cause explosion, fire, electrical shock, or other conditions which may cause death, personal injury, or property damage. Consult a qualified installer, service agency, or your distributor or branch for information or assistance. The qualified installer or agency must use factory-authorized kits or accessories when modifying this product. Refer to the individual instructions packaged with the kits or accessories when installing.

Follow all safety codes. Wear safety glasses, protective clothing, and work gloves. Have a fire extinguisher available. Read these instructions thoroughly and follow all warnings or cautions include in literature and attached to the unit. Consult local building codes, the current editions of the National Fuel Gas Code (NFGC) NFPA 54/ANSI Z223.1 and the National Electrical Code (NEC) NFPA 70.

In Canada, refer to the current editions of the National Standards of Canada CAN/CGA-B149.1 and .2 Natural Gas and Propane Installation Codes, and Canadian Electrical Code CSA C22.1

Recognize safety information. This is the safety-alert symbol . When you see this symbol on the unit and in instructions or manuals, be alert to the potential for personal injury.

Understand the signal words **DANGER**, **WARNING**, and **CAUTION**. These words are used with the safety-alert symbol. **DANGER** identifies the most serious hazards which **will** result in severe personal injury or death. **WARNING** signifies hazards which **could** result in personal injury or death. **CAUTION** is used to identify unsafe practices which **may** result in minor personal injury or product and property damage. **NOTE** is used to highlight suggestions which **will** result in enhanced installation, reliability, or operation.

WARNING

FIRE, EXPLOSION, ELECTRICAL SHOCK HAZARD

Failure to follow this warning could result in personal injury, death and/or property damage.

Before installing or servicing unit, always turn off main electrical and gas to unit and tag with appropriate lockout. There may be more than one disconnect switch.

CAUTION

CUT HAZARD

Failure to follow this caution may result in personal injury.

Sheet metal parts may have sharp edges or burrs. Use care and wear appropriate protective clothing, safety glasses and gloves when handling parts and servicing furnaces.

WARNING

FIRE, EXPLOSION, ELECTRICAL SHOCK HAZARD

Failure to follow this warning could result in possible personal injury, death and / or property damage.

The ability to properly perform service on this equipment requires certain expertise, mechanical skills, tools, and equipment. If you do not possess these, do not attempt to perform any service on this equipment other than those procedures recommended in the User's Manual.

Table 1 – Models

MODEL	SERIES	FIGURE
340AAV / 58MCB	All	2
350AAV / 58MXB	All	2
352AAV / 58MTB	All	6
352MAV / 58MTA	All	6
353AAV / 58MEB	All	2
PG9MXA	All	6
355AAV / 58MVB	All	4
355MAV / 58MVP	All	4
355BAV / 58UVB	All	4
355CAV / 58MVC	All	7
490BAV / PG9MAB	All	2
351DAS	All	5
340MAV	A	1
350MAV	B and C, D (prior to 2496A02149 and after 1098A02241) and later series	2
490AAV	D (between 2496A02149 and 1098A02241)	3
58MCA	100	1
	100 and 120, 130 (prior to 2496A02149 and after 1098A02241) and later series	2
	130 (between 2496A02149 and 1098A02241)	3
58MXA	100	1
	110 and 120, 130 (prior to 2496A02149 and after 1098A02241), and later series	2
	130 (between 2496A02149 and 1098A02241)	3
345MAV	A (through 1098A02241)	3
PG9MAA	A (after 1098A02241), and later series	2
58MSA	100 (through 1098A02241)	3
	100 (after 1098A02241), and later series	2

324806

INTRODUCTION

This kit covers the installation of all parts necessary to replace the rubber tubing, the inducer cap, and the vent coupling. See Table 1 for models and Table 2 for kit contents.

Table 2 – Kit Contents

PART NO.	DESCRIPTION	QUANTITY
314781 – 701	Drain Tube	1
314781 – 702	Drain Tube	1
322057 – 301	Inducer / Trap Elbow	1
324157 – 402	Inducer End Cap	1
325423 – 401	Vent Coupling	1
KA69JM300	Hose Clamp	1
311162 – 430	Pressure Tubing	1
KA69UM031	Tubing Clamp	18
KA70PY191	Tee	3
KA70PS010	Tubing Connector	1

INSTALLATION INSTRUCTIONS

1. Turn off gas and electrical supplies to the unit.
2. Remove the furnace door.
3. Some tubing may need to be cut. The appropriate lengths and locations of the tubing are illustrated in the reference figures listed in Table 1.

NOTE: Pressure tubing in units may be routed differently than what is show in the diagrams. Where possible, refer to the tubing label on the unit.

4. Replace the rubber parts in the furnace that are listed in Table 2.

NOTE: Remove and replace one tube at a time. Ensure that tubing is routed in the same manner as the original pressure tubing.

⚠ WARNING

CARBON MONOXIDE POISONING AND PROPERTY DAMAGE HAZARD

Failure to follow this warning could result in personal injury, death and / or property damage.

After completing installation, vent pipe must be installed and fully seated against inducer housing internal stop. Coupling clamp screw(s) must be tightened to 15 in.-lb of torque to prevent disassembly of vent from furnace, and to prevent vent gas and condensate leakage.

5. Use the existing clamps to tighten down the new inducer end cap and the new vent coupling. Tighten clamp screws to 15 in.-lb. of torque.
6. Place pressure tubes behind casing clips (if applicable). Make sure the tubes are not kinked or pinched, as this will affect furnace operation.
7. Check tubing connections to ensure that they are secure.
8. Turn on the gas and electrical supplies.
9. Cycle test the unit with the room thermostat, to ensure proper operation.
10. Reinstall the furnace door.

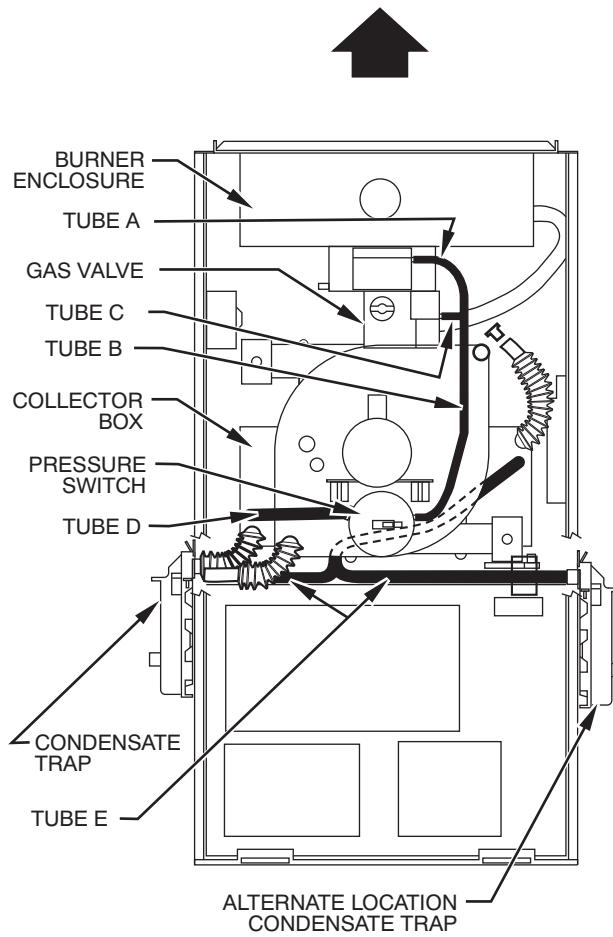

A94267

Maximum Pressure Tube Length*

UNIT SIZE	TUBE LENGTH (IN. / MM)				
	A	B	C	D	E†
040	8 / 203.2	13 / 330.2	2 / 50.8	8-3/4 / 222.3	18-1/2 / 469.9
060	8 / 203.2	13 / 330.2	2 / 50.8	8-3/4 / 222.3	18-1/2 / 469.9
080	8 / 203.2	13 / 330.2	2 / 50.8	8-3/4 / 222.3	20-1/2 / 520.7
100	8 / 203.2	13 / 330.2	2 / 50.8	8-3/4 / 222.3	20-1/2 / 520.7
120	8 / 203.2	13 / 330.2	2 / 50.8	8-3/4 / 222.3	20-1/2 / 520.7

* Shorter lengths may be required to avoid kinking tubing. This will depend upon the gas valve and pressure switch used. Refer to existing tubing lengths, if possible.

† Length will vary depending on location of furnace condensate trap.

Fig. 1 - Pressure Tube Connection Diagram for Series A Models 340MAV, 350MAV, and 490AAV and Series 100 Models of 58MCA and 58MXA 40-in. (1016 mm) Tall Multipoise Furnaces (Upflow Orientation Shown)

324806

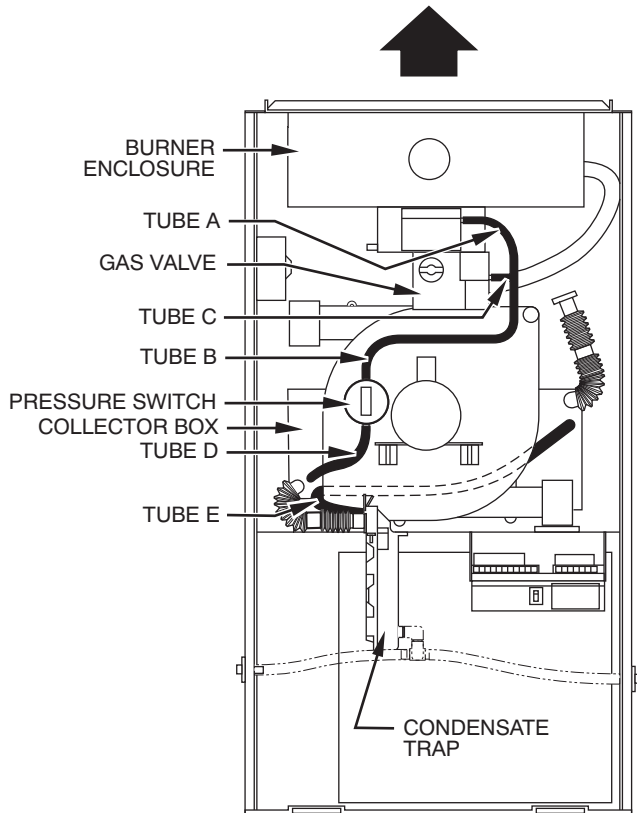

A94268

Maximum Pressure Tube Length*

UNIT SIZE	TUBE LENGTH (IN. / MM)				
	A	B	C	D	E†
040	5 / 127.0	10 / 254.0	1-1/2 / 38.1	9-1/4 / 235.0	24 / 609.6
060	5 / 127.0	10 / 254.0	1-1/2 / 38.1	9-1/4 / 235.0	24 / 609.6
080	6 / 152.4	11-1/2 / 292.1	1-1/2 / 38.1	9-1/4 / 235.0	24 / 609.6
100	6 / 152.4	11-1/2 / 292.1	1-1/2 / 38.1	9-1/4 / 235.0	24 / 609.6
120	8 / 203.2	11-1/2 / 292.1	1-1/2 / 38.1	9-1/4 / 235.0	24 / 609.6

* Shorter lengths may be required to avoid kinking tubing. This will depend upon the gas valve and pressure switch used. Refer to existing tubing lengths, if possible.

† Length will vary depending on location of furnace condensate trap.

Fig. 2 - Pressure Tube Connection Diagram in 40-in. (1016 mm) Tall Multipoise Furnaces (Upflow Orientation Shown) for Models 340MAV, 350MAV, and 490AAV Series B, C, D (Prior to 2496A02149 and after 1098A02241) and later series; Models 58MCA and 58MXA Series 110, 120, 130 (prior to 2496A02149 and after 1098A02241) and later series; Model 345MAV Series A (after 1098A02241) and later series; Model 58MSA Series 100 (after 1098A02241) and later series; Models PG9MAA Series A (after 1098A02241) and later series; Model PG9MAB Series A and later series; Models 340AAV and 350AAV Series A and later series; Models 58MCB and 58MXB Series 100 and later series Models 353AAV Models 58MEB

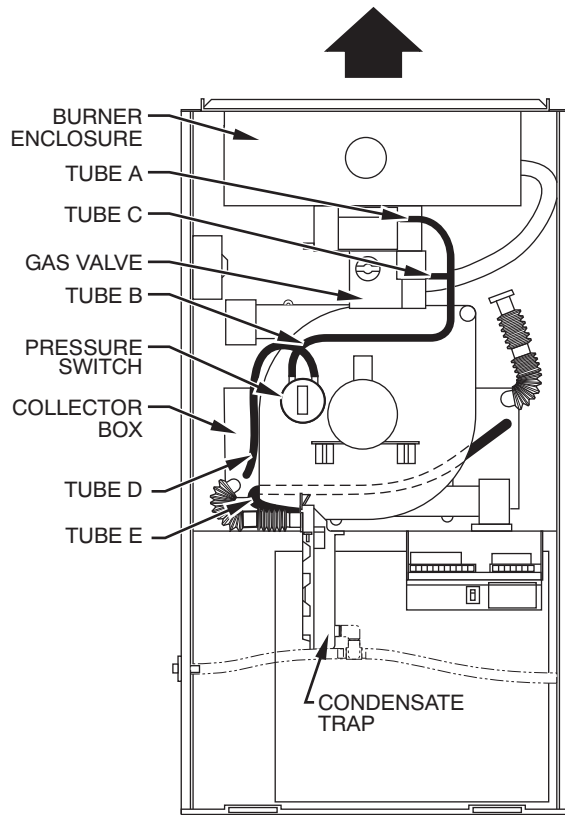

A96252

Maximum Pressure Tube Length*

UNIT SIZE	TUBE LENGTH (IN. / MM)				
	A	B	C	D	E†
040	5 / 127.0	10 / 254.0	1-1/2 / 38.1	15-1/4 / 387.4	22 / 558.8
060	5 / 127.0	10 / 254.0	1-1/2 / 38.1	15-1/4 / 387.4	22 / 558.8
080	6 / 152.4	11-1/2 / 292.1	1-1/2 / 38.1	15-1/4 / 387.4	22 / 558.8
100	6 / 152.4	11-1/2 / 292.1	1-1/2 / 38.1	15-1/4 / 387.4	22 / 558.8
120	8 / 203.2	11-1/2 / 292.1	1-1/2 / 38.1	15-1/4 / 387.4	22 / 558.8
140	8 / 203.2	11-1/2 / 292.1	1-1/2 / 38.1	15-1/4 / 387.4	22 / 558.8

* Shorter lengths may be required to avoid kinking tubing. This will depend upon the gas valve and pressure switch used. Refer to existing tubing lengths, if possible.

† Length will vary depending on location of furnace condensate trap.

Fig. 3 - Pressure Tube Connection Diagram (Upflow Orientation Shown) for Models 340MAV, 345MAV, 350MAV, 58MCA, 58MSA, 58MXA, PG9MAA and 490AAV (between 2496A02149 and 1098A02241)

324806

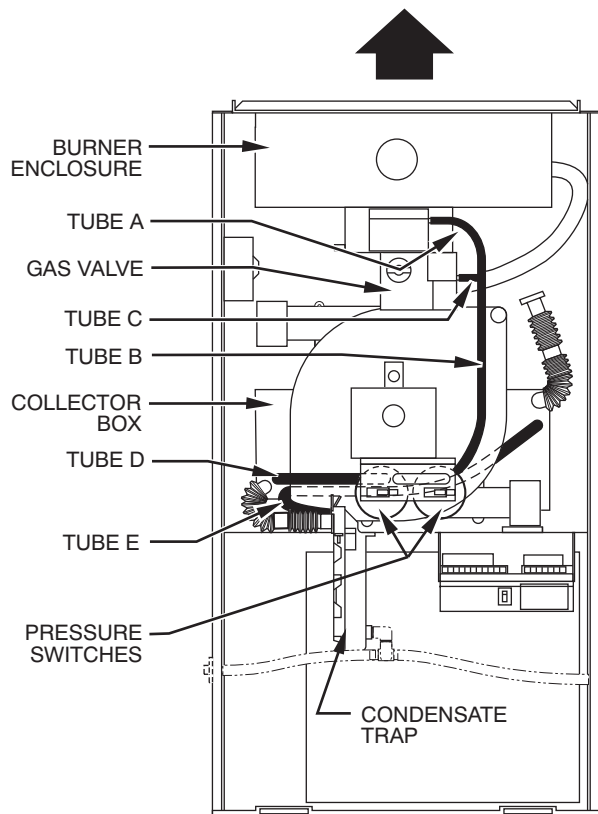

A94269

Maximum Pressure Tube Length*

UNIT SIZE	TUBE LENGTH (IN. / MM)				
	A	B	C	D	E†
040	6-1/2 / 165.1	13-1/2 / 342.9	3 / 76.2	10-1/2 / 266.7	24 / 609.6
060	6-1/2 / 165.1	13-1/2 / 342.9	3 / 76.2	10-1/2 / 266.7	24 / 609.6
080	6-1/2 / 165.1	13-1/2 / 342.9	3 / 76.2	10-1/2 / 266.7	24 / 609.6
100	6-1/2 / 165.1	13-1/2 / 342.9	3 / 76.2	10-1/2 / 266.7	24 / 609.6
120	8 / 203.2	13-1/2 / 342.9	1-1/2 / 38.1	10-1/2 / 266.7	24 / 609.6

* Shorter lengths may be required to avoid kinking tubing. This will depend upon the gas valve and pressure switch used. Refer to existing tubing lengths, if possible.

† Length will vary depending on location of furnace condensate trap.

Fig. 4 - Pressure Tube Connection Diagram in a 40-in. (1016 mm) Tall Multipoise Furnace (Upflow Orientation Shown) for Models 355MAV, 355AAV, 355BAV, 58MVP, 58MVB and 58UVB

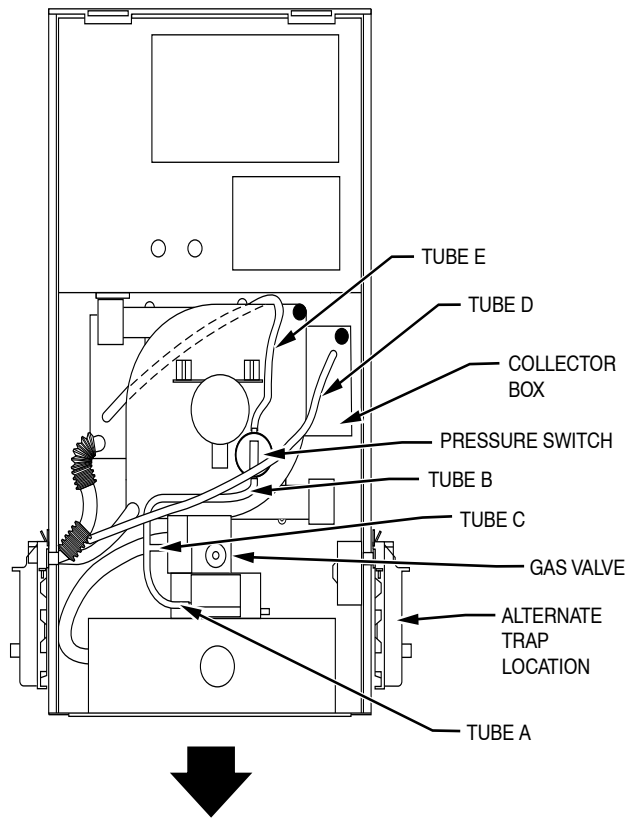

Maximum Pressure Tube Length*

A99058

UNIT SIZE	TUBE LENGTH (IN. / MM)				
	A	B	C	D	E
080	6 / 152.4	11-1/2 / 292.1	1-1/2 / 38.1	26 / 660.4	24 / 609.6

* Shorter lengths may be required to avoid kinking tubing. This will depend upon the gas valve and pressure switch used. Refer to existing tubing lengths, if possible.

Fig. 5 - Pressure Tube Connection Diagram for Model 351DAS 40-in. (1016 mm) Tall Downflow Furnaces

324806

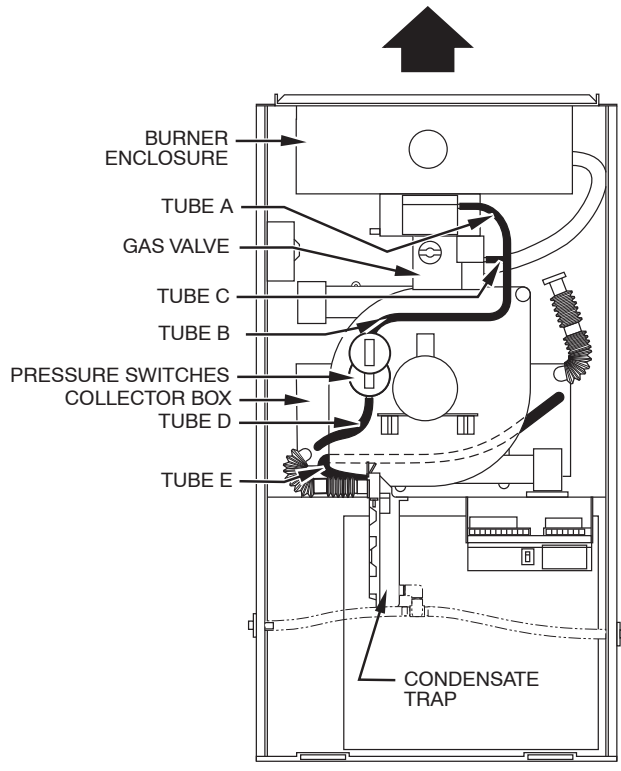

A01079

Maximum Pressure Tube Length*

UNIT SIZE	TUBE LENGTH (IN. / MM)				
	A	B	C	D	E†
060	5 / 127.0	10 / 254.0	1-1/2 / 38.1	6 / 152.4	24 / 609.6
080	6 / 152.4	11-1/2 / 292.1	1-1/2 / 38.1	6 / 152.4	24 / 609.6
100	6 / 152.4	11-1/2 / 292.1	1-1/2 / 38.1	6 / 152.4	24 / 609.6
120	8 / 203.2	11-1/2 / 292.1	1-1/2 / 38.1	6 / 152.4	24 / 609.6

* Shorter lengths may be required to avoid kinking tubing. This will depend upon the gas valve and pressure switch used. Refer to existing tubing lengths, if possible.

Fig. 6 - Pressure Tube Connection Diagram in a 40-in. (1016 mm) Tall Multipoise Furnace (Upflow Orientation Shown) for Models 352MAV, 352AAV, 58MTA, 58MTB and PG9MXA

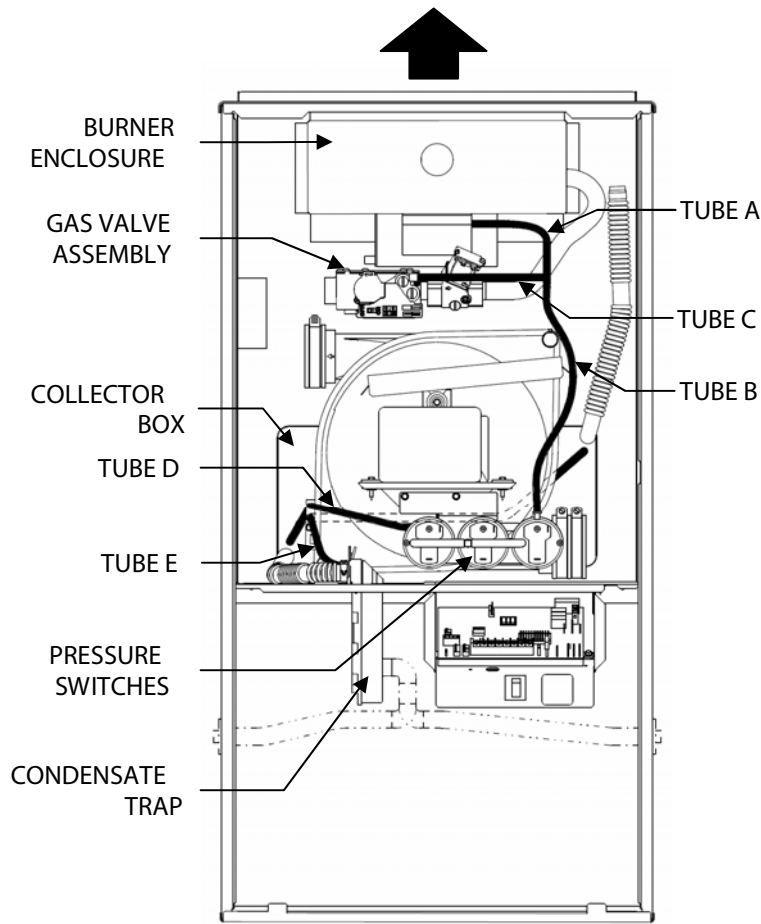

324806

A07660

Maximum Pressure Tube Length*

UNIT SIZE	TUBE LENGTH (IN. / MM)				
	A	B	C	D	E†
060	6 / 152.4	11-1/4 / 285.8	6-3/4 / 171.5	10-1/2 / 266.7	24 / 609.6
080	6 / 152.4	11-1/4 / 285.8	6-3/4 / 171.5	10-1/2 / 266.7	24 / 609.6
100	6 / 152.4	11-1/4 / 285.8	6-3/4 / 171.5	10-1/2 / 266.7	24 / 609.6
120	6-1/2 / 165.1	11-1/4 / 285.8	4-1/2 / 114.3	10-1/2 / 266.7	24 / 609.6

* Shorter lengths may be required to avoid kinking tubing. This will depend upon the gas valve and pressure switch used. Refer to existing tubing lengths, if possible.

† Length will vary depending on location of furnace condensate trap.

Fig. 7 - Pressure Tube Connection Diagram for Models 355CAV and 58MVC 40-in. (1016 mm) Tall Multipoise Furnaces (Upflow Orientation Shown)

324806