

Installation Instructions

NOTE: Read the entire instruction manual before starting the installation.

SAFETY CONSIDERATIONS

Improper installation, adjustment, alteration, service, maintenance, or use can cause explosion, fire, electrical shock, or other conditions which may cause death, personal injury, or property damage. Consult a qualified installer, service agency, or your distributor or branch for information or assistance. The qualified installer or agency must use factory-authorized kits or accessories when modifying this product. Refer to the individual instructions packaged with the kits or accessories when installing. Follow all safety codes. Wear safety glasses, protective clothing, and work gloves. Have a fire extinguisher available. Read these instructions thoroughly and follow all warnings or cautions include in literature and attached to the unit. Consult local building codes, the current editions of the National Fuel Gas Code (NFGC) NFPA 54/ANSI Z223.1 and the National Electrical Code (NEC) NFPA 70.

In Canada, refer to the current editions of the National Standards of Canada CAN/CGA-B149.1 and .2 Natural Gas and Propane Installation Codes, and Canadian Electrical Code CSA C22.1

Recognize safety information. This is the safety-alert symbol . When you see this symbol on the unit and in instructions or manuals, be alert to the potential for personal injury.

Understand the signal words **DANGER**, **WARNING**, and **CAUTION**. These words are used with the safety-alert symbol. **DANGER** identifies the most serious hazards which **will** result in severe personal injury or death. **WARNING** signifies hazards which **could** result in personal injury or death. **CAUTION** is used to identify unsafe practices which **may** result in minor personal injury or product and property damage. **NOTE** is used to highlight suggestions which **will** result in enhanced installation, reliability, or operation.

WARNING

FIRE, EXPLOSION AND ELECTRICAL SHOCK HAZARD

Failure to follow this warning could result in personal injury, death and/or property damage.

Before installing or servicing system, always turn off main electrical and gas to unit and tag with appropriate lockout. There may be more than one disconnect switch.

CAUTION

UNIT DAMAGE HAZARD

Failure to follow this caution may cause improper and dangerous operation

Label all wires prior to disconnection when servicing controls.

CAUTION

UNIT DAMAGE HAZARD

Failure to follow this caution may cause result in personal injury.

Sheet metal parts may have sharp edges or burrs. Use care and wear appropriate protective clothing and gloves when handling parts.

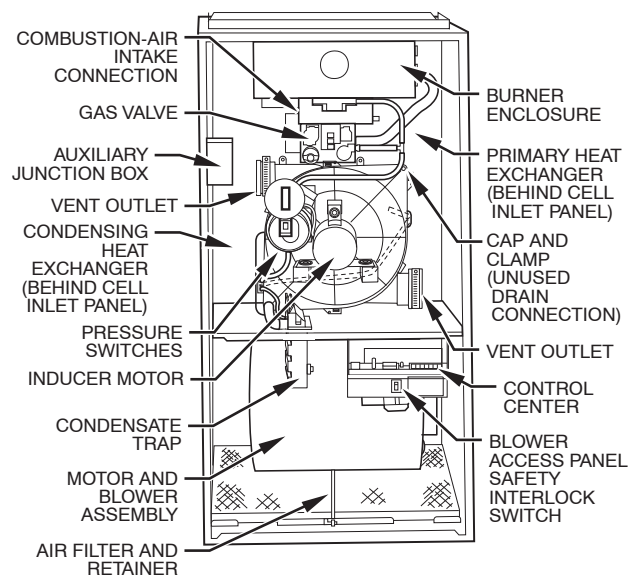

Fig. 1 - Fixed and Two-Stage Models

A01026

INTRODUCTION

This instruction covers installation of the Condensing Heat Exchanger Kit in 40-in. (1016 mm) tall condensing furnaces. Refer to Table 1 for correct kit usage for your model furnace.

NOTE: A releasing agent such as PAM cooking spray or equivalent (must not contain corn or canola oil, halogenated hydrocarbons nor aromatic contents to prevent inadequate seal from occurring) and RTV sealant (G.E. 162, G.E. 6702, or Dow-Corning 738) are needed before starting installation. DO NOT substitute any other type of RTV sealant. G.E. 162 (P771-9003) is available through RCD in 3-oz. tubes.

DESCRIPTION AND USAGE

Use this Condensing Heat Exchanger Kit to replace a failed condensing heat exchanger.

This Condensing Heat Exchanger Kit contains the following items:

Condensing heat exchanger assembly (includes collector box)	1
Outlet cell panel gasket	1
Outlet cell panel screw (8A x 1/2-in. (12.5 mm))	7 max
Installation Instructions	1

INSTALLATION

Step 1 — Remove Whole Cell Panel Assembly

See Fig. 1 and 2 for furnace component locations. See Fig. 3 for expanded view of heating system components.

NOTE: Actual component location may vary depending on model and series.

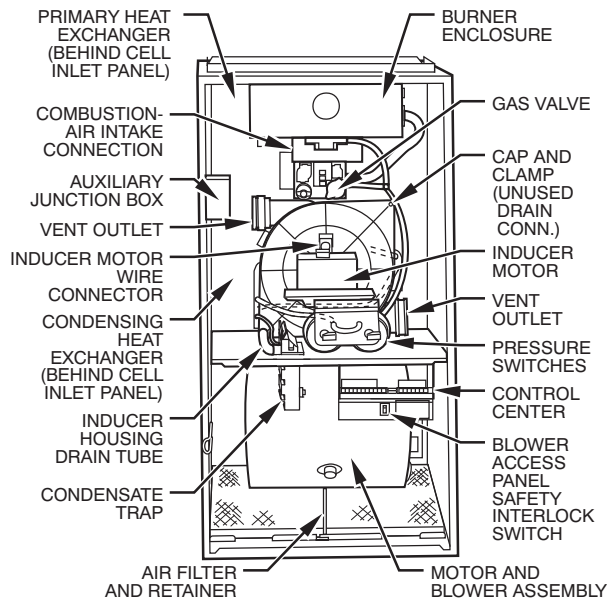

A93407

Fig. 2 - Step Modulating and Variable Capacity Models

1. Turn off gas and electrical supplies to furnace.
2. Remove main furnace door.
3. Remove blower access panel.
4. Disconnect field power supply wires from J-box.
5. Remove two screws securing J-box.
6. Remove two screws securing top filler panel and rotate panel upwards to remove or allow the heat exchanger to be removed from front of furnace.

7. Disconnect combustion-air intake pipe from intake housing and move pipe out of furnace casing.
8. Disconnect gas supply pipe from gas valve using backup-wrench.
9. Disconnect vent pipe from inducer housing by loosening coupling clamp on inducer outlet. If coupling has 2 clamps, loosen clamp on vent pipe side. Move pipe out of furnace casing.
10. If control center is located in burner compartment of furnace, remove blower motor leads, transformer wires, door switch wires, and auxiliary limit switch wires (if present) from control center and pull wires through blower shelf.
11. If control center is located in blower compartment of furnace, disconnect wires from flame sensor, hot surface igniter, overtemperature switch, gas valve, pressure switch(es), inducer motor, limit switch, and J-box, then pull wires through blower shelf.
12. Remove two screws securing blower to blower shelf (four screws on 120 and 140 sizes).
13. Remove two screws adjacent to blower mounting screws that secure blower shelf to cell panel.
14. Remove three screws from each side of cell panel.
15. If control center is located in burner compartment of furnace, remove control center by removing screw and pressing tabs inward.
16. If control center was removed from furnace casing, secure control center (and J-box) to manifold for removal purposes only.
17. Disconnect drain tubes and relief port tube from condensate trap.
18. Disconnect field drain connections from condensate trap.
19. Remove condensate trap from furnace casing or blower shelf.
20. Remove whole cell panel assembly with heat exchanger, burner box, inducer assembly, J-box (if applicable), and control center (if applicable) attached through front of furnace.

CAUTION

PERSONAL INJURY HAZARD

Failure to follow this caution may result in personal injury. Whole cell panel assembly is heavy. Get help to remove and lift assembly.

Step 2 — Remove Inducer Assembly

1. If not previously disconnected, disconnect inducer motor wire connector at quick-connect.
2. If not previously disconnected, disconnect pressure switch wires.
3. If not previously disconnected, remove wires from gas valve. Note location for reassembly.
4. Remove burner box cover.
5. Remove screws securing manifold to burner box.
6. Remove manifold, orifices, and gas valve as one assembly.
7. Remove collector box pressure switch tube from pressure switch.
8. Remove four screws attaching inducer housing to cell panel.

NOTE: Inducer assembly comprised of inducer housing, inducer motor, and pressure switch(es) should be removed as one assembly.

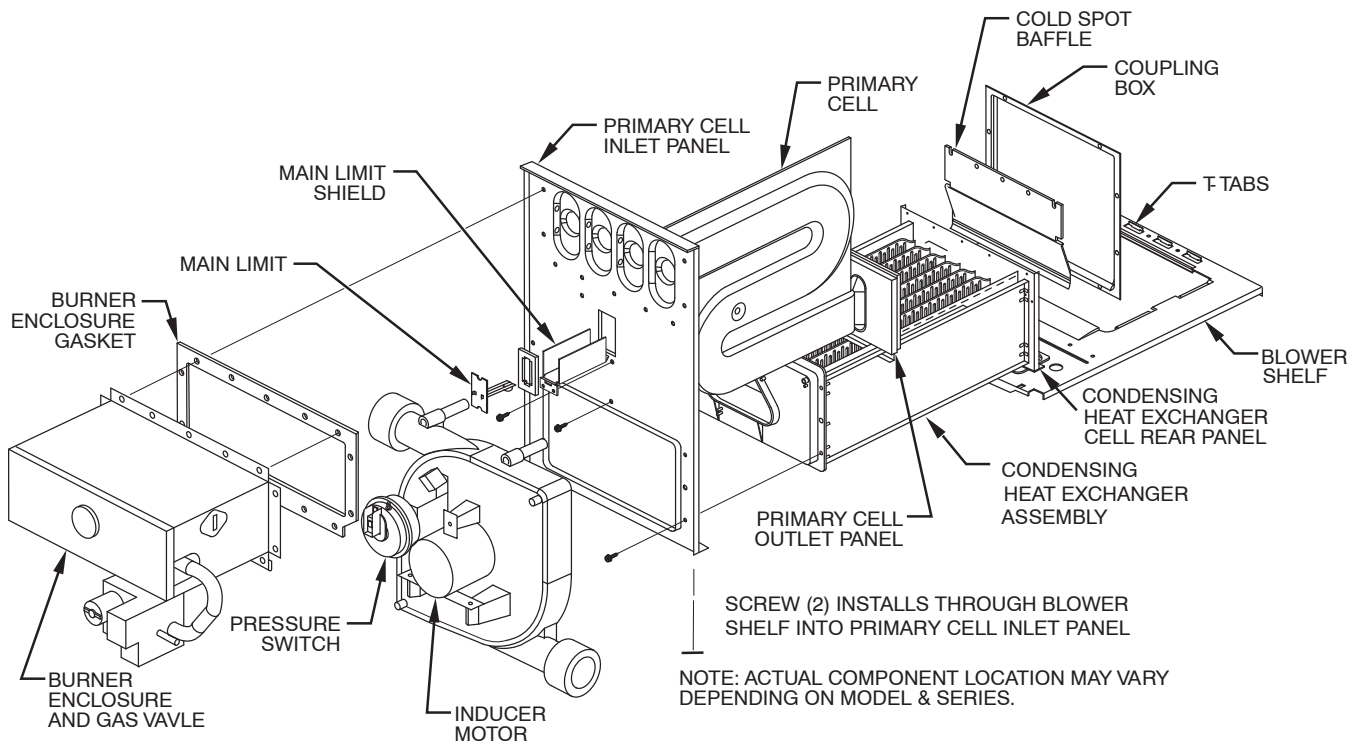

Fig. 3 - Expanded View of Heat System Components in Upflow Orientation

A07653

Step 3 — Remove Coupling Box

1. Remove screws securing coupling box to primary cell outlet panel and condensing heat exchanger.
2. Break seal between top flange of coupling box and cell panel using screwdriver blade.
3. Remove coupling box.

Step 4 — Remove Cold Spot Baffle

1. Remove all screws securing cold spot baffle to primary cell outlet panel and condensing heat exchanger.
2. Remove cold spot baffle.

Step 5 — Remove Old Condensing Heat Exchanger Assembly

1. Remove screws attaching primary cell inlet panel to condensing heat exchanger assembly.
2. Slide condensing heat exchanger assembly away from cell panels.
3. Remove and discard primary cell outlet panel gasket.

Step 6 — Install New Condensing Heat Exchanger Assembly

1. Remove and discard four shipping screws as shown in Fig. 4.
2. Remove and discard installer labels as shown in Fig. 4.
3. The block-off plates attached to the replacement condensing heat exchanger are for use on the 355CAV and 58MVC furnace only. Different block-off plates are required for 355BAV and 58UVB models. Refer to the steps below for the appropriate model being serviced.

For 355CAV and 58MVC furnaces: Do not remove block-off plates. Proceed to Step 4.

For 355BAV and 58UVB furnaces:

- Remove the block-off plates from the replacement condensing heat exchanger.

- Remove the block-off plates from the existing heat ex-

changer being replaced.

- Install the block-off plates from the existing condensing heat exchanger on the new condensing heat exchanger. Proceed to Step 4.

ON ALL OTHER MODELS: Remove the two block-off plates that are partially covering the openings at the bottom of the replacement condensing heat exchanger rear panel. Proceed to Step 4.

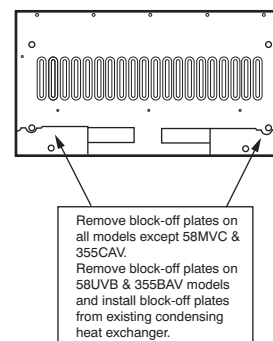

Fig. 4 - Block-off Plates

A07652

4. Slide condensing heat exchanger assembly into primary cell inlet panel opening.
5. Position gasket between primary cell outlet panel and condensing heat exchanger assembly flange.
6. Attach condensing heat exchanger assembly to primary cell inlet panel.
7. Attach condensing heat exchanger assembly to primary cell outlet panel by starting 2 outside screws using new screws supplied in kit.

Table 1 – Kit Usage

KIT PART NO.	UNIT									
	340AAV 340MAV 350AAV 350MAV 353AAV 490AAV	351DAS	345MAV	352AAV 352MAV PG9MXA	355AAV 355BAV 355MAV 355CAV	58MCA 58MCB 58MEB 58MXA 58MXB	58MSA	58MTA 58MTB	58MVB 58MVP 58UVB 58MVC	PG9MAA PG9MAB
330540-755	024040 036040	—	024040 036040	—	—	040-08 040-12	040-08 040-12	—	—	024040 036040
330540-755	024060 036060 048060	—	024060 036060 048060	036060	042060	060-08 060-12 060-16	060-08 060-12 060-16	060-12	060-14	024060 036060 048060
330540-760	036080 048080 060080	036080 048060 060080	036080 048080 060080	036080 048080	042080 060080	080-12 080-16 080-20	080-12 080-16 080-20	080-12 080-16	080-14 080-20	036080 048080 060080
330540-761	048100 060100	—	048100 060100	048100 060100	060100	100-16 100-20	100-16 100-20	100-16 100-20	100-20	048100 060100
330540-758	060120 060140	—	060120	060120	060120	120-20 140-20	120-20	120-20	120-20	060120 060140
330540-758	—	—	—	—	042040	—	—	—	040-14	—

334357

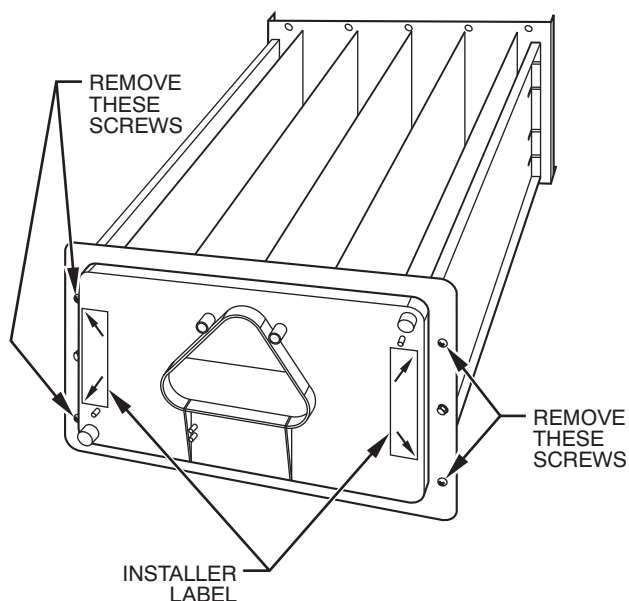

A94150

Fig. 5 - Condensing Heat Exchanger Assembly as Shipped

Step 7 — Reinstall Cold Spot Baffle

1. Position cold spot baffle so positioning tab is facing away from condensing heat exchanger. Slide cold spot baffle under loose end screws.
2. Start screws that secure cold spot baffle to primary cell outlet panel. Use 1/2-in. (12.5 mm) screws provided in kit.
3. Tighten all cold spot baffle screws.

Step 8 — Reinstall Coupling Box

1. Clean old sealant from condensing heat exchanger assembly.
2. Apply sealant releasing agent such as PAM cooking spray or equivalent (must not contain corn or canola oil, halogenated hydrocarbons nor aromatic contents to prevent inadequate seal) to primary cell outlet panel and condensing heat exchanger surface where new coupling box sealant will mate. (See Fig. 3.)

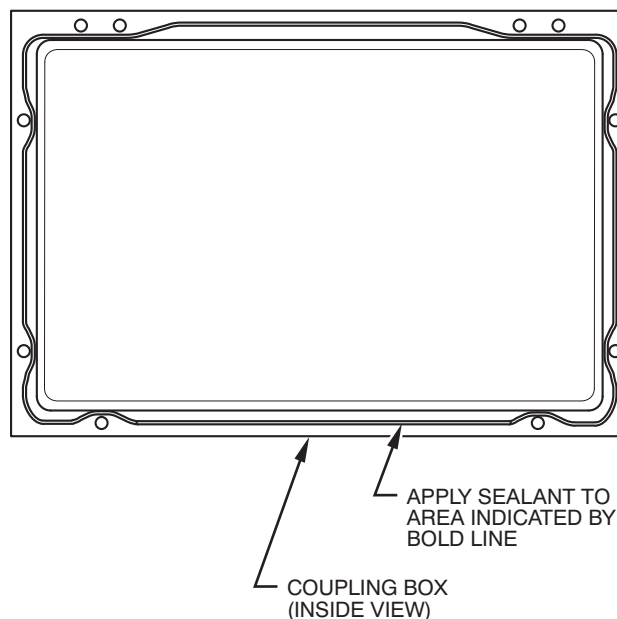

A93426

Fig. 6 - Coupling Box Sealant Application

3. Apply generous bead of RTV sealant (G.E. 162, G.E. 6702, or Dow-Corning 738) to coupling box flange. Sealant must not set more than 10 minutes prior to installation. (See Fig. 6.)
4. Attach coupling box using screws removed earlier, keeping coupling box movement to a minimum to avoid spreading sealant.

NOTE: Coupling box mounting holes will only align in 1 position. (See Fig. 3.)

▲ WARNING

CARBON MONOXIDE POISONING HAZARD

Failure to follow this warning could result in personal injury or death.

Ensure gasket between primary cell outlet panel and condensing heat exchanger assembly is in position to prevent leakage of combustion products.

Step 9 — Reinstall Whole Cell Panel Assembly

1. Install whole cell panel assembly with heat exchanger, burner box, inducer assembly, J-box (if applicable), and control center (if applicable) through front of furnace.



CAUTION

PERSONAL INJURY HAZARD

Failure to follow this caution may result in personal injury. Whole cell panel assembly is heavy. Get help to remove and lift assembly.



CAUTION

UNIT AND PROPERTY DAMAGE HAZARD

Failure to follow this caution may result in property damage. DO NOT cut or tear foil face insulation inside casing. If cuts or tears occur, repair insulation with foil tape.

2. Secure whole cell panel assembly to blower shelf by installing two screws through blower housing (four screws on 120 and 140 sizes) and two screws adjacent to blower housing.
3. Install three screws to each side of inlet cell panel and into cell panel supports.
4. If previously removed, reinstall control center in casing flange.
5. If control center is located in burner compartment or furnace, reinstall blower motor leads, transformer wires, door switch wires, and auxiliary limit switch wires (if present) through blower shelf and grommet.
6. If control is located in blower compartment of furnace, pull wires to flame sensor, hot surface igniter, overtemperature switch, gas valve, pressure switch(es), inducer motor, limit switch, and J-box through blower shelf.
7. Reinstall manifold assembly with gas valve to burner box. Replace mounting screws.
8. Replace burner box cover.
9. Install J-box.
10. Reattach wires to control center or components. See wiring diagram on furnace for proper attachment.
11. Reinstall condensate trap in furnace casing or blower shelf.
12. Reconnect condensate trap drain tubes. See tubing diagram on furnace for proper tube location.
13. Connect field drain to condensate trap.

NOTE: When re-installing condensing heat exchanger assembly, the lower flange of the condensing heat exchanger cell rear panel must engage on the T-tabs in rear blower shelf. (See Fig. 3.)

NOTE: Ensure tubes are not kinked or pinched, as this will affect operation.

14. Connect vent pipe by inserting pipe through the elastomeric (rubber) coupling and then fully into inducer housing outlet. Tighten coupling clamp screw(s) to 15 in.-lb of torque.
15. Connect combustion-air intake pipe to intake housing and install screw to secure. Do not use RTV unless previously used.
16. Install top filler panel.
17. Install gas supply pipe to gas valve using backup wrench.

NOTE: Use propane gas resistant pipe dope to prevent gas leaks. DO NOT use Teflon tape.



WARNING

FIRE AND EXPLOSION HAZARD

Failure to follow this warning could result in personal injury, death and/or property damage.

For upflow or downflow applications, gas valve knob or switch must be facing forward or tipped to the UP position.

18. Connect field power supply to J-box.
19. Install blower access panel.
20. Turn on gas and electrical supplies to furnace.
21. Check for gas leaks.



WARNING

EXPLOSION AND FIRE HAZARD

Failure to follow this warning could result in personal injury, death, and/or property damage.

Never test for gas leaks with an open flame. Use a commercially available soap solution made specifically for the detection of leaks to check all connections.

22. Check furnace operation through two cycles.
23. Check for condensate leaks.
24. Replace main furnace door.

334357