

Installation Instructions

TABLE OF CONTENTS

PACKAGE USAGE 1
 GENERAL 1
 SAFETY CONSIDERATIONS 1
 PACKAGE CONTENTS 2
 INSTALLATION 3
 CONFIGURATION 6
 TROUBLESHOOTING 12

PACKAGE USAGE

UNIT	PART NUMBER
48/50HJ020,024 48/50PG20,24 551A/581A210,240	CRECOMZR046A00
48/50HJ028 48/50PG28 551A/581A300	CRECOMZR047A00

GENERAL

IMPORTANT: Read these instructions completely before attempting to install the accessory economizer.

The accessory economizer package uses solid-state controls to sequence mechanical cooling with cool outdoor air (free cooling) to satisfy the cooling load and minimize energy consumption. Free cooling can be used alone or in conjunction with mechanical cooling.

The standard economizer uses an outdoor-air temperature sensor to sense outdoor-air temperature. The economizer will provide cooling when the outdoor temperature is suitable and if there is a cooling demand. In addition, if an outdoor enthalpy sensor accessory has been installed, then the enthalpy reading must also be “low” before economizer cooling can occur.

When free cooling is available, the economizer sequences free cooling with mechanical cooling to maintain comfort in the space. When free cooling is not available, the economizer modulates to an adjustable minimum position to maintain a supply of fresh air entering the building.

Optional barometric relief dampers provide natural building pressurization control when the building pressure rises high enough to overcome the weight of the damper. An optional power exhaust system is available for jobs requiring greater relief.

SAFETY CONSIDERATIONS

Installation and servicing of air-conditioning equipment can be hazardous due to system pressure and electrical components. Only trained and qualified service personnel should install, repair, or service air-conditioning equipment.

Untrained personnel can perform basic maintenance functions of cleaning coils and filters and replacing filters. All other operations should be performed by trained service personnel. When working on air-conditioning equipment, observe precautions in the literature, tags and labels attached to the unit, and other safety precautions that may apply.

Follow all safety codes. Wear safety glasses and work gloves. Use quenching cloth for brazing operations. Have fire extinguisher available. Read these instructions thoroughly and follow all warnings or cautions attached to the unit. Consult local building codes and National Electrical Code (NEC) for special requirements.

Recognize safety information. This is the safety-alert symbol . When you see this symbol on the unit and in instruction manuals, be alert to the potential for personal injury.

Understand the signal words DANGER, WARNING, CAUTION. These words are used with the safety-alert symbol. DANGER identifies the most serious hazards which **will** result in severe personal injury or death. WARNING signifies hazards which **could** result in personal injury or death. CAUTION is used to identify unsafe practices which **may** result in minor personal injury or product and property damage. NOTE is used to highlight suggestions which **will** result in enhanced installation, reliability, or operation.

IMPORTANT: Do not adjust the economizer damper assembly. The actuator and damper have been pre-set and adjusted for proper operation.

PACKAGE CONTENTS

PART NO.	PART NO.	QTY	CONTENTS
CRECOMZR046A00	50TG500495	1	Damper Assy
	50TG403161	1	Blockoff Panel (Insulated)
	50TG500303	1	Lower Hood Top Panel
	50TG500301	1	Hood Side
	50TG500302	1	Hood Side
	50TG501090	2	Side Filter Guide
	50TG500304	1	Upper Hood Top Panel
	50TG500306	1	Filter Bracket
	50TG501091	1	Filter Retainer Track
	KH03DU350	3	Filter
	HH63AW001	1	Economizer Controller
	AL56AU130	2	No. 6 Screw x 1-in.
	AL48AM307	10	1/4-in. Screw x 5/8-in.
	AL31AZ308	25	1/4-in. Screw x 3/4-in.
	AS41BZ133	3	Speed Nut
	HY76TB110	9	Wire Tie (snap-in)
	HY76TB125	5	Wire Tie
	50TG404553	1	Harness Assy
	—	1	Seal Strip
	HH79NZ002	1	Supply Air Temperature Sensor (3 K ohm)
	HH18HA286	1	Low Temperature Compressor Lockout Switch
	50TG504544	1	Low Temperature Compressor Lockout Bracket
	HH57AC074	1	Outdoor Temperature Sensor
	AL56AU126	4	No. 6 Screw x 1/2-in.
	99WH6971XC214218	2	Wire
	HY93NH069	1	Snap Bushing
	HY76TB035	1	Wire Tie Screw
	AL48AM217	3	No. 10 Screw x 5/8-in.

PART NO.	PART NO.	QTY	CONTENTS
CRECOMZR047A00	50TG500496	1	Damper Assy
	50TG403163	1	Blockoff Panel (Insulated)
	50TG500303	1	Lower Hood Top Panel
	50TG500301	1	Hood Side
	50TG500302	1	Hood Side
	50TG501090	2	Side Filter Guide
	50TG500304	1	Upper Hood Top Panel
	50TG500306	1	Filter Bracket
	50TG501091	1	Filter Retainer Track
	KH03DU350	3	Filter
	HH63AW001	1	Economizer Controller
	AL56AU130	2	No. 6 Screw x 1-in.
	AL48AM307	10	1/4-in. Screw x 5/8-in.
	AL31AZ308	22	1/4-in. Screw x 3/4-in.
	AS41BZ133	3	Speed Nut
	HY76TB110	9	Wire Tie (snap-in)
	HY76TB125	5	Wire Tie
	50TG404553	1	Harness Assy
	—	1	Seal Strip
	HH79NZ002	1	Supply Air Temperature Sensor (3 K ohm)
	HH18HA286	1	Low Temperature Compressor Lockout Switch
	50TG504544	1	Low Temperature Compressor Lockout Bracket
	HH57AC074	1	Outdoor Temperature Sensor
	AL56AU126	4	No. 6 Screw x 1/2-in.
	99WH6971XC214218	2	Wire
	HY93NH069	1	Snap Bushing
	HY76TB035	1	Wire Tie Screw
	AL48AM217	3	No. 10 Screw x 5/8-in.

NOTE: If unit is already equipped with an outdoor air hood, hood parts in the accessory will not be used and may be discarded.

CRECOMZR

INSTALLATION

⚠ WARNING

ELECTRICAL OPERATION HAZARD

Failure to follow this warning could result in personal injury or death.

Before installing or servicing unit, always turn off all power to unit. There may be more than 1 disconnect switch.

1. Prepare the unit for installation:
 - a. For units with two-position damper installed, remove the outdoor air hood. (See Fig. 1.) Unplug the two-position damper and remove the assembly from the outdoor air opening.
 - b. For units with manual damper installed, remove manual damper and filter.
 - c. For units with no outdoor air option installed, remove the outdoor air intake cover. (See Fig. 2.)

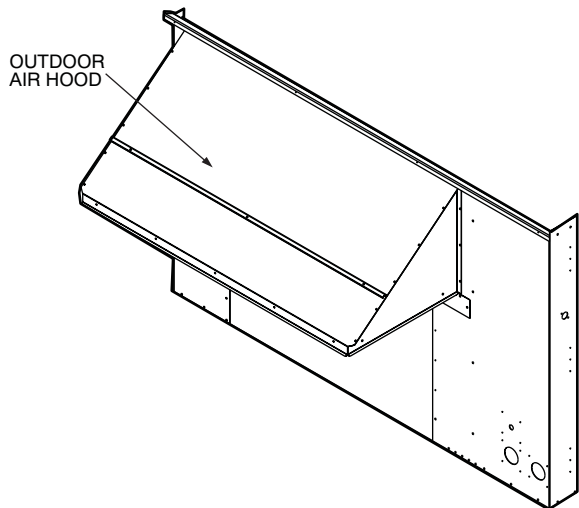

C06327

Fig. 1 – Outdoor Air Hood

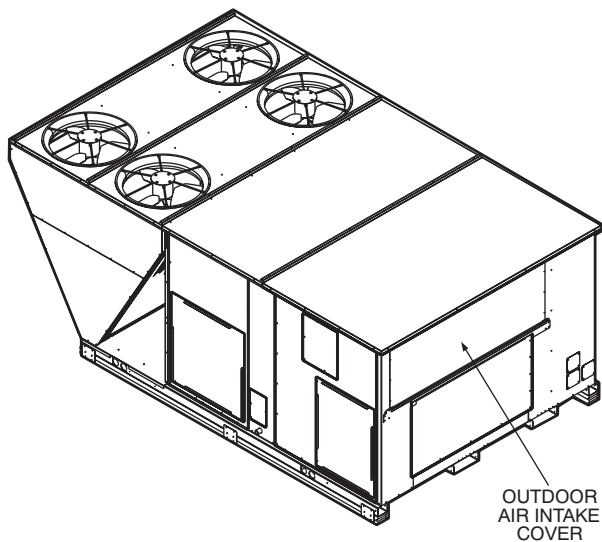

C06328

Fig. 2 – Outdoor Air Intake Cover

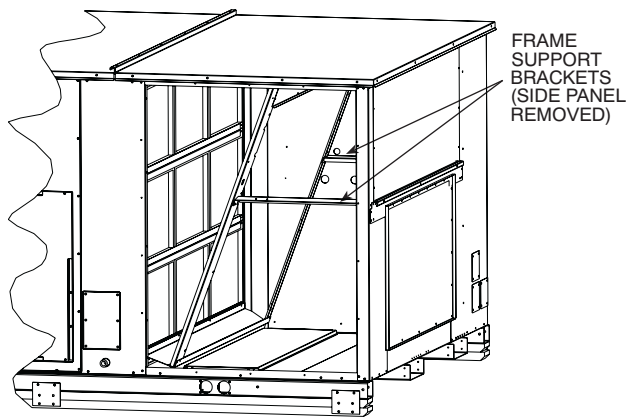

C06329

Fig. 3 – Frame Support Brackets
(Side Panel Removed)

2. Remove the side panel on the return end of the unit to expose the return section of the unit. Save the screws for use later when replacing the panel. The inside of the unit will contain a frame for installing the economizer as shown in Fig. 3.

⚠ CAUTION

UNIT DAMAGE HAZARD

Failure to follow this caution may result in equipment or property damage.

Cover the duct opening as a precaution so objects cannot fall into the return duct opening.

3. Remove the frame support brackets from both sides of the frame inside the unit. (See Fig. 3.) Save the screws for use later.
4. Uncrate the economizer assembly. Position the damper assembly so that it will rest on the angle bracket support at the bottom of the economizer frame inside the unit. Slide the economizer into the unit. (See Fig. 4.) Secure the damper assembly to the frame using the $\frac{1}{4}$ -in. x $\frac{5}{8}$ -in. screws provided.
5. Open the hinged control box compartment on the unit and remove the control box cover. Save the screws for use later. Be sure not to place sharp objects on any surface that could be damaged.
6. Install the economizer controller (P/N HH63AW001) into the control box using the two no. 6 x 1-in. screws provided. The economizer controller will mount into the pre-drilled holes on the back of the control box as shown in Fig. 5.
7. Connect the wiring harness (P/N 50TG404553) to the EconoMiSer IV controller. (See Fig. 6 and 7.) Be sure to connect all quick connects except SR and SR+.
8. Unplug the existing jumper (used with manual damper) or harness (used with two-position damper) from PL1. Discard the jumper or harness. Connect PL1 from the EconoMiSer IV harness to PL1 on the main control harness.
9. Route PL18 through the large hole on the right side of the bottom of the control box. Secure to the bottom of the control box using snap-in wire ties.

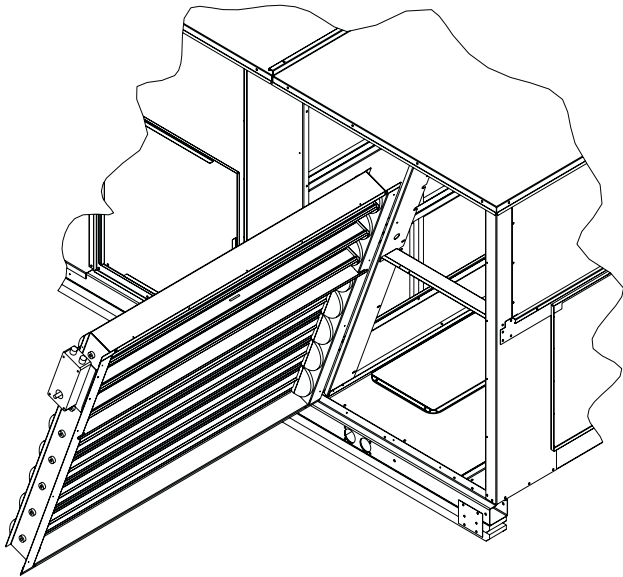

C06330

Fig. 4 – Slide Economizer Assembly into Unit

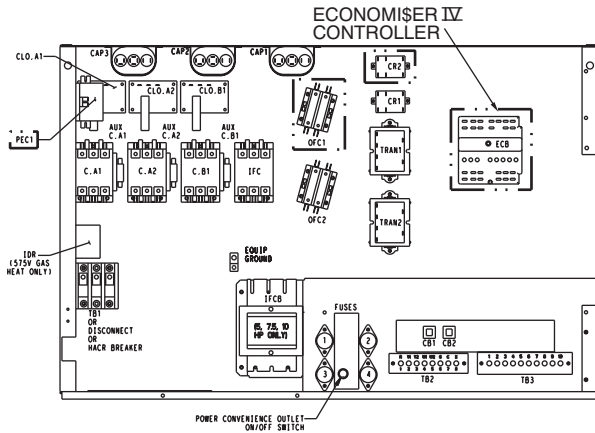

C06331

Fig. 5 – Unit Control Box

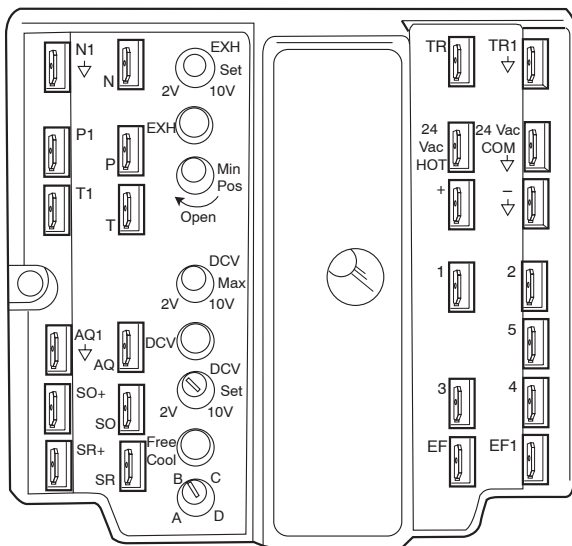

C06038

Fig. 6 – EconoMi\$er IV Controller

10. Remove the foam grommet shown in Fig. 8. Pass the wires through the hole in the control box and route into the return air section. Secure harness inside control box with 2 wires ties. Re-install the foam grommet.
11. Route the wire harness across the frame support as shown in Fig. 8. The motor plug (PL7) should be located at the actuator side of the unit and snaps into the frame support bracket. Be careful not to damage the wires. Route the harness across the back of the top member of the frame as shown and attach to the frame using the snap-in wire ties provided.
12. Connect the motor plug to the plug provided with the harness.
13. Attach the low temperature compressor lockout switch to the low temperature compressor lockout bracket using two no. 6 x 1/2-in. screws as shown in Fig. 9. Mount bracket to economizer damper frame as shown in Fig. 9 using two no. 10 x 5/8-in. screws. Connect the gray wires from the harness to the low temperature compressor lockout switch. Use a wire tie to keep the wires away from sharp edges.
14. Attach outdoor air temperature sensor to the economizer damper frame using two no. 6 x 1/2-in. screws as shown in Fig. 9. Connect the pink wire to the "+" terminal on the outdoor air temperature sensor. Connect the yellow wire to the S terminal on the outdoor air temperature sensor.
15. *48/50HJ and 551A/581A Units Only*
Examine plug PL1. If plug positions 14 and 15 have black wires installed, skip to Step 16. If black wires are not installed, insert two black wires provided into plug positions 14 and 15. Route the wires through the control box and into the indoor air section. Insert the wires in the wire track and route wires to the blower housing. Screw the wires to the center post using one no. 10 x 5/8-in. screw and the wire tie screw. Secure the wires to the fan housing using a snap-in wire tie.
16. Remove the foil tape covering the supply air temperature sensor mounting hole. Insert the supply air temperature sensor in the mounting hole. Connect the sensor to the black wires. Secure wires using wires ties provided. Be sure wires cannot touch moving parts.
17. Install the insulated partition (block-off panel) by sliding the panel into the unit from the side. The damper side of the panel will slide along the top of the flange of the damper assembly, between the return and outdoor air damper blades. The panel should then be rotated upwards so that the mounting holes align with the holes in the panels at the end of the unit. Once in the correct position, the partition will be horizontal inside the unit as shown in Fig. 10.
18. Secure the partition to the frame using the screws saved from Step 3, at the edges of the partition as shown in Fig. 11.

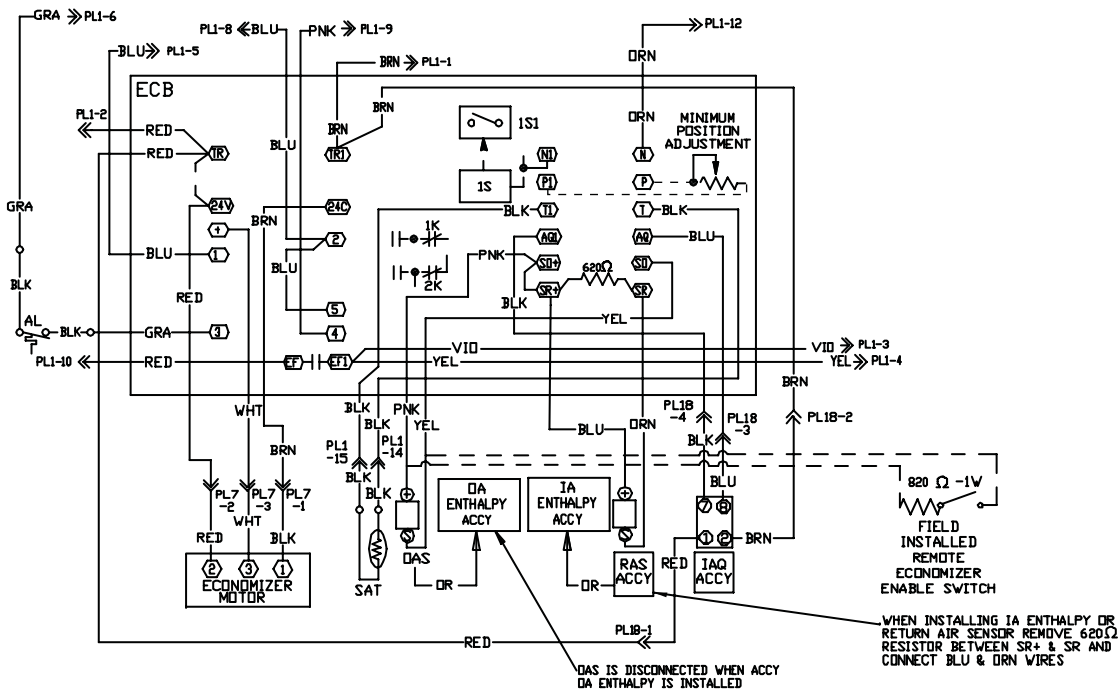

Fig. 7 – EconoMiSer IV Wiring

C06332

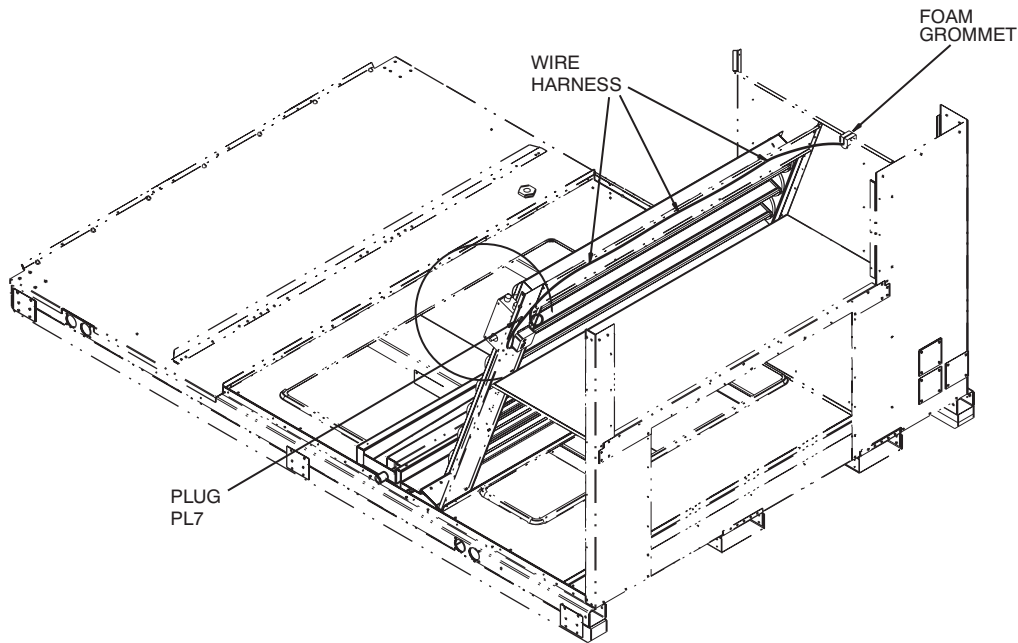

Fig. 8 – Wire Harness Routing

C06333

19. The installation of the damper assembly is now complete.

Units with Outdoor Air Hood:

If the unit was equipped with an outdoor air hood, replace the outer unit panels and outdoor air hood (if necessary) using the screws saved from the earlier steps. Be sure to inspect all panel seals prior to start-up and replace any seals that appear damaged. Install filters.

Units without Outdoor Air Hood:

If the unit was not equipped with an outdoor air hood, perform the following procedure to install the hood:

- a. Make sure power supply is off.
- b. Apply seal strip provided to back flange of both hood sides where the hood side connects to the unit back panel. (See Fig. 12.)

- c. Apply seal strip provided to top flange of both hood sides where hood sides connect to the hood top panels. (See Fig. 12.)
- d. Install hood sides to the back panels using the screws provided. The sloped flanges point outward. The drip edges of the side panels should face outward as well. Attach side filter guides to the hood sides. The flanges should face inward to hold the filters in place. (See Fig. 12.)
- e. Apply seal strip along the entire length of the bottom flange of the hood top. (See Fig. 12.)
- f. Install the lower hood top panel using 4 screws provided. (See Fig. 12.)

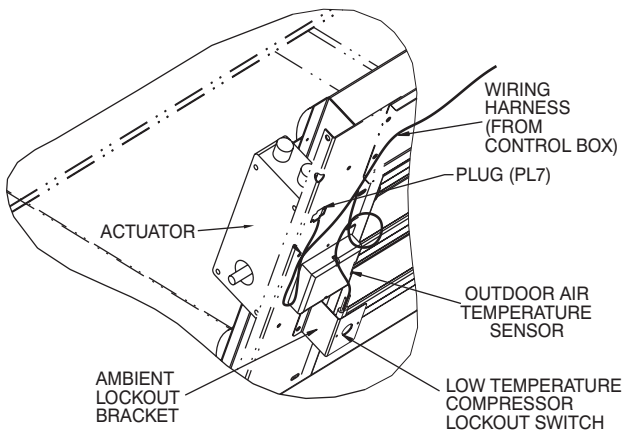

C06334

Fig. 9 – Low Temperature Compressor Lockout Switch and Outdoor Air Sensor Installation

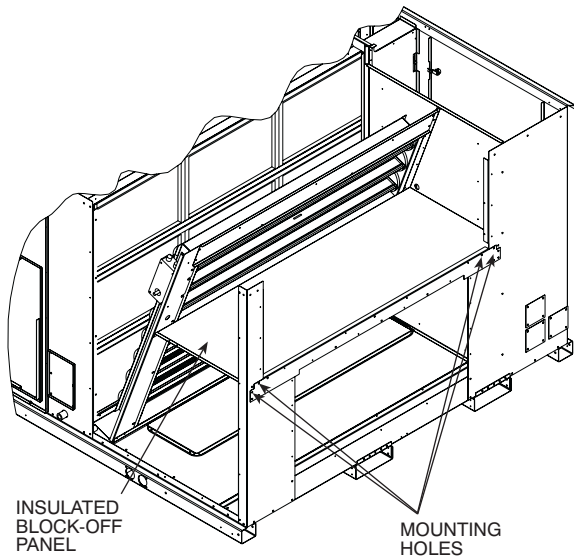

C06335

Fig. 10 – Economizer Block-Off Panel Location

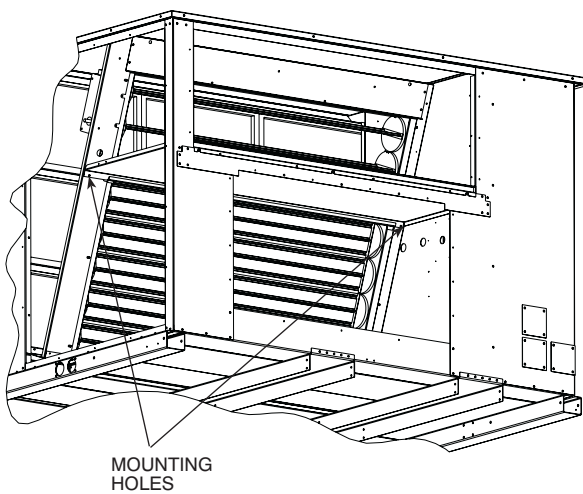

C06336

Fig. 11 – Secure Block-Off Panel to Frame

- g. Install the upper hood top panel using the 6 screws removed in Step 2. (See Fig. 12.)
- h. Install the filter retainer track along the bottom edge of the outdoor air hood using 4 screws provided. For filter removal, remove the four screws holding the filter bracket. The filters can then be removed, cleaned, or replaced.
- i. Install filters.
- j. Re-install the outdoor panel with the screws saved from Step 2. Be sure to inspect all panels prior to unit start-up. Replace any seals that appear damaged.

IMPORTANT: If the return duct opening was covered prior to installation, remember to remove the covering so as not to block off the return air to the unit.

- 20. Secure all wires so that they do not rub any sharp edges or interfere with any moving parts.
- 21. Replace the control box cover using the screws saved from Step 5. Economizer wiring is shown in Fig. 7.
- 22. Power can now safely be restored to the unit.
- 23. Inspect the unit to make sure all panels are properly replaced and secured to the unit.
- 24. Configure the unit for use with economizer.

CONFIGURATION

NOTE: The economizer static pressure drop must be accounted for after installation. (See Table 1.) Refer to the base unit installation instructions for information on adjusting the fans.

EconoMi\$er IV Standard Sensors

Outdoor-Air Temperature (OAT) Sensor

The outdoor air temperature sensor is a 10 to 20 mA device used to measure the outdoor-air temperature. The outdoor-air temperature is used to determine when the EconoMi\$er IV can be used for free cooling. The sensor is factory-installed on the EconoMi\$er IV in the outdoor airstream. The operating range of temperature measurement is 40° to 100°F.

Supply-Air Temperature (SAT) Sensor

The supply-air temperature sensor is a 3 K thermistor located at the outlet of the indoor fan. This sensor is factory installed. The operating range of temperature measurement is 0° to 158°F.

The temperature sensor is a short probe with blue wires running to it.

Low Temperature Compressor Lockout Switch

The EconoMi\$er IV is equipped with an ambient temperature lockout switch located in the outdoor airstream which is used to lockout the compressors below a 42°F ambient temperature.

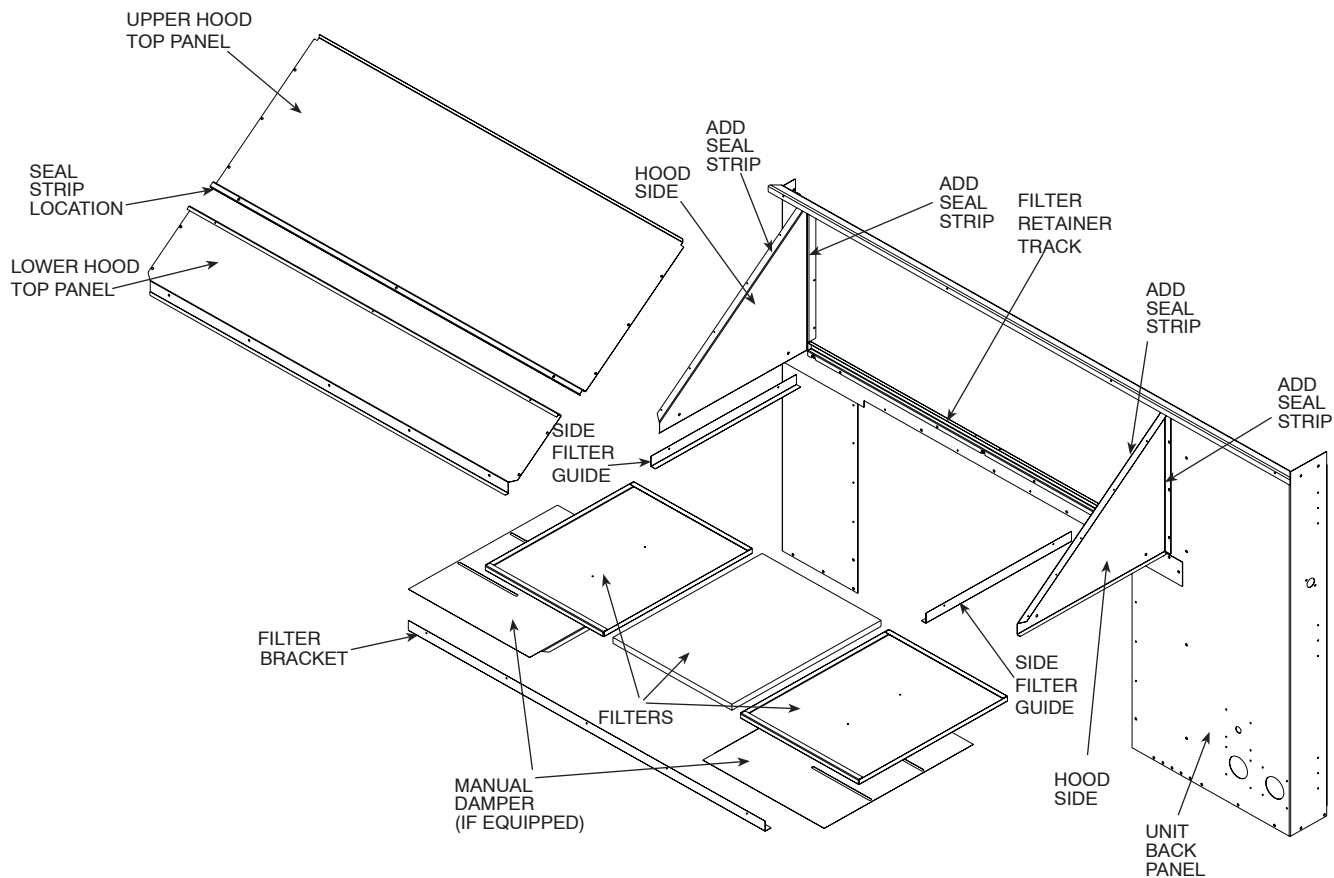

C06284

Fig. 12 – Outdoor Air Hood Details

Table 1—Accessory EconoMi\$er IV Static Pressure (in. wg)*

COMPONENT	CFM								
	4,000	4,500	5,000	5,500	6,000	6,500	7,000	7,500	8,000
Economizer	0.02	0.03	0.04	0.05	0.06	0.07	0.08	0.09	0.10

COMPONENT	CFM							
	8,500	9,000	9,500	10,000	10,500	11,000	11,500	12,000
Economizer	0.11	0.12	0.13	0.15	0.16	0.17	0.19	0.20

*The static pressure must be added to the external static pressure. The sum and the evaporator entering-air cfm should then be used in conjunction with the Fan Performance tables to determine blower rpm and watts.

EconoMi\$er IV Controller Wiring and Operational Modes

Determine the EconoMi\$er IV control mode before set up of the control. Some modes of operation may require different sensors. Refer to Table 2. The EconoMi\$er IV is supplied from the factory with a supply-air temperature sensor, a low temperature compressor lockout switch and an outdoor-air temperature sensor. This allows for operation of the EconoMi\$er IV with outdoor-air dry bulb changeover control. Additional accessories can be added to allow for different types of changeover control and operation of the EconoMi\$er IV and unit.

Outdoor Dry Bulb Changeover

The standard controller is shipped from the factory configured for outdoor dry bulb changeover control. The outdoor-air and supply-air temperature sensors are included as standard. For this control mode, the outdoor temperature is compared to an adjustable set point selected on the control. If the outdoor-air temperature is above the set point, the EconoMi\$er IV will adjust the outside-air dampers to minimum position. If the outdoor-air temperature is below the set point, the position of the outdoor-air dampers will be controlled to provided free cooling using outdoor air. When in this mode, the LED next to the free cooling set point potentiometer will be on. The changeover temperature

set point is controlled by the free cooling set point potentiometer located on the control. The scale on the potentiometer is A, B, C, and D. See Fig. 13 for the corresponding temperature changeover values.

Differential Dry Bulb Changeover

For differential dry bulb control the standard outdoor dry bulb sensor is used in conjunction with an additional accessory return air sensor (part number CRTEMPSN002A00). The accessory sensor must be mounted in the return airstream. (See Fig. 7.)

In this mode of operation, the outdoor-air temperature is compared to the return-air temperature and the lower temperature airstream is used for cooling. When using this mode of changeover control, turn the enthalpy set point potentiometer fully clockwise to the D setting.

Table 2—EconoMi\$er IV Sensor Usage

APPLICATION	ECONOMISER IV WITH OUTDOOR AIR DRY BULB SENSOR		
	Accessories Required		
Outdoor Air Dry Bulb	None. The outdoor air dry bulb sensor is factory installed.		
Differential Dry Bulb	CRTEMPSN002A00*		
Single Enthalpy	HH57AC078		
Differential Enthalpy	HH57AC078 and CRENTDIF004A00*		
CO ₂ for DCV Control using a Wall-Mounted CO ₂ Sensor	33ZCSENCO2 or CGCDXSEN004A00		
CO ₂ for DCV Control using a Duct-Mounted CO ₂ Sensor	33ZCSENCO2 or CGCDXSEN004A00† and 33ZCASPCO2 or CGCDXASP001A00**	R	CRCBDIOX005A00††

*CRENTDIF004A00 and CRTEMPSN002A00 accessories are used on many different base units. As such, these kits may contain parts that will not be needed for installation.

†33ZCSENCO2 and CGCDXSEN004A00 are accessory CO₂ sensors.

**33ZCASPCO2 and CGCDXASP001A00 are accessory aspirator boxes required for duct-mounted applications.

††CRCBDIOX005A00 is an accessory that contains both 33ZCSENCO2 and 33ZCASPCO2 accessories.

Outdoor Enthalpy Changeover

For enthalpy control, accessory enthalpy sensor (part number HH57AC078) is required. Replace the standard outdoor dry bulb temperature sensor with the accessory enthalpy sensor in the same mounting location. When the outdoor-air enthalpy rises above the outdoor enthalpy changeover set point, the outdoor-air damper moves to its minimum position. The outdoor enthalpy changeover set point is set with the outdoor enthalpy set point potentiometer on the EconoMi\$er IV controller. The set points are A, B, C, and D. (See Fig. 14 and 15.) The factory-installed 620-ohm jumper must be in place across terminals S_R and S_{R+} on the EconoMi\$er IV controller. (See Fig. 7.)

Differential Enthalpy Control

For differential enthalpy control, the EconoMi\$er IV controller uses two enthalpy sensors (HH57AC078 and CRENTDIF004A00), one in the outside air and one in the return air duct. The EconoMi\$er IV controller compares the outdoor air enthalpy to the return air enthalpy to determine EconoMi\$er IV use. The controller selects the lower enthalpy air (return or outdoor) for cooling. For example, when the outdoor air has a lower enthalpy than the return air and is below the set point, the EconoMi\$er IV opens to bring in outdoor air for free cooling.

Replace the standard outside air dry bulb temperature sensor with the accessory enthalpy sensor in the same mounting location. Mount the return air enthalpy sensor in the return air duct. Wiring is provided in the EconoMi\$er IV wiring harness. (See Fig. 7.) The outdoor enthalpy changeover set point is set with the outdoor enthalpy set point potentiometer on the EconoMi\$er IV controller. When using this mode of changeover control, turn the enthalpy setpoint potentiometer fully clockwise to the D setting.

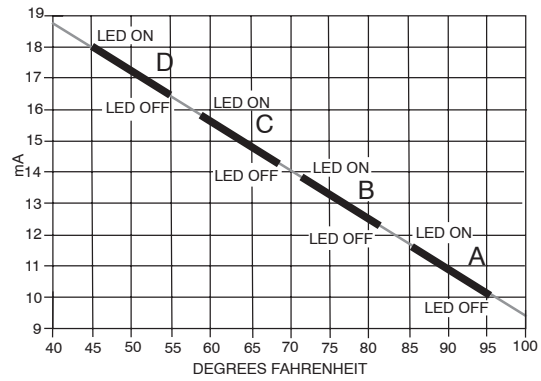

C06035

Fig. 13 – Temperature Changeover Set Points

Indoor Air Quality (IAQ) Sensor Input

The IAQ input can be used for demand control ventilation control based on the level of CO₂ measured in the space or return air duct.

Mount the optional IAQ sensor according to manufacturer specifications. The IAQ sensor should be wired to the AQ and AQ1 terminals of the controller. Adjust the DCV potentiometers to correspond to the DCV voltage output of the indoor air quality sensor at the user-determined set point. (See Fig. 15.)

If a separate field-supplied transformer is used to power the IAQ sensor, the sensor must not be grounded or the EconoMi\$er IV control board will be damaged.

Exhaust Set Point Adjustment

The exhaust set point will determine when the exhaust fan runs based on damper position (if accessory power exhaust is installed). The set point is modified with the Exhaust Fan Set Point (EXH SET) potentiometer. (See Fig. 15.) The set point represents the damper position above which the exhaust fans will be turned on. When there is a call for exhaust, the EconoMi\$er IV controller provides a 45 ± 15 second delay before exhaust fan activation to allow the dampers to open. This delay allows the damper to reach the appropriate position to avoid unnecessary fan overload.

Minimum Position Control

There is a minimum damper position potentiometer on the EconoMi\$er IV controller. (See Fig. 15.) The minimum damper position maintains the minimum airflow into the building during the occupied period.

When using demand ventilation, the minimum damper position represents the minimum ventilation position for VOC (volatile organic compounds) ventilation requirements. The maximum demand ventilation position is used for fully occupied ventilation. When demand ventilation control is not being used, the minimum position potentiometer should be used to set the occupied ventilation position. The maximum demand ventilation position should be turned fully clockwise.

Adjust the minimum position potentiometer to allow the minimum amount of outdoor air, as required by local codes, to enter the building. Make minimum position adjustments with at least 10°F temperature difference between the outdoor and return-air temperatures.

CRECOMZR

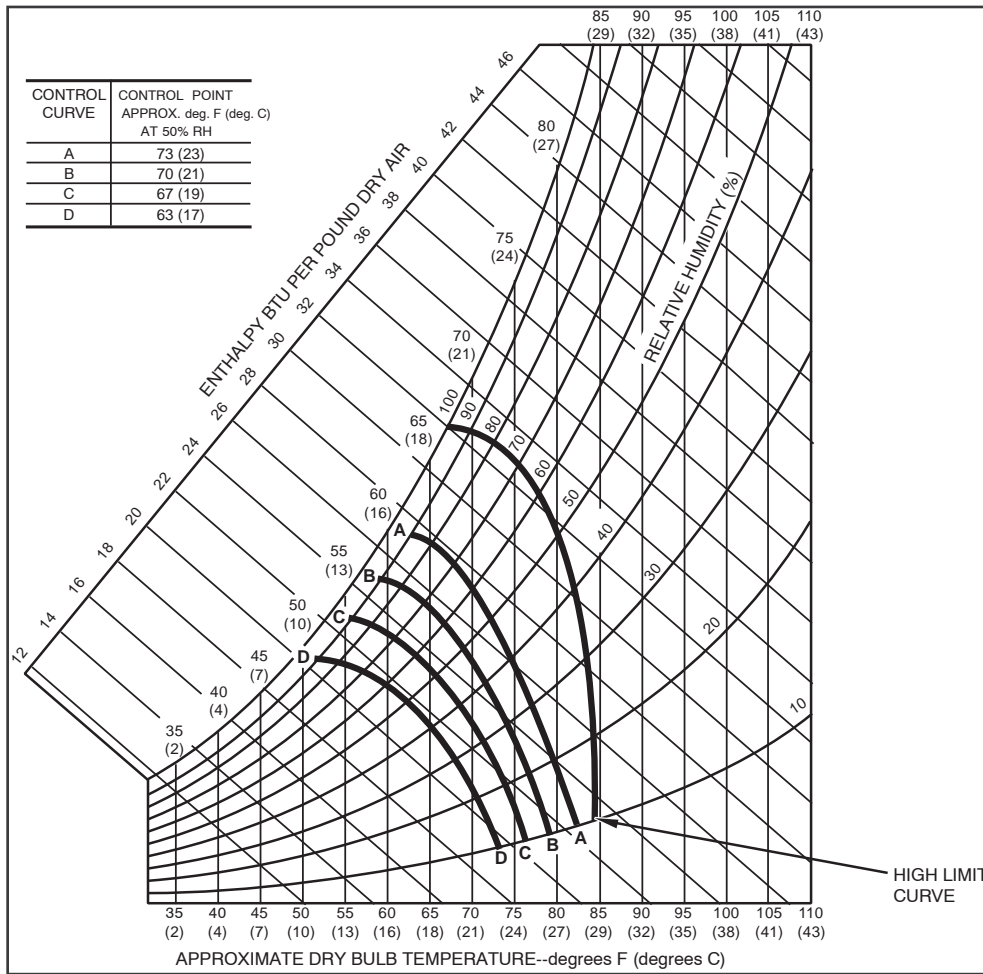

Fig. 14 – Enthalpy Changeover Set Points

C06037

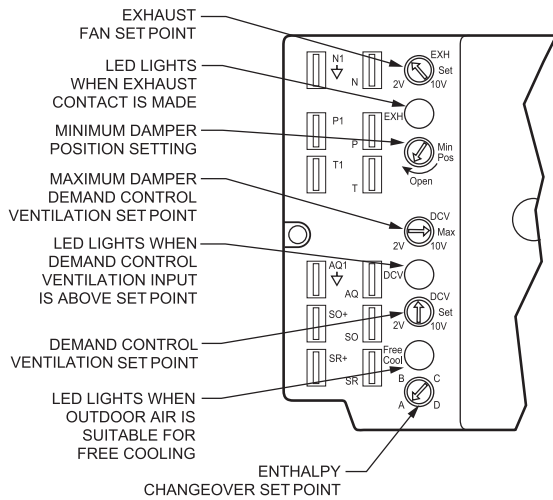

Fig. 15 – EconoMiSer IV Controller Potentiometer and LED Locations

C06034

To determine the minimum position setting, perform the following procedure:

1. Calculate the appropriate mixed-air temperature using the following formula:

$$(T_O \times \frac{OA}{100}) + (T_R \times \frac{RA}{100}) = T_M$$

T_O = Outdoor-Air Temperature
 OA = Percent of Outdoor Air
 T_R = Return-Air Temperature
 RA = Percent of Return Air
 T_M = Mixed-Air Temperature

As an example, if local codes require 10% outdoor air during occupied conditions, outdoor-air temperature is 60°F, and return-air temperature is 75°F.

$$(60 \times .10) + (75 \times .90) = 73.5^\circ F$$

2. Disconnect the supply-air sensor from terminals T and T1.
3. Ensure that the factory-installed jumper is in place across terminals P and P1. If remote damper positioning is being used, make sure that the terminals are wired according to Fig. 7 and that the minimum position potentiometer is turned fully clockwise.
4. Connect 24 vac across terminals TR and TR1.
5. Carefully adjust the minimum position potentiometer until the measured mixed-air temperature matches the calculated value.
6. Reconnect the supply-air sensor to terminals T and T1.

Remote control of the EconoMiSer IV damper is desirable when requiring additional temporary ventilation. If a field-supplied remote potentiometer (Honeywell part number S963B1128) is wired to the EconoMiSer IV controller, the minimum position of the damper can be controlled from a remote location.

To control the minimum damper position remotely, remove the factory-installed jumper on the P and P1 terminals on the EconoMi\$er IV controller. Wire the field-supplied potentiometer to the P and P1 terminals on the EconoMi\$er IV controller. (See Fig. 7.)

Damper Movement

Damper movement from full open to full closed (or vice versa) takes 2½ minutes.

Thermostats

The EconoMi\$er IV control works with conventional thermostats that have a Y1 (cool stage 1), Y2 (cool stage 2), W1 (heat stage 1), W2 (heat stage 2), and G (fan). The EconoMi\$er IV control does not support space temperature sensors. Connections are made at the thermostat terminal connection board located in the main control box.

Occupancy Control

The factory default configuration for the EconoMi\$er IV control is occupied mode. Occupied status is provided by the black jumper from terminal TR to terminal N. When unoccupied mode is desired, install a field-supplied timeclock function in place of the jumper between TR and N. (See Fig. 7.) When the timeclock contacts are closed, the EconoMi\$er IV control will be in occupied mode. When the timeclock contacts are open (removing the 24-v signal from terminal N), the EconoMi\$er IV will be in unoccupied mode.

Demand Control Ventilation

The information in this section is applicable for the 33ZCSENCO2 and CGCDXSEN004A00 sensors only. When using the EconoMi\$er IV for demand control ventilation, there are some equipment selection criteria which should be considered. When selecting the heat capacity and cool capacity of the equipment, the maximum ventilation rate must be evaluated for design conditions. The maximum damper position must be calculated to provide the desired fresh air.

Typically the maximum ventilation rate will be about 5 to 10% more than the typical cfm required per person, using normal outside air design criteria.

An exponential anticipatory strategy should be taken with the following conditions: a zone with a large area, varied occupancy, and equipment that cannot exceed the required ventilation rate at design conditions. Exceeding the required ventilation rate means the equipment can condition air at a maximum ventilation rate that is greater than the required ventilation rate for maximum occupancy. An exponential-anticipatory strategy will cause the fresh air supplied to increase as the room CO2 level increases even though the CO2 set point has not been reached. By the time the CO2 level reaches the set point, the damper will be at maximum ventilation and should maintain the set point.

In order to have the CO2 sensor control the economizer damper in this manner, first determine the damper voltage output for minimum or base ventilation. Base ventilation is the ventilation required to remove contaminants during unoccupied periods. The following equation may be used to determine the percent of outside-air entering the building for a given damper position. For best results there should be at least a 10 degree difference in outside and return-air temperatures.

$$(T_{Ox} \frac{OA}{100}) + (T_{Rx} \frac{RA}{100}) = T_M$$

- T_O = Outdoor-Air Temperature
- OA = Percent of Outdoor Air
- T_R = Return-Air Temperature
- RA = Percent of Return Air
- T_M = Mixed-Air Temperature

Once base ventilation has been determined, set the minimum damper position potentiometer to the correct position.

The same equation can be used to determine the occupied or maximum ventilation rate to the building. For example, an output of 3.6 volts to the actuator provides a base ventilation rate of 5% and an output of 6.7 volts provides the maximum ventilation rate of 20% (or base plus 15 cfm per person). Use Fig. 16 to determine the maximum setting of the CO2 sensor. For example, a 1100 ppm set point relates to a 15 cfm per person design. Use the 1100 ppm curve on Fig. 16 to find the point when the CO2 sensor output will be 6.7 volts. Line up the point on the graph with the left side of the chart to determine that the range configuration for the CO2 sensor should be 1800 ppm. The EconoMi\$er IV controller will output the 6.7 volts from the CO2 sensor to the actuator when the CO2 concentration in the space is at 1100 ppm. The DCV set point may be left at 2 volts since the CO2 sensor voltage will be ignored by the EconoMi\$er IV controller until it rises above the 3.6 volt setting of the minimum position potentiometer.

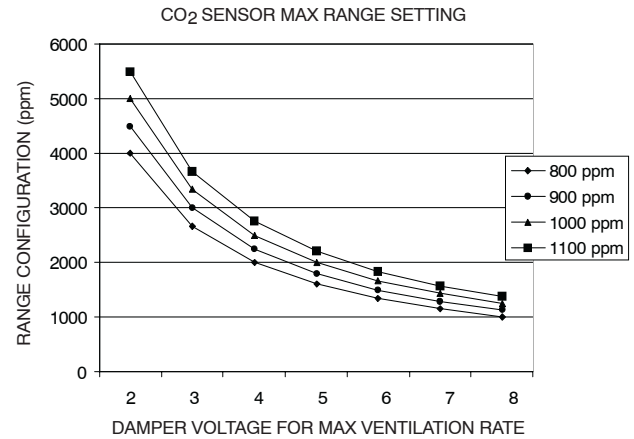

Fig. 16 – CO2 Sensor Maximum Range Setting

C06039

Once the fully occupied damper position has been determined, set the maximum damper demand control ventilation potentiometer to this position. Do not set to the maximum position as this can result in over-ventilation to the space and potential high-humidity levels.

CO2 Sensor Configuration

The CO2 sensor has preset standard voltage settings that can be selected anytime after the sensor is powered up. (See Table 3.)

Use setting 1 or 2 for Carrier or Bryant equipment. (See Table 3.)

1. Press Clear and Mode buttons. Hold at least 5 seconds until the sensor enters the Edit mode.
2. Press Mode twice. The STDSET Menu will appear.
3. Use the Up/Down button to select the preset number. (See Table 3.)
4. Press Enter to lock in the selection.
5. Press Mode to exit and resume normal operation.

The custom settings of the CO2 sensor can be changed anytime after the sensor is energized. Follow the steps below to change the non-standard settings:

1. Press Clear and Mode buttons. Hold at least 5 seconds until the sensor enters the Edit mode.
2. Press Mode twice. The STDSET Menu will appear.
3. Use the Up/Down button to toggle to the NONSTD menu and press Enter.
4. Use the Up/Down button to toggle through each of the nine variables, starting with Altitude, until the desired setting is reached.
5. Press Mode to move through the variables.
6. Press Enter to lock in the selection, then press Mode to continue to the next variable.

Table 3—CO₂ Sensor Standard Settings

SETTING	EQUIPMENT	OUTPUT	VENTILATION RATE (cfm/Person)	ANALOG OUTPUT	CO ₂ CONTROL RANGE (ppm)	OPTIONAL RELAY SETPOINT (ppm)	RELAY HYSTERESIS (ppm)
1	Interface w/Standard Building Control System	Proportional	Any	0-10V 4-20 mA	0-2000	1000	50
2		Proportional	Any	2-10V 7-20 mA	0-2000	1000	50
3		Exponential	Any	0-10V 4-20 mA	0-2000	1100	50
4	Economizer	Proportional	15	0-10V 4-20 mA	0-1100	1100	50
5		Proportional	20	0-10V 4-20 mA	0- 900	900	50
6		Exponential	15	0-10V 4-20 mA	0-1100	1100	50
7		Exponential	20	0-10V 4-20 mA	0- 900	900	50
8	Health & Safety	Proportional	—	0-10V 4-20 mA	0-9999	5000	500
9	Parking/Air Intakes/Loading Docks	Proportional	—	0-10V 4-20 mA	0-2000	700	50

LEGEND

PPM — Parts Per Million

Dehumidification of Fresh Air with DCV Control

Information from ASHRAE indicates that the largest humidity load on any zone is the fresh air introduced. For some applications, an energy recovery unit can be added to reduce the moisture content of the fresh air being brought into the building when the enthalpy is high. In most cases, the normal heating and cooling processes are more than adequate to remove the humidity loads for most commercial applications.

Operating Sequence

Cooling, Units With Economi\$er IV

When free cooling is not available, the compressors will be controlled by the zone thermostat. When free cooling is available, the outdoor-air damper is modulated by the Economi\$er IV control to provide a 50° to 55°F mixed-air temperature into the zone. As the supply-air temperature fluctuates above 55° or below 50°F, the dampers will be modulated (open or close) to bring the supply-air temperature back within control.

If mechanical cooling is utilized with free cooling, the outdoor-air damper will maintain its current position at the time the compressor is started. If the increase in cooling capacity causes the supply-air temperature to drop below 45°F, then the outdoor-air damper position will be decreased to the minimum position. If the supply-air temperature continues to fall, the outdoor-air damper will close. Control returns to normal once the supply-air temperature rises above 48°F.

If optional power exhaust is installed, as the outdoor-air damper opens and closes, the power exhaust fans will be energized and deenergized.

If field-installed accessory CO₂ sensors are connected to the Economi\$er IV control, a demand controlled ventilation strategy will begin to operate. As the CO₂ level in the zone increases above the CO₂ set point, the minimum position of the damper will be increased proportionally. As the CO₂ level decreases because of the increase in fresh air, the outdoor-air damper will be proportionally closed.

For Economi\$er IV operation, there must be a thermostat call for the fan (G). If the unit is occupied and the fan is on, the damper will operate at minimum position. Otherwise, the damper will be closed.

When the Economi\$er IV control is in the occupied mode and a call for cooling exists (Y1 on the thermostat), the control will first check for indoor fan operation. If the fan is not on, then cooling will not be activated. If the fan is on, then the control will open the Economi\$er IV damper to the minimum position.

Damper movement from full closed to full open (or vice versa) will take between 1½ and 2½ minutes.

If free cooling can be used as determined from the appropriate changeover command (switch, dry bulb, enthalpy curve, differential dry bulb, or differential enthalpy), then the control will modulate the dampers open to maintain the mixed-air temperature set point at 50 to 55°F.

If there is a further demand for cooling (cooling second stage — Y2 is energized), then the control will bring on compressor stage 1 to maintain the mixed-air temperature set point. The Economi\$er IV damper will be open at maximum position. Economi\$er IV operation is limited to a single compressor.

Heating, Gas Heat Units With Economi\$er IV

NOTE: The units have 2 stages of heat.

When the thermostat calls for heating, power is sent to W1 on the IGC (integrated gas unit controller) board. An LED (light-emitting diode) on the IGC board will be on during normal operation. A check is made to ensure that the rollout switch and limit switch are closed and the induced-draft motor is running. The induced-draft motor is then energized, and when speed is proven with the hall effect sensor on the motor, the ignition activation period begins. The burners will ignite within 5 seconds.

If the burners do not light, there is a 22-second delay before another 5-second attempt. If the burners still do not light, this sequence is repeated for 15 minutes. After the 15 minutes have elapsed, if the burners still have not lit, heating is locked out. To reset the control, break 24-v power to the thermostat.

When ignition occurs the IGC board will continue to monitor the condition of the rollout and limit switches, the hall effect sensor, as well as the flame sensor. If the unit is controlled through a room thermostat set for fan auto., 45 seconds after ignition occurs, the indoor-fan motor will be energized (and the outdoor-air dampers will open to their minimum position). If for some reason the overtemperature limit opens prior to the start of the indoor fan blower, on the next attempt, the 45-second delay will be shortened to 5 seconds less than the time from initiation of heat to when the limit tripped. Gas will not be interrupted to the burners and heating will continue. Once modified, the fan on delay will not change back to 45 seconds unless power is reset to the control.

When additional heat is required, W2 closes and initiates power to the second stage of the main gas valve. When the thermostat is satisfied, W1 and W2 open and the gas valve closes, interrupting the flow of gas to the main burners. If the call for W1 lasted less than 1 minute, the heating cycle will not terminate until 1 minute after W1 became active. If the unit is controlled through a room thermostat set for fan auto., the indoor-fan motor will continue to operate for an additional 45 seconds then stop (and the outdoor-air dampers will close). If the overtemperature limit opens after the indoor motor is stopped within 10 minutes of W1

CRECOMZR

becoming inactive, on the next cycle the time will be extended by 15 seconds. The maximum delay is 3 minutes. Once modified, the fan off delay will not change back to 45 seconds unless power is reset to the control.

When the thermostat is satisfied and W1 and W2 are deenergized, the IFM continues to run and the economizer damper then moves to the minimum position.

Heating, Electric Heat Units With Economi\$er IV

NOTE: The units have 2 stages of electric heat.

When the thermostat calls for one stage of heating, W1 is energized. The thermostat must be configured such that the blower output (G) is energized when there is a W1 call for heating. The indoor fan contactor (IFC) and first stage electric heat contactor(s) are energized, and the indoor-fan motor and first stage electric heater are started. The Economi\$er IV damper modulates to the minimum position.

If additional heating is required, the thermostat will call for a second stage of heating, energizing W2. This will energize the second stage of electric heat. The Economi\$er IV damper modulates to the minimum position.

When the thermostat is satisfied, the Economi\$er IV damper modulates closed.

TROUBLESHOOTING

See Table 4 for Economi\$er IV logic.

A functional view of the Economi\$er IV is shown in Fig. 17. Typical settings, sensor ranges, and jumper positions are also shown. An Economi\$er IV simulator program is available to help with Economi\$er IV training and troubleshooting.

Economi\$er IV Preparation

This procedure is used to prepare the Economi\$er IV for troubleshooting. No troubleshooting or testing is done by performing the following procedure.

NOTE: This procedure requires a 9-v battery, 1.2 kilo-ohm resistor, and a 5.6 kilo-ohm resistor which are not supplied with the Economi\$er IV.

IMPORTANT: Be sure to record the positions of all potentiometers before starting troubleshooting.

1. Disconnect power at TR and TR1. All LEDs should be off. Exhaust fan contacts should be open.
2. Disconnect device at P and P1.
3. Jumper P to P1.
4. Disconnect wires at T and T1. Place 5.6 kilo-ohm resistor across T and T1.
5. Jumper TR to 1.
6. Jumper TR to N.
7. If connected, remove sensor from terminals S_O and S_{O+}. Connect 1.2 kilo-ohm 4074EJM checkout resistor across terminals S_O and S_{O+}.
8. Put 620-ohm resistor across terminals S_R and S_{R+}.
9. Set minimum position, DCV set point, and exhaust potentiometers fully CCW (counterclockwise).
10. Set DCV maximum position potentiometer fully CW (clockwise).
11. Set enthalpy potentiometer to D.
12. Apply power (24 vac) to terminals TR and TR1.

Differential Enthalpy

To check differential enthalpy:

1. Make sure Economi\$er IV preparation procedure has been performed.
2. Place 620-ohm resistor across S_O and S_{O+}.
3. Place 1.2 kilo-ohm resistor across S_R and S_{R+}. The Free Cool LED should be lit.

4. Remove 620-ohm resistor across S_O and S_{O+}. The Free Cool LED should turn off.

5. Return Economi\$er IV settings and wiring to normal after completing troubleshooting.

Single Enthalpy

To check single enthalpy:

1. Make sure Economi\$er IV preparation procedure has been performed.
2. Set the enthalpy potentiometer to A (fully CCW). The Free Cool LED should be lit.
3. Set the enthalpy potentiometer to D (fully CW). The Free Cool LED should turn off.
4. Return Economi\$er IV settings and wiring to normal after completing troubleshooting.

DCV (Demand Control Ventilation) and Power Exhaust

To check DCV and Power Exhaust:

1. Make sure Economi\$er IV preparation procedure has been performed.
2. Ensure terminals AQ and AQ1 are open. The LED for both DCV and Exhaust should be off. The actuator should be fully closed.
3. Connect a 9-v battery to AQ (positive node) and AQ1 (negative node). The LED for both DCV and Exhaust should turn on. The actuator should drive to between 90 and 95% open.
4. Turn the Exhaust potentiometer CW until the Exhaust LED turns off. The LED should turn off when the potentiometer is approximately 90%. The actuator should remain in position.
5. Turn the DCV set point potentiometer CW until the DCV LED turns off. The DCV LED should turn off when the potentiometer is approximately 9 v. The actuator should drive fully closed.
6. Turn the DCV and Exhaust potentiometers CCW until the Exhaust LED turns on. The exhaust contacts will close 30 to 120 seconds after the Exhaust LED turns on.
7. Return Economi\$er IV settings and wiring to normal after completing troubleshooting.

DCV Minimum and Maximum Position

To check the DCV minimum and maximum position:

1. Make sure Economi\$er IV preparation procedure has been performed.
2. Connect a 9-v battery to AQ (positive node) and AQ1 (negative node). The DCV LED should turn on. The actuator should drive to between 90 and 95% open.
3. Turn the DCV Maximum Position potentiometer to midpoint. The actuator should drive to between 20 and 80% open.
4. Turn the DCV Maximum Position potentiometer to fully CCW. The actuator should drive fully closed.
5. Turn the Minimum Position potentiometer to midpoint. The actuator should drive to between 20 and 80% open.
6. Turn the Minimum Position Potentiometer fully CW. The actuator should drive fully open.
7. Remove the jumper from TR and N. The actuator should drive fully closed.
8. Return Economi\$er IV settings and wiring to normal after completing troubleshooting.

Supply-Air Input

To check supply-air input:

1. Make sure EconoMi\$er IV preparation procedure has been performed.
2. Set the Enthalpy potentiometer to A. The Free Cool LED turns on. The actuator should drive to between 20 and 80% open.
3. Remove the 5.6 kilo-ohm resistor and jumper T to T1. The actuator should drive fully open.
4. Remove the jumper across T and T1. The actuator should drive fully closed.
5. Return EconoMi\$er IV settings and wiring to normal after completing troubleshooting.

EconoMi\$er IV Troubleshooting Completion

This procedure is used to return the EconoMi\$er IV to operation. No troubleshooting or testing is done by performing the following procedure.

1. Disconnect power at TR and TR1.

2. Set enthalpy potentiometer to previous setting.
3. Set DCV maximum position potentiometer to previous setting.
4. Set minimum position, DCV set point, and exhaust potentiometers to previous settings.
5. Remove 620-ohm resistor from terminals S_R and S_{R+}.
6. Remove 1.2 kilo-ohm checkout resistor from terminals S_O and S_{O+}. If used, reconnect sensor from terminals S_O and S_{O+}.
7. Remove jumper from TR to N.
8. Remove jumper from TR to 1.
9. Remove 5.6 kilo-ohm resistor from T and T1. Reconnect wires at T and T1.
10. Remove jumper from P to P1. Reconnect device at P and P1.
11. Apply power (24 vac) to terminals TR and TR1.

Table 4—EconoMi\$er IV Input/Output Logic

INPUTS					OUTPUTS			
Demand Control Ventilation (DCV)	Enthalpy*		Y1	Y2	Compressor		N Terminal†	
	Outdoor	Return			Stage	Stage	Occupied	Unoccupied
			1	2	Damper			
Below set (DCV LED Off)	High (Free Cooling LED Off)	Low	On	On	On	On	Minimum position	Closed
			On	Off	On	Off		
			Off	Off	Off	Off		
	Low (Free Cooling LED On)	High	On	On	On	Off	Modulating** (between min. position and full-open)	Modulating** (between closed and full-open)
			On	Off	Off	Off		
			Off	Off	Off	Off		
Above set (DCV LED On)	High (Free Cooling LED Off)	Low	On	On	On	On	Modulating†† (between min. position and DCV maximum)	Modulating†† (between closed and DCV maximum)
			On	Off	On	Off		
			Off	Off	Off	Off		
	Low (Free Cooling LED On)	High	On	On	On	Off	Modulating***	Modulating†††
			On	Off	Off	Off		
			Off	Off	Off	Off		

*For single enthalpy control, the module compares outdoor enthalpy to the ABCD set point.

†Power at N terminal determines Occupied/Unoccupied setting: 24 vac (Occupied), no power (Unoccupied).

**Modulation is based on the supply-air sensor signal.

††Modulation is based on the DCV signal.

***Modulation is based on the greater of DCV and supply-air sensor signals, between minimum position and either maximum position (DCV) or fully open (supply-air signal).

†††Modulation is based on the greater of DCV and supply-air sensor signals, between closed and either maximum position (DCV) or fully open (supply-air signal).

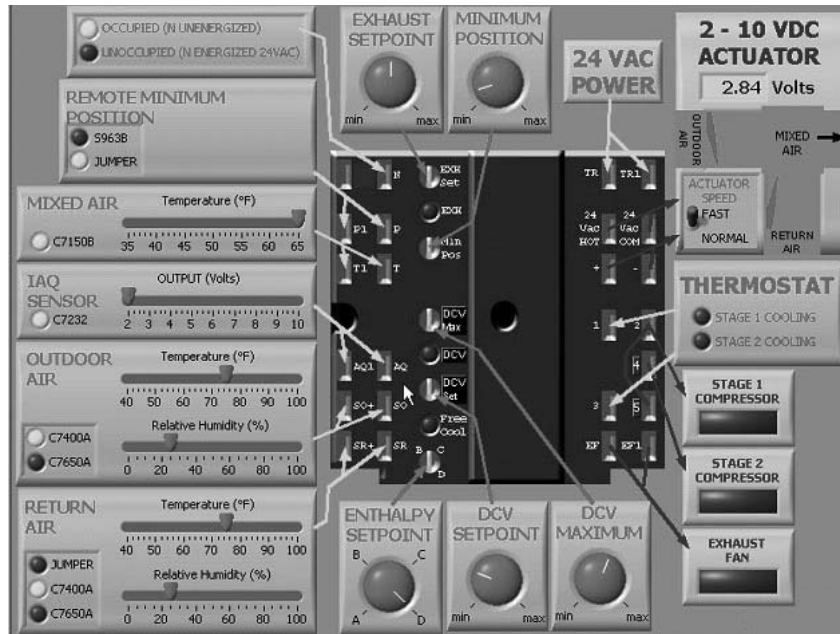

Fig. 17 – EconoMiSer IV Functional View

C06053