

**EconoMi\$er X**  
**Factory–Installed Option**  
**Low Leak Economizer**  
**for 2 Speed SAV (Staged Air Volume) Systems**



## Installation, Setup & Troubleshooting Supplement

**This document is a supplemental installation instruction for the factory-installed EconoMi\$er X (low leak economizer) option. It is to be used with the base unit Installation Instructions for 48/50TC, 50TCQ, 48/50HC, and 50HCQ 2-Stage cooling units, sizes 08 – 30. Units equipped with the EconoMi\$er X option are identified by an indicator in the unit's model number (see the unit's nameplate). Use Table 1 (on page 2) to identify whether or not a given unit is equipped with the factory-installed EconoMi\$er X.**

**NOTE:** Read the entire instruction manual before starting the installation.

### TABLE OF CONTENTS

SAFETY CONSIDERATIONS .....	1
GENERAL .....	2
Identifying Factory Option .....	2
EconoMi\$er X .....	3
W7220 Economizer Controller .....	3
User Interface .....	3
Menu Structure .....	3
Checkout Tests .....	7
SETUP AND CONFIGURATION .....	7
W7220 Economizer Module Wiring .....	7
Time-Out and Screen Saver .....	7
Enthalpy Settings .....	8
Enthalpy Control Sensor Configuration .....	8
Install Outside Air Hood — Factory Option .....	9
15 to 25 Ton Horizontal Return Application with .....	9
Barometric Relief .....	9
OPERATION .....	10
Cooling, Unit with EconoMi\$er X .....	10
Heating, Unit with EconoMi\$er X .....	10
Demand Control Ventilation .....	10
TROUBLESHOOTING .....	11
Power Loss (Outage or Brownout) .....	11
Alarms .....	11
Clearing Alarms .....	11

### SAFETY CONSIDERATIONS

Improper installation, adjustment, alteration, service, maintenance, or use can cause explosion, fire, electrical shock or other conditions which may cause personal injury or property damage. Consult a qualified installer, service agency, or your distributor or branch for information or assistance. The qualified installer or agency must use factory-authorized kits or accessories when modifying this product. Refer to the individual instructions packaged with the kits or accessories when installing.

Follow all safety codes. Wear safety glasses and work gloves. Use quenching cloths for brazing operations and have a fire extinguisher available. Read these instructions thoroughly and follow all warnings or cautions attached to the unit. Consult local building codes and appropriate national electrical codes (in USA, ANSI/NFPA70, National Electrical Code (NEC); in Canada, CSA C22.1) for special requirements.

It is important to recognize safety information. This is the safety-alert symbol . When you see this symbol on the unit and in instructions or manuals, be alert to the potential for personal injury.

Understand the signal words DANGER, WARNING, CAUTION, and NOTE. These words are used with the safety-alert symbol.

DANGER identifies the most serious hazards which **will** result in severe personal injury or death. WARNING signifies hazards which **could** result in personal injury or death.

CAUTION is used to identify unsafe practices, which **may** result in minor personal injury or product and property damage.

NOTE is used to highlight suggestions which **will** result in enhanced installation, reliability, or operation.

## GENERAL

### ⚠ WARNING

#### ELECTRICAL SHOCK HAZARD

Failure to follow this warning could cause personal injury or death.

Before performing service or maintenance operations on unit, always turn off main power switch to unit and install lock(s) and lockout tag(s). Unit may have more than one power switch. Ensure electrical service to rooftop unit agrees with voltage and amperage listed on the unit rating plate.

### ⚠ CAUTION

#### CUT HAZARD

Failure to follow this caution may result in personal injury.

Sheet metal parts may have sharp edges or burrs. Use care and wear appropriate protective clothing, safety glasses and gloves when handling parts and servicing air conditioning equipment.

LLECON-01SI

### Identifying Factory Option

NOTE: This supplement only applies to units that meet the criteria detailed in Table 1. If the unit does not meet that criteria, discard this document.

**Table 1 – Model-Size / EconoMiSer X Option Indicator**

Model / Sizes	Position in Model Number	EconoMiSer FIOP Indicator
48/50TC / 08-16	15	U or W
48/50TC / 17-30	15	U, V, W or X
50TCQ / 08-14	15	U or W
50TCQ / 17-24	15	U, V, W or X
48/50HC / 08-14	15	U or W
48/50HC / 17-28	15	U, V, W or X
50HCQ / 08-12	15	U or W

NOTE: See Fig. 1 for an example of typical Model Number Nomenclature.

In addition to criteria in Table 1, all units equipped with a factory-installed EconoMiSer X display a 6 in the 14<sup>th</sup> position of the model number indicating the low leak economizer controller. These units also display a G in the 17<sup>th</sup> position of the model number to indicate that the unit is equipped with the factory-installed VFD (Variable Frequency Drive) option for 2-speed indoor fan control. The VFD option is required for units equipped with EconoMiSer X. For detailed information on the VFD see the Variable Frequency Drive (VFD) Installation, Setup & Troubleshooting Supplement.

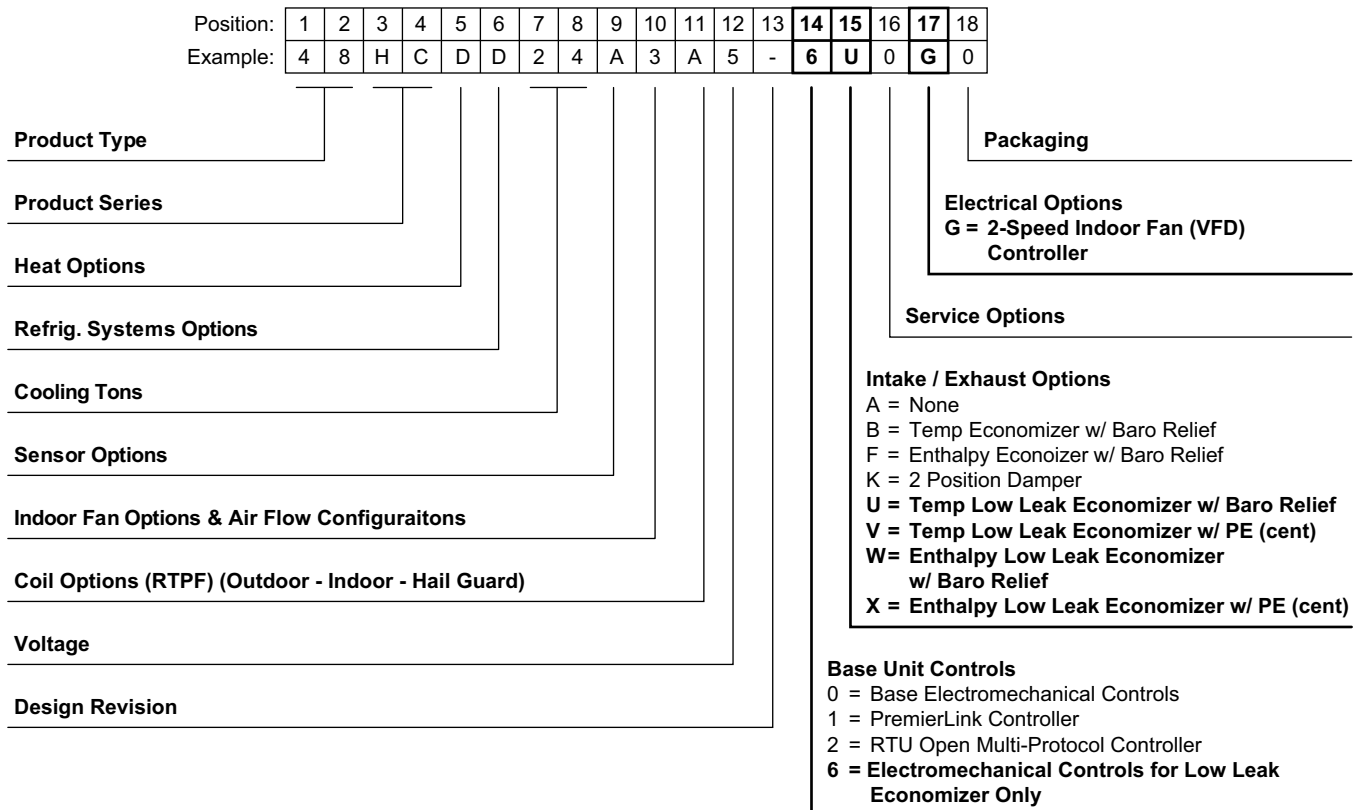

**Fig. 1 - Model Number Nomenclature Example**

C11547

## EconoMi\$er X

EconoMi\$er X is a low leak economizer system which is available for 2-stage cooling units equipped with the SAV 2-speed Variable Frequency Drive (VFD) system.

The factory-installed option consist of the following:

- Low leak economizer assembly
- W7220 economizer controller
- 20K dry bulb temperature control sensor
- Enthalpy control sensor (enthalpy economizer only)

### W7220 Economizer Controller

The economizer controller used on electro mechanical units is a Honeywell W7220 which is located in the RTU base unit's Control Box. See the Installation Instructions for your base unit for the location of the Control Box access panel.

The W7220 controller provide the following:

- 2-line LCD interface screen for setup, configuration and troubleshooting.
- On-board fault detection and diagnostics
- Sensor failure loss of communications identification
- Automatic sensor detection
- Capabilites for use with multiple-speed indoor fan systems

### User Interface

The user interface consists of an LCD display and a 4-button keypad on the front of the economizer controller.

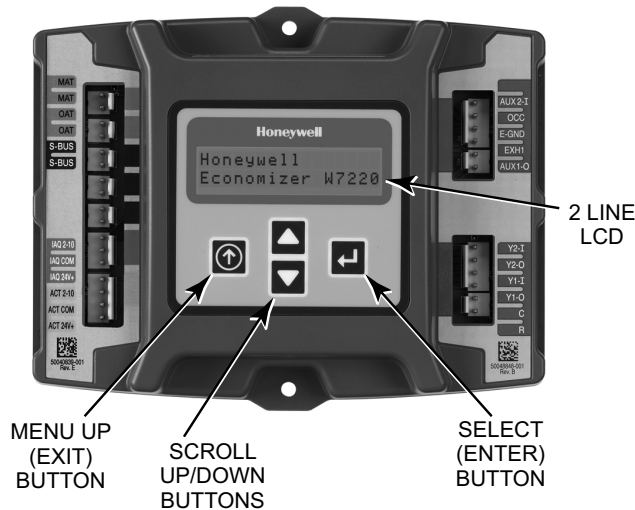

Fig. 2 - W7220 Controller

C11548

### Keypad

The four navigation buttons (see Fig. 2) are used to scroll through the menus and menu items, select menu items, and to change parameter and configuration settings.

### Using the Keypad with Menus

To use the keypad when working with menus:

- Press the ▲ (Up arrow) button to move to the previous menu.
- Press the ▼ (Down arrow) button to move to the next menu.
- Press the ↵ (Enter) button to display the first item in the currently displayed menu.
- Press the ⏪ (Menu Up/Exit) button to exit a menu's item and return to the list of menus.

### Using the Keypad with Settings and Parameters

To use the keypad when working with Setpoints, System and Advanced Settings, Checkout tests and Alarms:

1. Navigate to the desired menu.
  2. Press the ↵ (Enter) button to display the first item in the currently displayed menu.
  3. Use the ▲ and ▼ buttons to scroll to the desired parameter.
  4. Press the ↵ (Enter) button to display the value of the currently displayed item.
  5. Press the ▲ button to increase (change) the displayed parameter value.
  6. Press the ▼ button to decrease (change) the displayed parameter value.
- NOTE:** When values are displayed, pressing and holding the ▲ or ▼ button causes the display to automatically increment.
7. Press the ↵ (Enter) button to accept the displayed value and store it in nonvolatile RAM.
  8. "CHANGE STORED" displays.
  9. Press the ↵ (Enter) button to return to the current menu parameter.
  10. Press the ⏪ (Menu Up/Exit) button to return to the previous menu.

### Menu Structure

Table 2 illustrates the complete hierarchy of menus and parameters for the Economizer X system.

The Menus in display order are:

- STATUS
- SETPOINTS
- SYSTEM SETUP
- ADVANCED SETUP
- CHECKOUT
- ALARMS

**IMPORTANT:** Table 2 illustrates the complete hierarchy. your menu parameters may be different depending on your configuration. For example if you do not have a DCV (CO<sub>2</sub>) sensor, then none of the DCV parameters appear.

**Table 2 – Menu Structure<sup>a</sup>**

Menu	Parameter	Parameter Default Value	Parameter Range and Increment <sup>b</sup>	Notes
STATUS	ECON AVAIL	NO	YES/NO	YES = economizing available; the system can use outside air for free cooling when required
	ECONOMIZING	NO	YES/NO	YES = outside air being used for 1 <sup>st</sup> stage cooling.
	OCCUPIED	NO	YES/NO	YES = OCC signal received from space thermostat or unitary controller. YES = 24 Vac on terminal OCC. NO = 0 Vac on terminal OCC.
	HEAT PUMP	n/a <sup>c</sup>	COOL HEAT	Displays COOL or HEAT when system is set to heat pump (non-conventional)
	COOL Y1-IN	OFF	ON/OFF	Y1-I signal from space thermostat or unitary controller for cooling stage 1. ON = 24 Vac on terminal Y1-I OFF = 0Vac on terminal Y1-I
	COOL Y1-OUT	OFF	ON/OFF	Cool stage 1 Relay Output to stage 1 mechanical cooling (Y1-OUT terminal)
	COOL Y2-IN	OFF	ON/OFF	Y2-I signal from space thermostat our unitary controller for second stage cooling. ON = 24 Vac on terminal Y2-I OFF = 0 Vac on terminal Y2-I
	COOL Y2-OUT	OFF	ON/OFF	Cool Stage 2 Relay Output to mechanical cooling (Y2-OUT terminal).
	MA TEMP	___ °F	0 to 140 °F	Displays value of measured mixed air from MAT sensor. Displays --.- if not connected, short or out-of-range.
	DA TEMP	___ °F	0 to 140 °F	Displays when Discharge Air sensor is connected and displays measured discharge temperature. Displays ___ . ___ °F if sensor sends invalid value, if not connected, short or out-of-range.
	OA TEMP	___ °F	-40 to 140 °F	Displays measured value of outdoor air temperature. Displays ___ . ___ °F if sensor sends invalid value, if not connected, short or out-of-range.
	OA HUM	__%	0 to 100%	Displays measured value of outdoor humidity from OA sensor. Displays __% if not connected short, or out-of-range.
	RA TEMP	___ °F	0 to 140 °F	Displays measured value of return air temperature from RAT sensor. Displays ___ . ___ °F if sensor sends invalid value, if not connected, short or out-of-range.
	RA HUM	__%	0 to 100%	Displays measured value of return air humidity from RA sensor. Displays __% if sensor sends invalid value, if not connected, short or out-of-range.
	IN CO2	___ ppm	0 to 2000 ppm	Displays value of measured CO <sub>2</sub> from CO <sub>2</sub> sensor. Invalid if not connected, short or out-of-range.
	DCV STATUS	n/a	ON/OFF	Displays ON if above setpoint and OFF if below setpoint, and ONLY if a CO <sub>2</sub> sensor is connected.
	DAMPER OUT	2.0V	2.0 to 10.0V	Displays voltage output to the damper actuator.
	EXH1 OUT	OFF	ON/OFF	Output of EXH1 terminal: ON = relay closed OFF = relay open
	EXH2 OUT	OFF	ON/OFF	Output of AUX terminal; displays only if AUX = EXH2
	ERV	OFF	ON/OFF	Output of AUX terminal; displays only if AUX = ERV
MECH COOL ON	0	0, 1, or 2	Displays stage of mechanical cooling that is active.	

LLECON-01SI

**Table 2 - Menu Structure<sup>a</sup> (cont)**

Menu	Parameter	Parameter Default Value	Parameter Range and Increment <sup>b</sup>	Notes
<b>SETPOINTS</b>	MAT SET	53°F	38 to 65°F; increment by 1	Setpoint determines where the economizer will modulate the OA damper to maintain the mixed air temperature.
	LOW T LOCK	32°F	-45 to 80°F; increment by 1	Setpoint determines outdoor temperature when the mechanical cooling cannot be turned on. Commonly referred to as the Compressor lockout.
	DRYBLB SET	63°F	48 to 80°F; increment by 1	Setpoint determines where the economizer will assume outdoor air temperature is good for free cooling; e.g.: at 63°F unit will economize at 62°F and below and not economize at 64°F and above. There is a 2°F deadband.
	ENTH CURVE	ES3	ES1, ES2, ES3, ES4, or ES5	Enthalpy boundary "curves" for economizing using single enthalpy.
	DCV SET	1100ppm	500 to 2000 ppm; increment by 100	Displays only if CO <sub>2</sub> sensor is connected. Setpoint for Demand Control Ventilation of space. Above the setpoint, the OA dampers will modulate open to bring in additional OA to maintain a space ppm level below the setpoint.
	MIN POS	4.4 V	2 to 10 Vdc	Displays ONLY if a CO <sub>2</sub> sensor is NOT connected.
	VENTMAX With 2-speed fan units VENTMAX L (low speed fan) and VENTMAX H (high speed fan) settings are required	4.4 V	2 to 10 Vdc or 100 to 9990 cfm increment by 10	Displays only if a CO <sub>2</sub> sensor is connected. Used for Vbz (ventilation max cfm) setpoint. Displays 2 to 10 V if <3 sensors (RA, OA and MA). In AUTO mode dampers controlled by CFM.
	VENTMAX L	6 V		
	VENTMAX H	4.4 V		
	VENTMIN With 2-speed fan units VENTMIN L (low speed fan) and VENTMIN H (high speed fan) set	2.8 V	2 to 10 Vdc or 100 to 9990 cfm increment by 10	Displays only if a CO <sub>2</sub> sensor is connected. Used for Va (ventilation min cfm) setpoint. Displays 2 to 10 V if <3 sensors (RA, OA and MA). Va is only set if DCV is used. This is the ventilation for less than maximum occupancy of the space. In AUTO mode dampers controlled by CFM.
	VENTMIN L	3.7 V		
	VENTMIN H	2.8 V		
	ERV OAT SP	32°F	0 to 50°F; increment by 1	Only when AUX1 O = ERV
	EXH1 SET With 2-speed fan units Exh1 L (low speed fan) and Exh1 H (high speed fan) settings are required	50%	0 to 100%; increment by 1	Setpoint for OA damper position when exhaust fan 1 is powered by the economizer.
	Exh1 L	65%		
	Exh1 H	50%		
	EXH2 SET With 2-speed fan units Exh2 L (low speed fan) and Exh2 H (high speed fan) settings are required	75%	0 to 100%; increment by 1	Setpoint for OA damper position when exhaust fan 2 is powered by the economizer. Only used when AUX is set to EHX2.
	Exh2 L	80%		
Exh2 H	75%			
<b>SYSTEM SETUP</b>	INSTALL	01/01/10		Display order = MM/DD/YY Setting order = DD, MM, then YY.
	UNITS DEG	°F	°F or °C	Sets economizer controller in degrees Fahrenheit or Celsius.
	EQUIPMENT	CONV	Conventional or HP	CONV = conventional; HP O/B = Enable Heat Pump mode. Use AUX2 I for Heat Pump input from thermostat or controller.
	AUX2 I	W	SD/W or HP(O)/HP(B)	In CONV mode: SD + Enables configuration of shutdown (default); W = Informs controller that system is in heating mode. In HP O/B mode: HP(O) = energize heat pump on Cool (default); HP(B) = energize heat pump on Heat.
	FAN TYPE	2 speed	1 speed/2 speed	Sets the economizer controller for operation of 1 speed or 2 speed supply fan.
	FAN CFM	5000cfm	100 to 15000 cfm; increment by 100	This is the capacity of the RTU. The value is found in the Project Submittal documents for the specific RTU.
	AUX OUT	NONE	NONE ERV EXH2 SYS	<ul style="list-style-type: none"> <li>NONE = not configured (output is not used)</li> <li>ERV = Energy Recovery Ventilator<sup>d</sup></li> <li>EXH2 = second damper position relay closure for second exhaust fan</li> <li>SYS = use output as an alarm signal</li> </ul>
	OCC	INPUT	INPUT or ALWAYS	When using a setback thermostat with occupancy out (24 Vac), the 24 Vac is input "INPUT" to the OCC terminal. If no occupancy output from the thermostat then change program to "ALWAYS" OR ad a jumper from terminal R to OCC terminal.

**LLECON-01SI**

Table 2 - Menu Structure<sup>a</sup> (cont)

Menu	Parameter	Parameter Default Value	Parameter Range and Increment <sup>b</sup>	Notes
<b>SYSTEM SETUP (cont)</b>	FACTORY DEFAULT	NO	NO or YES	Resets all set points to factory defaults when set to YES. LCD will briefly flash YES and change to NO but all parameters will change to the factory default values.
<b>ADVANCED SETUP</b>	MA LO SET	45°F	35 to 55°F; Incremented by 1°	Temperature to achieve Freeze Protection (close damper and alarm if temperature falls below setup value)
	FREEZE POS	CLO	CLO or MIN	Damper position when freeze protection is active (closed or MIN POS).
	CO2 ZERO	0ppm	0 to 500 ppm; Increment by 10	CO <sub>2</sub> ppm level to match CO <sub>2</sub> Sensor start level.
	CO2 SPAN	2000ppm	1000 to 3000 ppm; Increment by 50	CO <sub>2</sub> ppm span to match CO <sub>2</sub> sensor.
	STG3 DLY	2.0h	0 min, 5 min, 15 min, then 15 min intervals. Up to 4 h or OFF	Delay after stage 2 for cool has been active. Turns on 2 <sup>nd</sup> stage of cooling when economizer is 1 <sup>st</sup> stage and mechanical cooling is 2 <sup>nd</sup> stage. Allows three stages of cooling, 1 economizer and 2 mechanical. OFF = no Stage 3 cooling.
	SD DMPR POS	CLO	CLO or OPN	Indicates shutdown signal from space thermostat or unitary controller. When controller receives 24 Vac input on the SD terminal in conventional mode, the OA damper will open if programmed for OPN and OA damper will close if programmed for CLO. All other controls, e.g., fans, etc. will shut off.
	DCV CAL ENA	MAN	MAN (manual) AUTO	Turns on the DCV automatic control of the dampers. Resets ventilation based on the RA, OA and MA sensor conditions. Requires all 3 RA, OA and MA sensors.
	MAT T CAL	0.0°F	+/-2.5°F	Allows for the operator to adjust for an out of calibration temperature sensor
	OA T CAL	0.0°F	+/-2.5°F	Allows for the operator to adjust for an out of calibration temperature sensor
	OA H CAL	0% RH	+/-10% RH	Allows for the operator to adjust for an out of calibration humidity sensor
	RA T CAL	0.0°F	+/-2.5°F	Allows for the operator to adjust for an out of calibration temperature sensor
	RA H CAL	0% RH	+/-10% RH	Allows for the operator to adjust for an out of calibration humidity sensor
	DA T CAL	0.0°F	+/-2.5°F	Allows for the operator to adjust for an out of calibration temperature sensor
<b>CHECKOUT</b>	DAMPER VMIN-HS	n/a	n/a	Positions damper to VMIN position
	DAMPER VMAX-HS	n/a	n/a	Positions damper to VMAX position
	DAMPER OPEN	n/a	n/a	Positions damper to the full open position. Exhaust fan contacts enable during the DAMPER OPEN test. Make sure you pause in this mode to allow exhaust contacts to energize due to the delay in the system.
	DAMPER CLOSE	n/a	n/a	Positions damper to the fully closed position
	CONNECT Y1-O	n/a	n/a	Closes the Y1-O relay (Y1-O)
	CONNECT Y2-O	n/a	n/a	Closes the Y2-O relay (Y2-O)
	CONNECT AUX	n/a	n/a	Energizes the AUX output. If Aux setting is: <ul style="list-style-type: none"> <li>• NONE – not action taken</li> <li>• ERV – 24 Vac out. Turns on or signals an ERV that the conditions are not good for economizing but are good for ERV operation.<sup>d</sup></li> <li>• SYS – 24 Vac out. Issues a system alarm</li> </ul>
<b>ALARMS()</b>	MA T SENS ERR	n/a	n/a	Alarms display only when they are active. The menu title "ALARMS()" includes the number of active alarms in parenthesis ( ).
	CO2 SENS ERR	n/a	n/a	
	OA T SENS ERR	n/a	n/a	
	DA ENTHL ERR	n/a	n/a	
	SYS ALARM	n/a	n/a	When AUX is set to SYS and there is any alarm (e.g., failed sensors, etc.), the AUX terminal has 24 Vac out.
<b>NOTE:</b> The alarms listed are examples. Additional alarms display depending on the parameter settings and configuration. For example if you do not have a DCV (CO <sub>2</sub> ) sensor, then none of the DCV parameters appear.				

LLECON-01SI

<sup>a</sup> Table 2 illustrates the complete hierarchy. your menu parameters may be different depending on your configuration. For example if you do not have a DCV (CO<sub>2</sub>) sensor, then none of the DCV parameters appear.

<sup>b</sup> When values are displayed, pressing and holding the ▲ or ▼ button causes the display to automatically increment.

<sup>c</sup> n/a = not applicable

<sup>d</sup> ERV Operation: When in Cooling mode AND the conditions are NOT OK for economizing – the ERV terminal will be energized. In the Heating mode the ERV terminal will be energized when the OA is below the ERV OAT setpoint in the setpoint menu.

## Checkout Tests

Use the Checkout menu (see Table 2 on page 6) to test the damper operation and any configured outputs. Only items that are configured are shown in the Checkout menu.

**NOTE:** See User Interface on page 3 for information about menu navigation and use of the keypad.

To perform a Checkout test:

1. Scroll to the desired test in the Checkout menu using the the ▲ and ▼ buttons.
2. Press the ↵ button to select the item.
3. RUN? appears.
4. Press the ↵ button to start the test.
5. The unit pauses and then displays IN PROGRESS.
6. When the test is complete, DONE appears.
7. When all desired parameters have been tested, press the ⏸ (Menu up) button to end the test.

Checkout tests can be performed at any time during the operation of the system as a test that the system is operable.

**▲ CAUTION**

**EQUIPMENT DAMAGE HAZARD**

Failure to follow this caution may result in equipment damage.

Be sure to allow enough time for compressor startup and shutdown between checkout tests so that you do not short-cycle the compressors.

## SETUP AND CONFIGURATION

### W7220 Economizer Module Wiring

Use Fig. 3 and Tables 3 and 4 to locate the wiring terminals for the Economizer module.

**NOTE:** The four terminal blocks are removable. You can slide out each terminal block, wire it, and then slide it back into place.

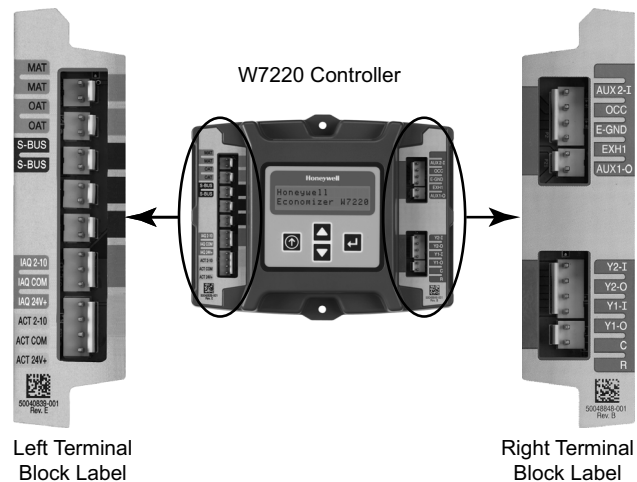

C12014

**Fig. 3 - W7220 Economizer Module Terminal Connection Labels**

**Table 3 – Economizer Module - Left Hand Terminal Blocks**

Label	Type	Description
<b>Top Left Terminal Block</b>		
MAT MAT	20k NTC and COM	Mixed Air Temperature Sensor (polarity insensitive connection)
OAT OAT	20k NTC and COM	Outdoor Air Temperature Sensor (polarity insensitive connection)
S-BUS S-BUS	S-Bus (Sylk Bus)	Enthalpy Control Sensor (polarity insensitive connection)
<b>Bottom Left Terminal Block</b>		
IAQ 2-10	2-10 Vdc	Air Quality Sensor Input (e.g. CO <sub>2</sub> sensor)
IAQ COM	COM	Air Quality Sensor Common
IAQ 24V	24 Vac	Air Quality Sensor 24 Vac Source
ACT 2-10	2-10 Vdc	Damper Actuator Output (2-10 Vdc)
ACT COM	COM	Damper Actuator Output Common
ACT 24V	24 Vac	Damper Actuator 24 Vac Source

**Table 4 – Economizer Module - Right Hand Terminal Blocks**

Label	Type	Description
<b>Top Right Terminal Block</b>		
	n/a	The first terminal is not used
AUX2 I	24 Vac IN	Shut Down (SD) or Heat (W) Conventional only or Heat Pump Changeover (O?B) in Heat Pump mode.
OCC	24 Vac IN	Occupied / Unoccupied Input
E-GND	E-GND	Earth Ground – System Required
EXH1	24 Vac OUT	Exhaust Fan 1 Output
AUX1 O	24 Vac OUT	Programmable: Exhaust fan 2 output or Erv or System Alarm output
<b>Bottom Right Terminal Block</b>		
Y2-I	24 Vac IN	Y2 in – Cooling Stage 2 Input from space thermostat
Y2-O	24 Vac OUT	Y2 out – Cooling Stage 2 Output to stage 2 mechanical cooling
Y1-I	24 Vac IN	Y1 in – Cooling Stage 2 Input from space thermostat
Y1-O	24 Vac OUT	Y1 out – Cooling Stage 2 Output to stage 2 mechanical cooling
C	COM	24 Vac Common
R	24 Vac	24 Vac Power (Hot)

### Time-out and Screen Saver

When no buttons have been pressed for 10 minutes, the LCD displays a screen saver, which cycles through the Status items. Each Status item displays in turn and cycles to the next item after 5 seconds.

LLECON-01SI

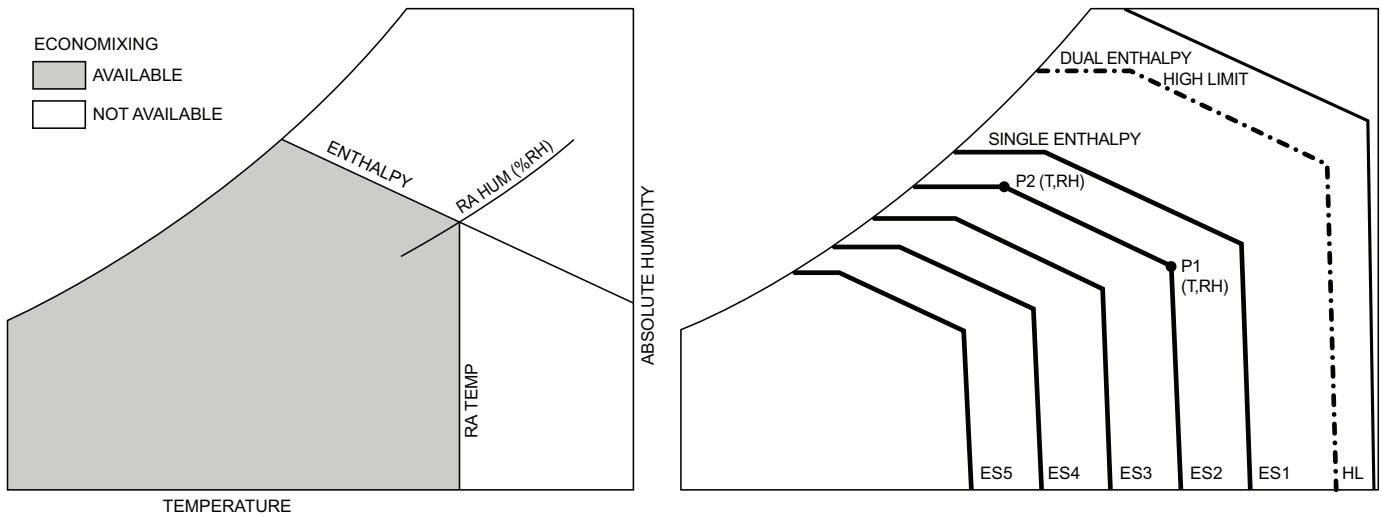

C12015

**Fig. 4 - Single Enthalpy Curve and Boundaries**

**Table 5 – Single Enthalpy and Dual Enthalpy High Limit Curves**

Enthalpy Curve	Temp. Dry-Bulb (°F)	Temp. Dewpoint (°F)	Enthalpy (btu/lb/da)	Point P1		Point P2	
				Temp. (°F)	Humidity %RH	Temp. (°F)	Humidity %RH
ES1	80.0	60.0	28.0	80.0	36.8	66.3	80.1
ES2	75.0	57.0	26.0	75.0	39.6	63.3	80.0
ES3	70.0	54.0	24.0	70.0	42.3	59.7	81.4
ES4	65.0	51.0	22.0	65.0	44.8	55.7	84.2
ES5	60.0	48.0	20.0	60.0	46.9	51.3	88.5
HL	86.0	66.0	32.4	86.0	38.9	72.4	80.3

### Enthalpy Settings

When the OA temperature, enthalpy and dew point are below the respective setpoints, the Outdoor Air can be used for economizing. Fig. 4 shows the new single enthalpy boundaries in the W7220. There are 5 boundaries (setpoints ES1 through ES5), which are defined by dry bulb temperature, enthalpy and dew point.

Refer to Table 5 for ENTH CURVE setpoint values.

To use enthalpy the W7220 must have a HH57A081 enthalpy control sensor for OA. The W7220 calculates the enthalpy and dew point using the OA temperature and humidity input from the OA sensor. When the OA temperature, OA humidity and OA dew point are all below the selected boundary, the economizer sets the economizing mode to YES, economizing is available.

When all of the OA conditions are above the selected boundary, the conditions are not good to economize and the mode is set to NO.

Fig. 4 shows the 5 current boundaries. There is also a high limit boundary for differential enthalpy. The high limit boundary is ES1 when there are no stages of mechanical cooling energized and HL (high limit) when a compressor stage is energized.

Table 5 provided the values for each boundary limit.

### Enthalpy Control Sensor Configuration

The Enthalpy Control sensor (Part Number: HH57AC081) communicates with the W7220 Economizer controller on the two-wire communications bus and can either be wired using a two pin header or using a side connector. This sensor is used for all OAT (Outdoor Air Temperature), RAT (Return Air Temperature) and DAT (Discharge Air Temperature), depending on how its three position DIP switch is set.

Use Fig. 5 and Table 6 to locate the wiring terminals for each Enthalpy Control sensor.

Use Fig. 5 and Table 7 to set the DIP switches for the desired use of the sensor.

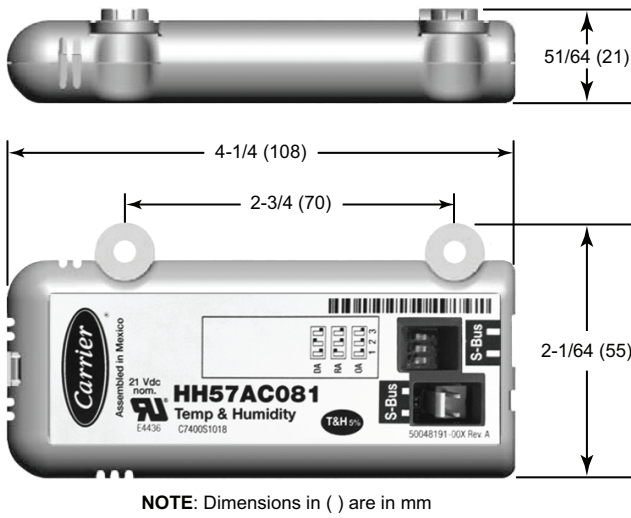

NOTE: Dimensions in ( ) are in mm

C12036

**Fig. 5 - Enthalpy Control Sensor, Dimensions and DIP Switch Location**

**Table 6 – Enthalpy Control Sensor Wiring Terminations<sup>a</sup>**

Terminal		Type	Description
Nbr	Label		
1	S-BUS	S-BUS	S-Bus Communications (Enthalpy Control Sensor Bus)
2	S-BUS	S-BUS	S-Bus Communications (Enthalpy Control Sensor Bus)

<sup>a</sup> Terminals are polarity insensitive.

**Table 7 – Enthalpy Control Sensor DIP Switch Settings**

Use	DIP Switch Positions for Switches 1, 2, & 3		
	1	2	3
DA <sup>a</sup>	OFF	ON	OFF
RA <sup>b</sup>	ON	OFF	OFF
OA <sup>c</sup>	OFF	OFF	OFF

<sup>a</sup> DA = Discharge Air

<sup>b</sup> RA = Return Air

<sup>c</sup> OA = Outside Air

### Install Outside Air Hood — Factory Option

The outside air hood for factory-option economizer is shipped in knock-down form and requires field assembly. See the base unit Installation Instructions for details on assembling and attaching the outside air hood.

### 15 to 25 Ton Horizontal Return Application with Barometric Relief

If barometric relief is required remove the relief damper and hinges from the (provided) bottom panel used on vertical applications. Reinstall the hinges and damper on the side of the field supplied return duct. (see Fig. 6)

**NOTE:** A relief hood for horizontal application can be ordered separately (part number CRBARHOD001A00) or can be field-supplied.

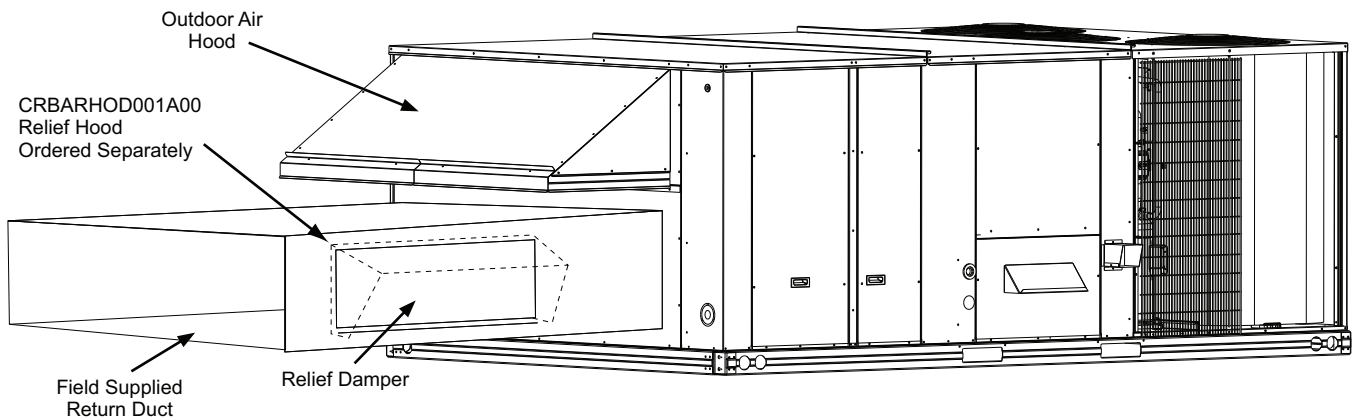

**Fig. 6 - Reinstall Hinges and Damper on Return Duct**

C09343

LLECON-01SI

# OPERATION

## Cooling, Unit With EconoMi\$er X

For Occupied mode operation of EconoMi\$er X, there must be a 24-v signal at terminals R and OCC (provided through PL6-3 from the unit's IFC coil). Removing the signal at OCC places the EconoMi\$er X control in Unoccupied mode.

During Occupied mode operation, indoor fan operation will be accompanied by economizer dampers moving to Minimum Position setpoint for ventilation. If indoor fan is off, dampers will close. During Unoccupied mode operation, dampers will remain closed unless a Cooling (by free cooling) or DCV demand is received.

When free cooling using outside air is not available, the unit cooling sequence will be controlled directly by the space thermostat. Outside air damper position will be closed or Minimum Position as determined by occupancy mode and fan signal.

When free cooling is available as determined by the appropriate changeover command (dry bulb, outdoor enthalpy, differential dry bulb or differential enthalpy), a call for cooling (Y1 closes at the thermostat) will cause the economizer control to modulate the dampers open and closed to maintain the unit supply air temperature at 50 to 55°F. Compressor will not run.

During free cooling operation, a supply air temperature (SAT) above 50°F will cause the dampers to modulate between Minimum Position setpoint and 100% open. With SAT from 50°F to 45°F, the dampers will maintain at the Minimum Position setting. With SAT below 45°F, the outside air dampers will be closed. When SAT rises to 48°F, the dampers will re-open to Minimum Position setting.

Should 100% outside air not be capable of satisfying the space temperature, space temperature will rise until Y2 is closed. The economizer control will call for compressor operation. Dampers will modulate to maintain SAT at 50 to 55°F concurrent with Compressor 1 operation. The Low Ambient Lockout Thermostat will block compressor

operation with economizer operation below 42°F outside air temperature.

When space temperature demand is satisfied (thermostat Y1 opens), the dampers will return to Minimum Damper position if indoor fan is running or fully closed if fan is off.

If accessory power exhaust is installed, the power exhaust fan motors will be energized by the economizer control as the dampers open above the EXH1 SET setpoint and will be de-energized as the dampers close below the EXH1 SET setpoint.

Damper movement from full closed to full open (or vice versa) will take between 1-1/2 and 2-1/2 minutes.

## Heating With EconoMi\$er X

During Occupied mode operation, indoor fan operation will be accompanied by economizer dampers moving to Minimum Position setpoint for ventilation. If indoor fan is off, dampers will close. During Unoccupied mode operation, dampers will remain closed unless a DCV demand is received.

When the room temperature calls for heat (W1 closes), the heating controls are energized.

## Demand Controlled Ventilation

If a field-installed CO<sub>2</sub> sensor is connected to the EconoMi\$er X control, a Demand Controlled Ventilation strategy will operate automatically. As the CO<sub>2</sub> level in the space increases above the setpoint (on the EconoMi\$er X controller), the minimum position of the dampers will be increased proportionally, until the Maximum Ventilation setting is reached. As the space CO<sub>2</sub> level decreases because of the increase in fresh air, the outdoor-damper will follow the higher demand condition from the DCV mode or from the free-cooling mode.

DCV operation is available in Occupied and Unoccupied periods with EconoMi\$er X. However, a control modification will be required on the 48TC units to implement the Unoccupied period function.

**Table 8 – Damper Position Control, 2-Speed Fan Motor, Economizer Cooling Not Available**

<b>INPUT</b>					
OCC	0-V	24-V	24-V	24-V	24-V
Y1	0-V	0-V	24-V	24-V	0-V
Y2	0-V	0-V	0-V	24-V	0-V
W1	0-V	0-V	0-V	0-V	24-V
<b>SUPPLY FAN MOTOR SPEED</b>	OFF	LOW	LOW	HIGH	HIGH
<b>DAMPER POSITION</b>					
NO CO2 SENSOR	CLOSED	MIN POS	MIN POS	MIN POS	MIN POS
W/CO2 SENSOR	CLOSED	FROM VENTMIN L TO VENTMAX L	FROM VENTMIN L TO VENTMAX L	FROM VENTMIN H TO VENTMAX H	FROM VENTMIN H TO VENTMAX H

# TROUBLESHOOTING

## Power Loss (Outage or Brownout)

All setpoints and advanced settings are restored after any power loss or interruption, as all settings are stored in the Economizer controller's non-volatile flash memory.

**NOTE:** If the power goes below 18 Vac, the W7220 controller module assumes a power loss and the 5 minute power up delay will become functional when power returns above 18 Vac.

## Alarms

The Economizer module provides alarm messages that display on the 2-line LCD.

**NOTE:** Upon power up, the module waits several seconds before checking for alarms. This allows time for all the configured devices (e.g. sensors, actuator) to become operational.

If one or more alarms are present and there has been no keypad activity for at least 5 minutes, the Alarms menu displays and cycles through the active alarms.

You can also navigate to the Alarms menus at any time. See Table 2 on page 6 for the Alarms menu.

## Clearing Alarms

Once the alarm has been identified and the cause has been removed (e.g. replaced faulty sensor), the alarm can be cleared from the display.

To clear an alarm, perform the following:

1. Navigate to the desired alarm.
2. Press the **↵** button.
3. ERASE? displays.
4. Press the **↵** button.
5. ALARM ERASED displays.
6. Press the **⏮** (Menu up/Exit) button to complete the action and return to the previous menu.

**NOTE:** If the alarm still exists after you clear it, it is redisplayed within 5 seconds.

LLECON-01SI

**Table 9 – Operating Issues and Concerns**

Issue or Concern	Possible Cause and Remedy
My outdoor temperature reading on the STATUS menu is not accurate.	Check the sensor wiring: <ul style="list-style-type: none"> <li>• Enthalpy sensors are to be wired to the S-Bus terminals.</li> <li>• Temperature sensors are to be wired to the OAT and MAT terminals.</li> </ul>
If my enthalpy sensor drifts in accuracy over time, can I re-calibrate it?	The sensor are not able to be re-calibrated in the field. However there is a menu item under the ADVANCED menu where you are able to input a limited offset in temperature and humidity for each sensor you have connected to the economizer.
Can I go back to factory defaults and start over?	Under the SYSTEM SETUP menu you can change the setpoints to the factory defaults.
Will I be able to see the LCD screen when it is in the unit?	The LCD screen has a backlight that is always illuminated.
What is a good setpoint for the Mixed Air Temperature (MAT)?	The mixed air temperature is the temperature of air that you want to supply to the space. In a commercial building, this is between 50 to 55°F (10 to 13°C). The mixed air is the mixing of the return air and the outdoor air.
I am using enthalpy sensors. Why did the control ask me to input a dry bulb changeover temperature?	In the event the humidity sensor in the enthalpy sensors fails, the backup algorithm in the control is to default to the temperature sensor in the enthalpy sensor.
In checkout, the outdoor damper closes when i command it to open.	Check the actuator linkage or rotation. In the CHECKOUT mode, the outdoor damper should drive open or closed with the return air damper having the opposite effect.
How do I set my minimum position?	The minimum position is set using the VENTMIN and VENTMAX setup in the SETPOINTS menu. VENTMIN is the minimum ventilation required when using an occupancy sensor and VENTMAX is the minimum ventilation when not using an occupancy sensor for Demand Control Ventilation. The VENTMAX position is set the same as with the potentiometer on the analog economizers and is the output voltage to the damper actuator. The range is 2 Vdc closed OA damper and 10 Vdc open OA damper.
What if my damper does not go completely closed in the checkout operation?	Check the damper linkage or hub to make sure the damper is able to close completely.
How do I set the OCC?	There are two setting for the OCC setting, INPUT and ALWAYS. INPUT is from the space thermostat, if it has an occupancy output. ALWAYS is the unit in the occupied mode, if the economizer is powered (fan on).
Does the economizer save my program values if the unit loses power?	Yes, once the changes are stored in the controller they will be stored until they are changed by the operator.
If the unit is left in checkout, how long will the unit stay in checkout mode without input?	The unit will remain in checkout for 10 minutes, then return to normal operation.

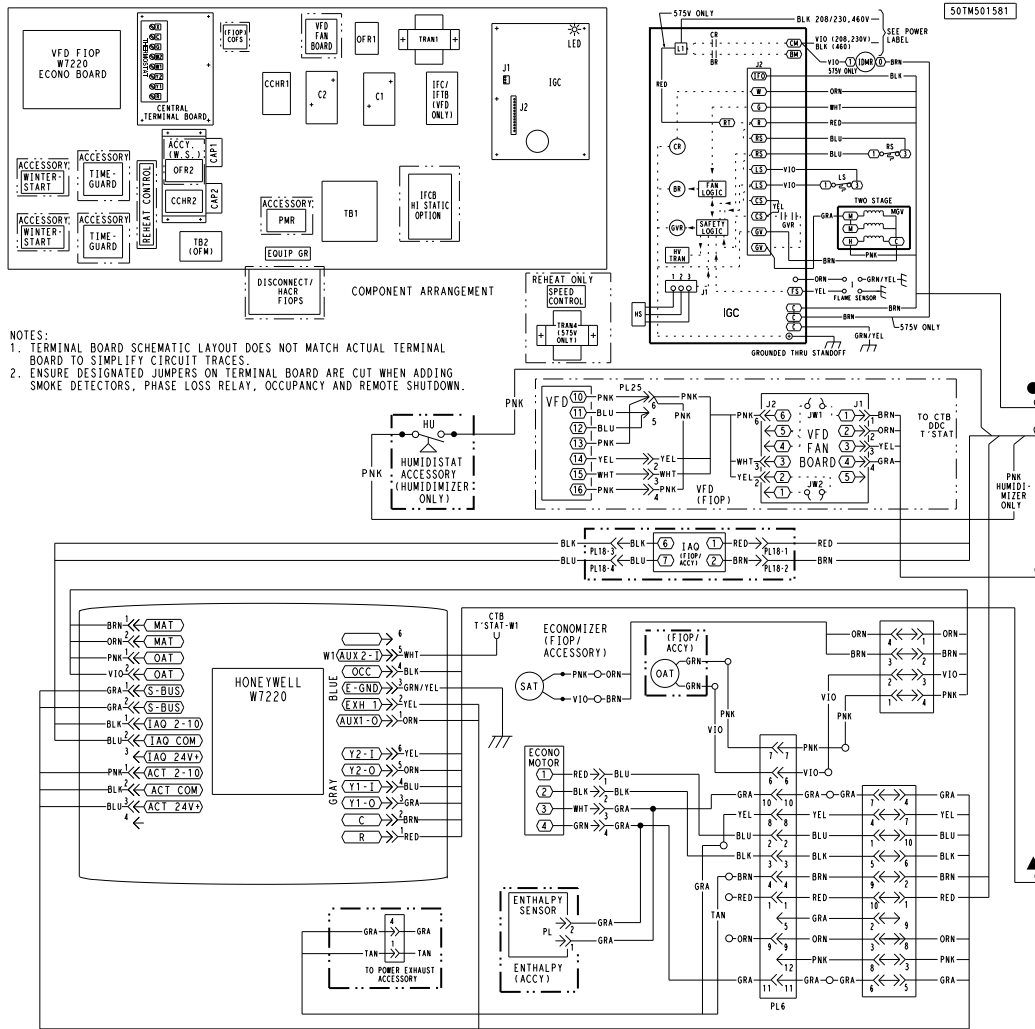

Fig. 7 - Typical Economizer X Wiring Diagram

C11549