

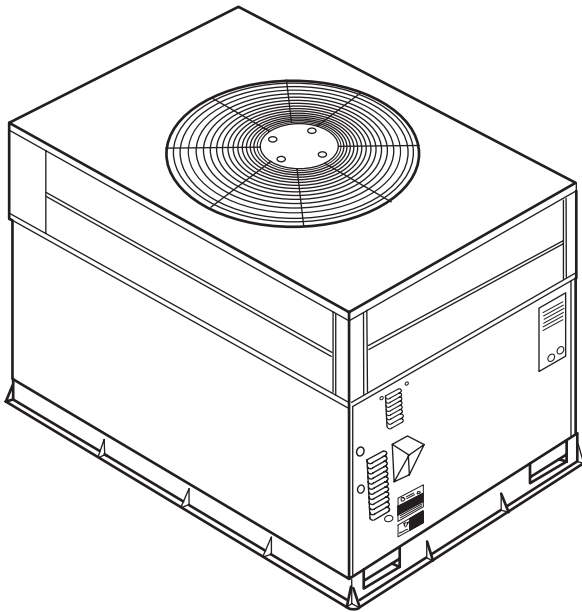

PY3P
13 SEER SINGLE-PACKAGED AIR CONDITIONER
AND GAS FURNACE SYSTEM W/R-22 REFRIGERANT
1 AND 3 PHASE
1-1/2 TO 5 NOMINAL TONS (SIZES 018-060)

Product Data



A06079

Fig. 1 - Unit PY3P

Single-Packaged Rooftop Products with Energy-Saving Features.

- Direct Spark Ignition
- Low Sound Levels
- Up to 81% AFUE
- 13 SEER

FEATURES/BENEFITS

One-piece heating and cooling units with low sound levels, easy installation, low maintenance, and dependable performance.

Easy Installation

Factory-assembled package is a compact, fully self-contained, combination gas heating/electric cooling unit that is pre-wired, pre-piped, and pre-charged for minimum installation expense.

These units are available in a variety of standard and optional heating/cooling size combinations with voltage options to meet residential and light commercial requirements. Units are lightweight and install easily on a rooftop or at ground level. The high-tech composite basepan eliminates rust problems associated with ground level applications.

Convertible duct configuration

Unit is designed for easy use in either downflow or horizontal applications. Each unit is easily converted from horizontal to downflow with the use of the two standard duct covers.

Efficient operation

High-efficiency design with SEERs (Seasonal Energy Efficiency Ratios) of 13.0 and AFUE (Annual Fuel Utilization Efficiency) ratings as high as 81%.

Energy-saving, direct spark ignition saves gas by operating only when the room thermostat calls for heating. Standard units are furnished with natural gas controls. A low-cost field-installed kit for propane conversion is available for all units.

Low NOx units are designed for California installations. These models meet the Californian maximum oxides of nitrogen (NOx) emissions requirement of 40 nanograms/joule or less as shipped from the factory and **MUST** be installed in California Air Quality Management Districts where a Low NOx rule exists.

Durable, dependable components

Compressors are designed for high efficiency. Each compressor is hermetically sealed against contamination to help promote longer life and dependable operation. Each compressor also has vibration isolation to provide quieter operation. All compressors have internal high pressure and overcurrent protection.

Monoport inshot burners produce precise air-to-gas mixture, which provides for clean and efficient combustion. The large monoport on the inshot (or injection type) burners seldom, if ever, requires cleaning. All gas furnace components are accessible in one compartment.

Turbo-tubular™ heat exchangers are constructed of aluminized steel for corrosion resistance and optimum heat transfer for improved efficiency. The tubular design permits hot gases to make multiple passes across the path of the supply air.

In addition, dimples located on the heat exchanger walls force the hot gases to stay in close contact with the walls, improving heat transfer.

Direct-drive multi-speed, PSC (permanent split capacitor) blower motor is standard on all PY3P models.

Direct-drive, PSC condenser-fan motors are designed to help reduce energy consumption and provide for cooling operation down to 40°F (4°C) outdoor temperature. Motormaster® II low ambient kit is available as a field-installed accessory and does not require a special motor.

Corporate thermostats include the Time Guard® II anti-short cycle protection circuitry. If an Original Equipment Manufacturer (OEM) thermostat is used the Time Guard II field installed anti-short cycle kit must be used.

Refrigerant system is designed to provide dependability. Liquid refrigerant strainers are used to promote clean, unrestricted operation. Each unit leaves the factory with a full refrigerant charge. Refrigerant service connections make checking operating pressures easier.

Evaporator and condenser coils are computer-designed for optimum heat transfer and cooling efficiency. The evaporator coil is fabricated from copper tube and aluminum fins and is located

inside the unit for protection against damage. The condenser coil is internally mounted on the top tier of the unit. A FIOP (Factory-Installed Option) metal louvered grille is available on all models. Copper fin coils and pre-coated fin coils are available from the factory by special order. These coils are recommended in applications where aluminum fins are likely to be damaged due to corrosion. They are ideal for seacoast applications.

Low sound ratings ensure a quiet indoor and outdoor environment with sound ratings as low as 72dBA. (See page 3.)

Easy to service cabinets provide easy single-panel accessibility to serviceable components during maintenance and installation. The basepan with integrated drain provides easy ground level installation with or without a mounting pad. Convenient handholds are provided to manipulate the unit on the jobsite. A nesting feature ensures a positive basepan to roof curb seal when the unit is roof mounted. A convenient 3/4-in. (19 mm) wide perimeter flange makes frame mounting on a rooftop easy.

Downflow operation is easily provided in the field to allow vertical ductwork connections. The basepan utilizes knockout style seals on the bottom openings to ensure a positive seal in the horizontal airflow mode.

Integrated Gas Control (IGC) board provides safe and efficient control of heating and simplifies trouble-shooting through its built-in diagnostic function.

Cabinets are constructed of heavy-duty, phosphated, zinc-coated prepainted steel capable of withstanding 500 hours in salt spray. Interior surfaces of the evaporator/heat exchanger compartment are insulated with cleanable semi-rigid insulation board, which keeps the conditioned air from being affected by the outdoor ambient temperature and provides improved indoor air quality. (Conforms to American Society of Heating, Refrigeration and Air Conditioning Engineers No. 62P.) The sloped drain minimizes standing water in the drains which is provided with an external drain.

MODEL NUMBER NOMENCLATURE

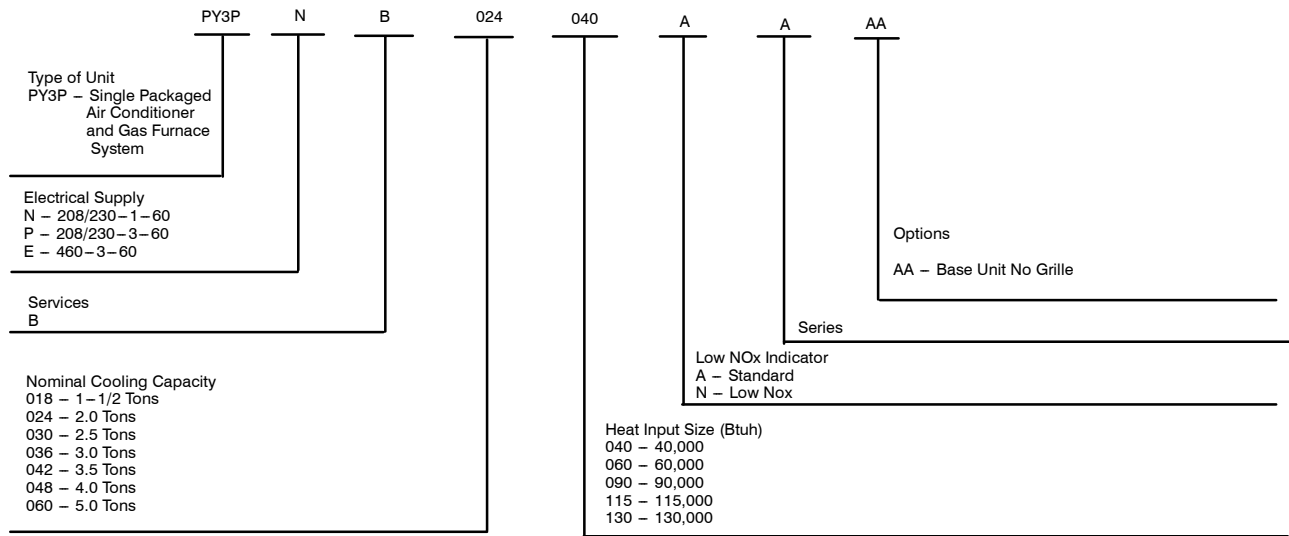

ARI* CAPACITIES

Cooling Capacities and Efficiencies

UNIT PY3P	NOMINAL TONS	STANDARD CFM	NET COOLING CAPACITIES (Btuh)	SEER†
018040	1-1/2	600	17,200	13.0
024040 024060	2	800	22,600	13.0
030040 030060	2-1/2	1000	28,000	13.0
036060 036090	3	1200	35,000	13.0
042060 042090	3-1/2	1400	40,000	13.0
048090 048115 048130	4	1600	47,000	13.0
060090 060115 060130	5	1750	57,500	13.0

LEGEND

db—Dry Bulb

wb—Wet Bulb

SEER—Seasonal Energy Efficiency Ratio

* Air Conditioning & Refrigeration Institute.

† Rated in accordance with U.S. Government DOE Department of Energy) test procedures and/or ARI Standards 210/240–89.

‡ Tested in accordance with ARI Standard 270–95 (not listed in ARI).

Notes:

1. Ratings are net values, reflecting the effects of circulating fan heat. Ratings are based on:

Cooling Standard: 80°F (26°C) db, 67°F (19°C) wb indoor entering –air temperature and 95°F (35°C) db outdoor entering–air temperature.

2. Before purchasing this appliance, read important energy cost and efficiency information available from your retailer.

PY3P

Gas Heating Capacities and Efficiencies

UNIT PY3P	HEATING INPUT (Btuh)	OUTPUT CAPACITY (Btuh)	TEMPERATURE RISE RANGE (°F)	AFUE (%)
018040	40,000	32,000 31,000 (Low NOx)	30–60	79.7 79.2 (Low NOx)
024040 030040	40,000	32,000	20–50	80.1
024060 030060 036060 042060	60,000	47,000	35–65 35–65 25–55 25–55	78.4 78.4 78.7 78.7
036090 042090 048090 060090	90,000 90,000 90,000 90,000	72,000 72,000 71,000 71,000	40–70 40–70 25–55 25–55	79.9 79.9 78.5 78.6
048115 060115	115,000	93,000 90,000 (Low NOx)	35–65	81.1 78.3 (Low NOx)
048130 060130	130,000	104,000	40–70	80.3

LEGEND

AFUE—Annual Fuel Utilization Efficiency

NOTE: Before purchasing this appliance, read important energy cost and efficiency information available from your retailer.

ISO 9001:2000



Outdoor Sound Power

UNIT	PY3P						
	018	024	030	036	042	048	060
Frequency (Hz)							
Sound Ratings (dBA)	72	72	72	72	73	78	78
125	54.5	54.1	47.3	56.4	56.9	64.0	64.1
250	60.5	57.1	58.2	61.0	64.0	69.9	66.6
500	64.0	64.9	63.2	67.4	68.0	73.3	70.6
1000	66.5	67.6	66.1	68.1	67.7	73.5	72.6
2000	62.5	64.1	64.0	65.8	64.6	70.4	69.8
4000	58.5	59.7	61.3	64.8	61.3	66.7	67.5
8000	52.5	53.5	57.0	56.8	55.5	60.5	61.6

LEGEND

Sound Levels (10 decibels=1 bel)

PHYSICAL DATA

UNIT SIZE PY3P	018040	024040	024060	030040	030060	036060	036090	042060	042090
NOMINAL CAPACITY (ton)	1.5	2	2	2-1/2	2-1/2	3	3	3-1/2	3-1/2
OPERATING WEIGHT (lb) (kg)	290 132	343 156	343 156	355 156	355 156	360 163	360 163	450 204	450 204
COMPRESSORS	Scroll								
REFRIGERANT (R-22) Quantity (lb) (kg)	5.3 2.4	5.9 2.7	5.9 2.7	6.0 2.7	6.0 2.7	7.2 3.3	7.2 3.3	7.8 3.5	7.8 3.5
REFRIGERANT METERING DEVICE Orifice ID (in.)	TXV NA	AccuRater 0.065 0.065 0.070 0.070 0.080 0.080 0.084 0.084							
CONDENSER COIL Rows—Fins/in. Face Area (sq ft)	1...21 13.6	2...21 10.2	2...21 10.2	2...21 11.9	2...21 11.9	2...21 113.6	2...21 13.6	2...21 19.4	2...21 19.4
CONDENSER FAN Nominal Cfm Diameter (in.) Motor Hp (Rpm)	2200 22 1/8 (825)	2200 22 1/8 (825)	2200 22 1/8 (825)	2800 22 1/8 (825)	2800 22 1/8 (825)	3000 22 1/8 (825)	3000 22 1/8 (825)	3500 22 1/8 (825)	3500 22 1/8 (825)
EVAPORATOR COIL Rows—Fins/in. Face Area (sq ft)	3...17 3.7	3...17 3.7	3...17 3.7	3...17 3.7	3...17 3.7	4...17 3.7	4...17 3.7	3...17 4.7	3...17 4.7
EVAPORATOR BLOWER Nominal Airflow (Cfm) Size (in.) Size (mm) Motor Hp (RPM)	600 10x10 254x254 1/4 (825)	800 10x10 254x254 1/3 (1050)	800 10x10 254x254 1/3 (1050)	1000 10x10 254x254 1/3 (1050)	1000 10x10 254x254 1/3 (1050)	1200 10x10 254x254 1/2 (1000)	1200 10x10 254x254 1/2 (1000)	1400 11x10 279x254 1/2 (1075)	1400 11x10 279x254 1/2 (1075)
FURNACE SECTION* Burner Orifice No. (Qty—Drill Size) Natural Gas Burner Orifice No. (Qty—Drill Size) Propane	2...44 2...50	2...44 2...50	2...38 2...46	2...44 2...50	2...38 2...46	2...38 2...46	3...38 3...46	2...38 2...46	3...38 3...46
RETURN-AIR FILTERS Throwaway (in.)† (mm)	20x20x1 508x508x25		20x24x1 508x610x25			24x30x1 610x762x25			

UNIT SIZE PY3P	048090	048115	048130	060090	060115	060130
NOMINAL CAPACITY (ton)	4	4	4	5	5	5
OPERATING WEIGHT (lb) (kg)	480 218	480 218	480 218	484 220	484 220	484 220
COMPRESSORS	Scroll					
REFRIGERANT (R-22) Quantity (lb) (kg)	12.4 5.6	12.4 5.6	12.4 5.6	12.0 5.4	12.0 5.4	12.0 5.4
REFRIGERANT METERING DEVICE Orifice ID (in.)	AccuRater 0.088 0.088 0.088 0.098 0.098 0.098					
CONDENSER COIL Rows—Fins/in. Face Area (sq ft)	2...21 19.4	2...21 19.4	2...21 19.4	2...21 19.4	2...21 19.4	2...21 19.4
CONDENSER FAN Nominal Cfm Diameter (in.) Motor Hp (Rpm)	3500 22 1/4 (1100)	3500 22 1/4 (1100)	3500 22 1/4 (1100)	4200 22 1/4 (1100)	4200 22 1/4 (1100)	4200 22 1/4 (1100)
EVAPORATOR COIL Rows—Fins/in. Face Area (sq ft)	3...17 5.7	3...17 5.7	3...17 5.7	4...17 5.7	4...17 5.7	4...17 5.7
EVAPORATOR BLOWER Nominal Airflow (Cfm) Size (in.) Size (mm) Motor Hp (RPM)	1600 11x10 279x254 1/2 (1075)	1600 11x10 279x254 1/2 (1075)	1600 11x10 279x254 1/2 (1075)	1750 11x10 279x254 1 (1040)	1750 11x10 279x254 1 (1040)	1750 11x10 279x254 1 (1040)
FURNACE SECTION* Burner Orifice No. (Qty—Drill Size) Natural Gas Burner Orifice No. (Qty—Drill Size) Liquid Propane	3...38 3...46	3...33 3...42	3...31 3...41	3...38 3...46	3...33 3...42	3...31 3...41
RETURN-AIR FILTERS Throwaway (in.)† (mm)	24x36x1 610x914x25					

LEGEND

* Based on altitude of 0 to 2000 feet (0 to 610 m).

† Required filter sizes on shown are based on the larger of the ARI (Air Conditioning and Refrigeration Institute) rated cooling airflow or the heating airflow velocity of 300 ft/min for throwaway type or 450 ft/min for high-capacity type. Air filter pressure drop for non-standard filters must not exceed 0.08 IN. W.C..

PY3P

OPTIONS AND ACCESSORIES

Factory-Installed Options

Coil options include copper/copper and vinyl-coated construction for refrigerant coils. Units are shipped standard with copper tube/aluminum fin construction. See model number nomenclature for coil options.

Field-installed accessories

Economizer with Solid-State Controls and Barometric Relief Dampers
Manual Air Damper (25% open)
Filter Rack
Flat Roof Curbs (8-in. (203 mm) and 14-in. (356 mm))
Square-to-Round Duct Transition Kit
Thermostats
Controls Upgrade Kit
Crankcase Heater
Compressor Hard Start Kit (for use on single-phase units only)
Natural-to-propane Gas Conversion Kit
High Altitude Propane Conversion Kit
Propane-to-natural Gas Conversion Kit
Rigging Kit
Low Ambient Kit (Motormaster® II Control)
Solid-State Time Guard® II Device

Economizer with solid-state controls and barometric relief dampers includes filter racks and provide outdoor air during cooling and reduce compressor operation.

Manual outside air damper includes hood and filter rack with adjustable damper blade for up to 25% outdoor air.

Flat roof curbs in both 8 in. (203 mm) and 14 in. (356 mm) sizes are available for roof mounted applications.

Square-to-round duct transition kit enables 018-048 size units to be fitted to 14 in. (356 mm) round ductwork.

Compressor hard start kit assists compressor start-up by providing additional starting torque on single phase units and prolongs compressor motor life.

Corporate Thermostats provide control for the system heating and cooling functions. Thermostat models are available in both programmable and non-programmable versions.

Controls upgrade kit supplies high and low pressure safety protection and protects the unit from operating in unsuitable conditions.

Crankcase heater provides anti-floodback protection for low-load cooling applications.

Natural-to-propane gas conversion kit allows for conversion from natural gas to propane gas for standard altitude (0 to 2000 ft above sea level) (0 to 610 m).

Rigging kit includes lifting brackets which are inserted into the unit base rigging holds to lift unit for rooftop applications.

Low-ambient kit (Motormaster II control) allows the use of mechanical cooling down to outdoor temperatures as low as 0°F (-17.8°C) when properly installed.

Solid-state Time Guard II device provides short-cycling protection for the compressor. Not required with corporate electronic thermostats.

Filter rack features easy installation, serviceability, and high-filtering performance for vertical applications.

High altitude propane conversion kit is for use at 2001 to 6000 ft (610 to 1829 m) above sea level. Kit consists of propane gas orifices that compensate for gas heat operation at high altitude.

Propane-to-natural conversion kit is for use at standard altitudes (0 to 2000 ft above sea level)(0 to 610 m). Kit contains natural gas orifices to convert the unit back to natural gas.

PY3P

ECONOMIZER

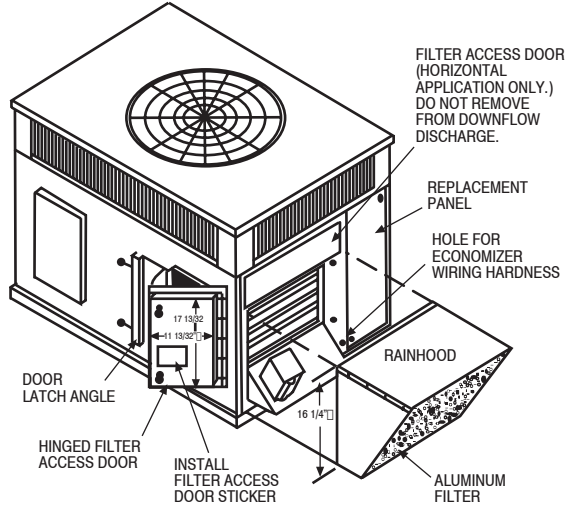
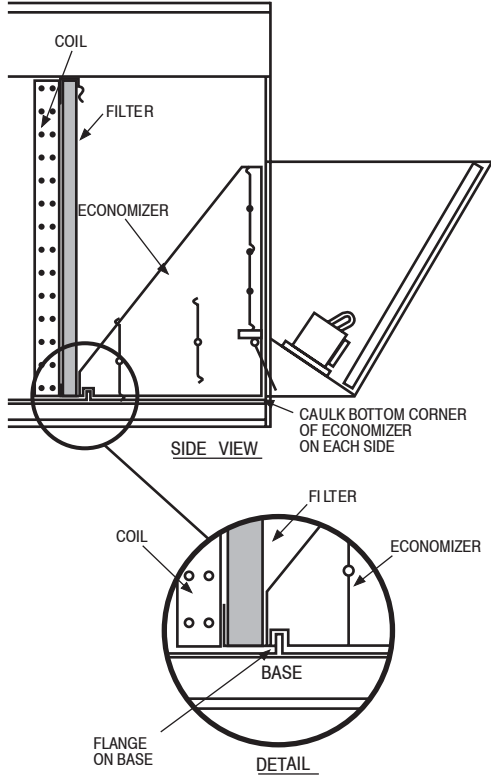

FILTER RACK

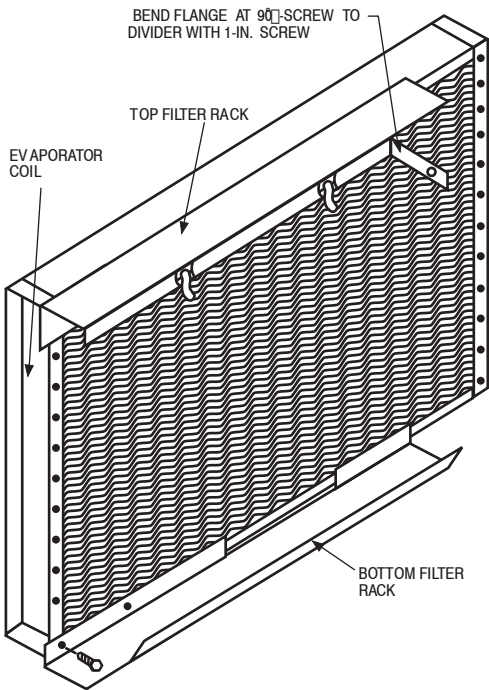

MANUAL OUTSIDE AIR DAMPER

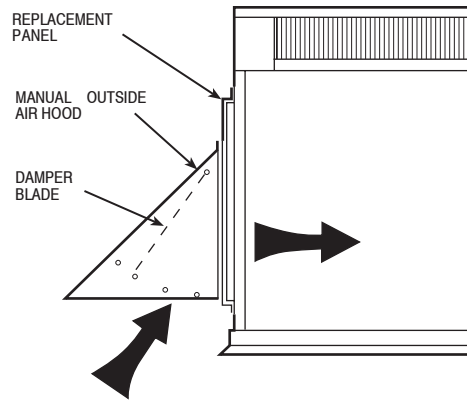

BASE UNIT DIMENSIONS—PY3P018-036

UNIT	ELECTRICAL CHARACTERISTICS		CENTER OF GRAVITY MM/IN			
	LB	KG	"A"	X	Y	Z
PY3P018040	290	131.5	1041.4(41.0)	591.8(23.3)	403.9(15.9)	393.7(15.5)
PY3P0200407060	343	156.0	940.3(37.0)	508.0(20.0)	431.8(17.0)	447.0(17.6)
PY3P0300407060	355	161.0	991.0(39.0)	508.0(20.0)	490.0(19.3)	330.0(13.0)
PY3P0360607090	360	163.0	1041.9(41.0)	533.0(21.0)	533.4(21.0)	422.0(16.6)

REQUIRED CLEARANCES TO COMBUSTIBLE MATL.

	MILLIMETERS (IN)
TOP OF UNIT	355.6 (14.00)
DUCT SIDE OF UNIT	50.8 (2.00)
SIDE OPPOSITE DUCTS	355.6 (14.00)
BOTTOM OF UNIT	0.00 (0.00)
FLUE PANEL	914.4 (36.00)

NEC. REQUIRED CLEARANCES.

	MILLIMETERS (IN)
BETWEEN UNITS, POWER ENTRY SIDE	1066.8 (42.00)
UNIT AND UNGROUNDED SURFACES, POWER ENTRY SIDE	914.0 (36.00)
UNIT AND BLOCK OR CONCRETE WALLS AND OTHER GROUNDED SURFACES, POWER ENTRY SIDE	1066.8 (42.00)

REQUIRED CLEARANCE FOR OPERATION AND SERVICING

	MILLIMETERS (IN)
EVAP. COIL ACCESS SIDE	914.0 (36.00)
POWER ENTRY SIDE	1066.8 (42.00)
(EXCEPT FOR NEC REQUIREMENTS)	1066.8 (42.00)
UNIT TOP	1219.2 (48.00)
SIDE OPPOSITE DUCTS	914.0 (36.00)
DUCT PANEL	304.8 (12.00)*

*MINIMUM DISTANCES: IF UNIT IS PLACED LESS THAN 304.8 (12.00) FROM WALL SYSTEM, THEN SYSTEM PERFORMANCE MAY BE COMPROMISED.

DIMENSIONS IN [] ARE IN INCHES

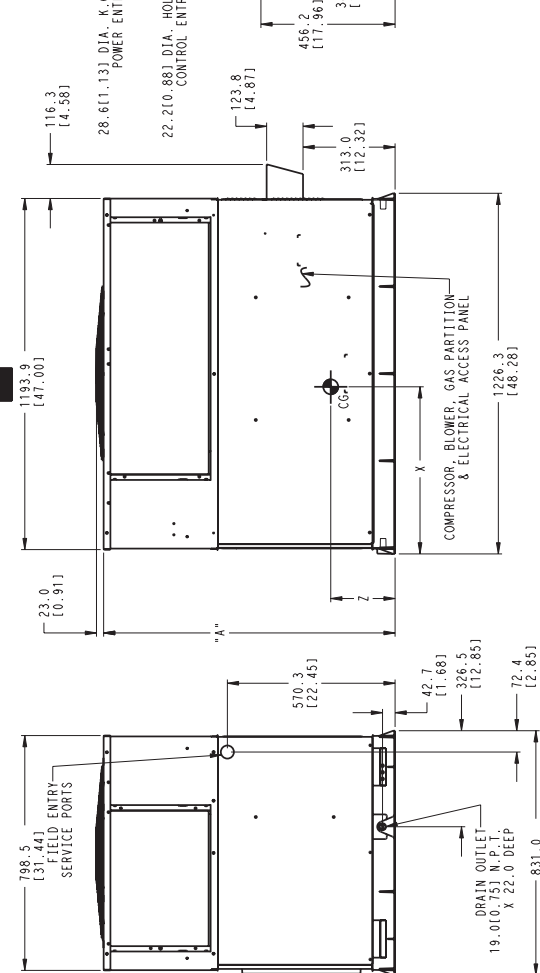
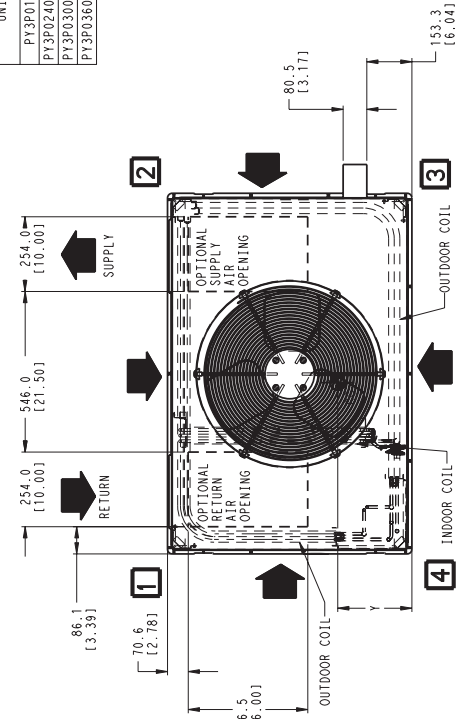

REV	5.0
48SD500036	

PY3P

BASE UNIT DIMENSIONS—PY3P042-060

PY3P

UNIT	ELECTRICAL CHARACTERISTICS		UNIT WT.		UNIT HEIGHT			CENTER OF GRAVITY MM/IN				
	208/230-T, 208/230-3, 460-3 60HZ	208/230-1, 208/230-3, 460-3 60HZ	LB	KG	"A"	"Y"	"Z"	X	Y	Z		
PY3P042060/090	208/230-T, 208/230-3, 460-3 60HZ	208/230-1, 208/230-3, 460-3 60HZ	450.0	[204.1]	1040.9	140.98	533.0	[21.0]	533.4	[21.0]	434.0	[17.1]
PY3P048090/115/130	208/230-T, 208/230-3, 460-3 60HZ	208/230-1, 208/230-3, 460-3 60HZ	480.0	[217.7]	1193.0	146.98	533.0	[21.0]	508.0	[20.0]	442.0	[17.4]
PY3P060090/115/130	208/230-T, 208/230-3, 460-3 60HZ	208/230-1, 208/230-3, 460-3 60HZ	484.0	[219.5]	1193.0	146.98	533.0	[21.0]	508.0	[20.0]	447.0	[17.6]

REQUIRED CLEARANCES TO COMBUSTIBLE MATL.

- TOP OF UNIT.....355.6 [14.00]
 DUCT SIDE OF UNIT.....50.8 [2.00]
 SIDE OPPOSITE DUCTS.....355.6 [14.00]
 BOTTOM OF UNIT.....0.00 [0.00]
 FLUE PANEL.....914.4 [36.00]
- NEC. REQUIRED CLEARANCES.**
- BETWEEN UNITS, POWER ENTRY SIDE.....1066.8 [42.00]
 UNIT AND UNGROUNDED SURFACES, POWER ENTRY SIDE.....914.0 [36.00]
 UNIT AND BLOCK OR CONCRETE WALLS AND OTHER GROUNDED SURFACES, POWER ENTRY SIDE.....1066.8 [42.00]
- REQUIRED CLEARANCE FOR OPERATION AND SERVICING**
- EVAP. COIL ACCESS SIDE.....914.0 [36.00]
 POWER ENTRY SIDE.....1066.8 [42.00]
 (EXCEPT FOR NEC REQUIREMENTS)
- UNIT TOP OPPOSITE DUCTS.....1219.2 [48.00]
 DUCT PANEL.....304.8 [12.00]
- MINIMUM DISTANCES: IF UNIT IS PLACED LESS THAN 304.8 [12.00] FROM WALL SYSTEM, THEN SYSTEM PERFORMANCE MAYBE COMPROMISED.

DIMENSIONS IN () ARE IN INCHES

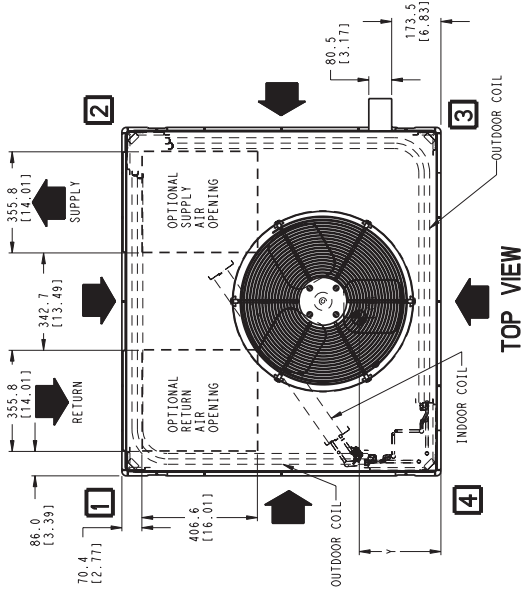

TOP VIEW

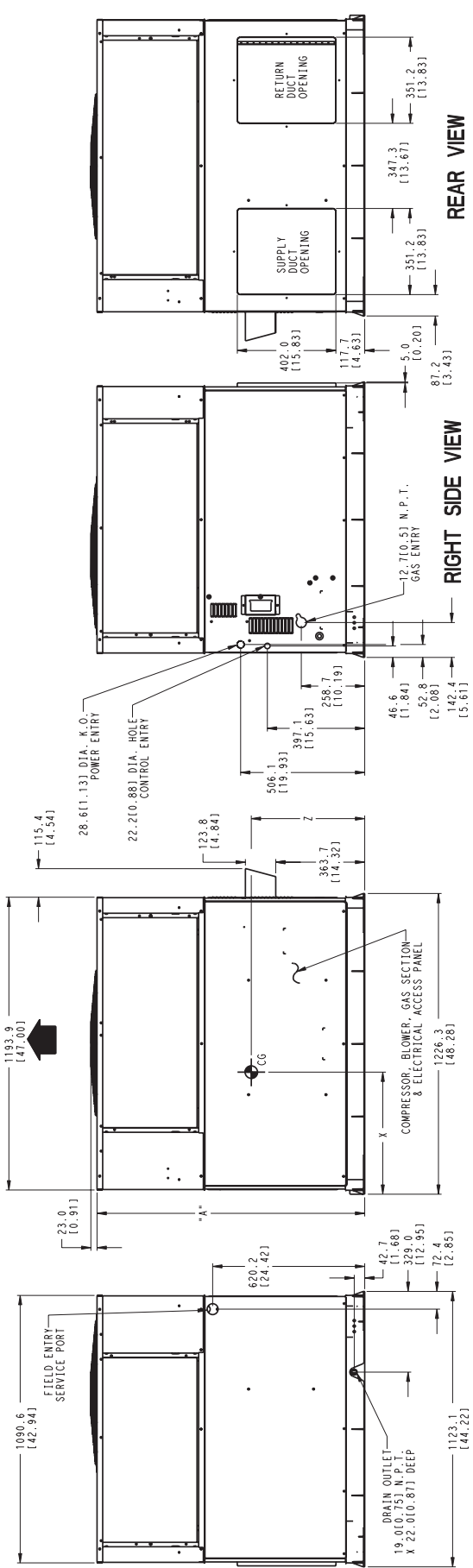

FRONT VIEW

LEFT SIDE VIEW

RIGHT SIDE VIEW

REAR VIEW

48SD500037 REV 4.0

ACCESSORY ROOF CURB

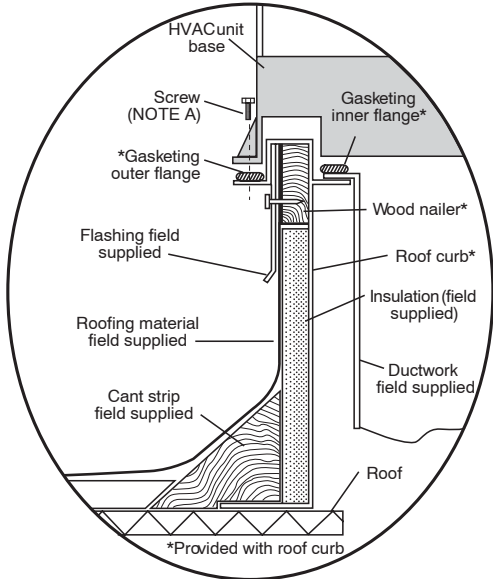

Roof Curb for Small Cabinet

Note A: When unit mounting screw is used, retainer bracket must also be used.

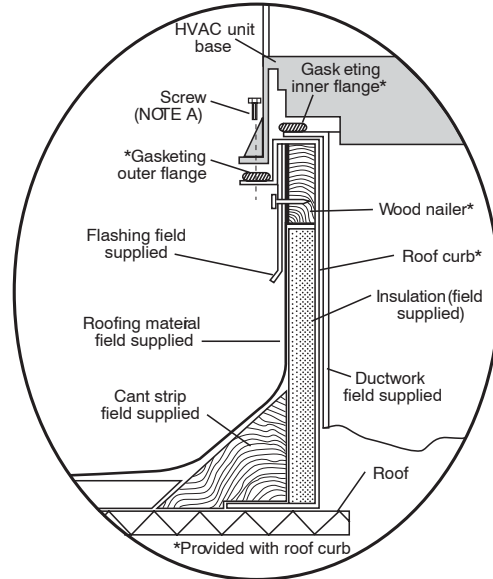

Roof Curb for Large Cabinet

Note A: When unit mounting screw is used, retainer bracket must also be used.

PY3P

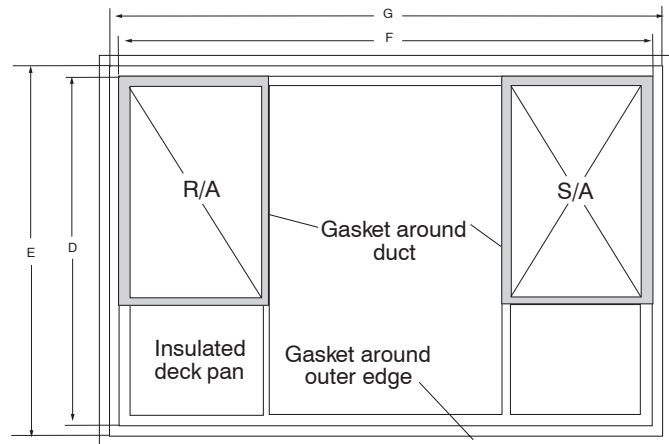
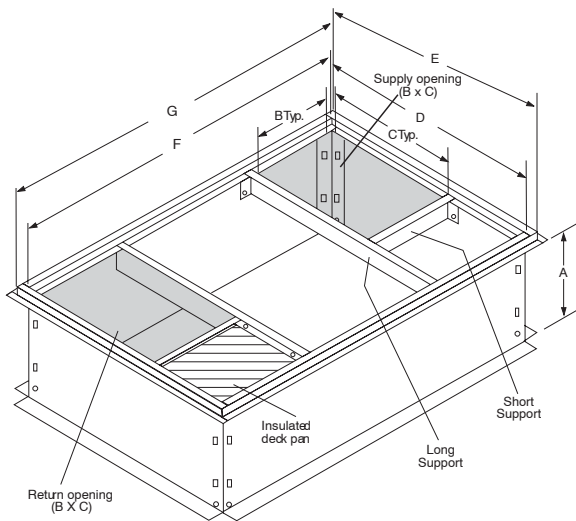

A05308

UNIT SIZE	ODS CATALOG NUMBER	A IN. (MM)	B IN. (MM)	C IN. (MM)	D IN. (MM)	E IN. (MM)	F IN. (MM)	G IN. (MM)
PY3P018-036	CPRFCURB006A00	8 (203)	11 (279)	16-1/2 (419)	28-3/4 (730)	30-3/8 (771)	44-5/16 (1126)	45-15/16 (1167)
	CPRFCURB007A00	14 (356)	11 (279)	16-1/2 (419)	28-3/4 (730)	30-3/8 (771)	44-5/16 (1126)	45-15/16 (1167)
PY3P042-060	CPRFCURB008A00	8 (203)	16-3/16 (411)	17-3/8 (441)	40-1/4 (1022)	41-15/16 (1065)	44-7/16 (1129)	46-1/16 (1169)
	CPRFCURB009A00	14 (356)	16-3/16 (411)	17-3/8 (441)	40-1/4 (1022)	41-15/16 (1065)	44-7/16 (1129)	46-1/16 (1169)

NOTES:

- Roof curb must be set up for unit being installed.
- Seal strip must be applied, as required, to unit being installed.
- Dimensions are in inches.
- Dimension in () are in millimeters.
- Roof curb is made of 16-gauge steel.
- Attach ductwork to curb (flanges of duct rest on curb).
- Insulated panels: 1-in. (25 mm) thick fiberglass 1 lb. density.
- When unit mounting screw is used (see Note A), a retainer bracket must be used as well. This bracket must also be used when required by code for hurricane or seismic conditions. This bracket is available through Micrometl.

PY3P CORNER WEIGHTS

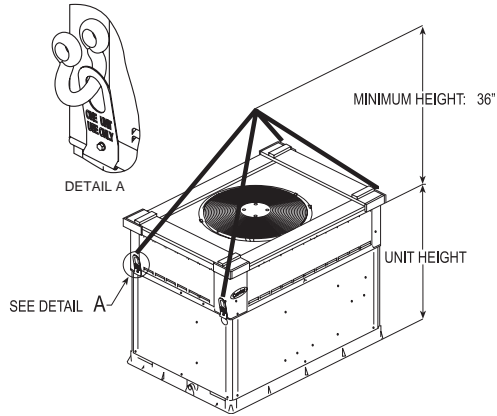
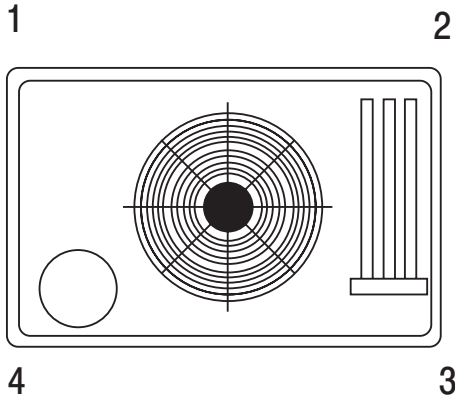

C00070B

A05161

PY3P

CORNER WEIGHTS (SMALL CABINET)									CORNER WEIGHTS (LARGE CABINET)						
Unit	018		024		030		036		Unit	042		048		060	
	lb	kg	lb	kg	lb	kg	lb	kg		lb	kg	lb	kg	lb	kg
Unit Only Weight	290	132	343	156	355	161	360	163	Unit Only Weight	450	204	480	218	484	220
Corner Weight 1	75	34	69	31	75	34	74	34	Corner Weight 1	90	41	97	44	98	45
Corner Weight 2	62	28	53	24	56	25	55	25	Corner Weight 2	72	33	74	34	75	34
Corner Weight 3	97	44	83	38	81	37	86	39	Corner Weight 3	110	50	116	53	118	54
Corner Weight 4	56	25	138	63	143	65	145	66	Corner Weight 4	178	81	193	88	193	88
Rigging Weight	309	140	353	160	365	166	370	168	Rigging Weight	465	211	495	225	499	226
Shipping Weight	344	156	383	173	395	179	400	181	Shipping Weight	510	231	540	245	544	247

SELECTION PROCEDURE (WITH EXAMPLE)

1. Determine cooling and heating requirements at design conditions:

Given:

- Required Cooling Capacity (TC) 34,000 Btuh
- Sensible Heat Capacity (SHC) 25,000 Btuh
- Required Heating Capacity 60,000 Btuh
- Condenser Entering Air Temperature 95°F (35°C)
- Indoor-Air Temperature 80°F (26°C) edb 67°F (19°C) ewb
- Evaporator Air Quantity 1200 CFM
- External Static Pressure 0.1 IN. W.C.
- Electrical Characteristics 208-1-60

2. Select unit based on required cooling capacity.

Enter Net Cooling Capacities table at outdoor entering temperature of 95°F (35°C). Unit PY3P036 at 1200 cfm and 67°F (19°C) ewb (entering wet bulb) will provide a total capacity of 36,000 Btuh and a SHC of 27,400 Btuh. Calculate SHC correction, if required, using Note 4 under Cooling Capacities tables.

3. Select heating capacity of unit to provide design condition requirement.

In the Heating Capacities and Efficiencies table on page 4, note that the unit PY3P036090 will provide 72,000 Btuh with an input of 90,000 Btuh.

4. Determine fan speed and power requirements at design conditions.

Before entering the air delivery tables, calculate the total static pressure required. From the given example, the Wet Coil Pressure Drop Table, and the Filter Pressure Drop table on page 16, find at 1200 cfm:

External Static Pressure	0.10 IN. W. C.
Wet Coil	0.059 IN. W.C.
Filter	<u>0.13 IN. W.C.</u>
Total Static Pressure	0.29 IN. W.C.

Enter the table for Dry Coil Air Delivery—horizontal and downflow Discharge on page 15. For 208 v operation, deduct 10% from the value given. At 0.33 ESP (external static pressure), the fan will deliver about 1404 cfm at medium speed. The fan speed should be set at medium speed.

5. Select unit that corresponds to power source available.

The Electrical Data table on page 21 shows that the unit is designed to operate at 208-1-60.

PERFORMANCE DATA

PY3P 018 Cooling Performance Table

EVAPORATOR AIR		CONDENSER ENTERING AIR TEMPERATURES deg F																							
CFM	EWB	75 (23°C)				85 (29°C)				95 (35°C)				105 (40°C)				115 (46°C)				125 (51°C)			
		Capacity MBtuh		Total System KW	Capacity MBtuh		Total System KW	Capacity MBtuh		Total System KW	Capacity MBtuh		Total System KW	Capacity MBtuh		Total System KW	Capacity MBtuh		Total System KW	Capacity MBtuh		Total System KW			
		Total	Sens		Total	Sens		Total	Sens		Total	Sens		Total	Sens		Total	Sens		Total	Sens		Total	Sens	
525	57	16.75	16.75	1.25	15.69	15.69	1.38	14.68	14.68	1.54	13.72	13.72	1.72	12.82	12.82	1.93	11.99	11.99	2.18						
	62	17.45	15.53	1.24	16.17	14.80	1.38	14.96	14.11	1.54	13.84	13.44	1.72	12.82	12.82	1.93	11.99	11.99	2.18						
	63*	17.88	12.78	1.24	16.58	12.12	1.38	15.34	11.49	1.54	14.18	10.90	1.72	13.10	10.34	1.93	12.10	9.81	2.18						
	67	19.48	13.29	1.24	18.09	12.63	1.38	16.77	11.99	1.54	15.53	11.39	1.73	14.38	10.82	1.94	13.31	10.29	2.20						
600	57	21.75	11.03	1.23	20.25	10.42	1.37	18.82	9.85	1.53	17.47	9.30	1.73	16.20	8.79	1.95	15.02	8.31	2.21						
	62	17.66	17.66	1.27	16.53	16.53	1.41	15.45	15.45	1.57	14.44	14.44	1.75	13.48	13.48	1.97	12.59	12.59	2.22						
	63*	18.38	13.69	1.27	17.02	13.00	1.41	15.73	12.34	1.57	14.53	11.72	1.75	13.41	11.13	1.97	12.37	10.58	2.22						
	67	20.02	14.26	1.26	18.57	13.57	1.40	17.20	12.90	1.56	15.91	12.27	1.75	14.71	11.67	1.97	13.60	11.11	2.23						
675	57	22.34	11.65	1.25	20.78	11.03	1.39	19.29	10.43	1.56	17.89	9.87	1.75	16.57	9.34	1.98	15.35	8.84	2.24						
	62	18.43	18.43	1.29	17.25	17.25	1.43	16.12	16.12	1.59	15.05	15.05	1.78	14.04	14.04	2.00	13.10	13.10	2.26						
	63*	18.44	18.43	1.29	17.25	17.25	1.43	16.12	16.12	1.59	15.05	15.05	1.78	14.04	14.04	2.00	13.10	13.10	2.26						
	67	20.43	15.19	1.28	18.94	14.47	1.42	17.53	13.78	1.59	16.20	13.12	1.78	14.96	12.50	2.00	13.82	11.91	2.25						
	72	22.78	12.25	1.27	21.17	11.61	1.41	19.64	10.99	1.58	18.20	10.41	1.78	16.84	9.86	2.00	15.58	9.35	2.27						

PY3P 024 Cooling Performance Table

EVAPORATOR AIR		CONDENSER ENTERING AIR TEMPERATURES °F																							
CFM	EWB	75 (23°C)				85 (29°C)				95 (35°C)				105 (40°C)				115 (46°C)				125 (51°C)			
		Capacity MBtuh		Total System KW	Capacity MBtuh		Total System KW	Capacity MBtuh		Total System KW	Capacity MBtuh		Total System KW	Capacity MBtuh		Total System KW	Capacity MBtuh		Total System KW	Capacity MBtuh		Total System KW			
		Total	Sens		Total	Sens		Total	Sens		Total	Sens		Total	Sens		Total	Sens		Total	Sens		Total	Sens	
700	57	21.94	21.94	1.65	21.57	21.57	1.82	21.06	21.06	2.01	20.45	20.45	2.23	19.66	19.66	2.46	18.68	18.68	2.70						
	62	22.28	20.87	1.65	21.84	20.85	1.82	21.25	20.68	2.01	20.53	20.39	2.23	19.66	19.66	2.46	18.68	18.68	2.70						
	63*	22.30	16.74	1.65	21.92	16.78	1.82	21.37	16.68	2.02	20.64	16.46	2.23	19.69	16.12	2.46	18.45	15.61	2.70						
	67	23.20	16.51	1.65	23.01	16.77	1.82	22.49	16.74	2.02	21.84	16.64	2.23	21.03	16.48	2.46	19.94	16.16	2.70						
800	57	23.83	12.47	1.65	23.96	12.72	1.82	23.51	12.64	2.02	22.94	12.52	2.23	22.23	12.37	2.47	21.33	12.18	2.72						
	62	22.32	22.32	1.69	22.02	22.02	1.86	21.55	21.55	2.05	20.99	20.99	2.26	20.27	20.27	2.50	19.34	19.34	2.74						
	63*	22.45	21.80	1.69	22.10	21.89	1.86	21.55	21.55	2.05	20.99	20.99	2.26	20.27	20.27	2.50	19.34	19.34	2.74						
	67	23.22	17.00	1.69	23.11	17.44	1.86	22.60	17.50	2.05	21.95	17.48	2.27	21.18	17.41	2.50	20.14	17.20	2.74						
900	57	23.80	12.61	1.69	23.96	12.93	1.86	23.54	12.90	2.06	22.97	12.83	2.27	22.26	12.72	2.51	21.38	12.58	2.76						
	62	22.50	22.50	1.73	22.29	22.29	1.90	21.85	21.85	2.09	21.31	21.31	2.30	20.65	20.65	2.54	19.76	19.76	2.78						
	63*	22.49	22.49	1.73	22.29	22.29	1.90	21.84	21.84	2.09	21.31	21.31	2.30	20.64	20.64	2.54	19.76	19.76	2.78						
	67	23.19	17.40	1.73	23.13	18.24	1.90	21.62	18.32	2.09	20.95	18.27	2.31	20.09	18.10	2.54	18.94	17.72	2.78						
	72	23.74	12.72	1.73	23.92	13.09	1.90	23.52	13.12	2.10	22.96	13.08	2.31	22.25	13.01	2.55	21.37	12.92	2.80						

PY3P 030 Cooling Performance Table

EVAPORATOR AIR		CONDENSER ENTERING AIR TEMPERATURES °F																							
CFM	EWB	75 (23°C)				85 (29°C)				95 (35°C)				105 (40°C)				115 (46°C)				125 (51°C)			
		Capacity MBtuh		Total System KW	Capacity MBtuh		Total System KW	Capacity MBtuh		Total System KW	Capacity MBtuh		Total System KW	Capacity MBtuh		Total System KW	Capacity MBtuh		Total System KW	Capacity MBtuh		Total System KW			
		Total	Sens		Total	Sens		Total	Sens		Total	Sens		Total	Sens		Total	Sens		Total	Sens		Total	Sens	
875	57	26.95	26.95	2.02	26.34	26.34	2.23	25.48	25.48	2.47	24.51	24.51	2.73	23.42	23.42	3.02	22.20	22.20	3.32						
	62	27.37	26.75	2.03	26.69	26.63	2.24	25.67	26.14	2.47	24.52	24.48	2.73	23.42	23.42	3.02	22.19	22.19	3.32						
	63*	27.46	21.57	2.03	26.89	21.57	2.24	25.86	21.17	2.47	24.65	20.67	2.73	23.27	20.07	3.02	21.68	19.34	3.31						
	67	28.71	21.42	2.04	28.56	21.88	2.25	27.72	21.73	2.49	26.58	21.33	2.75	25.29	20.86	3.03	23.79	20.28	3.33						
1000	57	29.54	16.12	2.05	29.87	16.59	2.27	29.54	16.72	2.51	28.50	16.39	2.77	27.33	16.03	3.05	26.06	15.65	3.35						
	62	27.55	27.55	2.08	27.17	27.17	2.29	26.36	26.36	2.53	25.39	25.39	2.79	24.31	24.31	3.07	23.09	23.09	3.38						
	63*	27.62	22.52	2.08	27.20	22.81	2.29	26.22	22.50	2.53	25.03	22.05	2.79	23.66	21.49	3.07	22.09	20.77	3.37						
	67	28.75	22.16	2.09	28.71	22.93	2.31	28.00	23.00	2.55	26.87	22.65	2.80	25.61	22.24	3.08	24.13	21.72	3.38						
1125	57	29.50	16.34	2.10	29.88	16.95	2.32	29.62	17.21	2.56	28.61	16.96	2.82	27.44	16.64	3.10	26.18	16.32	3.40						
	62	27.86	27.86	2.14	27.69	27.69	2.35	26.98	26.98	2.59	26.03	26.03	2.85	24.96	24.96	3.13	23.74	23.74	3.43						
	63*	27.66	23.33	2.13	27.69	23.69	2.35	26.98	23.70	2.58	25.02	23.31	2.84	23.95	22.77	3.12	22.42	22.09	3.43						
	67	28.73	22.77	2.14	28.78	23.84	2.36	28.16	24.13	2.60	27.03	23.83	2.86	25.79	23.47	3.14	24.37	23.01	3.44						
	72	29.42	16.51	2.15	29.85	17.24	2.37	29.63	17.63	2.61	28.65	17.45	2.87	27.47	17.15	3.15	26.21	16.90	3.46						

PY3P 036 Cooling Performance Table

EVAPORATOR AIR		CONDENSER ENTERING AIR TEMPERATURES °F																							
CFM	EWB	75 (23°C)				85 (29°C)				95 (35°C)				105 (40°C)				115 (46°C)				125 (51°C)			
		Capacity MBtuh		Total System KW	Capacity MBtuh		Total System KW	Capacity MBtuh		Total System KW	Capacity MBtuh		Total System KW	Capacity MBtuh		Total System KW	Capacity MBtuh		Total System KW	Capacity MBtuh		Total System KW			
		Total	Sens		Total	Sens		Total	Sens		Total	Sens		Total	Sens		Total	Sens		Total	Sens		Total	Sens	
1050	57	33.39	33.39	2.54	32.14	32.14	2.78	30.82	30.82	3.04	29.49	29.49	3.34	28.03	28.03	3.66	26.43	26.43	4.00						
	62	34.27	32.52	2.56	32.73	31.76	2.79	31.10	30.93	3.05	29.53	29.41	3.34	28.03	28.03	3.66	26.43	26.43	4.00						
	63*	34.86	26.55	2.56	33.27	25.82	2.79	31.53	25.03	3.05	29.82	24.26	3.34	27.92	23.42	3.65	25.85	22.51	3.99						
	67	37.57	27.50	2.61	36.09	26.84	2.84	34.32	26.08	3.10	32.51	25.33	3.39	30.58	24.53	3.71	28.48	23.67	4.05						
1200	57	40.91	22.21	2.64	39.71	21.75	2.89	38.19	21.16	3.18	36.27	20.40	3.48	34.27	19.64	3.80	32.08	18.84	4.15						

PERFORMANCE DATA CONTINUED

PY3P 042 Cooling Performance Table

EVAPORATOR AIR		CONDENSER ENTERING AIR TEMPERATURES °F																	
CFM	EWB	75 (23°C)			85 (29°C)			95 (35°C)			105 (40°C)			115 (46°C)			125 (51°C)		
		Capacity MBtuh		Total System KW	Capacity MBtuh		Total System KW	Capacity MBtuh		Total System KW	Capacity MBtuh		Total System KW	Capacity MBtuh		Total System KW	Capacity MBtuh		Total System KW
		Total	Sens		Total	Sens		Total	Sens		Total	Sens		Total	Sens		Total	Sens	
1225	57	38.27	38.27	2.86	36.85	36.85	3.16	35.23	35.23	3.49	33.55	33.55	3.85	31.85	31.85	4.25	30.03	30.03	4.67
	62	39.30	36.30	2.87	37.53	35.43	3.17	35.57	34.41	3.50	33.55	33.55	3.85	31.84	31.84	4.25	30.03	30.03	4.67
	63*	39.98	29.68	2.88	38.12	28.85	3.18	36.05	27.94	3.50	33.84	26.97	3.85	31.65	26.02	4.24	29.31	25.01	4.65
	67	43.26	30.79	2.91	41.32	29.98	3.22	39.26	29.14	3.56	36.95	28.19	3.91	34.63	27.26	4.30	32.24	26.30	4.72
1400	57	47.84	25.12	2.98	45.85	24.37	3.28	43.72	23.58	3.62	41.44	22.74	3.99	38.90	21.82	4.38	36.39	20.92	4.82
	62	39.96	39.96	2.95	38.45	38.45	3.26	36.79	36.79	3.59	34.98	34.98	3.95	33.18	33.18	4.34	31.29	31.29	4.77
	67	44.12	32.87	2.99	42.12	32.06	3.30	40.00	31.20	3.64	37.63	30.25	3.99	35.24	29.28	4.38	32.84	28.31	4.81
	72	48.74	26.43	3.06	46.70	25.68	3.36	44.50	24.88	3.70	42.17	24.05	4.07	39.55	23.11	4.46	36.93	22.20	4.90
1575	57	41.38	41.38	3.03	39.78	39.78	3.34	38.09	38.09	3.68	36.19	36.19	4.04	34.29	34.29	4.44	32.35	32.35	4.87
	62	41.38	41.38	3.03	39.77	39.77	3.34	38.09	38.09	3.68	36.19	36.19	4.04	34.29	34.29	4.44	32.34	32.34	4.87
	63*	41.45	33.52	3.03	39.45	32.64	3.34	37.35	31.73	3.67	34.98	30.68	4.01	32.68	29.66	4.40	30.30	28.55	4.82
	67	44.76	34.86	3.07	42.73	34.04	3.38	40.57	33.17	3.71	38.21	32.22	4.07	35.73	31.20	4.46	33.30	30.19	4.89
72	49.42	27.70	3.14	47.32	26.92	3.44	45.10	26.13	3.78	42.71	25.29	4.15	40.02	24.36	4.54	37.32	23.43	4.98	

PY3P 048 Cooling Performance Table

EVAPORATOR AIR		CONDENSER ENTERING AIR TEMPERATURES °F																	
CFM	EWB	75 (23°C)			85 (29°C)			95 (35°C)			105 (40°C)			115 (46°C)			125 (51°C)		
		Capacity MBtuh		Total System KW	Capacity MBtuh		Total System KW	Capacity MBtuh		Total System KW	Capacity MBtuh		Total System KW	Capacity MBtuh		Total System KW	Capacity MBtuh		Total System KW
		Total	Sens		Total	Sens		Total	Sens		Total	Sens		Total	Sens		Total	Sens	
1400	57	45.59	45.59	3.42	43.75	43.75	3.74	41.78	41.78	4.08	39.72	39.72	4.45	37.38	37.38	4.82	35.01	35.01	5.23
	62	46.49	44.34	3.44	44.24	43.18	3.75	41.91	41.56	4.09	39.71	39.71	4.45	37.37	37.37	4.82	35.01	35.01	5.23
	63*	47.24	36.13	3.45	44.86	35.06	3.76	42.35	33.94	4.09	39.66	32.75	4.45	36.64	31.43	4.80	33.64	30.11	5.18
	67	51.15	37.51	3.51	48.75	36.51	3.83	46.16	35.43	4.17	43.37	34.29	4.53	40.42	33.09	4.92	37.09	31.74	5.30
1600	57	56.76	30.52	3.59	54.28	29.58	3.92	51.57	28.57	4.27	48.66	27.49	4.65	45.53	26.36	5.05	42.22	25.16	5.47
	62	47.55	47.55	3.54	45.61	45.61	3.86	43.58	43.58	4.21	41.39	41.39	4.58	39.01	39.01	4.96	36.42	36.42	5.37
	63*	48.15	38.55	3.55	45.70	37.46	3.86	43.13	36.33	4.19	40.37	35.12	4.55	37.30	33.75	4.90	34.24	32.35	5.29
	67	52.12	40.10	3.61	49.67	39.09	3.93	47.00	38.00	4.27	44.14	36.83	4.64	41.11	35.60	5.03	37.76	34.21	5.41
1800	57	57.81	32.16	3.69	55.26	31.21	4.02	52.47	30.20	4.37	49.46	29.11	4.75	46.23	27.96	5.16	42.81	26.75	5.58
	62	49.18	49.18	3.65	47.20	47.20	3.97	45.07	45.07	4.32	42.78	42.78	4.69	40.35	40.35	5.09	37.63	37.63	5.50
	63*	49.17	49.17	3.65	47.19	47.19	3.97	45.06	45.06	4.32	42.78	42.78	4.69	40.35	40.35	5.09	37.63	37.63	5.50
	67	52.89	42.59	3.70	50.36	41.56	4.02	47.64	40.44	4.37	44.73	39.25	4.74	41.66	37.96	5.13	38.31	36.50	5.52
72	58.58	33.71	3.79	55.98	32.77	4.11	53.11	31.75	4.47	50.03	30.65	4.85	46.72	29.49	5.26	43.23	28.28	5.68	

PY3P 060 Cooling Performance Table

EVAPORATOR AIR		CONDENSER ENTERING AIR TEMPERATURES °F																	
CFM	EWB	75 (23°C)			85 (29°C)			95 (35°C)			105 (40°C)			115 (46°C)			125 (51°C)		
		Capacity MBtuh		Total System KW	Capacity MBtuh		Total System KW	Capacity MBtuh		Total System KW	Capacity MBtuh		Total System KW	Capacity MBtuh		Total System KW	Capacity MBtuh		Total System KW
		Total	Sens		Total	Sens		Total	Sens		Total	Sens		Total	Sens		Total	Sens	
1750	57	57.71	57.71	4.33	55.12	55.12	4.71	52.40	52.40	5.11	49.50	49.50	5.53	46.44	46.44	5.98	43.21	43.21	6.44
	62	58.61	52.35	4.35	55.47	50.84	4.72	52.40	52.40	5.11	49.50	49.50	5.53	46.44	46.44	5.98	43.21	43.21	6.44
	63*	59.50	42.52	4.36	56.13	41.12	4.73	52.62	39.68	5.11	48.88	38.17	5.51	44.97	36.59	5.92	40.77	34.89	6.33
	67	64.63	44.23	4.45	61.18	42.90	4.83	57.50	41.50	5.23	53.62	40.04	5.64	49.55	38.51	6.07	45.30	36.93	6.52
2000	57	71.92	36.00	4.56	68.31	34.74	4.96	64.43	33.40	5.38	60.31	32.00	5.82	55.95	30.54	6.27	51.39	29.03	6.73
	62	60.30	60.30	4.48	57.58	57.58	4.86	54.70	54.70	5.27	51.65	51.65	5.70	48.42	48.42	6.15	45.02	45.02	6.62
	63*	60.34	60.20	4.48	57.58	57.58	4.86	54.70	54.70	5.27	51.64	51.64	5.70	48.42	48.42	6.15	45.01	45.01	6.62
	67	60.71	45.49	4.48	57.24	44.08	4.85	53.63	42.61	5.24	49.80	41.06	5.64	45.80	39.42	6.06	41.69	37.65	6.49
2250	57	65.94	47.42	4.57	62.38	46.07	4.95	58.59	44.64	5.36	54.80	43.14	5.77	50.43	41.58	6.21	46.10	39.92	6.65
	62	73.32	38.01	4.68	69.58	36.74	5.09	65.56	35.39	5.51	61.30	33.97	5.94	56.79	32.49	6.40	52.09	30.97	6.86
	63*	62.46	62.46	4.61	59.64	59.64	5.00	56.62	56.62	5.41	53.43	53.43	5.85	50.05	50.05	6.30	46.50	46.50	6.78
	67	66.95	50.50	4.69	63.30	49.12	5.07	59.43	47.67	5.48	55.37	46.13	5.90	51.15	44.49	6.34	46.83	42.67	6.79
72	74.35	39.95	4.80	70.52	38.67	5.21	66.39	37.31	5.63	62.02	35.88	6.07	57.40	34.39	6.52	52.59	32.85	6.99	

* At 75°F (24°C) entering dry bulb – Tennessee Valley Authority [TVA] rating conditions; all others at 80°F (27°C) entering dry bulb.

LEGEND

- BF — Bypass Factor
- Ewb — Entering Wet-Bulb
- kW — Total Unit Power Input
- SHC — Sensible Heat Capacity (1000 Btuh)
- TC — Total Capacity (1000 Btuh) (net)

NOTES:

1. Ratings are net; they account for the effects of the evaporator-fan motor power and heat.
2. Direct interpolation is permissible. Do not extrapolate.
3. The following formulas may be used:

Sensible capacity (Btuh)

$$1.10 \times \text{cfm}$$

$$t_{db} = t_{edb} -$$

$$t_{wb} = \frac{\text{Wet-bulb temperature corresponding to enthalpy}}{\text{air leaving evaporator coil } (h_{lwb})}$$

$$h_{lwb} = \frac{\text{total capacity (Btuh)}}{4.5 \times \text{cfm}}$$

Where: h_{ewb} = Enthalpy of air entering evaporator coil

4. The SHC is based on 80°F (27°C) edb temperature of air entering evaporator coil. Below 80°F (27°C) edb, subtract (corr factor x cfm) from SHC. Above 80°F (27°C) edb, add (corr factor x cfm) to SHC. Correction Factor = $1.10 \times (1 + BF) \times (edb + 80)$.

PERFORMANCE DATA CONTINUED

Dry Coil Air Delivery* - Horizontal and Downflow Discharge - Unit PY3P018-060 (Deduct 10% for 208 Volts)

UNIT	HEATING RISE RANGE OF	MOTOR SPEED	EXTERNAL STATIC PRESSURE (IN. W.C.)											
			0.1	0.2	0.3	0.4	0.5	0.6	0.7	0.8	0.9			
PY3P018040	30 – 60	Low ¹	WATTS	260	243	229	217	209	--	--	--	--		
			CFM	859	775	667	536	382	--	--	--	--		
			HEATING RISE OF	35	39	45	56	NA	NA	NA	NA	NA		
		High	WATTS	340	328	317	307	300	294	--	--	--		
			CFM	1064	948	820	680	528	364	--	--	--		
			HEATING RISE OF	NA	32	37	44	57	NA	NA	NA	NA		
PY3P024040	20 – 50	Low ¹	WATTS	311	309	304	301	286	290	286	280	-----		
			CFM	935	885	820	757	686	583	423	263	-----		
			HEATING RISE OF	32	34	37	40	44	NA	NA	NA	NA		
		Medium	WATTS	411	405	398	390	379	357	357	345	327		
			CFM	1195	1155	1100	1028	957	868	769	647	365		
			HEATING RISE OF	25	26	27	29	31	35	39	46	NA		
		High	WATTS	528	518	509	492	477	467	447	435	421		
			CFM	1484	1421	1368	1279	1185	1088	970	853	712		
			HEATING RISE OF	20	21	22	23	25	28	31	35	42		
		PY3P024060	35 – 65	Low ¹	WATTS	311	309	304	301	286	290	286	280	-----
					CFM	935	885	820	757	686	583	423	263	-----
					HEATING RISE OF	48	51	55	59	NA	NA	NA	NA	NA
Medium	WATTS			411	405	398	390	379	357	357	345	327		
	CFM			1195	1155	1100	1028	957	868	769	647	365		
	HEATING RISE OF			38	39	41	44	47	52	59	NA	NA		
High	WATTS			528	518	509	492	477	467	447	435	421		
	CFM			1484	1421	1368	1279	1185	1088	970	853	712		
	HEATING RISE OF			NA	NA	NA	35	38	41	46	53	63		
PY3P030040	20 – 50			Low	WATTS	311	309	304	301	286	290	286	280	-----
					CFM	935	885	820	757	686	583	423	263	-----
					HEATING RISE OF	32	34	37	40	44	NA	NA	NA	NA
		Medium ¹	WATTS	411	405	398	390	379	357	357	345	327		
			CFM	1195	1155	1100	1028	957	868	769	647	365		
			HEATING RISE OF	25	26	27	29	31	35	39	46	NA		
		High	WATTS	528	518	509	492	477	467	447	435	421		
			CFM	1484	1421	1368	1279	1185	1088	970	853	712		
			HEATING RISE OF	20	21	22	23	25	28	31	35	42		
		PY3P030060	35 – 65	Low	WATTS	311	309	304	301	286	290	286	280	-----
					CFM	935	885	820	757	686	583	423	263	-----
					HEATING RISE OF	48	51	55	59	NA	NA	NA	NA	NA
Medium ¹	WATTS			411	405	398	390	379	357	357	345	327		
	CFM			1195	1155	1100	1028	957	868	769	647	365		
	HEATING RISE OF			38	39	41	44	47	52	59	NA	NA		
High	WATTS			528	518	509	492	477	467	447	435	421		
	CFM			1484	1421	1368	1279	1185	1088	970	853	712		
	HEATING RISE OF			NA	NA	NA	35	38	41	46	53	63		
PY3P036060	25 – 55			Low	WATTS	439	429	415	401	395	380	356	339	329
					CFM	1242	1170	1089	994	917	837	702	570	442
					HEATING RISE OF	36	38	41	45	49	54	NA	NA	NA
		Medium ¹	WATTS	503	491	479	461	450	436	418	404	389		
			CFM	1320	1244	1162	1081	1005	897	767	662	541		
			HEATING RISE OF	34	36	39	42	45	50	NA	NA	NA		
		High	WATTS	641	627	623	609	601	588	571	559	548		
			CFM	1362	1288	1205	1119	1033	933	826	714	580		
			HEATING RISE OF	33	35	37	40	44	48	54	NA	NA		
		PY3P036090	40 – 70	Low	WATTS	439	429	415	401	395	380	356	339	329
					CFM	1242	1170	1089	994	917	837	702	570	442
					HEATING RISE OF	54	58	62	68	NA	NA	NA	NA	NA
Medium ¹	WATTS			503	491	479	461	450	436	418	404	389		
	CFM			1320	1244	1162	1081	1005	897	767	662	541		
	HEATING RISE OF			51	54	58	62	67	NA	NA	NA	NA		
High	WATTS			641	627	623	609	601	588	571	559	548		
	CFM			1362	1288	1205	1119	1033	933	826	714	580		
	HEATING RISE OF			50	52	56	60	65	NA	NA	NA	NA		
PY3P042060	25 – 55			Low	WATTS	434	428	422	403	404	390	375	360	344
					CFM	1282	1241	1206	1160	1109	1040	967	890	813
					HEATING RISE OF	35	36	37	39	41	43	47	51	55
		Medium ¹	WATTS	560	548	535	526	511	496	478	460	439		
			CFM	1526	1482	1437	1398	1344	1281	1205	1125	1029		
			HEATING RISE OF	29	30	31	32	33	35	37	40	44		
		High	WATTS	765	746	730	709	690	664	642	624	600		
			CFM	1860	1805	1751	1685	1620	1541	1468	1370	1265		
			HEATING RISE OF	NA	25	26	27	28	29	31	33	36		

PY3P

PERFORMANCE DATA CONTINUED

Dry Coil Air Delivery* - Horizontal and Downflow Discharge - Unit PY3P018-060 (Deduct 10% for 208 Volts) (Cont)

UNIT	HEATING RISE RANGE °F	MOTOR SPEED	EXTERNAL STATIC PRESSURE (IN. W.C.)									
			0.1	0.2	0.3	0.4	0.5	0.6	0.7	0.8	0.9	
PY3P042090	40 – 70	Low	Watts	434	428	422	403	404	390	375	360	344
			CFM	1282	1241	1206	1160	1109	1040	967	890	813
			Heating Rise °F	53	54	56	58	61	65	70	NA	NA
		Medium ¹	Watts	560	548	535	526	511	496	478	460	439
			CFM	1526	1482	1437	1398	1344	1281	1205	1125	1029
			Heating Rise °F	44	46	47	48	50	53	56	60	66
		High	Watts	765	746	730	709	690	664	642	624	600
			CFM	1860	1805	1751	1685	1620	1541	1468	1370	1265
			Heating Rise °F	NA	NA	NA	40	42	44	46	49	53
PY3P048090	25 – 55	Low	Watts	627	617	607	584	567	548	528	503	480
			CFM	1550	1530	1493	1461	1414	1361	1320	1250	1177
			Heating Rise °F	44	44	45	46	48	50	51	54	NA
		Medium ¹	Watts	771	755	734	711	690	665	639	607	572
			CFM	1798	1771	1734	1687	1645	1595	1530	1449	1355
			Heating Rise °F	38	38	39	40	41	42	44	47	50
		High	Watts	969	941	908	887	858	827	804	767	748
			CFM	2124	2071	2000	1944	1876	1811	1735	1647	1555
			Heating Rise °F	32	33	34	35	36	37	39	41	43
PY3P048115	35 – 65	Low	Watts	627	617	607	584	567	548	528	503	480
			CFM	1550	1530	1493	1461	1414	1361	1320	1250	1177
			Heating Rise °F	56	56	58	59	61	63	65	NA	NA
		Medium ¹	Watts	771	755	734	711	690	665	639	607	572
			CFM	1798	1771	1734	1687	1645	1595	1530	1449	1355
			Heating Rise °F	48	49	50	51	52	54	56	60	64
		High	Watts	969	941	908	887	858	827	804	767	748
			CFM	2124	2071	2000	1944	1876	1811	1735	1647	1555
			Heating Rise °F	41	42	43	44	46	48	50	52	55
PY3P048130	40 – 70	Low	Watts	627	617	607	584	567	548	528	503	480
			CFM	1550	1530	1493	1461	1414	1361	1320	1250	1177
			Heating Rise °F	63	64	65	67	69	NA	NA	NA	NA
		Medium ¹	Watts	771	755	734	711	690	665	639	607	572
			CFM	1798	1771	1734	1687	1645	1595	1530	1449	1355
			Heating Rise °F	54	55	56	58	59	61	64	67	NA
		High	Watts	969	941	908	887	858	827	804	767	748
			CFM	2124	2071	2000	1944	1876	1811	1735	1647	1555
			Heating Rise °F	46	47	49	50	52	54	56	59	63
PY3P060090	25 – 55	Low ¹	Watts	786	769	754	736	722	705	684	658	616
			CFM	2027	1960	1901	1821	1759	1693	1616	1513	1354
			Heating Rise °F	33	34	36	37	38	40	42	45	50
		Medium	Watts	873	849	833	815	798	782	763	748	704
			CFM	2095	2026	1962	1887	1817	1748	1679	1583	1439
			Heating Rise °F	32	33	34	36	37	39	40	43	47
		High	Watts	1012	993	981	963	948	927	904	886	846
			CFM	2184	2109	2036	1963	1886	1812	1729	1647	1496
			Heating Rise °F	31	32	33	34	36	37	39	41	45
PY3P060115	35 – 65	Low ¹	Watts	786	769	754	736	722	705	684	658	616
			CFM	2027	1960	1901	1821	1759	1693	1616	1513	1354
			Heating Rise °F	43	44	45	47	49	51	53	57	64
		Medium	Watts	873	849	833	815	798	782	763	748	704
			CFM	2095	2026	1962	1887	1817	1748	1679	1583	1439
			Heating Rise °F	41	43	44	46	47	49	51	54	60
		High	Watts	1012	993	981	963	948	927	904	886	846
			CFM	2184	2109	2036	1963	1886	1812	1729	1647	1496
			Heating Rise °F	39	41	42	44	46	48	50	52	58
PY3P060130	40 – 70	Low ¹	Watts	786	769	754	736	722	705	684	658	616
			CFM	2027	1960	1901	1821	1759	1693	1616	1513	1354
			Heating Rise °F	48	50	51	54	55	58	60	64	NA
		Medium	Watts	873	849	833	815	798	782	763	748	704
			CFM	2095	2026	1962	1887	1817	1748	1679	1583	1439
			Heating Rise °F	47	48	50	52	54	56	58	62	68
		High	Watts	1012	993	981	963	948	927	904	886	846
			CFM	2184	2109	2036	1963	1886	1812	1729	1647	1496
			Heating Rise °F	45	46	48	50	52	54	56	59	65

*Air delivery values are without air filter and are for dry coil (see Wet Coil Pressure Drop table).

¹Factory – shipped heating/cooling speed

"NA" = Not allowed for heating speed

Note: Deduct field – supplied air filter pressure drop and wet coil pressure drop to obtain external static pressure available for ducting.

PERFORMANCE DATA (CONT)

FILTER PRESSURE DROP (IN. W.C.)

FILTER SIZE	CFM																		
	500	600	700	800	900	1000	1100	1200	1300	1400	1500	1600	1700	1800	1900	2000	2100	2200	2300
20X20X1 508X508X25 mm	0.05	0.07	0.08	0.1	0.12	0.13	0.14	0.15	—	—	—	—	—	—	—	—	—	—	—
20X24X1 508X610x25 mm	—	—	—	—	0.09	0.10	0.11	0.13	0.14	0.15	0.16	—	—	—	—	—	—	—	—
24X30X1 610X762x25 mm	—	—	—	0.04	0.05	0.06	0.07	0.07	0.08	0.09	0.1	—	—	—	—	—	—	—	—
24X36X1 610X914X25 mm	—	—	—	—	—	—	—	0.06	0.07	0.07	0.08	0.09	0.09	0.10	0.11	0.12	0.13	0.14	0.14

PY3P Wet Coil Pressure Drop (IN. W.C.)

UNIT SIZE	STANDARD CFM (S.C.F.M.)																
	500	600	700	800	900	1000	1100	1200	1300	1400	1500	1600	1700	1800	1900	2000	
018	0.011	0.013	0.018	0.022	—	—	—	—	—	—	—	—	—	—	—	—	
024	—	0.030	0.037	0.044	0.053	0.063	—	—	—	—	—	—	—	—	—	—	
030	—	—	0.037	0.044	0.053	0.063	0.072	0.081	0.105	—	—	—	—	—	—	—	
036	—	—	—	—	0.05	0.061	0.072	0.080	0.090	0.110	—	—	—	—	—	—	
042	—	—	—	—	—	0.044	0.051	0.059	0.065	0.072	0.080	0.088	0.095	0.105	—	—	
048	—	—	—	—	—	—	—	0.044	0.050	0.053	0.059	0.066	0.072	0.077	0.086	—	
060	—	—	—	—	—	—	—	—	—	—	—	0.079	0.087	0.095	0.102	0.113	0.123

Economizer 1-in. Filter Pressure Drop (IN. W.C.)

UNIT PY3P	PRESSURE DROP
018–036	0.20
042–060	0.25

HIGH ALTITUDE COMPENSATION

Natural Gas Only

Orifice Conversion—3.5 IN. W.C. Manifold Pressure*

ALTITUDE ft (m)	INPUT (Btuh)	ORIFICE NUMBER†
0–2000 (0–610 m)	40,000	#44
	60,000	#38
	90,000	#38
	115,000	#33
	130,000	#31
2001–4500 (610–1372 m)	32,800	#48
	49,200	#42
	73,800	#42
	94,300	#36
	106,600	#33

*As the height above sea level increases, there is less oxygen per cubic ft of air. Therefore, heat input rate should be reduced at higher altitudes.

†Orifices available through your distributor.

Propane Gas Only

Orifice Conversion—3.5 IN. W.C. Manifold Pressure*

ALTITUDE ft (m)	INPUT (Btuh)	ORIFICE NUMBER†
0–2000 (0–610 m)	40,000	#50
	57,000	#46
	85,500	#46
	115,000	#42
	127,000	#41
	31,200	#52
2001–6000 (610–1829 m)	46,800	#48
	70,200	#48
	89,700	#44
	101,400	#43

*As the height above sea level increases, there is less oxygen per cubic ft of air. Therefore, heat input rate should be reduced at higher altitudes.

†Orifices available through your distributor.

PY3P

TYPICAL PIPING AND WIRING

PY3P

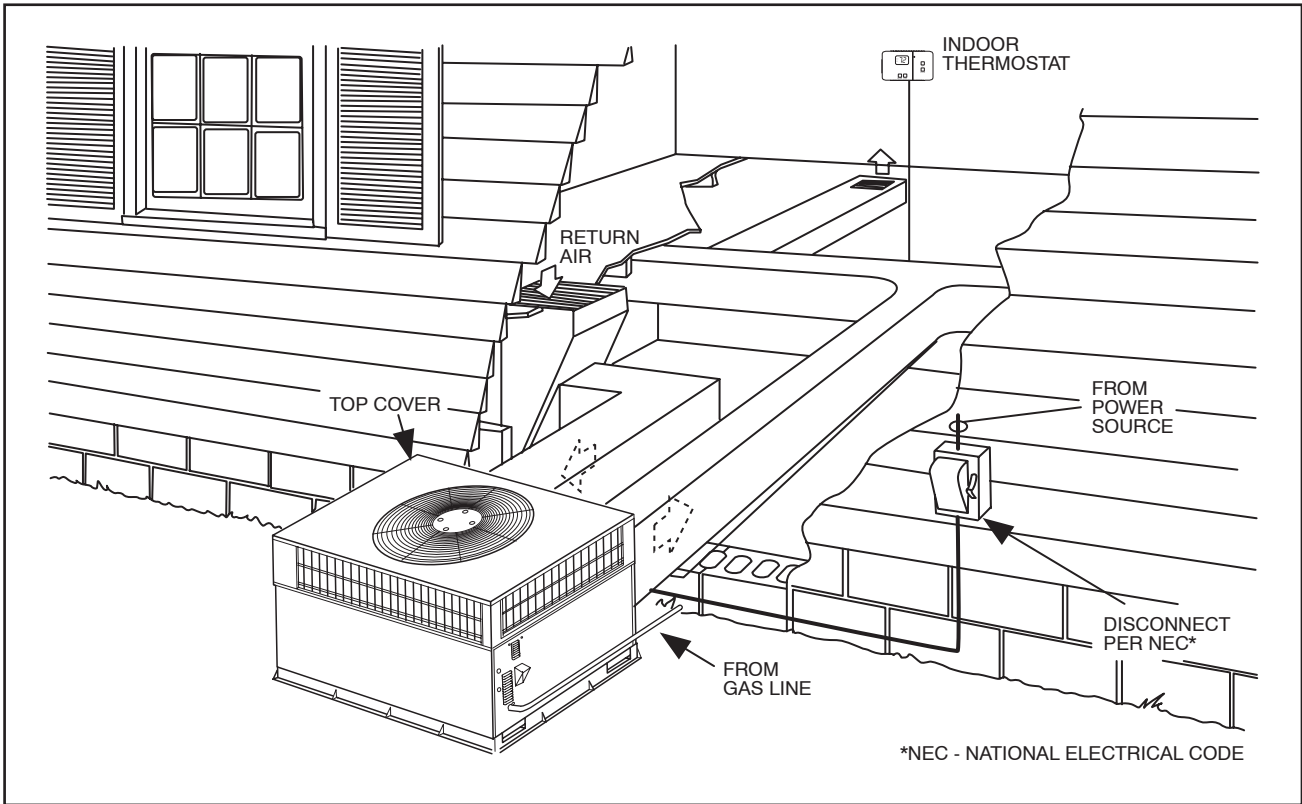
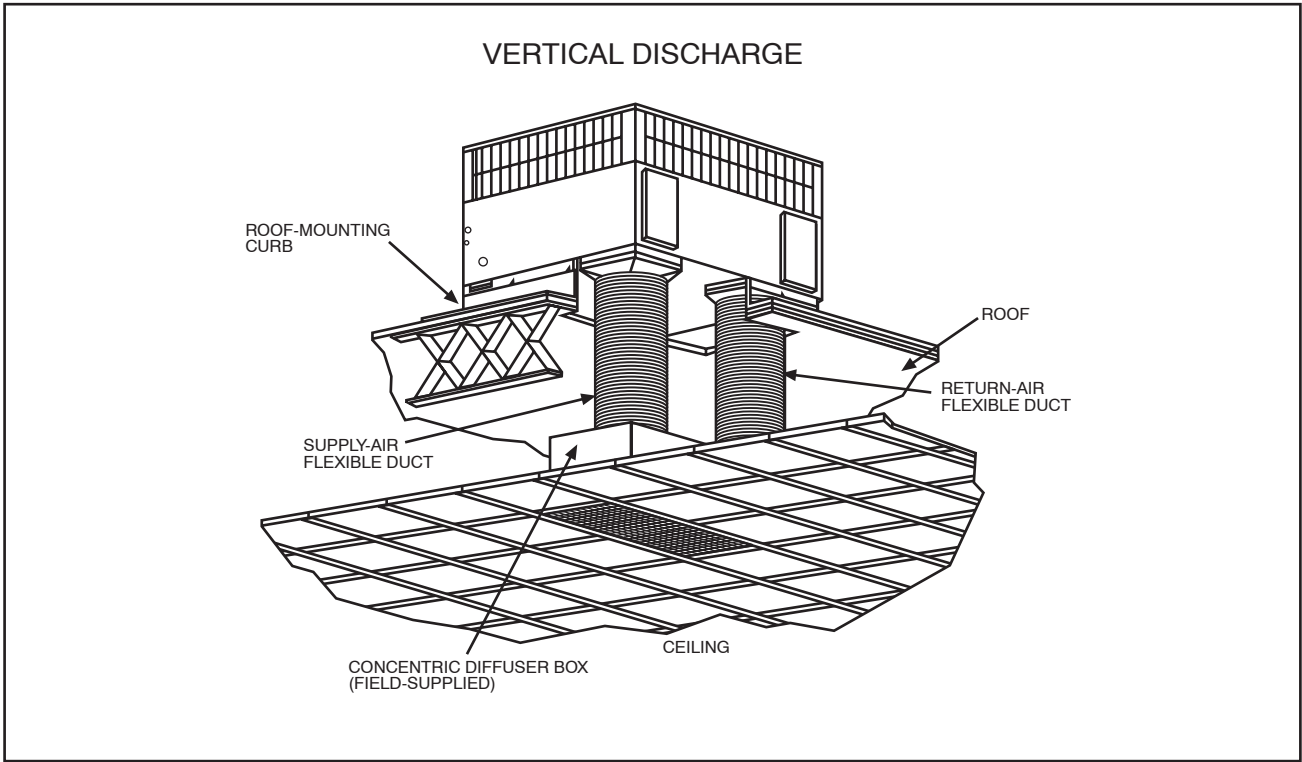

APPLICATION DATA

Condensate trap — A 2-in. (50.8 mm) condensate trap must be field supplied.

Ductwork — Secure downflow discharge ductwork to roof curb. For horizontal discharge applications, attach ductwork to unit with flanges.

To convert a unit to downflow discharge — Units are equipped with factory-installed inserts in the down-flow openings. Removal of the inserts is similar to removing an electrical knock-out. Use the duct cover to seal the horizontal discharge openings in the unit. Units installed in horizontal discharge orientation do not require duct covers.

Airflow — Units are draw-thru in the cooling mode and blow-thru in the heating mode.

Maximum cooling airflow — To minimize the possibility of condensate blow-off from the evaporator, airflow through the units should not exceed 450 cfm per ton.

Minimum cooling airflow — Minimum cooling airflow is 350 cfm per ton.

Minimum ambient cooling operation temperature — All standard units have a minimum ambient operating temperature of 40°F (4°C). With accessory low ambient temperature kit, units can operate at temperatures down to 0°F (-17°C).

Minimum temperature — Air entering the heat exchanger in heating mode must be a minimum of 50°F (10°C) continuous and/or 45°F (7°C) intermittent.

ELECTRICAL DATA

UNIT	NOMINAL V-PH-HZ	VOLTAGE RANGE		COMPRESSOR #1		OUTDOOR FAN MOTOR	INDOOR FAN MOTOR	POWER SUPPLY	
		MIN	MAX	RLA	LRA	FLA	FLA	MCA	MOCP
PY3P-018	208/230-1-60	187	253	7.7	40.3	0.9	1.8	12.3	20
PY3P-024	208/230-1-60	187	253	10.4	54.0	0.9	2.0	15.9	25
PY3P-030	208/230-1-60	187	253	14.1	68.0	0.9	2.0	20.5	30
	208/230-3-60	187	253	9.9	58.0	0.9	2.0	15.3	25
PY3P-036	208/230-1-60	187	253	14.4	77.0	0.9	4.1	23.0	35
	208/230-3-60	187	253	10.0	73.0	0.9	4.1	17.5	25
	460-3-60	414	506	5.8	38.0	0.6	1.9	9.8	15
PY3P-042	208/230-1-60	187	253	19.2	104.0	0.9	3.1	28.0	40
	208/230-3-60	187	253	12.8	88.0	0.9	3.1	20.0	30
	460-3-60	414	506	5.8	44.0	0.6	1.6	9.5	15
PY3P-048	208/230-1-60	187	253	19.2	97.0	1.5	4.1	29.6	40
	208/230-3-60	187	253	12.5	88.0	1.5	4.1	21.2	30
	460-3-60	414	506	6.6	44.0	0.9	1.9	11.1	15
PY3P-060	208/230-1-60	187	253	25.3	141.0	1.5	6.2	39.3	60
	208/230-3-60	187	253	15.8	110.0	1.5	6.2	27.5	40
	460-3-60	414	506	7.6	52.0	0.9	2.7	13.1	20

LEGEND

- FLA — Full Load Amps
- LRA — Locked Rotor Amps
- MCA -- Minimum Circuit Amps
- MOCP — Maximum Overcurrent Protection
- RLA — Rated Load Amps



EXAMPLE: Supply voltage is 230-3-60.

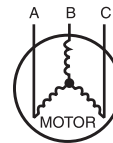

- AB = 228 v
- BC = 231 v
- AC = 227 v

$$\begin{aligned} \text{Average Voltage} &= \frac{228 + 231 + 227}{3} \\ &= \frac{686}{3} \\ &= 229 \end{aligned}$$

NOTES:

- In compliance with NEC (National Electrical Code) requirements for multimotor and combination load equipment (refer to NEC Articles 430 and 440), the overcurrent protective device for the unit shall be Power Supply fuse. The CGA (Canadian Gas Association) units may be fuse or circuit breaker.
- Minimum wire size is based on 60 C copper wire. If other than 60 C wire is used, or if length exceeds wire length in table, determine size from NEC.
- Unbalanced 3-Phase Supply Voltage
Never operate a motor where a phase imbalance in supply voltage is greater than 2%. Use the following formula to determine the percentage of voltage imbalance

% Voltage imbalance

$$= 100 \times \frac{\text{max voltage deviation from average voltage}}{\text{average voltage}}$$

- * Heater capacity (kW) based on heater voltage of 208v & 240v. If power distribution voltage to unit varies from rated heater voltage, heater kW will vary accordingly.

Determine maximum deviation from average voltage.

- (AB) 229 - 228 = 1 v
- (BC) 231 - 229 = 2 v
- (AC) 229 - 227 = 2 v

Maximum deviation is 2 v.

Determine percent of voltage imbalance

$$\begin{aligned} \% \text{ Voltage Imbalance} &= 100 \times \frac{2}{229} \\ &= 0.8\% \end{aligned}$$

This amount of phase imbalance is satisfactory as it is below the maximum allowable 2%.

IMPORTANT: If the supply voltage phase imbalance is more than 2%, contact your local electric utility company immediately.

CONTROLS

Operating sequence

Heating — When the thermostat calls for heating, terminal “W” is energized, starting the induced draft motor. When the hall-effect sensor on the induced-draft motor senses that it has reached the required speed, the burner ignition sequence begins. The indoor (evaporator) fan motor (IFM) is energized 45 seconds after flame is established. When the thermostat is satisfied and “W” is de-energized, the IFM stops after a 45-second time-off delay. Please note that the ignition control board (IGC) has the capability to automatically reduce the indoor fan motor on and off delays in the event of high duct static and/or partially-clogged filter. An adjustment of fan delays by the ignition control board is indicated by a flash code “1” on the LED on the IGC.

Cooling — When the system thermostat calls for cooling, 24 V is supplied to the “Y” and “G” terminals of the thermostat. This completes the circuit to the contactor coil (C) and indoor (evaporator) fan relay (IFR). The normally open contacts of energized C close and complete the circuit through compressor motor (COMP) to outdoor (condenser) fan motor (OFM). Both motors start instantly. The set of normally open contacts of energized IFR close and complete the circuit through IFM. The IFM starts instantly.

On the loss of the thermostat call for cooling, 24 V is removed from both the “Y” and “G” terminals (provided the fan switch is in the “AUTO” position) de-energizing the compressor contactor and opening the contacts supplying power to compressor/OFM. After a 30-second delay, the IFM shuts off. If the thermostat fan selector switch is in the “ON” position, the IFM will run continuously.

NOTE: On units with a Time Guard® II device: Once the compressor has started and then stopped, it cannot be restarted again until 5 minutes have elapsed.

GUIDE SPECIFICATIONS

Packaged Gas Heating/Electric Cooling Units Constant Volume Application

HVAC Guide Specifications

Size Range: **1-1/2 to 5 Tons, Nominal Cooling
40,000 to 130,000 Btuh,
Nominal Heating Input**

Payne Model Number: PY3P

Part 1 — General

SYSTEM DESCRIPTION

Outdoor rooftop mounted, gas heating/electric cooling unit utilizing a hermetic scroll compressor for cooling duty. Unit shall discharge supply air vertically or horizontally as shown on contract drawings. Condenser fan/coil section shall have a draw-thru design with vertical discharge for minimum sound levels.

QUALITY ASSURANCE

- A. Unit shall be rated in accordance with ARI Standards 210/240-03 and 270-95.**
- B. Unit shall be designed in accordance with UL Standard 1995.**
- C. Unit shall be manufactured in a facility registered to ISO 9001 manufacturing quality standard.**
- D. Unit shall be UL listed and c-UL certified as a total package for safety requirements.**
- E. Roof curb shall be designed to conform to NRCA Standards.**
- F. Insulation and adhesives shall meet NFPA 90A requirements for flame spread and smoke generation.**
- G. Cabinet insulation shall meet ASHRAE Standard 62P.**

DELIVERY, STORAGE AND HANDLING

Unit shall be stored and handled per manufacturer's recommendations.

Part 2 — Products

EQUIPMENT

A. General:

Factory-assembled, single-piece, heating and cooling unit. Contained within the enclosure shall be all factory wiring, piping, controls, refrigerant charge (R-22), and special features required prior to field start-up.

B. Unit Cabinet:

- 1. Unit cabinet shall be constructed of phosphated, zinc-coated, pre-painted steel capable of with-standing 500 hours in salt spray.
- 2. Normal service shall be through a single removable cabinet panel.
- 3. The unit shall be constructed on a rust proof unit base that has an externally trapped, integrated sloped drain.
- 4. Evaporator fan compartment top surface shall be insulated with a minimum 1/2-in. thick, flexible fiberglass insulation, coated on the air side and retained by adhesive and mechanical means. The evaporator wall sections will be insulated with a minimum semi-rigid foil-faced board capable of being wiped clean. Aluminum foil-faced fiberglass insulation shall be used in the entire indoor air cavity section.
- 5. Unit shall have a field-supplied condensate trap.

C. Fans:

- 1. The evaporator fan shall be 3-speed (2-speed on 018), direct-drive, as shown on equipment drawings.

- 2. Fan wheel shall be made from steel, be double-inlet type with forward curved blades with corrosion resistant finish. Fan wheel shall be dynamically balanced.
- 3. Condenser fan shall be direct drive propeller type with aluminum blades riveted to corrosion resistant steel spiders, be dynamically balanced, and discharge air vertically.

D. Compressor:

- 1. Fully hermetic compressors with factory-installed vibration isolation.
- 2. Scroll compressors shall be standard on all units.

E. Coils:

Evaporator and condenser coils shall have aluminum plate fins mechanically bonded to seamless copper tubes with all joints brazed (Copper/copper and vinyl-coated construction available as option). Tube sheet openings shall be belled to prevent tube wear.

F. Heating Section:

- 1. Induced-draft combustion type with energy saving direct spark ignition system and redundant main gas valve.
- 2. Induced-draft motors shall be provided with solid-state hall-effect sensor to ensure adequate airflow for combustion.
- 3. The heat exchangers shall be constructed of aluminized steel for corrosion resistance.
- 4. Burners shall be of the in-shot type constructed of aluminum coated steel.
- 5. All gas piping and electric power shall enter the unit cabinet at a single location.

G. Refrigerant Components:

Refrigerant components shall be of the fixed orifice feed type.

H. Filters:

Filter section shall consist of field-installed, throwaway, 1-in. (25 mm) thick fiberglass filters of commercially available sizes.

I. Controls and Safeties:

- 1. Unit controls shall be complete with a self-contained low voltage control circuit.
- 2. Compressors shall incorporate a solid-state compressor protector that provides reset capability.

J. Operating Characteristics:

- 1. Unit shall be capable of starting and running at 125°F (51°C) ambient outdoor temperature per maximum load criteria of ARI Standard 210.
- 2. Compressor with standard controls shall be capable of operation down to 40°F (4°C) ambient outdoor temperature.
- 3. Units shall be provided with fan time delay to prevent cold air delivery before the heat exchanger warms up.
- 4. Unit shall be provided with 30-second fan time delay after the thermostat is satisfied.

K. Electrical Requirements:

All unit power wiring shall enter the unit cabinet at a single location.

L. Motors:

- 1. Compressor motors shall be of the refrigerant-cooled type with line-break thermal and current overload protection.
- 2. All fan motors shall have permanently lubricated bearings, and inherent, automatic reset, thermal overload protection.
- 3. Condenser fan motor shall be totally enclosed.

GUIDE SPECIFICATIONS (CONT)

M. Special Features:

1. Economizer:
 - a. Economizer controls capable of providing free cooling using outside air.
 - b. Equipped with low leakage dampers not to exceed 3% leakage, at 1.0 IN. W.C. pressure differential.
 - c. Spring return motor shuts off outdoor damper on power failure.
2. Flat Roof Curb:

Curbs shall have seal strip and a wood nailer for flashing and shall be installed per manufacturer's instructions.
3. Manual Outdoor Air Damper:

Package shall consist of damper, birdscreen, and rainhood which can be preset to admit outdoor air for year-round ventilation.
4. Thermostat:

To provide for one-stage heating and cooling in addition manual or automatic changeover and indoor fan control.
5. Natural-to-Propane Conversion Kit:

Shall be complete with all required hardware to convert to propane gas operation at 3.5 IN. W.C. manifold pressure.
6. Propane-to-Natural Conversion Kit:

Shall be complete with all hardware to convert to natural gas at standard altitude (0 to 2000 ft above sea level) (0 to 610 m).
7. Low Ambient Package:

Shall consist of a solid-state control and condenser coil temperature sensor for controlling condenser-fan motor operation, which shall allow unit to operate down to 0°F (-17.8°C) outdoor ambient temperature when properly installed.
8. Filter Rack Kit:

Shall provide filter mounting for downflow applications.
9. Controls Upgrade Kit:

Shall provide high and low pressure safety protection.
10. Square-To-Round Duct Transitions (018-048):

Shall have the ability to convert the supply and return openings from rectangular to round.
11. Compressor Protection:

Solid-state control shall protect compressor by preventing "short cycling."
12. Crankcase Heater:

Shall provide anti-floodback protection for low-load cooling applications.
13. High Altitude Propane Conversion Kit:

Shall consist of natural gas orifices to compensate for gas heat operation at 2001 to 6000 ft (610 to 1829 m) above sea level.
14. Low NOx:

Shall provide NOx reduction to values below 40 nano-grams/joule to meet California emission requirements as shipped from factory.
15. Compressor Hard Start Kit (single phase units only):

Shall provide additional starting torque for single-phase compressors.