

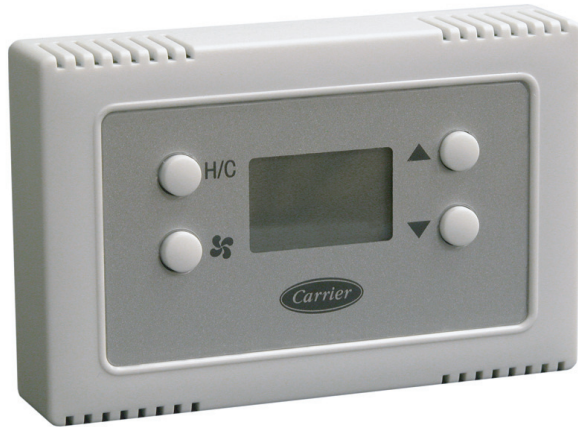

# Installation Instructions



A07108

## Base Non-Programmable Thermostat

**NOTE:** Read the entire instruction manual before starting the installation.

### TABLE OF CONTENTS

	PAGE
SAFETY CONSIDERATIONS .....	1
INTRODUCTION .....	1
INSTALLATION CONSIDERATIONS .....	1
INSTALLATION .....	1
Step 1 — Thermostat Location .....	1
Step 2 — Install Thermostat .....	2
Step 3 — Set Thermostat Configuration .....	2
Step 4 — Thermostat Operation .....	3
Step 5 — Check Thermostat Operation .....	3
WIRING DIAGRAMS .....	4

### SAFETY CONSIDERATIONS

Read and follow manufacturer instructions carefully. Follow all local electrical codes during installation. All wiring must conform to local and national electrical codes. Improper wiring or installation may damage thermostat.

Recognize safety information. This is the safety-alert symbol . When you see this symbol on the equipment and in the instruction manual, be alert to the potential for personal injury. Understand the signal words **DANGER**, **WARNING**, and **CAUTION**.

These words are used with the safety-alert symbol. **DANGER** identifies the most serious hazards which will result in severe personal injury or death. **WARNING** signifies a hazard which

could result in personal injury or death. **CAUTION** is used to identify unsafe practices which may result in minor personal injury or product and property damage. **NOTE** is used to highlight suggestions which will result in enhanced installation, reliability, or operation.

### INTRODUCTION

The Base Series thermostat is an electronic 24VAC, non-programmable, manual changeover wall mount thermostat. This thermostat uses a single setpoint to maintain and control room temperature in both the heating and air conditioning modes. The thermostat is designed to maintain +/- 2°F accuracy. No batteries are required; temperature, fan, mode, and installer configuration settings are preserved with power off.

### INSTALLATION CONSIDERATIONS

#### Air Conditioner Model

TB-NAC, Base Series Model air conditioner thermostat, may be wired with or without connecting a common wire between the indoor equipment and the thermostat. However, it is recommended to use a common wire whenever possible. Without a common wire this thermostat becomes “power stealing.” This means it will need to steal a small amount of power from the equipment to which it is connected.

**NOTE:** Not all HVAC equipment is compatible with power stealing type thermostats. All Carrier equipment is directly compatible with this thermostat except the Thermostat Conversion Kit, Part #TSTATXXCNV10. For all non-Carrier equipment, consult the system equipment Installation Instructions before applying this thermostat in a power stealing manner.

#### Heat Pump Model

TB-NHP, Base Series Model heat pump thermostat, is compatible with all Carrier heat pump systems. It is NOT power stealing and MUST have both the R and C terminals connected to operate properly. This thermostat uses a green LED to indicate auxiliary heat and emergency heat operation.

### INSTALLATION

#### Step 1 — Thermostat Location

Thermostat should be mounted:

- Approximately 5 ft (1.5m) from floor.
- Close to or in a frequently used room, preferably on an inside partitioning wall.
- On a section of wall without pipes or duct work.

Thermostat should NOT be mounted:

- Close to a window, on an outside wall, or next to a door leading to the outside.
- Exposed to direct light and heat from the sun, a lamp, fireplace, or other heat-radiating object which may cause a false reading.
- Close to or in direct airflow from supply registers and return-air

grilles.

- In areas with poor air circulation, such as behind a door or in an alcove.

## Step 2 — Install Thermostat

### **WARNING**

#### **ELECTRICAL SHOCK HAZARD**

Failure to follow this warning could result in personal injury or death.

Before installing thermostat, turn off all power to unit. There may be more than 1 disconnect.

1. Turn OFF all power to unit.
2. If an existing thermostat is being replaced:
  - a. Remove existing thermostat from wall.
  - b. Disconnect wires from existing thermostat, one at a time. Be careful not to allow wires to fall back into wall.
  - c. As each wire is disconnected, record wire color and terminal marking.
  - d. Discard or recycle old thermostat.

### **CAUTION**

#### **ENVIRONMENTAL HAZARD**

Failure to follow this caution may result in environmental damage.

Mercury is a hazardous waste. Federal regulations require that Mercury be disposed of properly.

3. Separate front and back (mounting base) assembly of thermostat.
4. Route thermostat wires through hole in mounting base. Level mounting base against wall (for aesthetic value only, thermostat need not be level for proper operation) and mark wall through 2 mounting holes.
5. Drill two 3/16-in. mounting holes in wall where marked.
6. Secure mounting base to wall with 2 anchors and screws provided making sure all wires extend through hole in plastic.
7. Strip 1/4 in. insulation from thermostat wire and adjust length to reach terminal block connector on mounting base. Match and connect proper wiring in accordance with wiring diagrams.
8. Push any excess wire back into wall. Seal hole in wall to prevent air leaks. Leaks can affect thermostat operation. Any excess wire left inside thermostat casing may also affect thermostat operation by interfering with airflow across the temperature sensor.
9. Snap thermostat together making sure terminal block connector aligns, and assembly is secure.
10. Turn on power to unit.

On power up, depending on the thermostat model being used, the LCD readout will display either, AC or PC for air conditioner model (1-stage heat/1-stage cool), or HP or PH for heat pump model (2-stage heat/1-stage cool).

## Step 3 — Set Thermostat Configuration

Configuration options allow the installer to configure the thermostat for a particular installation. These selections are

intended to be made at installation and normally are not modified by the homeowner. Below is a list of available options followed by a description of each one.

- Option 01 - Equipment Type
- Option 03 - Fahrenheit or Centigrade operation
- Option 04 - Enable fan (G) ON with heat (W)
- Option 10 - O (reversing valve) On with Heat or Cool (present on Heat Pump model only)
- Option 13 - Room temperature offset adjustment

Note that not all configuration option numbers are used in this product.

#### **To Enter The Configuration Mode:**

Press and hold FAN button for approximately 10 sec until room temperature disappears and the display reads "01". You are now in configuration mode.

**NOTE:** If FAN button is pressed again, or if no button is pressed for 3 minutes, the thermostat will exit configuration mode and return to normal operation. To re-enter configuration mode, the FAN button must be pressed and held for 10 sec again.

While in the configuration mode, the temperature display is used to show both the option number and the selected choice within each option. Each press of the H/C button alternates between the option number and the selection within that option. When the configuration mode is first entered, option 01 is displayed. The up and down buttons now move between the available option numbers. Once an option number is selected, press the H/C button once to display the currently selected choice within that option. The up and down buttons now move between the available choices within that option. After the new choice is made, press the H/C button again to return to the option number display. When finished with option selections, press FAN button once to exit the configuration mode.

#### **Option 01 — Equipment Type**

Selections: with HP thermostat: HP, AC, PH, or PC  
with AC thermostat: AC or PC

Meanings:

PH or PC selects PTAC units (Packaged Terminal Air Conditioners) which are used in motel rooms and other rented spaces. When this option is selected, the display shows only the setpoint, not the room temperature. Also the compressor timeguard is disabled, allowing the compressor to turn on immediately when a demand is established.

HP or PH controls 1 speed heat pump with 1 stage of aux heat.

AC or PC controls 1 speed air conditioner with one stage of heat.

Note that this option allows a HP thermostat to be converted to control an AC system.

#### **Option 03 — Fahrenheit/Centigrade Selection**

This selection operates the thermostat in either Fahrenheit or Centigrade. Factory default is F.

**Available Selection:**

Use UP and DOWN buttons to change between F and C.

#### **Option 04 — G (fan) ON with W (Heat) Selection**

This selection determines whether G (fan) output is to be ON or OFF when W (furnace or strip heat) output is ON. Most furnaces and fan coils manage their own blowers and do not require a separate G signal. For these applications, select OFF. Some auxiliary heaters require a separate G signal from the thermostat to turn on the blower. In this case, select ON. Factory default is OFF (off).

**Available Selection:**

Use UP and DOWN buttons to change between ON and OFF.

**Option 10 — O (reversing valve) On with Heat or Cool Selection**

This selection is only available on heat pump model thermostats. This selection determines whether the reversing valve is energized in the heating or cooling mode. Factory default is C.

**Available Selection:**

Use UP and DOWN buttons to change between H and C.

**Option 13 — Room Temperature Offset Adjustment**

This option allows calibration (or deliberate miscalibration) of the room temperature sensor. There are various reasons why homeowners may want to have displayed temperature adjusted to a higher or lower value. The selected number is the number of degrees, plus or minus, which will be added to actual temperature.

The numbers can range between -5 and +5. Factory default is 0.

**Available Selection:**

Use UP and DOWN buttons to now move between -5 and +5 in increments of 1.

**Step 4 — Thermostat Operation****Temperature Display**

Thermostat will display room temperature until UP or DOWN button is pressed. The word SET appears when these buttons are pressed and the current setpoint is displayed. If no buttons are pressed for 5 sec, the display will change back to show room temperature.

**Timeguard Timer**

A 5-minute timeguard is built into the thermostat immediately upon power up, and any time the compressor turns off. The compressor will not turn on until the timeguard has expired. The timeguard affects only compressor operation. Pressing UP and FAN buttons simultaneously will override the timeguard for 1 cycle. With PH or PC selected under Option 01, this timer is defeated.

**Cycle Timer**

In normal heating and cooling operation the thermostat will not allow more than 4 equipment cycles per hour (or 1 cycle every 15 minutes). Both the Y and W outputs have a 15-minute timer that starts counting down when the output is turned on, (e.g., if Y output is turned on for 9 minutes and then satisfies, it cannot turn back on for another 6 minutes regardless of demand). However, pressing UP and FAN buttons simultaneously or changing the setpoint will override the timer for 1 cycle.

**Minimum on Timer**

Once the equipment has turned on, it will remain on for a minimum of 3 minutes regardless of demand. However, the

equipment can turn off in less than 3 minutes if a change in setpoint or a change in mode occurs.

**Staging Timer**

If the thermostat is a heat pump model, it has 2-stage heat capability. With HP operation, there is a 15-minute delay between the first and second stages of heat. The Y output will energize first, then 15 minutes later, W is allowed to come on if the thermostat determines it is not satisfying the demand.

However, if the heating demand is greater than 5°F, there will be only a 30 second delay before bringing on W.

**Auxiliary Heat Indicator**

A green LED indicates the use of auxiliary heat or emergency heat.

**Error Messages**

“--” (two dashes) will be displayed if the thermostat cannot properly read room temperature. If “--” appears, replace thermostat.

E4 will be displayed if the thermostat has an internal memory failure. If E4 appears, replace thermostat.

**Step 5 — Check Thermostat Operation****Fan Operation**

1. Press FAN button. This will start continuous fan operation. FAN annunciator will turn on.
2. Press FAN button again. This will stop continuous fan operation. FAN annunciator will turn off.

**Heating Operation**

1. Press H/C button until HEAT is displayed.
2. Press UP button until LCD readout reads 3°F above room temperature. Press UP and FAN buttons simultaneously to defeat timers. Heating system should begin to operate immediately.
3. For HP thermostats only, press H/C button until EMHT (emergency heat) appears. Press UP and FAN buttons simultaneously to defeat timers. Emergency heating (W is ON, Y is OFF) should begin immediately.

**Cooling Operation**

1. Press H/C button until COOL is displayed.
2. Press DOWN button until LCD readout reads 3°F below room temperature. Press UP and FAN buttons simultaneously to defeat timers. Cooling system should begin to operate immediately.

Table 1 shows the thermostat outputs for each available stage of heating or cooling. It may be useful in checkout or troubleshooting.

**Table 1 – Outputs**

EQUIPMENT CONFIGURATION OPTION #1	THERMOSTAT FACTORY CONFIGURATION	COOL STAGE 1	HEAT STAGE 1	HEAT STAGE 2	EM HEAT
AC, PC	AC, HP	Y, G	W	--	--
HP, PH RVS = C	HP	Y, G, O/B	Y, G	Y, G, W	W
HP, PH RVS = H	HP	Y, G	Y, G, O/B	Y, G, W, O/B	W

# WIRING DIAGRAMS

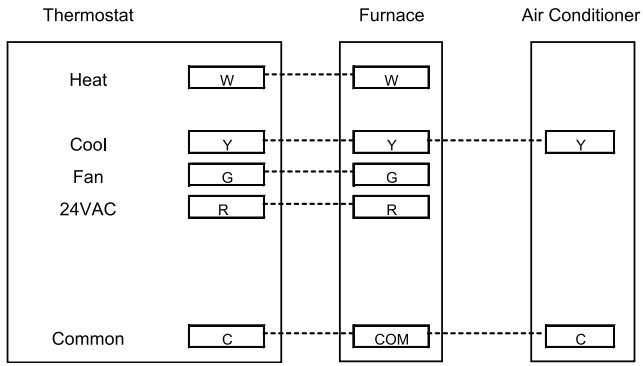

A06566

**Fig. 1 - A/C Thermostat Typical Installation**

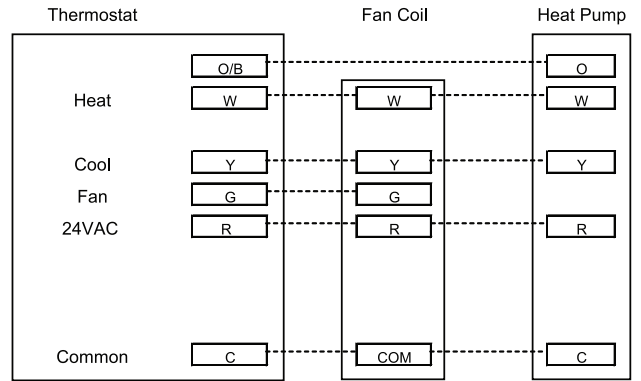

A06567

**Fig. 2 - HP Thermostat Typical Installation**

TB-NAC / TB-NHP

## Homeowner's Guide



A07108

Base Non-Programmable Thermostat

1. To Select the Mode:  
Use the H/C button to move between the choices. OFF, HEAT, COOL, or EMHT will appear on the display. EMHT will only appear on heat pump models.
2. To Select the Fan Operation:  
Use the FAN button to move between continuous fan (indicated by the FAN ON icon) and auto fan operation.
3. To Read the Room Temperature:  
The large display reads room temperature until a button is pressed.
4. To Adjust the Setpoint:  
In normal operation, the large display shows room temperature. At the first press of the UP or DOWN button, the large display shows the current setpoint and the SET TEMP icon is turned on. Further presses of the UP or DOWN button adjust the setpoint upward or downward. Five seconds after the last button press, the display returns to the room temperature and the SET TEMP icon turns off.

### TROUBLESHOOTING

#### What if there is a green light on in the upper corner of the display area?

This thermostat uses a green LED to indicate auxiliary heat and emergency heat operation on the Heat Pump model. This green light means one of two things.

1. Auxiliary Heat is on:  
This light turns on automatically when the system determines that it's too cold outside for your heat pump to heat the house without help. So, it's getting help from the electric heaters.

**NOTE:** This indicator does not reflect a problem with your system.

2. Emergency Heat is on:  
If the heat pump is not working properly, you can manually select the emergency heat for extra help in heating. You'll know there's a problem if the house can't seem to get warm when it's cold outside.  
You want to avoid using emergency heat, though, because it's the most expensive option. And, of course, if you suspect a problem with your heat pump, call your heating and cooling dealer immediately.



FOR SERVICE OR REPAIR, FOLLOW THESE STEPS IN ORDER:

**FIRST:** Contact the installer. You may find their name on the furnace or in your Homeowner's Packet. If the installer's name is not known, call your builder or home retailer if yours is a new residence.

**SECOND:** Contact the nearest distributor. (See telephone yellow pages.)

**THIRD:** Contact:

Carrier Corporation  
Consumer Relations  
P.O. Box 4808  
Syracuse, New York 13221  
Phone: 1-800-428-4326

Model No. \_\_\_\_\_ Unit Serial No. \_\_\_\_\_  
Date of Installation \_\_\_\_\_ Installed by \_\_\_\_\_  
Name of Owner \_\_\_\_\_ Address of Installation \_\_\_\_\_

**THERMOSTAT LIMITED WARRANTY**

FIVE-YEAR LIMITED WARRANTY - Carrier Corporation (hereinafter referred to as "Company") warrants this product to be free from defects in material and workmanship. If a defect is found within five years from date of original installation of product (whether or not actual use begins on that date) Company will provide a new or remanufactured part, at Company's sole option, to replace any defective part, without charge for the part itself.

This warranty does not include labor or other costs incurred for diagnosing, repairing, removing, installing, shipping, servicing or handling of either defective parts or replacement parts.

**WARRANTY CONDITIONS:**

- 3. Warranties apply only to products in their original installation location.
- 4. Installation, use, care, and maintenance must be normal and in accordance with instructions contained in the Owner's Manual and Company's service information.
- 5. Defective parts must be returned to the distributor through a registered servicing dealer for credit.
- 6. All work shall be performed during normal working hours.

**LIMITATIONS OF WARRANTIES - ALL IMPLIED WARRANTIES (INCLUDING IMPLIED WARRANTIES OF MERCHANTABILITY AND FITNESS FOR A PARTICULAR PURPOSE) ARE HEREBY LIMITED IN DURATION TO THE PERIOD FOR WHICH THE LIMITED WARRANTY IS GIVEN AND APPLIES. SOME STATES DO NOT ALLOW LIMITATIONS ON HOW LONG AN IMPLIED WARRANTY LASTS, SO THE ABOVE MAY NOT APPLY TO YOU. THE EXPRESSED WARRANTIES MADE IN THIS WARRANTY ARE EXCLUSIVE AND MAY NOT BE ALTERED, ENLARGED, OR CHANGED BY ANY DISTRIBUTOR, DEALER, OR OTHER PERSON, WHATSOEVER.**

**COMPANY WILL NOT BE RESPONSIBLE FOR:**

- 1. Normal maintenance as outlined in the installation and servicing instructions or Owner's Manual, including filter cleaning and/or replacement and lubrication.
- 2. Damage or repairs required as a consequence of faulty installation, misapplication, abuse, improper servicing, unauthorized alteration or improper operation.
- 3. Failure to start due to voltage conditions, blown fuses, open circuit breakers, or damages due to the inadequacy or interruption of electrical service.
- 4. Damage as a result of floods, winds, fires, lightning, accidents, corrosive environments or other conditions beyond the control of Company.
- 5. Parts not supplied or designated by Company, or damages resulting from their use.
- 6. Company products installed outside the continental U.S.A., Alaska, Hawaii, and Canada.
- 7. Electricity or fuel costs, or increases in electricity or fuel costs from any reason whatsoever, including additional or unusual use of supplemental electric heat.
- 8. **ANY SPECIAL INDIRECT OR CONSEQUENTIAL PROPERTY OR COMMERCIAL DAMAGE OF ANY NATURE WHATSOEVER.** Some states do not allow the exclusion of incidental or consequential damages, so the above limitation may not apply to you.

This Warranty gives you specific legal rights, and you may also have other rights which vary from state to state.

Catalog No. 03TS-TA50  
1-03

49004DP21